

FOR OFFICIAL USE



--	--	--	--	--	--

National  
Qualifications  
2023

Mark

--

**X807/76/01**

**Biology  
Paper 2**

THURSDAY, 27 APRIL

10:10 AM – 12:30 PM



\* X 8 0 7 7 6 0 1 \*

Fill in these boxes and read what is printed below.

Full name of centre

--

Town

--

Forename(s)

--

Surname

--

Number of seat

--

Date of birth

Day

--	--

Month

--	--

Year

--	--

Scottish candidate number

--	--	--	--	--	--	--	--	--	--

**Total marks — 95**

Attempt ALL questions.

**You may use a calculator.**

Questions 5 and 15 contain a choice.

Write your answers clearly in the spaces provided in this booklet. Additional space for answers and rough work is provided at the end of this booklet. If you use this space you must clearly identify the question number you are attempting. Any rough work must be written in this booklet. Score through your rough work when you have written your final copy.

Use **blue** or **black** ink.

Before leaving the examination room you must give this booklet to the Invigilator; if you do not, you may lose all the marks for this paper.



\* X 8 0 7 7 6 0 1 0 1 \*

Total marks — 95  
 Attempt ALL questions  
 Questions 5 and 15 contain a choice

1. At the start of DNA replication, the double helix unwinds and the strands separate as shown in the diagram.

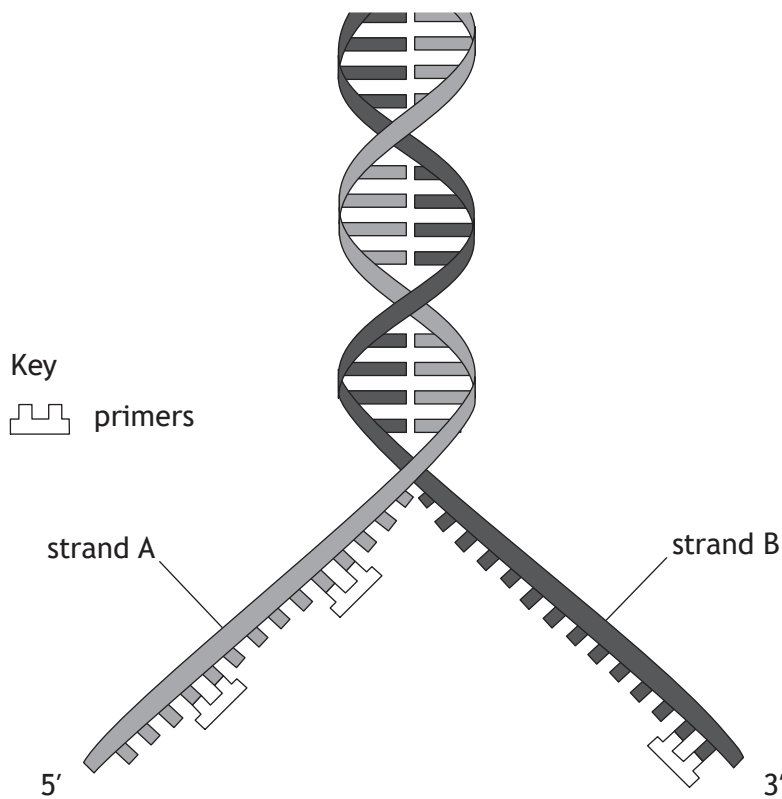

- (a) Name the enzyme that adds DNA nucleotides to newly synthesised strands. 1

\_\_\_\_\_

- (b) Strand A is the lagging strand.  
 Use information from the diagram to support this statement. 1

\_\_\_\_\_  
 \_\_\_\_\_



1. (continued)

(c) The polymerase chain reaction (PCR) is a technique carried out to amplify target sequences of DNA. It involves repeated cycles of heating and cooling.

Two different primers are used in each PCR procedure.

(i) Give a reason why two different primers are used.

1

\_\_\_\_\_

\_\_\_\_\_

(ii) State a temperature at which primers bind to the target sequence of DNA.

1

\_\_\_\_\_ °C

(d) One complete cycle of a PCR took 3 minutes.

Calculate how many copies of the DNA there would be after 9 minutes from an original sample of 30 DNA molecules.

1

*Space for calculation*

\_\_\_\_\_ copies

[Turn over



2. The doublesex gene in fruit flies determines whether they develop into males or females. The primary transcript of this gene can produce different mature transcripts as shown in the diagram.

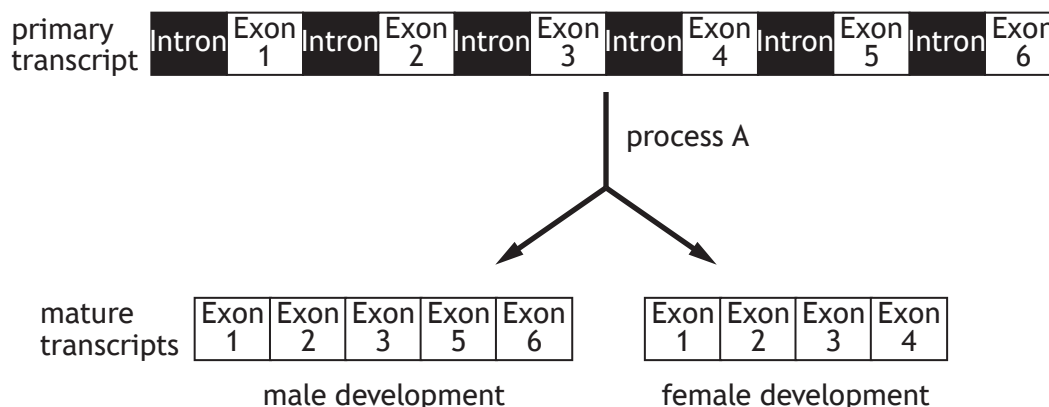

- (a) (i) Name process A.

1

---

- (ii) State why the mature transcript shown below could not be produced.

1

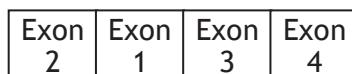

---



---

- (b) Splice site mutations can affect the development of fruit flies.

Describe the effect of a splice site mutation on a mature transcript and the effect on the protein synthesised.

2

Effect on mature transcript \_\_\_\_\_

---

Effect on protein \_\_\_\_\_

---



3. Stem cells are used in research to study how diseases develop.

(a) (i) State one other research use of stem cells.

1

---

---

(ii) Describe a property of embryonic stem cells, which makes them useful for research.

1

---

---

(iii) Suggest an ethical reason why medical research may involve the use of embryonic stem cells.

1

---

---

[Turn over



3. (continued)

- (b) When culturing stem cells, substances called cytokines can be included in the culture medium.

An investigation was carried out to determine the effect of cytokines on the growth of stem cells.

Cultures of stem cells were set up as shown.

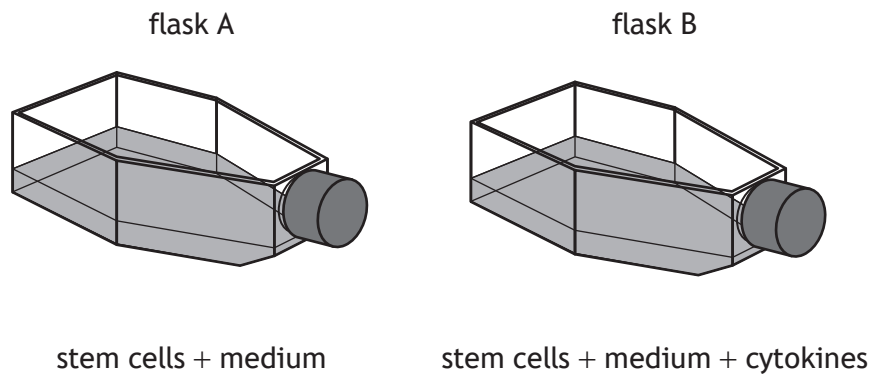

The cells were cultured for 10 days and the cell count was recorded every 2 days.

The results are shown in the table.

Day	Cell count (thousand cells per cm <sup>3</sup> )	
	Medium only	Medium + cytokines
2	22	36
4	50	130
6	330	760
8	520	1800
10	13	8200

- (i) Describe two differences in the cell count between the cultures.

2

1. \_\_\_\_\_  
 \_\_\_\_\_  
 \_\_\_\_\_

2. \_\_\_\_\_  
 \_\_\_\_\_  
 \_\_\_\_\_



3. (b) (continued)

- (ii) Calculate how many cells would be present in a  $0.01 \text{ cm}^3$  sample taken from the culture containing cytokines after 10 days.

1

*Space for calculation*

\_\_\_\_\_ thousand cells

- (iii) The cell count was a viable cell count.  
Use evidence from the table to support this statement.

1

---

---

[Turn over



4. The phylogenetic tree shows the evolutionary relatedness of several fish species.

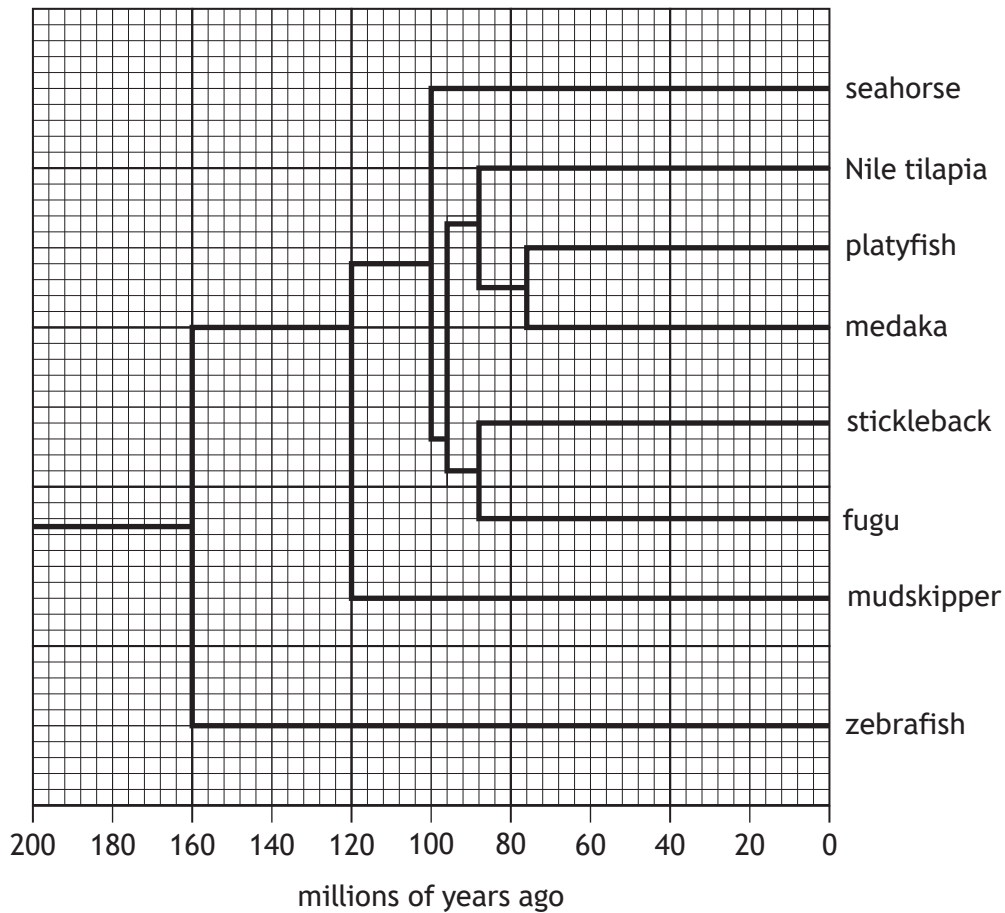

- (a) (i) State how many millions of years ago the last common ancestor of Nile tilapia and medaka existed. 1
- \_\_\_\_\_
- (ii) State how many species evolved from a common ancestor 100 million years ago. 1
- \_\_\_\_\_
- (iii) Name the species that is most distantly related to the mudskipper. 1
- \_\_\_\_\_



4. (continued)

- (b) Many fish species have fins on the underside of their bodies called pelvic fins. Nile tilapia, zebrafish and Atlantic cod have pelvic fins, but seahorses do not. A series of genes, A – F, is involved in fin development in fish. The genes present and their locations on a chromosome are shown in the diagram.

Nile tilapia	A	B	C	D	E	F
zebrafish	A	B	C	D	E	F
seahorse	A	B	D	E	F	
Atlantic cod	A	E	D	C	B	F

- (i) Use the information given to identify the gene responsible for the development of the pelvic fin. 1
- \_\_\_\_\_
- (ii) Name the type of mutation that resulted in the gene sequence found in the Atlantic cod. 1
- \_\_\_\_\_

[Turn over



5. Attempt either A or B. Write your answer in the space below.

A Write notes on the organisation and location of DNA in prokaryotic and eukaryotic cells.

5

OR

B Write notes on the translation stage of protein synthesis.

5

You may use labelled diagrams where appropriate.



6. Wild strains of yeast were grown in a fermenter to produce ethanol. Stages of the process occurring in the fermenter are shown in the diagram.



- (a) Name stage 1. 1

\_\_\_\_\_

- (b) There is a net gain of ATP in stage 1. 1  
 Explain why the ATP produced is described as a net gain.

\_\_\_\_\_  
 \_\_\_\_\_  
 \_\_\_\_\_

- (c) Name gas X produced in stage 2. 1

\_\_\_\_\_

- (d) High concentrations of ethanol kill wild strains of yeast. 1  
 In an attempt to increase ethanol tolerance in yeast, a wild strain was exposed to UV light.  
 Suggest why exposure to UV light may result in yeast cells that can survive in high concentrations of ethanol.

\_\_\_\_\_  
 \_\_\_\_\_

- (e) Fermentation can also occur in animal cells. 1  
 Name the product that pyruvate is converted to in animal cells.

\_\_\_\_\_

[Turn over



7. The Komodo dragon is a species of lizard.

An investigation was carried out into the effect of environmental temperature on the metabolic rate of a Komodo dragon.

The results are shown in the table.

Environmental temperature (°C)	Oxygen consumption (cm <sup>3</sup> /kg/hr)
20	0.4
25	0.7
30	1.1
35	1.4
40	1.7

- (a) The Komodo dragon is a conformer.

Use evidence from the table to support this statement.

1

---

---

- (b) Describe how the investigation could be improved to give more reliable results.

1

---

---

- (c) Calculate the average increase in oxygen consumption per °C between 20 °C and 40 °C.

1

*Space for calculation*

\_\_\_\_\_ cm<sup>3</sup>/kg/hr



\* X 8 0 7 7 6 0 1 1 2 \*

7. (continued)

- (d) Explain how increasing the environmental temperature leads to an increased metabolic rate in a Komodo dragon.

2

---

---

---

---

- (e) Name the type of response that allows conformers to tolerate variation in the environmental temperature.

1

---

- (f) Compare the range of ecological niches that can be occupied by conformers and regulators.

1

---

---

[Turn over



8. An investigation was carried out to find out how the breathing rate of a group of desert tortoises varied over a year.

The results are shown in the table.

Month	Average breathing rate (breaths/minute)
January	2.8
February	2.9
March	14.0
April	20.2
May	19.6
June	20.4
July	19.8
August	19.5
September	20.4
October	16.8
November	3.2
December	2.7

- (a) (i) Express, as a simple whole number ratio, the breathing rate in the months of January, March and October.

1

*Space for calculation*

\_\_\_\_\_ : \_\_\_\_\_ : \_\_\_\_\_  
 January                      March                      October



8. (a) (continued)

(ii) Use evidence from the table to identify the months when desert tortoises were hibernating.

1

\_\_\_\_\_

(b) If there is a drought, desert tortoises survive by decreasing their heart rate and breathing rate.

Name this response and explain why it is consequential.

2

Name \_\_\_\_\_

Explanation \_\_\_\_\_

\_\_\_\_\_

(c) Sugar gliders are small mammals that live in Australia. Their high metabolic rates are reduced each day.

(i) Give the term used for this type of behaviour.

1

\_\_\_\_\_

(ii) State the advantage to sugar gliders of reducing their metabolic rate each day.

1

\_\_\_\_\_

[Turn over



\* X 8 0 7 7 6 0 1 1 5 \*

9. An investigation was carried out to study the effect of intensity of exercise on metabolic rate.

**MARKS** DO NOT WRITE IN THIS MARGIN

A calorimeter was used to determine metabolic rate as shown in the diagram.

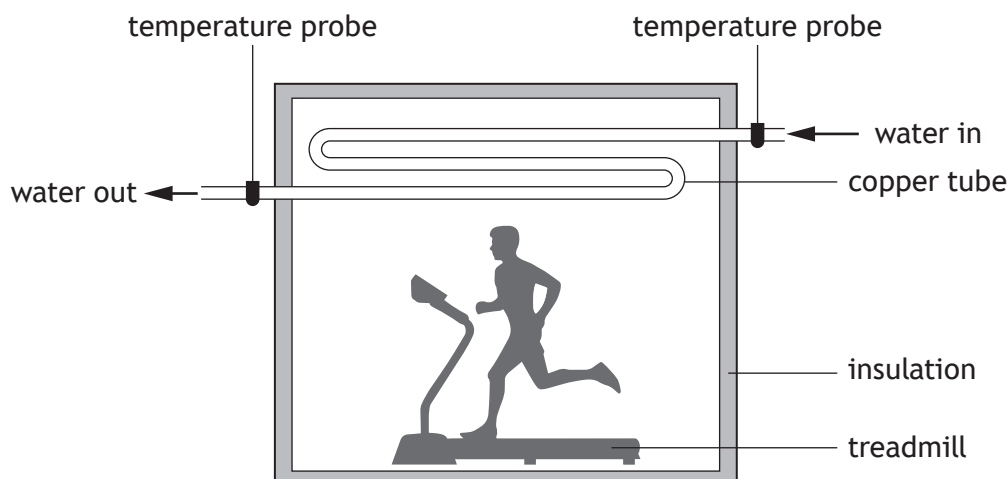

An individual walked on a treadmill in the calorimeter for 30 minutes and the temperature increase of the water was calculated every 5 minutes.

The procedure was repeated in another calorimeter with a different individual who ran on the treadmill.

The results are shown in the table.

Time (minutes)	Temperature increase of the water (°C)	
	Walking	Running
0	0	0
5	0.2	0.4
10	0.3	0.6
15	0.5	0.9
20	0.8	1.1
25	1.1	1.3
30	1.4	1.6

- (a) Explain how the design of the calorimeter allowed metabolic rate to be determined.

2

---



---



---

- (b) Name the independent variable in this investigation.

1

---



9. (continued)

(c) Identify two variables, not already mentioned, that should be controlled for a valid conclusion to be drawn.

2

1. \_\_\_\_\_

2. \_\_\_\_\_

(d) (i) On the grid, complete the line graph to show the results for **running**.  
(Additional graph paper, if required, can be found on *page 31.*)

2

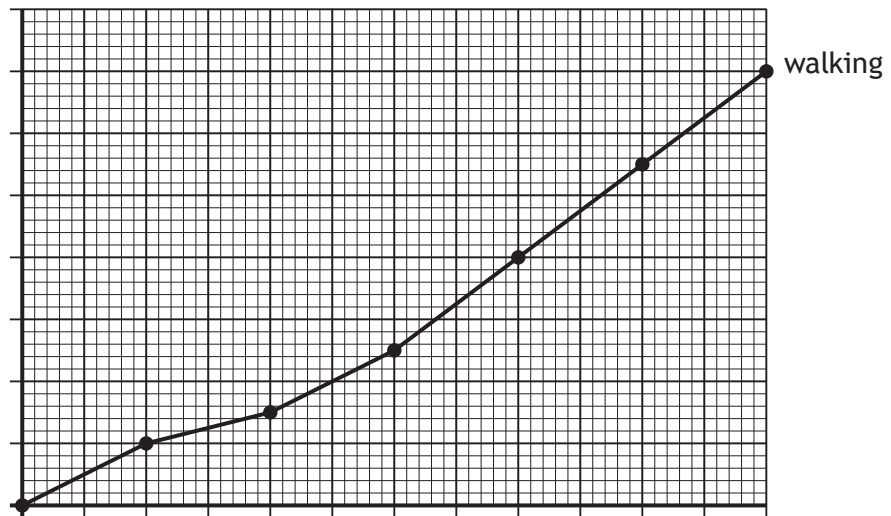

(ii) Predict the temperature increase after 35 minutes of walking on the treadmill.

1

\_\_\_\_\_ °C

(e) Draw a conclusion from the results of this investigation.

1

\_\_\_\_\_  
\_\_\_\_\_

[Turn over



10. Transferrin is a protein used to treat the blood disorder anaemia in humans.

Artificial chromosomes are used in recombinant DNA technology to genetically modify yeast cells to produce transferrin.

The strain of yeast cells used cannot synthesise the amino acid leucine, which is necessary for protein synthesis and growth of the yeast.

Some stages of this recombinant DNA technology process are shown in the diagram.

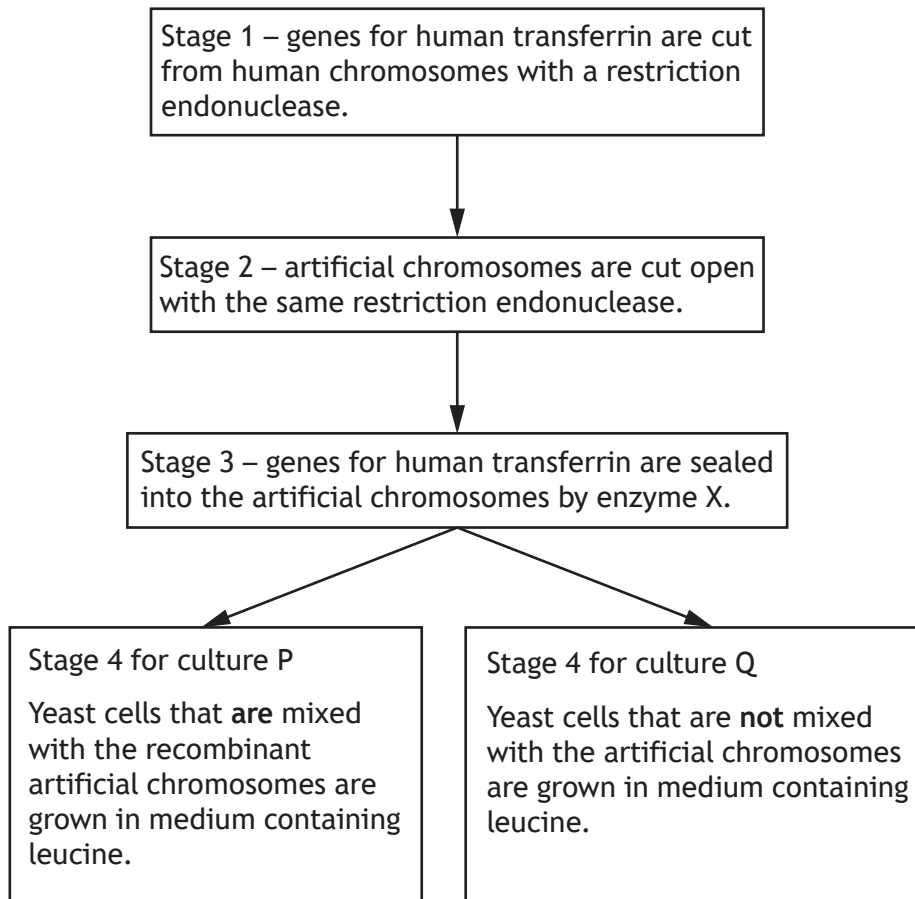

\* X 8 0 7 7 6 0 1 1 8 \*

10. (continued)

- (a) (i) State the term used to describe the artificial chromosome that carries the human gene into yeast cells.

1

\_\_\_\_\_

- (ii) State why an artificial chromosome rather than a plasmid may be used in recombinant DNA technology.

1

\_\_\_\_\_

- (b) Explain why the same restriction endonuclease is used in stages 1 and 2.

1

\_\_\_\_\_  
 \_\_\_\_\_  
 \_\_\_\_\_

- (c) Name enzyme X used in stage 3.

1

\_\_\_\_\_

- (d) The artificial chromosome used contains a selectable marker gene that only allows transformed yeast cells to synthesise leucine.

After stage 4, cultures P and Q were transferred to separate plates containing solid medium without leucine.

After incubation, yeast cells only grew on the plate containing culture P.

Explain this result.

2

\_\_\_\_\_  
 \_\_\_\_\_  
 \_\_\_\_\_  
 \_\_\_\_\_

[Turn over



11. Lettuce can be cultivated commercially in greenhouses.

The diagram represents some stages of the light reaction in photosynthesis in lettuce.

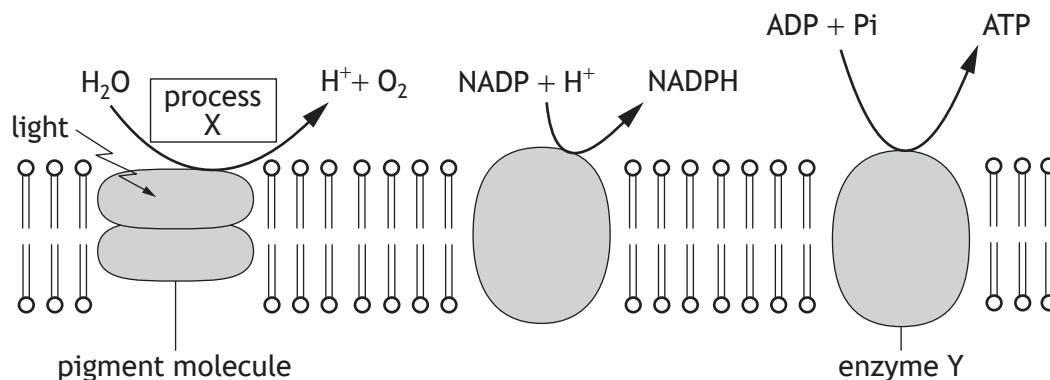

(a) Describe what happens to electrons in pigment molecules when light energy is absorbed.

1

\_\_\_\_\_

(b) Name process X and enzyme Y.

2

Process X \_\_\_\_\_

Enzyme Y \_\_\_\_\_



\* X 8 0 7 7 6 0 1 2 0 \*

11. (continued)

- (c) In an investigation, the light intensity within greenhouses was varied and the yield of lettuce was calculated at each light intensity.

The results are shown in the table.

Light intensity (units)	Yield of lettuce (g of dry mass per m <sup>2</sup> )
50	25
100	500
150	1250
175	1500
200	1500

- (i) Describe the relationship between light intensity and the yield of lettuce. 2

---



---

- (ii) Name an environmental factor, other than light intensity, which could increase the yield of lettuce produced.

Explain how this factor would affect the carbon fixation stage of photosynthesis. 2

Environmental factor \_\_\_\_\_

Explanation \_\_\_\_\_

---



---

[Turn over



12. In the 1960s in Scotland, large areas of natural habitat were cleared to make way for a new motorway. This resulted in habitat fragments with reduced species and genetic diversity.

(a) State the two components of species diversity.

2

1. \_\_\_\_\_

2. \_\_\_\_\_

(b) It was suggested that the decrease in genetic diversity was a result of the bottleneck effect.

Explain how the bottleneck effect may lead to the local extinction of certain species.

2

\_\_\_\_\_  
 \_\_\_\_\_  
 \_\_\_\_\_  
 \_\_\_\_\_

(c) In an attempt to increase biodiversity, habitat fragments were linked together using tunnels under the motorway.

(i) State the term used to describe these tunnels.

1

\_\_\_\_\_

(ii) Explain how these tunnels may result in an increase in biodiversity.

2

\_\_\_\_\_  
 \_\_\_\_\_  
 \_\_\_\_\_



13. The graph shows the area of land in the UK used to grow barley, and its yield between 1930 and 2000.

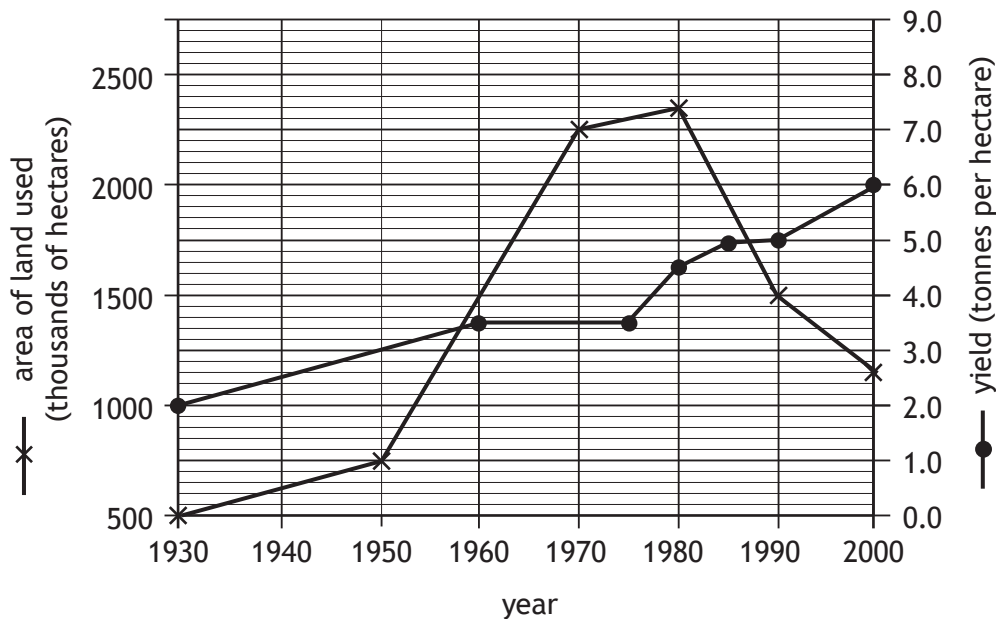

(a) Use values from the graph to describe the changes in the area of land used to grow barley from 1950 to 2000.

2

---



---



---



---

(b) State the barley yield when the area of land used was 750 thousand hectares.

1

\_\_\_\_\_ tonnes per hectare

[Turn over



13. (continued)

MARKS DO NOT WRITE IN THIS MARGIN

(c) Barley is used to feed livestock.

The table shows the mass of different types of livestock produced in the UK between 2000 and 2020.

Year	Mass of livestock produced in the UK ( $\times 10^6$ kg)		
	Cattle	Pigs	Poultry
2000	960	1293	1704
2010	1076	1354	1770
2020	1104	1380	2348

Calculate the percentage increase in the mass of cattle produced between 2000 and 2020.

1

Space for calculation

\_\_\_\_\_ %

(d) The feed conversion ratio for different types of livestock can be calculated using the following formula.

$$\text{Feed conversion ratio} = \frac{\text{mass of food eaten by livestock}}{\text{mass of livestock produced}}$$

The bar chart shows the feed conversion ratio of different types of livestock.

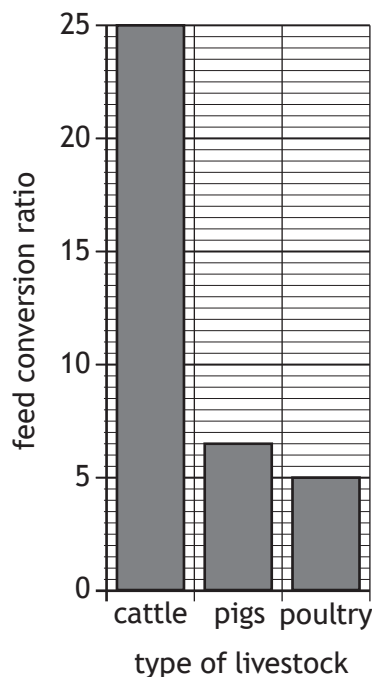

13. (d) (continued)

Use information in the table and bar chart to calculate the total mass of feed required for poultry production in the UK in 2020.

*Space for calculation*

1

\_\_\_\_\_ × 10<sup>6</sup> kg

(e) Using information in the bar chart explain why eating poultry or pigs reduces the impact on food security compared with eating cattle.

2

---

---

---

---

[Turn over



\* X 8 0 7 7 6 0 1 2 5 \*

14. Dodder is a plant that grows up blueberry bushes using root-like structures to remove sugar and other nutrients from the stems of the blueberry bushes.



blueberry stem

dodder

- (a) The relationship between the dodder plant and the blueberry bush is symbiotic.

- (i) Identify this type of symbiosis.

1

\_\_\_\_\_

- (ii) Justify your answer.

2

\_\_\_\_\_  
 \_\_\_\_\_  
 \_\_\_\_\_



14. (continued)

- (b) An investigation was carried out into the effect of dodder on blueberry yield. Blueberries from two fields, one of which was infected with dodder, were harvested and yields recorded.

The results are shown in the table.

Treatment	Average blueberry yield (kg per hectare)
Infected	18 000
Uninfected	22 500

Each field had an area of 6.7 hectares.

- (i) Calculate the reduction in blueberry yield due to the dodder infection. 1

*Space for calculation*

\_\_\_\_\_ kg

- (ii) Explain why the uninfected field is included as a control in this investigation. 1

\_\_\_\_\_

\_\_\_\_\_

- (iii) It was suggested that each large field could have been separated into many small plots and the treatments randomised.

State why this would be considered as good experimental design. 1

\_\_\_\_\_

[Turn over



\* X 8 0 7 7 6 0 1 2 7 \*

15. Attempt either A or B. Write your answer in the space below and on pages 29 and 30.

A Write notes on plant and animal breeding under the following headings:

(i) inbreeding

3

(ii) crossbreeding.

6

OR

B Write notes on social behaviour under the following headings:

(i) altruism

4

(ii) primate behaviour.

5

You may use labelled diagrams where appropriate.



\* X 8 0 7 7 6 0 1 2 8 \*

MARKS DO NOT  
WRITE IN  
THIS  
MARGIN

ADDITIONAL SPACE FOR ANSWER to question 15



MARKS DO NOT  
WRITE IN  
THIS  
MARGIN

ADDITIONAL SPACE FOR ANSWER to question 15

[END OF QUESTION PAPER]



\* X 8 0 7 7 6 0 1 3 0 \*

ADDITIONAL SPACE FOR ANSWERS AND ROUGH WORK

Additional graph paper for question 9 (d) (i)

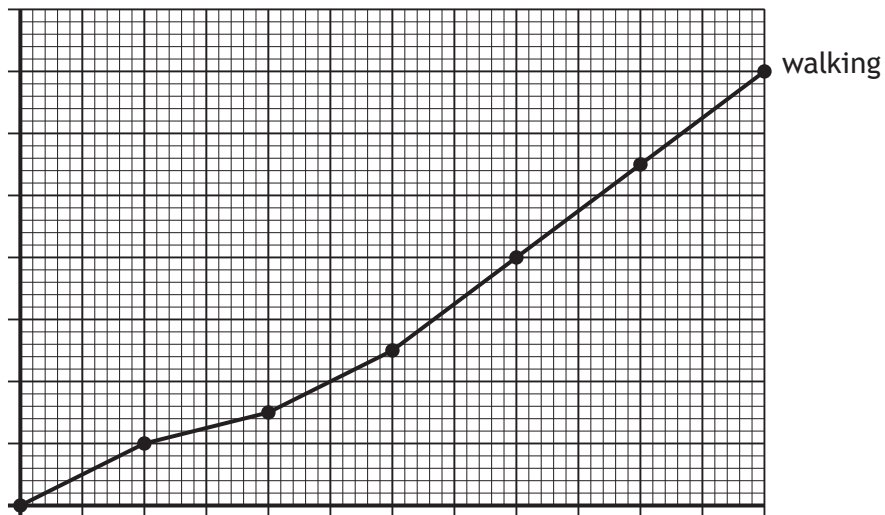

MARKS DO NOT  
WRITE IN  
THIS  
MARGIN

ADDITIONAL SPACE FOR ANSWERS AND ROUGH WORK



\* X 8 0 7 7 6 0 1 3 2 \*

MARKS DO NOT  
WRITE IN  
THIS  
MARGIN

ADDITIONAL SPACE FOR ANSWERS AND ROUGH WORK



\* X 8 0 7 7 6 0 1 3 3 \*

[BLANK PAGE]

DO NOT WRITE ON THIS PAGE



\* X 8 0 7 7 6 0 1 3 4 \*

[BLANK PAGE]

DO NOT WRITE ON THIS PAGE



\* X 8 0 7 7 6 0 1 3 5 \*

[BLANK PAGE]

DO NOT WRITE ON THIS PAGE

*Acknowledgement of copyright*

Question 14      Eifel-Details/shutterstock.com

