



National
Qualifications
2015

X713/76/02

**Chemistry
Section 1 — Questions**

THURSDAY, 28 MAY

1:00 PM – 3:30 PM

Instructions for the completion of Section 1 are given on *Page two* of your question and answer booklet X713/76/01.

Record your answers on the answer grid on *Page three* of your question and answer booklet.

Reference may be made to the Chemistry Higher and Advanced Higher Data Booklet.

Before leaving the examination room you must give your question and answer booklet to the Invigilator; if you do not you may lose all the marks for this paper.



* X 7 1 3 7 6 0 2 *

SECTION 1 — 20 marks

Attempt ALL questions

1. The elements nitrogen, oxygen, fluorine and neon
- A can form negative ions
 - B are made up of diatomic molecules
 - C have single bonds between the atoms
 - D are gases at room temperature.
2. Which of the following equations represents the first ionisation energy of fluorine?
- A $\text{F}^-(\text{g}) \rightarrow \text{F}(\text{g}) + \text{e}^-$
 - B $\text{F}^-(\text{g}) \rightarrow \frac{1}{2}\text{F}_2(\text{g}) + \text{e}^-$
 - C $\text{F}(\text{g}) \rightarrow \text{F}^+(\text{g}) + \text{e}^-$
 - D $\frac{1}{2}\text{F}_2(\text{g}) \rightarrow \text{F}^+(\text{g}) + \text{e}^-$
3. Which of the following atoms has least attraction for bonding electrons?
- A Carbon
 - B Nitrogen
 - C Phosphorus
 - D Silicon
4. Which of the following is **not** an example of a van der Waals' force?
- A Covalent bond
 - B Hydrogen bond
 - C London dispersion force
 - D Permanent dipole - permanent dipole attraction

5. Which of the following has more than one type of van der Waals' force operating between its molecules in the liquid state?

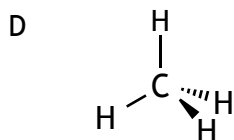
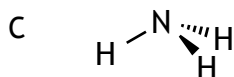
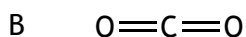

6. Oil molecules are more likely to react with oxygen in the air than fat molecules. During the reaction the oil molecules

- A are reduced
- B become rancid
- C are hydrolysed
- D become unsaturated.

7. Which of the following mixtures will form when $\text{NaOH}(\text{aq})$ is added to a mixture of propanol and ethanoic acid?

- A Propanol and sodium ethanoate
- B Ethanoic acid and sodium propanoate
- C Sodium hydroxide and propyl ethanoate
- D Sodium hydroxide and ethyl propanoate

8. Oils contain carbon to carbon double bonds which can undergo addition reactions with iodine.

The iodine number of an oil is the mass of iodine in grams that will react with 100 g of oil.

Which line in the table shows the oil that is likely to have the lowest melting point?

	<i>Oil</i>	<i>Iodine number</i>
A	Corn	123
B	Linseed	179
C	Olive	81
D	Soya	130

9. When an oil is hydrolysed, which of the following molecules is always produced?

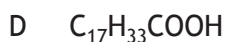
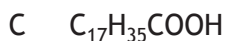
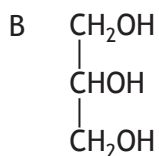
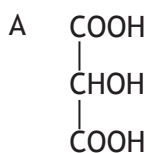

10. Enzymes are involved in the browning of cut fruit.

One reaction taking place is:

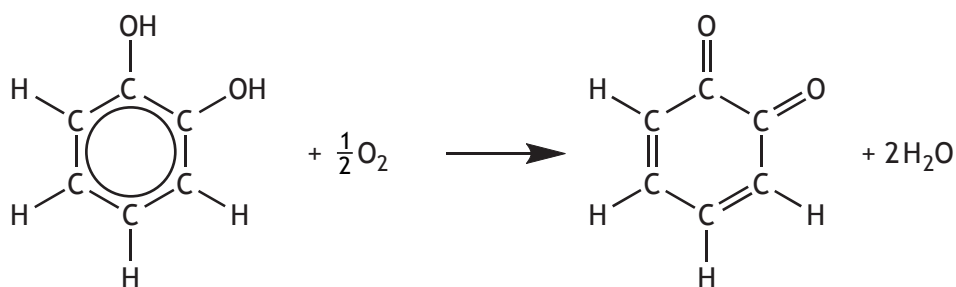

Which of the following correctly describes the above reaction?

- A Oxidation
- B Reduction
- C Hydrolysis
- D Condensation

11. Which of the following statements is correct for ketones?

A They are formed by oxidation of tertiary alcohols.

B They contain the group $\begin{array}{c} \text{O} \\ // \\ \text{---C} \\ \backslash \\ \text{H} \end{array}$.

C They contain a carboxyl group.

D They will not react with Fehling's solution.

12. Carvone is a natural product that can be extracted from orange peel.

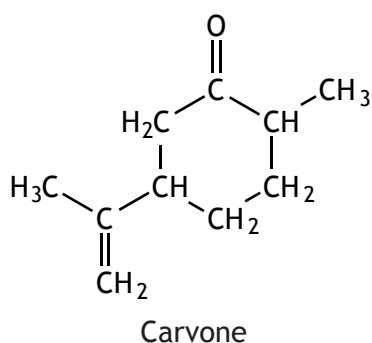

Which line in the table correctly describes the reaction of carvone with bromine solution and with acidified potassium dichromate solution?

	<i>Reaction with bromine solution</i>	<i>Reaction with acidified potassium dichromate solution</i>
A	no reaction	no reaction
B	no reaction	orange to green
C	decolourises	orange to green
D	decolourises	no reaction

13. The structure of isoprene is

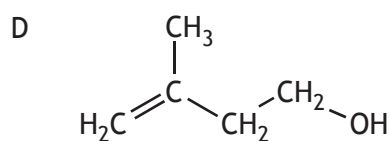
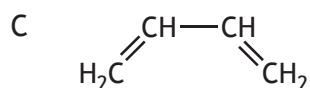
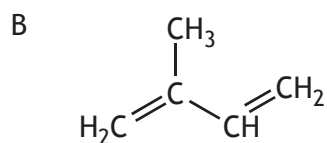
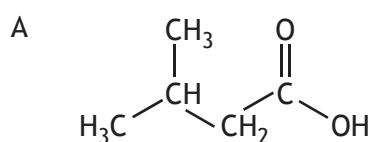

[Turn over

14. The antibiotic, erythromycin, has the following structure.

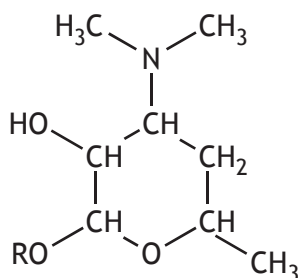

To remove its bitter taste, the erythromycin is reacted to give the compound with the structure shown below.

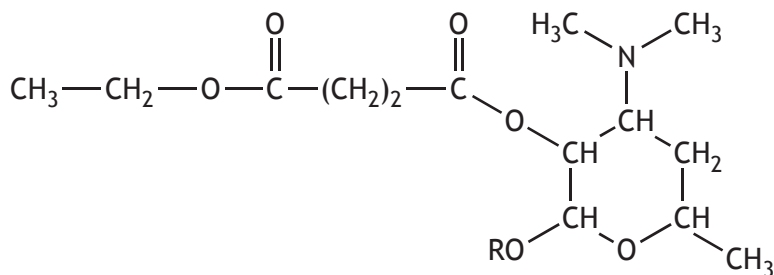

Which of the following types of compound has been reacted with erythromycin to produce this compound?

- A Alcohol
- B Aldehyde
- C Carboxylic acid
- D Ketone

15. Which of the following is an isomer of 2,2-dimethylpentan-1-ol?

- A $\text{CH}_3\text{CH}_2\text{CH}_2\text{CH}(\text{CH}_3)\text{CH}_2\text{OH}$
- B $(\text{CH}_3)_3\text{CCH}(\text{CH}_3)\text{CH}_2\text{OH}$
- C $\text{CH}_3\text{CH}_2\text{CH}_2\text{CH}_2\text{CH}_2\text{CH}_2\text{CH}_2\text{CH}_2\text{OH}$
- D $(\text{CH}_3)_2\text{CHC}(\text{CH}_3)_2\text{CH}_2\text{CH}_2\text{OH}$

16. Consider the reaction pathway shown below.

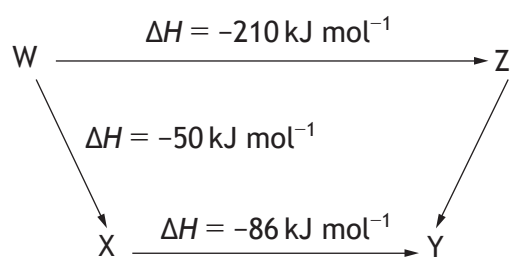

According to Hess's Law, the ΔH value, in kJ mol^{-1} , for reaction Z to Y is

- A +74
- B -74
- C +346
- D -346.

[Turn over

17. $I_2(s) \rightarrow I_2(g) \quad \Delta H = +60 \text{ kJ mol}^{-1}$
 $I_2(g) \rightarrow 2I(g) \quad \Delta H = +243 \text{ kJ mol}^{-1}$
 $I(g) + e^- \rightarrow I^-(g) \quad \Delta H = -349 \text{ kJ mol}^{-1}$

Which of the following would show the energy diagram for $I_2(s) + 2e^- \rightarrow 2I^-(g)$?

A

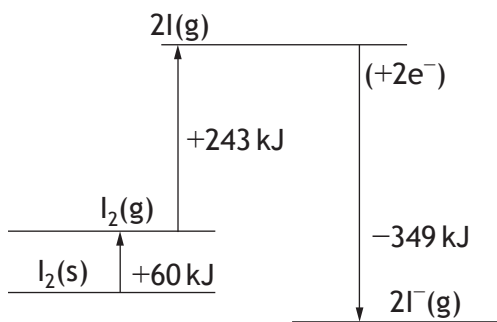

B

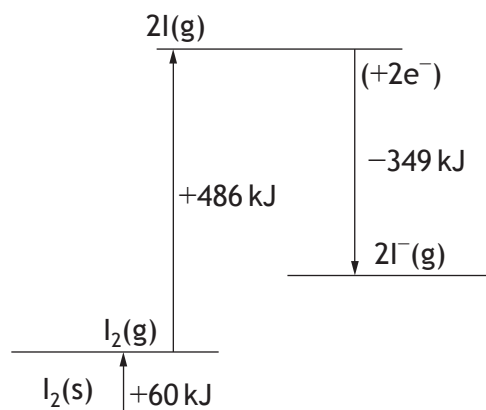

C

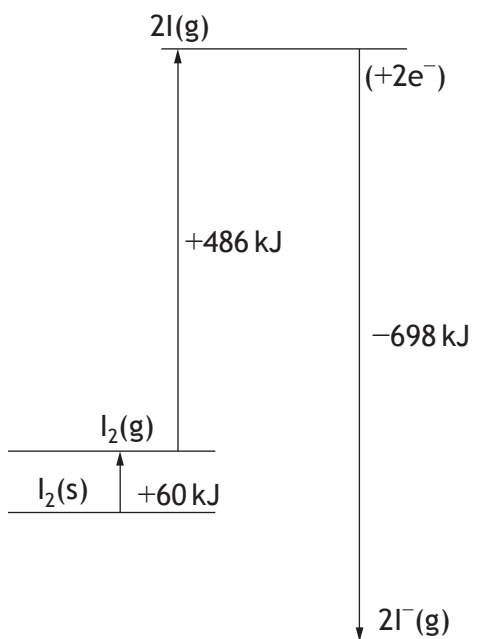

D

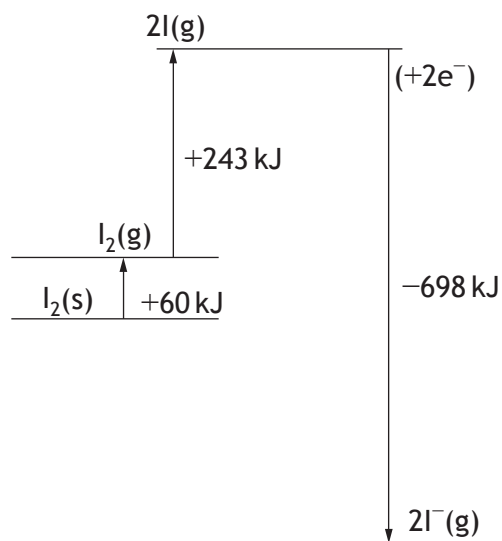

18. Which of the following statements regarding a chemical reaction at equilibrium is always correct?

- A The rates of the forward and reverse reactions are equal.
- B The concentration of reactants and products are equal.
- C The forward and reverse reactions have stopped.
- D The addition of a catalyst changes the position of the equilibrium.

19. A reaction has the following potential energy diagram.

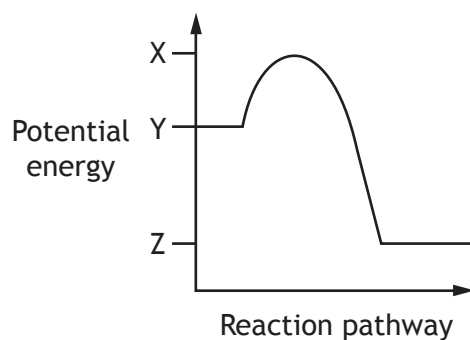

The activation energy for the forward reaction is

- A $X - Y$
 - B $Y - X$
 - C $Y - Z$
 - D $Z - Y$.
20. Which of the following will react with Br_2 but **not** with I_2 ?
- A OH^-
 - B SO_3^{2-}
 - C Fe^{2+}
 - D Mn^{2+}

[END OF SECTION 1. NOW ATTEMPT THE QUESTIONS IN SECTION 2
OF YOUR QUESTION AND ANSWER BOOKLET.]

[BLANK PAGE]

DO NOT WRITE ON THIS PAGE

[BLANK PAGE]

DO NOT WRITE ON THIS PAGE

[BLANK PAGE]

DO NOT WRITE ON THIS PAGE

FOR OFFICIAL USE



National
Qualifications
2015

Mark

X713/76/01

**Chemistry
Section 1 — Answer Grid
and Section 2**

THURSDAY, 28 MAY

1:00 PM – 3:30 PM



* X 7 1 3 7 6 0 1 *

Fill in these boxes and read what is printed below.

Full name of centre

Town

Forename(s)

Surname

Number of seat

Date of birth

Day

Month

Year

Scottish candidate number

Total marks — 100

SECTION 1 — 20 marks

Attempt ALL questions.

Instructions for completion of Section 1 are given on *Page two*.

SECTION 2 — 80 marks

Attempt ALL questions

Reference may be made to the Chemistry Higher and Advanced Higher Data Booklet.

Write your answers clearly in the spaces provided in this booklet. Additional space for answers and rough work is provided at the end of this booklet. If you use this space you must clearly identify the question number you are attempting. Any rough work must be written in this booklet. You should score through your rough work when you have written your final copy.

Use **blue** or **black** ink.

Before leaving the examination room you must give this booklet to the Invigilator; if you do not you may lose all the marks for this paper.



* X 7 1 3 7 6 0 1 0 1 *

The questions for Section 1 are contained in the question paper X713/76/02.
Read these and record your answers on the answer grid on *Page three* opposite.
Use **blue** or **black** ink. Do NOT use gel pens or pencil.

1. The answer to each question is **either** A, B, C or D. Decide what your answer is, then fill in the appropriate bubble (see sample question below).
2. There is **only one correct** answer to each question.
3. Any rough working should be done on the additional space for answers and rough work at the end of this booklet.

Sample Question

To show that the ink in a ball-pen consists of a mixture of dyes, the method of separation would be:

- A fractional distillation
- B chromatography
- C fractional crystallisation
- D filtration.

The correct answer is **B**—chromatography. The answer **B** bubble has been clearly filled in (see below).

A	B	C	D
<input type="radio"/>	<input checked="" type="radio"/>	<input type="radio"/>	<input type="radio"/>

Changing an answer

If you decide to change your answer, cancel your first answer by putting a cross through it (see below) and fill in the answer you want. The answer below has been changed to **D**.

A	B	C	D
<input type="radio"/>	<input checked="" type="radio"/>	<input type="radio"/>	<input checked="" type="radio"/>

If you then decide to change back to an answer you have already scored out, put a tick (✓) to the **right** of the answer you want, as shown below:

A	B	C	D	or	A	B	C	D
<input type="radio"/>	<input checked="" type="radio"/>	<input type="radio"/>	<input checked="" type="radio"/>		<input type="radio"/>	<input checked="" type="radio"/>	<input type="radio"/>	<input type="radio"/>



SECTION 1 — Answer Grid



	A	B	C	D
1	<input type="radio"/>	<input type="radio"/>	<input type="radio"/>	<input type="radio"/>
2	<input type="radio"/>	<input type="radio"/>	<input type="radio"/>	<input type="radio"/>
3	<input type="radio"/>	<input type="radio"/>	<input type="radio"/>	<input type="radio"/>
4	<input type="radio"/>	<input type="radio"/>	<input type="radio"/>	<input type="radio"/>
5	<input type="radio"/>	<input type="radio"/>	<input type="radio"/>	<input type="radio"/>
6	<input type="radio"/>	<input type="radio"/>	<input type="radio"/>	<input type="radio"/>
7	<input type="radio"/>	<input type="radio"/>	<input type="radio"/>	<input type="radio"/>
8	<input type="radio"/>	<input type="radio"/>	<input type="radio"/>	<input type="radio"/>
9	<input type="radio"/>	<input type="radio"/>	<input type="radio"/>	<input type="radio"/>
10	<input type="radio"/>	<input type="radio"/>	<input type="radio"/>	<input type="radio"/>
11	<input type="radio"/>	<input type="radio"/>	<input type="radio"/>	<input type="radio"/>
12	<input type="radio"/>	<input type="radio"/>	<input type="radio"/>	<input type="radio"/>
13	<input type="radio"/>	<input type="radio"/>	<input type="radio"/>	<input type="radio"/>
14	<input type="radio"/>	<input type="radio"/>	<input type="radio"/>	<input type="radio"/>
15	<input type="radio"/>	<input type="radio"/>	<input type="radio"/>	<input type="radio"/>
16	<input type="radio"/>	<input type="radio"/>	<input type="radio"/>	<input type="radio"/>
17	<input type="radio"/>	<input type="radio"/>	<input type="radio"/>	<input type="radio"/>
18	<input type="radio"/>	<input type="radio"/>	<input type="radio"/>	<input type="radio"/>
19	<input type="radio"/>	<input type="radio"/>	<input type="radio"/>	<input type="radio"/>
20	<input type="radio"/>	<input type="radio"/>	<input type="radio"/>	<input type="radio"/>



[BLANK PAGE]

DO NOT WRITE ON THIS PAGE



* X 7 1 3 7 6 0 1 0 4 *

[Turn over for Question 1 on *Page six*

DO NOT WRITE ON THIS PAGE



* X 7 1 3 7 6 0 1 0 5 *

SECTION 2 — 80 marks

Attempt ALL questions

1. Volcanoes produce a variety of molten substances, including sulfur and silicon dioxide.

(a) Complete the table to show the strongest type of attraction that is broken when each substance melts.

<i>Substance</i>	<i>Melting point (°C)</i>	<i>Strongest type of attraction broken when substance melts</i>
sulfur	113	
silicon dioxide	1610	

2

(b) Volcanic sulfur can be put to a variety of uses. One such use involves reacting sulfur with phosphorus to make a compound with formula P_4S_3 .

(i) Draw a possible structure for P_4S_3 .

1

(ii) Explain why the covalent radius of sulfur is smaller than that of phosphorus.

1



* X 7 1 3 7 6 0 1 0 6 *

MARKS DO NOT WRITE IN THIS MARGIN

1. (b) (continued)

- (iii) The melting point of sulfur is much higher than that of phosphorus.

Explain fully, in terms of the structures of sulfur and phosphorus molecules and the intermolecular forces between molecules of each element, why the melting point of sulfur is much higher than that of phosphorus.

3

[Turn over



* X 7 1 3 7 6 0 1 0 7 *

2. (a) A student investigated the effect of changing acid concentration on reaction rate. Identical strips of magnesium ribbon were dropped into different concentrations of excess hydrochloric acid and the time taken for the magnesium to completely react recorded.

A graph of the student's results is shown below.

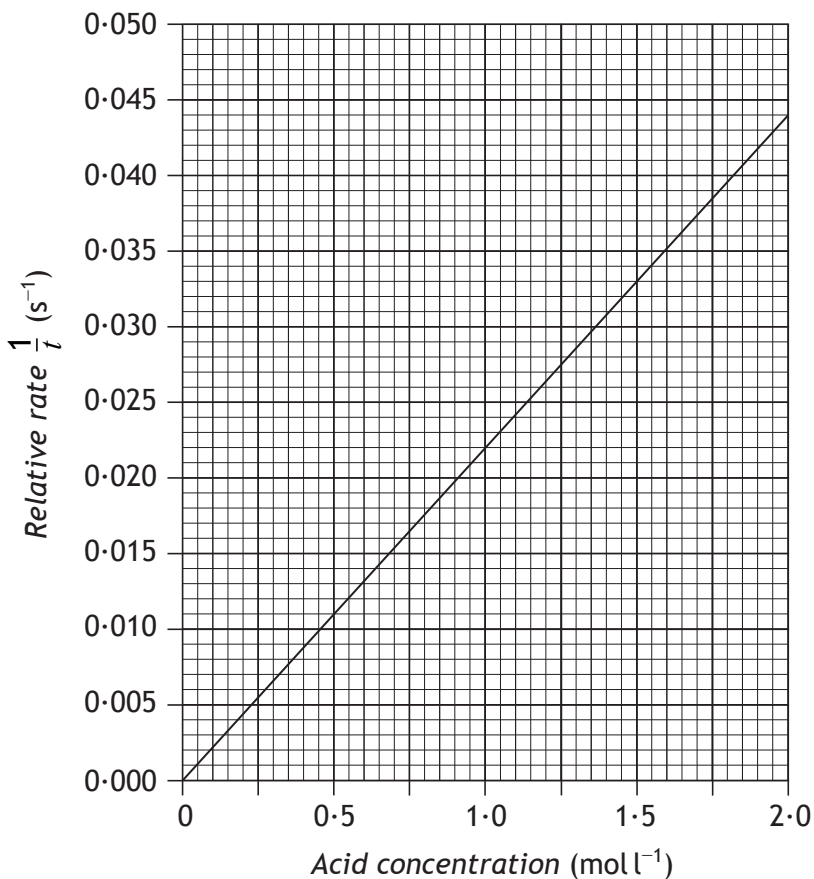

Use information from the graph to calculate the reaction time, in seconds, when the concentration of the acid was 1.0 mol l⁻¹.

1



2. (continued)

(b) The rate of reaction can also be altered by changing the temperature or using a catalyst.

(i) Graph 1 shows the distribution of kinetic energies of molecules in a gas at 100 °C.

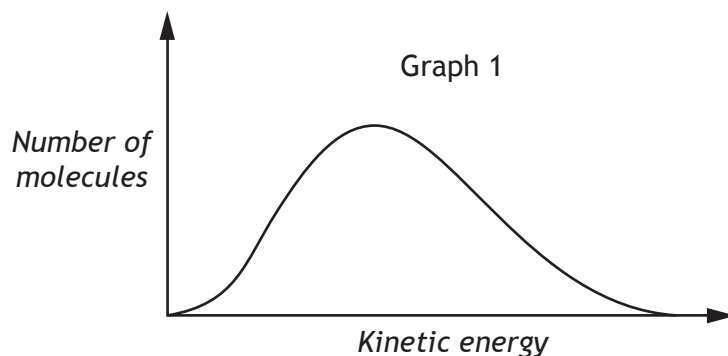

Add a second curve to graph 1 to show the distribution of kinetic energies at 50 °C.

1

(ii) In graph 2, the shaded area represents the number of molecules with the required activation energy, E_a .

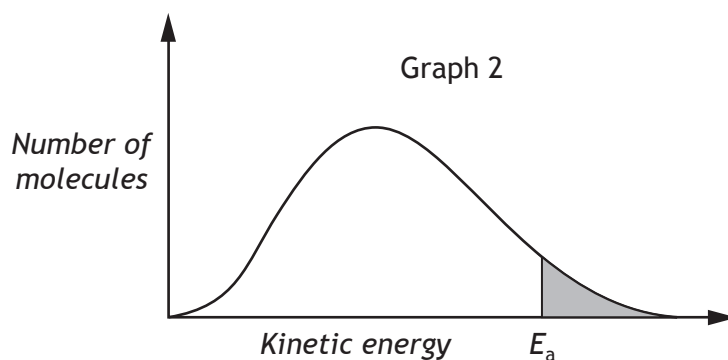

Draw a line to show how a catalyst affects the activation energy.

1

[Turn over



* X 7 1 3 7 6 0 1 0 9 *

3. (a) Methyl cinnamate is an ester used to add strawberry flavour to foods. It is a naturally occurring ester found in the essential oil extracted from the leaves of strawberry gum trees.

To extract the essential oil, steam is passed through shredded strawberry gum leaves. The steam and essential oil are then condensed and collected.

- (i) Complete the diagram to show an apparatus suitable for carrying out this extraction.

(An additional diagram, if required, can be found on *Page thirty-seven*).

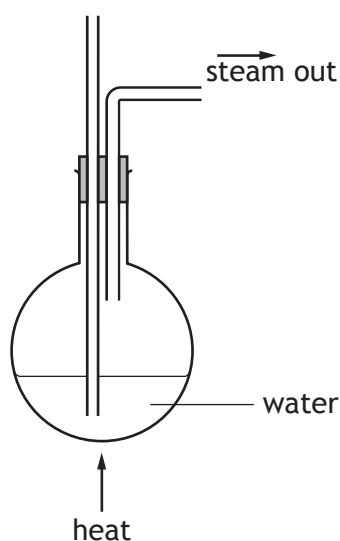

- (ii) The essential oil extracted is a mixture of compounds.

Suggest a technique that could be used to separate the mixture into pure compounds.

- (b) A student prepared a sample of methyl cinnamate from cinnamic acid and methanol.

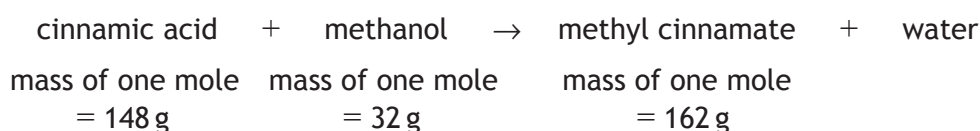

6.5 g of cinnamic acid was reacted with 2.0 g of methanol.



3. (b) (continued)

(i) Show, by calculation, that cinnamic acid is the limiting reactant.
(One mole of cinnamic acid reacts with one mole of methanol.) 2

(ii) (A) The student obtained 3.7g of methyl cinnamate from 6.5g of cinnamic acid.
Calculate the percentage yield. 2

(B) The student wanted to scale up the experiment to make 100g of methyl cinnamate.
Cinnamic acid costs £35.00 per 250g.
Calculate the cost of cinnamic acid needed to produce 100g of methyl cinnamate. 2

[Turn over



4. Up to 10% of perfumes sold in the UK are counterfeit versions of brand name perfumes.

One way to identify if a perfume is counterfeit is to use gas chromatography. Shown below are gas chromatograms from a brand name perfume and two different counterfeit perfumes. Some of the peaks in the brand name perfume have been identified as belonging to particular compounds.

DO NOT
WRITE IN
THIS
MARGIN

Brand name perfume

- (A) linalool
- (B) citronellol
- (C) geraniol
- (D) eugenol
- (E) anisyl alcohol
- (F) coumarin
- (G) benzyl salicylate

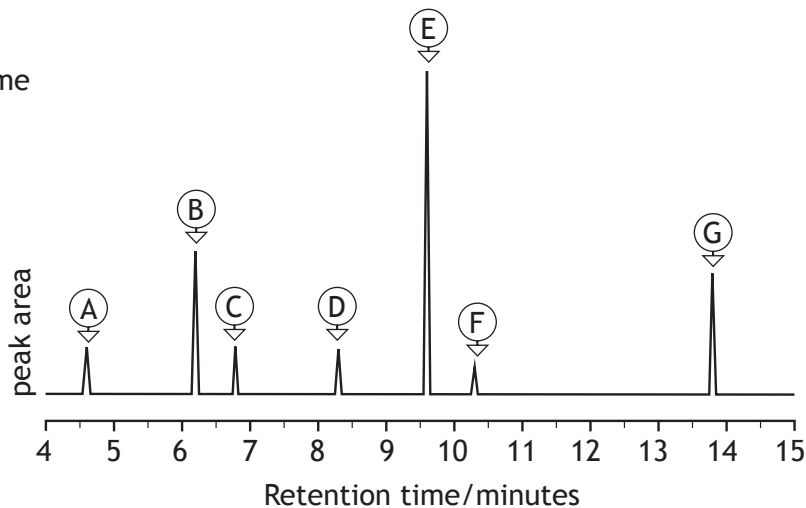

Counterfeit A

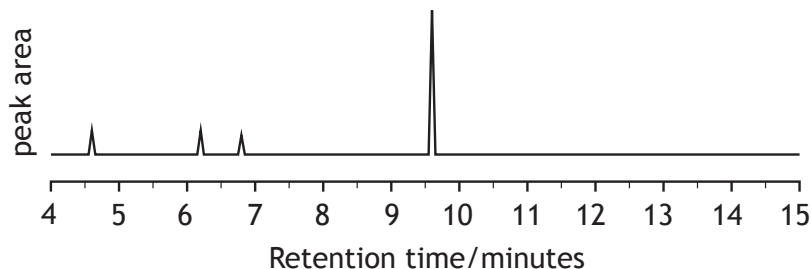

Counterfeit B

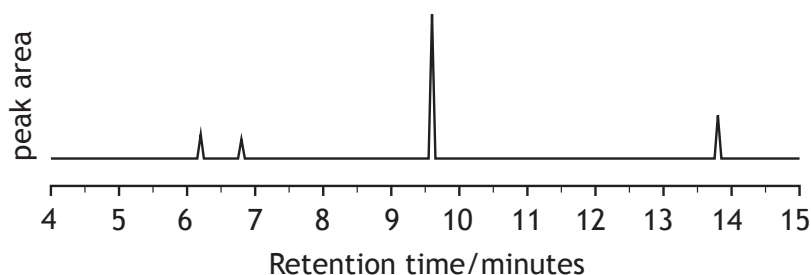

* X 7 1 3 7 6 0 1 1 2 *

4. (continued)

- | | |
|---|---|
| (a) Identify one compound present in the brand name perfume that appears in both counterfeit perfumes. | 1 |
| (b) Some compounds in the brand name perfume are not found in the counterfeit perfumes. State another difference that the chromatograms show between the counterfeit perfumes and the brand name perfume. | 1 |
| (c) The gas used to carry the perfume sample along the chromatography column is helium. | |
| (i) Suggest why helium is used. | 1 |
| (ii) Apart from the polarity of the molecules, state another factor that would affect the retention time of molecules during gas chromatography. | 1 |



4. (continued)

(d) Many of the compounds in perfumes are molecules consisting of joined isoprene units.

(i) State the name that is given to molecules consisting of joined isoprene units.

1

(ii) Geraniol is one of the compounds found in perfume. It has the following structural formula and systematic name.

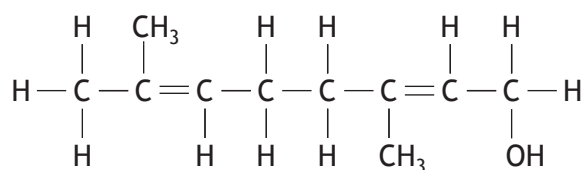

3,7-dimethylocta-2,6-dien-1-ol

Linalool can also be present. Its structural formula is shown.

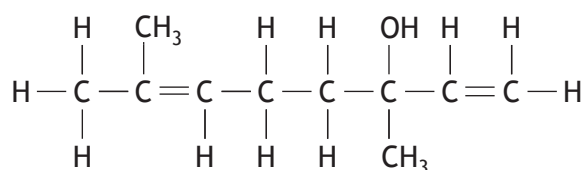

(A) State the systematic name for linalool.

1

(B) Explain why linalool can be classified as a tertiary alcohol.

1



4. (continued)

- (e) Coumarin is another compound found in the brand name perfume. It is present in the spice cinnamon and can be harmful if eaten in large quantities.

The European Food Safety Authority gives a tolerable daily intake of coumarin at 0.10 mg per kilogram of body weight.

1.0 kg of cinnamon powder from a particular source contains 4.4 g of coumarin. Calculate the mass of cinnamon powder, in g, which would need to be consumed by an adult weighing 75 kg to reach the tolerable daily intake.

2

[Turn over



* X 7 1 3 7 6 0 1 1 5 *

5. **Patterns in the Periodic Table**

The Periodic Table is an arrangement of all the known elements in order of increasing atomic number. The reason why the elements are arranged as they are in the Periodic Table is to fit them all, with their widely diverse physical and chemical properties, into a logical pattern.

Periodicity is the name given to regularly-occurring similarities in physical and chemical properties of the elements.

Some Groups exhibit striking similarity between their elements, such as Group 1, and in other Groups the elements are less similar to each other, such as Group 4, but each Group has a common set of characteristics.

Adapted from Royal Society of Chemistry, Visual Elements (rsc.org)

Using your knowledge of chemistry, comment on similarities and differences in the patterns of physical and chemical properties of elements in both Group 1 and Group 4.

3



* X 7 1 3 7 6 0 1 1 6 *

6. (b) (continued)

(ii) Another protein in egg white is conalbumin. The temperature of a conalbumin/dye mixture is gradually increased. The fluorescence is measured and a graph is produced.

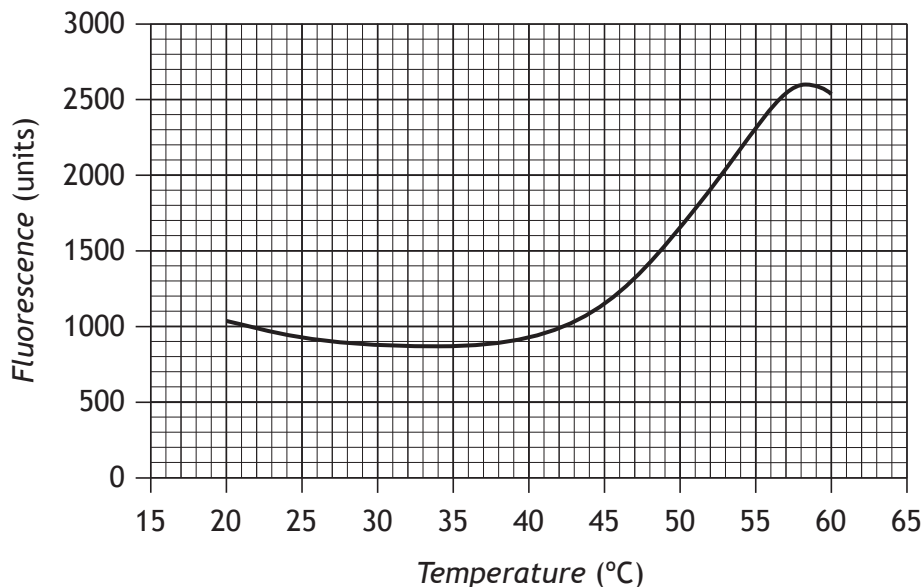

The melting temperature is the temperature at which the fluorescence is halfway between the highest and lowest fluorescence values.

Determine the melting temperature, in °C, for this protein.

1



6. (continued)

(c) Once cooked and eaten, the digestive system breaks the protein chains into amino acids with the help of enzymes.

(i) State the name of the digestion process where enzymes break down proteins into amino acids.

1

(ii)

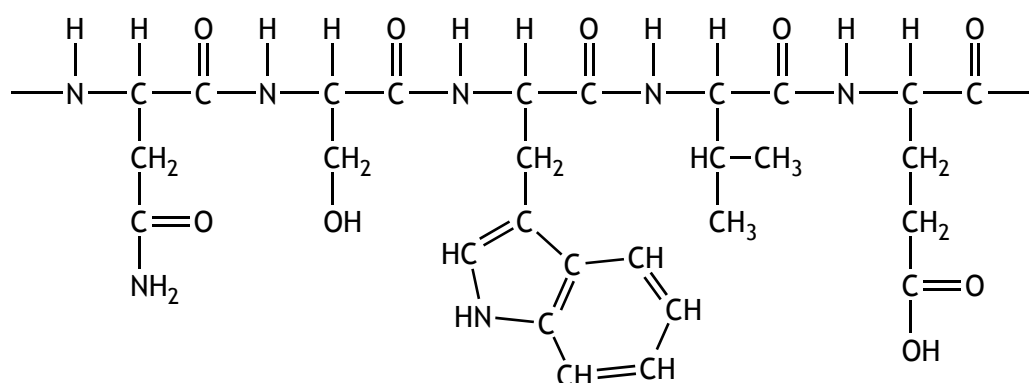

(A) State how many amino acid molecules joined to form this section of protein.

1

(B) Draw the structure of one amino acid that would be produced when this section of the protein chain is broken down.

1



7. Methanol can be used as a fuel, in a variety of different ways.

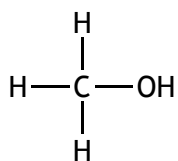

(a) An increasingly common use for methanol is as an additive in petrol.

Methanol has been tested as an additive in petrol at 118 g per litre of fuel.

Calculate the volume of carbon dioxide, in litres, that would be released by combustion of 118 g of methanol.

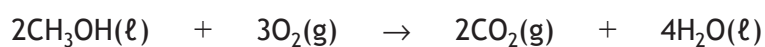

(Take the molar volume of carbon dioxide to be 24 litres mol⁻¹).

2



7. (continued)

(b) A student investigated the properties of methanol and ethanol.

(i) The student carried out experiments to determine the enthalpy of combustion of the alcohols.

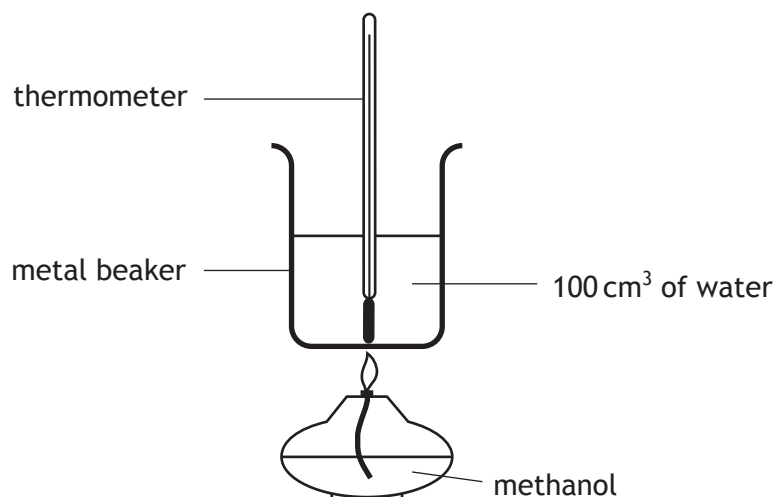

(A) The student carried out the first experiment as shown, but was told to repeat the experiment as the thermometer had been placed in the wrong position.

Suggest why the student's placing of the thermometer was incorrect.

1

(B) The student always used 100 cm³ of water.

State another variable that the student should have kept constant.

1

[Turn over



7. (b) (i) (continued)

(C) The student burned 1.07g of methanol and recorded a temperature rise of 23°C.

Calculate the enthalpy of combustion, in kJ mol^{-1} , for methanol using the student's results.

3

(ii) The student determined the density of the alcohols by measuring the mass of a volume of each alcohol.

The student's results are shown below.

	<i>Methanol</i>	<i>Ethanol</i>
Volume of alcohol (cm^3)	25.0	25.0
Mass of alcohol (g)	19.98	20.05
Density of alcohol (g cm^{-3})		0.802

Calculate the density, in g cm^{-3} , of methanol.

1



7. (continued)

- (c) Methanol is used as a source of hydrogen for fuel cells. The industrial process involves the reaction of methanol with steam.

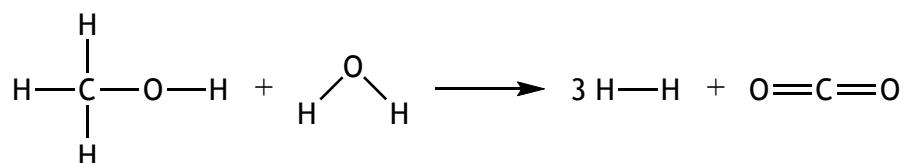

- (i) State why it is important for chemists to predict whether reactions in an industrial process are exothermic or endothermic. 1
- (ii) Using bond enthalpies from the data booklet, calculate the enthalpy change, in kJ mol^{-1} , for the reaction of methanol with steam. 2

[Turn over



8. Sodium carbonate is used in the manufacture of soaps, glass and paper as well as the treatment of water.

MARKS DO NOT WRITE IN THIS MARGIN

One industrial process used to make sodium carbonate is the Solvay process.

The Solvay process involves several different chemical reactions.

It starts with heating calcium carbonate to produce carbon dioxide, which is transferred to a reactor where it reacts with ammonia and brine. The products of the reactor are solid sodium hydrogencarbonate and ammonium chloride which are passed into a separator.

The sodium hydrogencarbonate is heated to decompose it into the product sodium carbonate along with carbon dioxide and water. To recover ammonia the ammonium chloride from the reactor is reacted with calcium oxide produced by heating the calcium carbonate. Calcium chloride is a by-product of the ammonia recovery process.

- (a) Using the information above, complete the flow chart by adding the names of the chemicals involved.

2

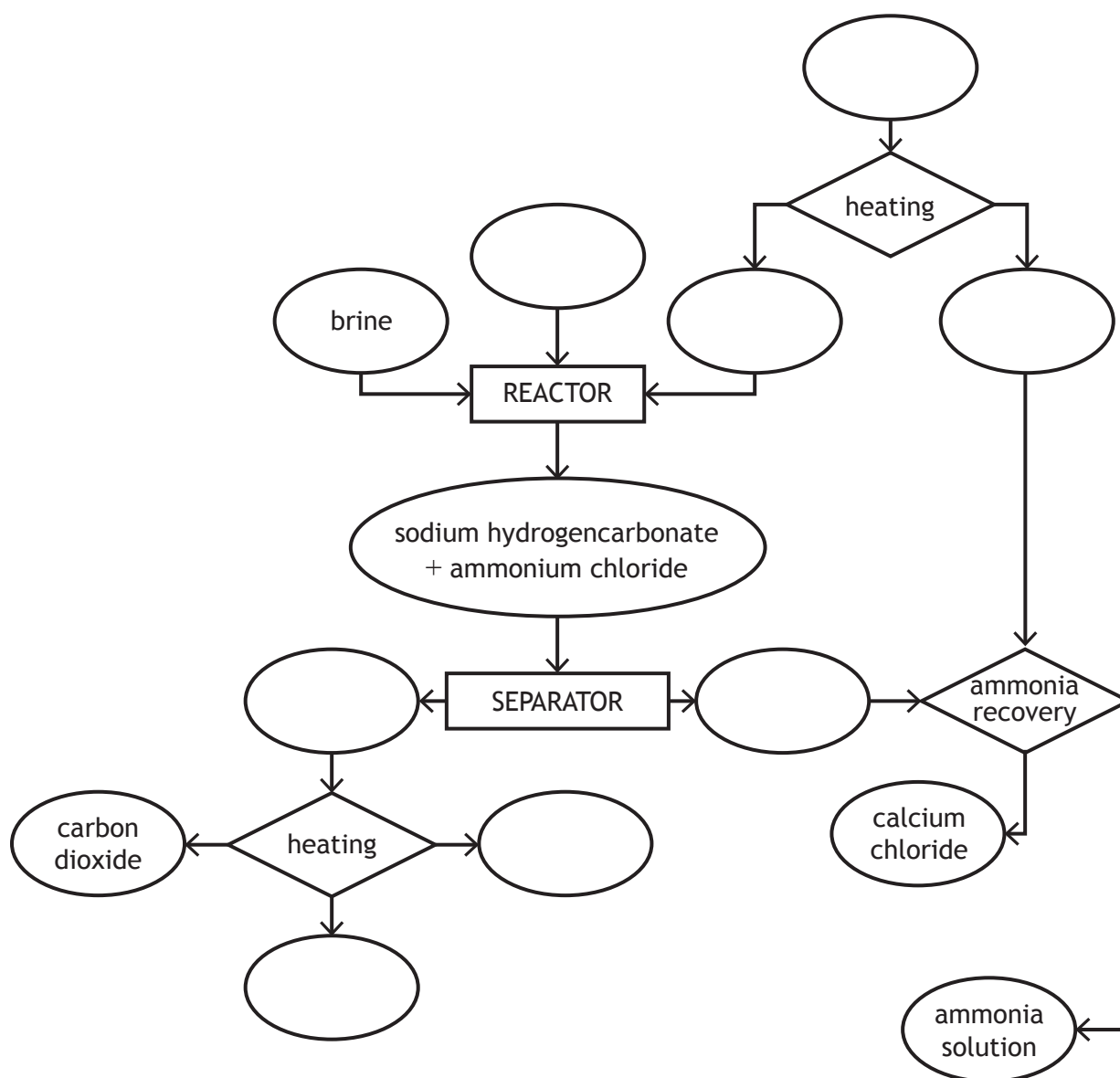

8 (continued)

- (b) The reaction that produces the solid sodium hydrogencarbonate involves the following equilibrium:

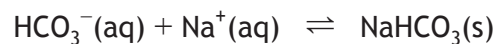

Brine is a concentrated sodium chloride solution.

Explain fully why using a concentrated sodium chloride solution encourages production of sodium hydrogencarbonate as a solid.

2

[Turn over



* X 7 1 3 7 6 0 1 2 5 *

MARKS DO NOT WRITE IN THIS MARGIN

9. Occasionally, seabirds can become contaminated with hydrocarbons from oil spills. This causes problems for birds because their feathers lose their waterproofing, making the birds susceptible to temperature changes and affecting their buoyancy. If the birds attempt to clean themselves to remove the oil, they may swallow the hydrocarbons causing damage to their internal organs.

Contaminated seabirds can be cleaned by rubbing vegetable oil into their feathers and feet before the birds are rinsed with diluted washing-up liquid.

Using your knowledge of chemistry, comment on the problems created for seabirds by oil spills and the actions taken to treat affected birds.

3



* X 7 1 3 7 6 0 1 2 6 *

[Turn over for Question 10 on *Page twenty-eight*

DO NOT WRITE ON THIS PAGE



* X 7 1 3 7 6 0 1 2 7 *

10. Plants require trace metal nutrients, such as zinc, for healthy growth. Zinc ions are absorbed from soil through the plant roots.

The zinc ion concentration in a solution can be found by adding a compound which gives a blue colour to the solution with zinc ions. The concentration of zinc ions is determined by measuring the absorption of light by the blue solution. The higher the concentration of zinc ions in a solution, the more light is absorbed.

A student prepared a stock solution with a zinc ion concentration of 1 g l^{-1} . Samples from this were diluted to produce solutions of known zinc ion concentration.

- (a) The stock solution was prepared by adding 1.00 g of zinc metal granules to 20 cm^3 of 2 mol l^{-1} sulfuric acid in a 1000 cm^3 standard flask.

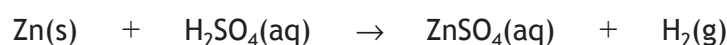

The flask was left for 24 hours, without a stopper. The solution was then diluted to 1000 cm^3 with water.

- (i) Explain fully why the flask was left for 24 hours, without a stopper. 2

- (ii) Explain why the student should use deionised water or distilled water, rather than tap water, when preparing the stock solution. 1

- (b) Solutions of known zinc ion concentration were prepared by transferring accurate volumes of the stock solution to standard flasks and diluting with water.

- (i) Name the piece of apparatus which should be used to transfer 10 cm^3 of stock solution to a standard flask. 1



10. (b) (continued)

(ii) Calculate the concentration, in mg l^{-1} , of the solution prepared by transferring 10 cm^3 of the 1 g l^{-1} stock solution to a 1000 cm^3 standard flask and making up to the mark.

1

(c) The light absorbance of different solutions was measured and the results plotted.

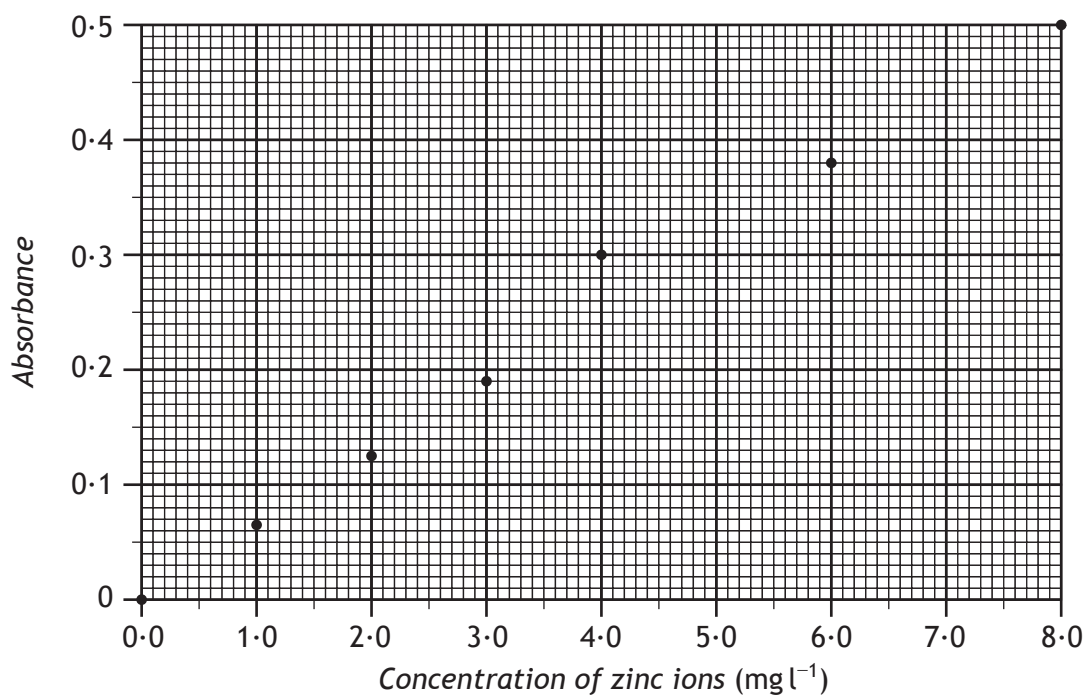

A solution prepared from a soil sample was tested to determine the concentration of zinc ions. The solution had an absorbance of 0.3.

Determine the concentration, in mg l^{-1} , of zinc ions in the solution.

1



11.

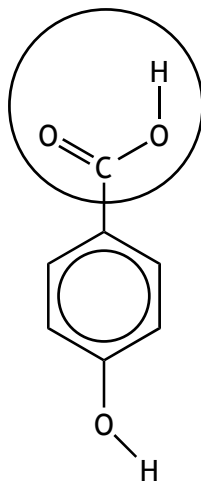

4-hydroxybenzoic acid

4-hydroxybenzoic acid can react with alcohols to form compounds known as parabens.

(a) Name the functional group circled in the structure of 4-hydroxybenzoic acid.

1

(b) Name the type of reaction taking place when parabens are formed.

1

(c) Draw the paraben formed when 4-hydroxybenzoic acid reacts with ethanol.

1

MARKS
DO NOT
WRITE IN
THIS
MARGIN



11. (continued)

(d) Parabens can be used as preservatives in cosmetics and toiletries.

Parabens are absorbed into the body through the skin. The following table indicates the absorption of some parabens.

<i>Paraben</i>	<i>Absorption</i> ($\mu\text{g cm}^{-2}$)
Methyl	32.50
Ethyl	20.74
Propyl	11.40
Butyl	7.74
Hexyl	1.60

State a conclusion that can be drawn from the information in the table. **1**

[Turn over



12. (a) The concentration of sodium hypochlorite in swimming pool water can be determined by redox titration.

Step 1

A 100.0 cm³ sample from the swimming pool is first reacted with an excess of acidified potassium iodide solution forming iodine.

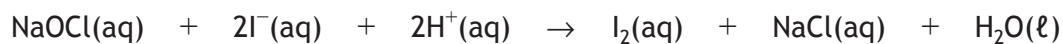

Step 2

The iodine formed in step 1 is titrated using a standard solution of sodium thiosulfate, concentration 0.00100 mol l⁻¹. A small volume of starch solution is added towards the endpoint.

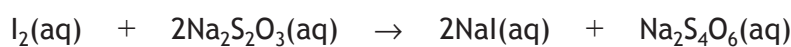

- (i) Describe in detail how a burette should be prepared and set up, ready to begin the titration.

3

- (ii) Write the ion-electron equation for the oxidation reaction occurring in step 1.

1



* X 7 1 3 7 6 0 1 3 2 *

12. (a) (continued)

(iii) Calculate the concentration, in mol l^{-1} , of sodium hypochlorite in the swimming pool water, if an average volume of 12.4 cm^3 of sodium thiosulfate was required.

3

(b) The level of hypochlorite in swimming pools needs to be maintained between 1 and 3 parts per million (1 – 3 ppm).

400 cm^3 of a commercial hypochlorite solution will raise the hypochlorite level of 45 000 litres of water by 1 ppm.

Calculate the volume of hypochlorite solution that will need to be added to an Olympic-sized swimming pool, capacity 2 500 000 litres, to raise the hypochlorite level from 1 ppm to 3 ppm.

2

[Turn over



* X 7 1 3 7 6 0 1 3 3 *

12. (continued)

- (c) The familiar chlorine smell of a swimming pool is not due to chlorine but compounds called chloramines. Chloramines are produced when the hypochlorite ion reacts with compounds such as ammonia, produced by the human body.



Chloramines are less soluble in water than ammonia due to the polarities of the molecules, and so readily escape into the atmosphere, causing irritation to the eyes.

- (i) Explain the difference in polarities of ammonia and trichloramine molecules.



ammonia

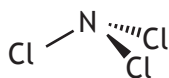

trichloramine

2



* X 7 1 3 7 6 0 1 3 4 *

12. (c) (continued)

- (ii) Chloramines can be removed from water using ultraviolet light treatment.

One step in the process is the formation of free radicals.



State what is meant by the term free radical.

1

- (iii) Another step in the process is shown below.

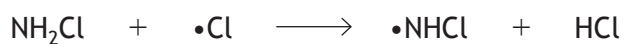

State the name for this type of step in a free radical reaction.

1

[Turn over for Question 13 on *Page thirty-six*]



* X 7 1 3 7 6 0 1 3 5 *

13. (a) One test for glucose involves Fehling's solution.

Circle the part of the glucose molecule that reacts with Fehling's solution.

1

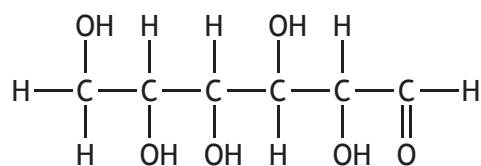

(b) In solution, sugar molecules exist in an equilibrium in straight-chain and ring forms.

To change from the straight-chain form to the ring form, the oxygen of the hydroxyl on carbon number 5 joins to the carbonyl carbon. This is shown below for glucose.

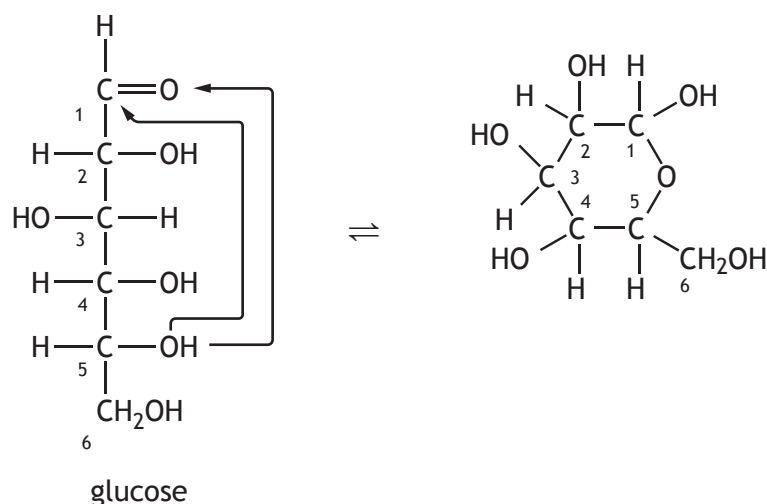

Draw the structure of a ring form for fructose.

1

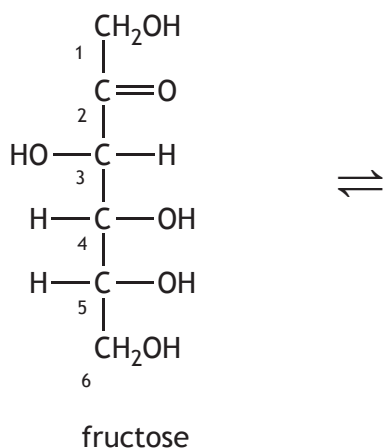

[END OF QUESTION PAPER]



ADDITIONAL DIAGRAM FOR USE IN QUESTION 3 (a) (i)

MARKS
DO NOT
WRITE IN
THIS
MARGIN

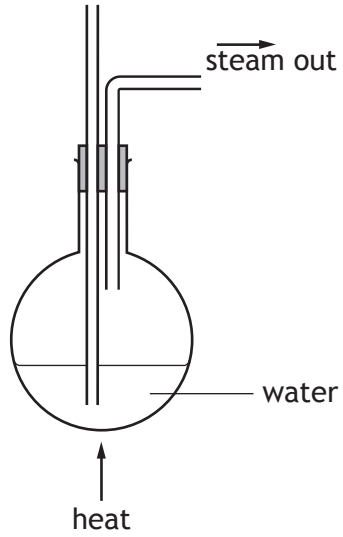

ADDITIONAL SPACE FOR ANSWERS AND ROUGH WORK

MARKS

DO NOT
WRITE IN
THIS
MARGIN



* X 7 1 3 7 6 0 1 3 8 *

ADDITIONAL SPACE FOR ANSWERS AND ROUGH WORK

MARKS

DO NOT
WRITE IN
THIS
MARGIN



* X 7 1 3 7 6 0 1 3 9 *

ACKNOWLEDGEMENTS

Question 5 – Extract is adapted from “*Royal Society of Chemistry, Visual Elements.*” Reproduced by kind permission of the Royal Society of Chemistry.



* X 7 1 3 7 6 0 1 4 0 *