



National
Qualifications
2016

X713/76/02

**Chemistry
Section 1 — Questions**

WEDNESDAY, 18 MAY

9:00 AM – 11:30 AM

Instructions for the completion of Section 1 are given on *Page 02* of your question and answer booklet X713/76/01.

Record your answers on the answer grid on *Page 03* of your question and answer booklet.

Reference may be made to the Chemistry Higher and Advanced Higher Data Booklet.

Before leaving the examination room you must give your question and answer booklet to the Invigilator; if you do not you may lose all the marks for this paper.



* X 7 1 3 7 6 0 2 *

SECTION 1 — 20 marks

Attempt ALL questions

1. Particles with the same electron arrangement are said to be isoelectronic.
Which of the following compounds contains ions which are isoelectronic?

- A Na_2S
- B MgCl_2
- C KBr
- D CaCl_2

2. Which line in the table is correct for the polar covalent bond in hydrogen chloride?

	<i>Relative position of bonding electrons</i>	<i>Dipole notation</i>
A	$\text{H} \text{ --- } \overset{\cdot\cdot}{\underset{\cdot\cdot}{\text{Cl}}}$	$\begin{array}{cc} \delta+ & \delta- \\ \text{H} \text{ --- } & \text{Cl} \end{array}$
B	$\text{H} \overset{\cdot\cdot}{\underset{\cdot\cdot}{\text{---}}} \text{Cl}$	$\begin{array}{cc} \delta+ & \delta- \\ \text{H} \text{ --- } & \text{Cl} \end{array}$
C	$\text{H} \text{ --- } \overset{\cdot\cdot}{\underset{\cdot\cdot}{\text{Cl}}}$	$\begin{array}{cc} \delta- & \delta+ \\ \text{H} \text{ --- } & \text{Cl} \end{array}$
D	$\text{H} \overset{\cdot\cdot}{\underset{\cdot\cdot}{\text{---}}} \text{Cl}$	$\begin{array}{cc} \delta- & \delta+ \\ \text{H} \text{ --- } & \text{Cl} \end{array}$

3. Which of the following compounds has the greatest ionic character?

- A Caesium fluoride
- B Caesium iodide
- C Sodium fluoride
- D Sodium iodide

4. The diagram below shows the energy profiles for a reaction carried out with and without a catalyst.

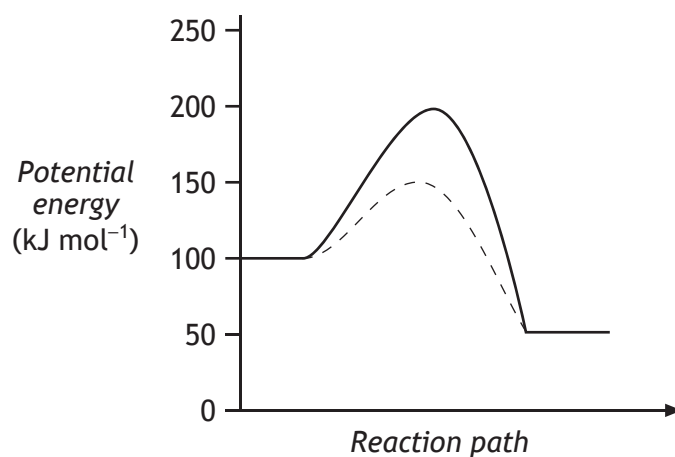

What is the enthalpy change, in kJ mol⁻¹, for the catalysed reaction?

- A -100
 - B -50
 - C +50
 - D +100
5. Limonene is a terpene molecule present in lemons.

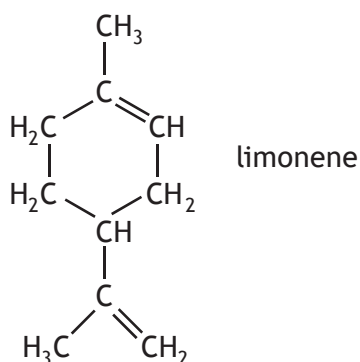

How many isoprene units are joined together in a limonene molecule?

- A 1
- B 2
- C 3
- D 4

[Turn over

6. The following molecules give flavour to food.

Which of the following flavour molecules would be most likely to be retained in the food when the food is cooked in water?

A

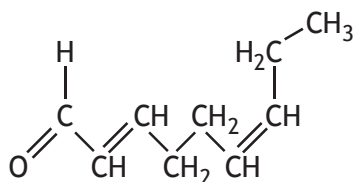

B

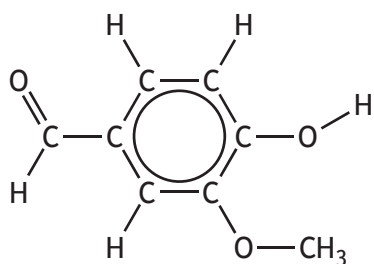

C

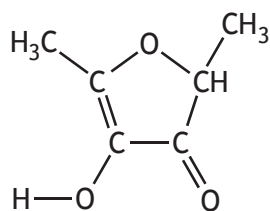

D

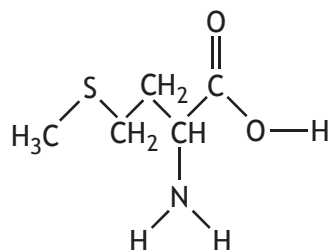

7. vegetable oil \longrightarrow vegetable fat

Which of the following reactions brings about the above change?

- A Hydrolysis
- B Condensation
- C Hydrogenation
- D Dehydrogenation

8. The rate of hydrolysis of protein, using an enzyme, was studied at different temperatures. Which of the following graphs would be obtained?

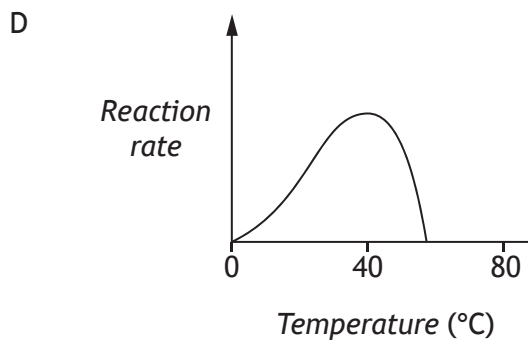
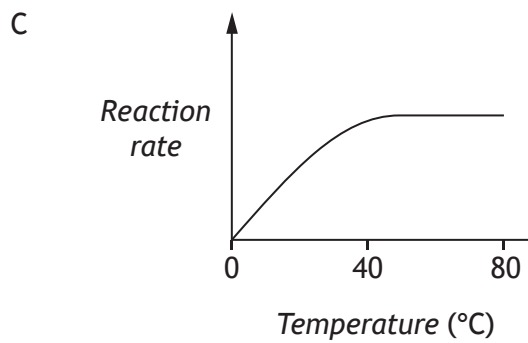
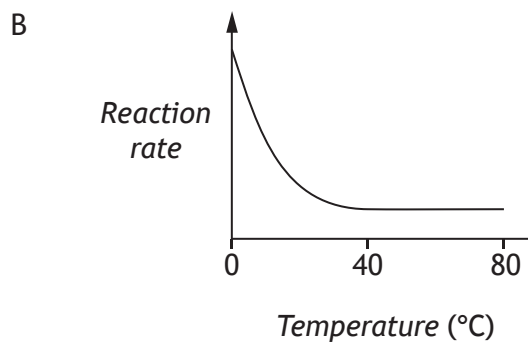
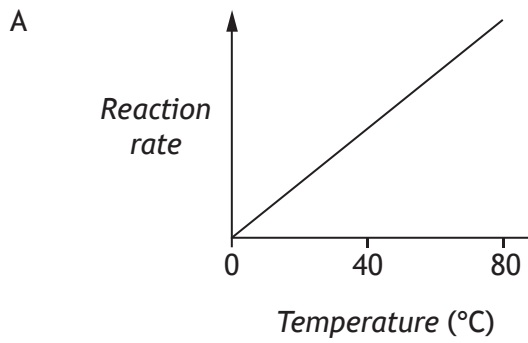

[Turn over

9. Which of the following is the salt of a long-chain fatty acid?
- A Fat
 - B Oil
 - C Soap
 - D Glycerol
10. Emulsifiers for use in food are commonly made by reacting edible oils with
- A esters
 - B glycerol
 - C fatty acids
 - D amino acids.
11. The equation for the reduction reaction taking place when ethanal reacts with Tollens' reagent is
- A $\text{Cu}^{2+}(\text{aq}) + \text{e}^{-} \rightarrow \text{Cu}^{+}(\text{aq})$
 - B $\text{Ag}^{+}(\text{aq}) + \text{e}^{-} \rightarrow \text{Ag}(\text{s})$
 - C $\text{Cr}_2\text{O}_7^{2-}(\text{aq}) + 14\text{H}^{+}(\text{aq}) + 6\text{e}^{-} \rightarrow 2\text{Cr}^{3+}(\text{aq}) + 7\text{H}_2\text{O}(\ell)$
 - D $\text{MnO}_4^{-}(\text{aq}) + 8\text{H}^{+}(\text{aq}) + 5\text{e}^{-} \rightarrow \text{Mn}^{2+}(\text{aq}) + 4\text{H}_2\text{O}(\ell)$
12. The name of the compound with structure:

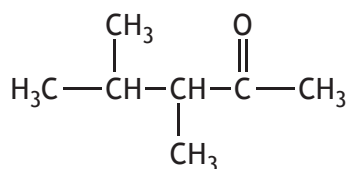

is

- A 2,3-dimethylpentan-4-one
- B 2,3-dimethylpentan-2-al
- C 3,4-dimethylpentan-2-one
- D 3,4-dimethylpentan-2-al.

17. An oxidising agent

- A gains electrons and is oxidised
- B loses electrons and is oxidised
- C gains electrons and is reduced
- D loses electrons and is reduced.

18. During a redox process in acid solution, chlorate ions, $\text{ClO}_3^-(\text{aq})$, are converted into chlorine, $\text{Cl}_2(\text{g})$.

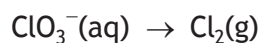

The numbers of $\text{H}^+(\text{aq})$ and $\text{H}_2\text{O}(\ell)$ required to balance the ion-electron equation for the formation of 1 mol of $\text{Cl}_2(\text{g})$ are, respectively

- A 3 and 6
- B 6 and 3
- C 6 and 12
- D 12 and 6.

19. Which of the following ions could be used to oxidise iodide ions to iodine?

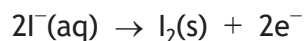

- A $\text{SO}_4^{2-}(\text{aq})$
- B $\text{SO}_3^{2-}(\text{aq})$
- C $\text{Cr}^{3+}(\text{aq})$
- D $\text{Cr}_2\text{O}_7^{2-}(\text{aq})$

20.

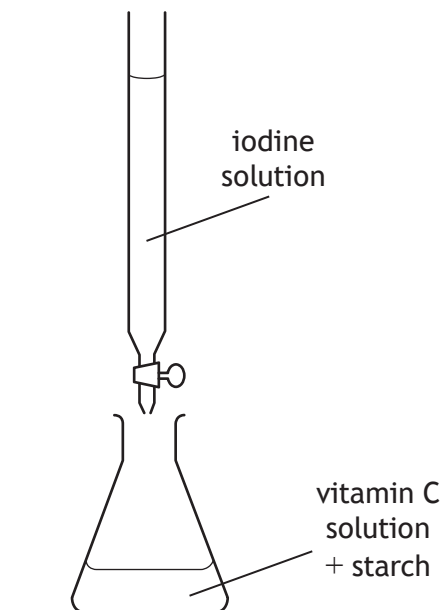

A student was carrying out a titration to establish the concentration of vitamin C using iodine solution.

Which of the following would help the student achieve a precise end-point?

- A Placing a white tile underneath the conical flask
- B Using the bottom of the meniscus when reading the burette
- C Repeating titrations
- D Carrying out a rough titration first

**[END OF SECTION 1. NOW ATTEMPT THE QUESTIONS IN SECTION 2
OF YOUR QUESTION AND ANSWER BOOKLET.]**

[BLANK PAGE]

DO NOT WRITE ON THIS PAGE

[BLANK PAGE]

DO NOT WRITE ON THIS PAGE

[BLANK PAGE]

DO NOT WRITE ON THIS PAGE

FOR OFFICIAL USE



National
Qualifications
2016

Mark

X713/76/01

**Chemistry
Section 1 — Answer Grid
and Section 2**

WEDNESDAY, 18 MAY

9:00 AM – 11:30 AM



* X 7 1 3 7 6 0 1 *

Fill in these boxes and read what is printed below.

Full name of centre

Town

Forename(s)

Surname

Number of seat

Date of birth

Day

Month

Year

Scottish candidate number

Total marks — 100

SECTION 1 — 20 marks

Attempt ALL questions.

Instructions for completion of Section 1 are given on *Page 02*.

SECTION 2 — 80 marks

Attempt ALL questions

Reference may be made to the Chemistry Higher and Advanced Higher Data Booklet.

Write your answers clearly in the spaces provided in this booklet. Additional space for answers and rough work is provided at the end of this booklet. If you use this space you must clearly identify the question number you are attempting. Any rough work must be written in this booklet. You should score through your rough work when you have written your final copy.

Use **blue** or **black** ink.

Before leaving the examination room you must give this booklet to the Invigilator; if you do not you may lose all the marks for this paper.



* X 7 1 3 7 6 0 1 0 1 *

The questions for Section 1 are contained in the question paper X713/76/02.
Read these and record your answers on the answer grid on *Page 03* opposite.
Use **blue** or **black** ink. Do NOT use gel pens or pencil.

1. The answer to each question is **either** A, B, C or D. Decide what your answer is, then fill in the appropriate bubble (see sample question below).
2. There is **only one correct** answer to each question.
3. Any rough working should be done on the additional space for answers and rough work at the end of this booklet.

Sample Question

To show that the ink in a ball-pen consists of a mixture of dyes, the method of separation would be:

- A fractional distillation
- B chromatography
- C fractional crystallisation
- D filtration.

The correct answer is **B**—chromatography. The answer **B** bubble has been clearly filled in (see below).

A	B	C	D
<input type="radio"/>	<input checked="" type="radio"/>	<input type="radio"/>	<input type="radio"/>

Changing an answer

If you decide to change your answer, cancel your first answer by putting a cross through it (see below) and fill in the answer you want. The answer below has been changed to **D**.

A	B	C	D
<input type="radio"/>	<input checked="" type="radio"/>	<input type="radio"/>	<input checked="" type="radio"/>

If you then decide to change back to an answer you have already scored out, put a tick (✓) to the **right** of the answer you want, as shown below:

A	B	C	D	or	A	B	C	D
<input type="radio"/>	<input checked="" type="radio"/>	<input type="radio"/>	<input checked="" type="radio"/>		<input type="radio"/>	<input checked="" type="radio"/>	<input type="radio"/>	<input type="radio"/>



SECTION 1 — Answer Grid



	A	B	C	D
1	<input type="radio"/>	<input type="radio"/>	<input type="radio"/>	<input type="radio"/>
2	<input type="radio"/>	<input type="radio"/>	<input type="radio"/>	<input type="radio"/>
3	<input type="radio"/>	<input type="radio"/>	<input type="radio"/>	<input type="radio"/>
4	<input type="radio"/>	<input type="radio"/>	<input type="radio"/>	<input type="radio"/>
5	<input type="radio"/>	<input type="radio"/>	<input type="radio"/>	<input type="radio"/>
6	<input type="radio"/>	<input type="radio"/>	<input type="radio"/>	<input type="radio"/>
7	<input type="radio"/>	<input type="radio"/>	<input type="radio"/>	<input type="radio"/>
8	<input type="radio"/>	<input type="radio"/>	<input type="radio"/>	<input type="radio"/>
9	<input type="radio"/>	<input type="radio"/>	<input type="radio"/>	<input type="radio"/>
10	<input type="radio"/>	<input type="radio"/>	<input type="radio"/>	<input type="radio"/>
11	<input type="radio"/>	<input type="radio"/>	<input type="radio"/>	<input type="radio"/>
12	<input type="radio"/>	<input type="radio"/>	<input type="radio"/>	<input type="radio"/>
13	<input type="radio"/>	<input type="radio"/>	<input type="radio"/>	<input type="radio"/>
14	<input type="radio"/>	<input type="radio"/>	<input type="radio"/>	<input type="radio"/>
15	<input type="radio"/>	<input type="radio"/>	<input type="radio"/>	<input type="radio"/>
16	<input type="radio"/>	<input type="radio"/>	<input type="radio"/>	<input type="radio"/>
17	<input type="radio"/>	<input type="radio"/>	<input type="radio"/>	<input type="radio"/>
18	<input type="radio"/>	<input type="radio"/>	<input type="radio"/>	<input type="radio"/>
19	<input type="radio"/>	<input type="radio"/>	<input type="radio"/>	<input type="radio"/>
20	<input type="radio"/>	<input type="radio"/>	<input type="radio"/>	<input type="radio"/>



[BLANK PAGE]

DO NOT WRITE ON THIS PAGE



* X 7 1 3 7 6 0 1 0 4 *

[Turn over for next question

DO NOT WRITE ON THIS PAGE



* X 7 1 3 7 6 0 1 0 5 *

SECTION 2 — 80 marks

Attempt ALL questions

1. Hydrogen peroxide gradually decomposes into water and oxygen, according to the following equation.

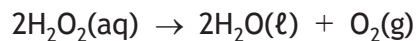

- (a) At room temperature, the reaction is very slow. It can be speeded up by heating the reaction mixture.

State why increasing the temperature causes an increase in reaction rate.

1

- (b) (i) The reaction can also be speeded up by adding a catalyst, such as manganese dioxide.

To determine the rate of the reaction, the volume of gas produced in a given time can be measured.

Complete the diagram below to show how the gas produced can be collected and measured.

1

(An additional diagram, if required, can be found on *Page 38*).

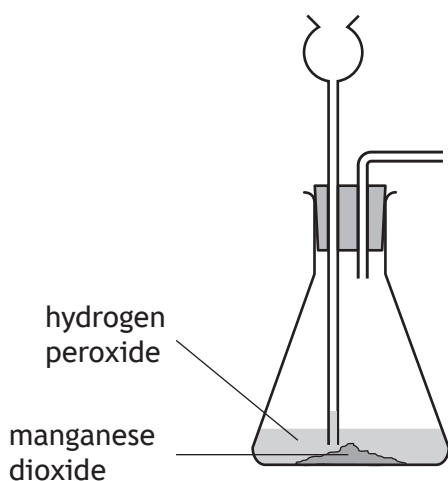

1. (b) (continued)

- (ii) The concentration of hydrogen peroxide is often described as a volume strength. This relates to the volume of oxygen that can be produced from a hydrogen peroxide solution.

volume of oxygen produced	=	volume strength	×	volume of hydrogen peroxide solution
---------------------------	---	-----------------	---	--------------------------------------

In an experiment, 74 cm³ of oxygen was produced from 20 cm³ of hydrogen peroxide solution.

Calculate the volume strength of the hydrogen peroxide.

1

- (c) Hydrogen peroxide can react with potassium iodide to produce water and iodine.

A student carried out an experiment to investigate the effect of changing the concentration of potassium iodide on reaction rate. The results are shown below.

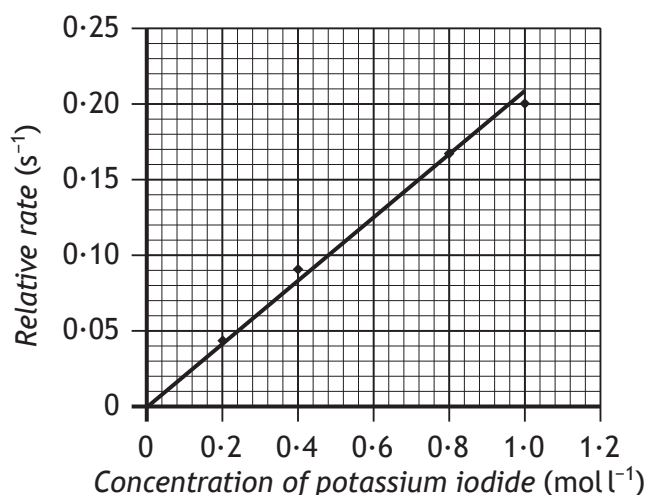

Calculate the time taken, in s, for the reaction when the concentration of potassium iodide used was 0.6 mol l⁻¹.

1



2. (a) Graph 1 shows the sizes of atoms and ions for elements in the third period of the Periodic Table.

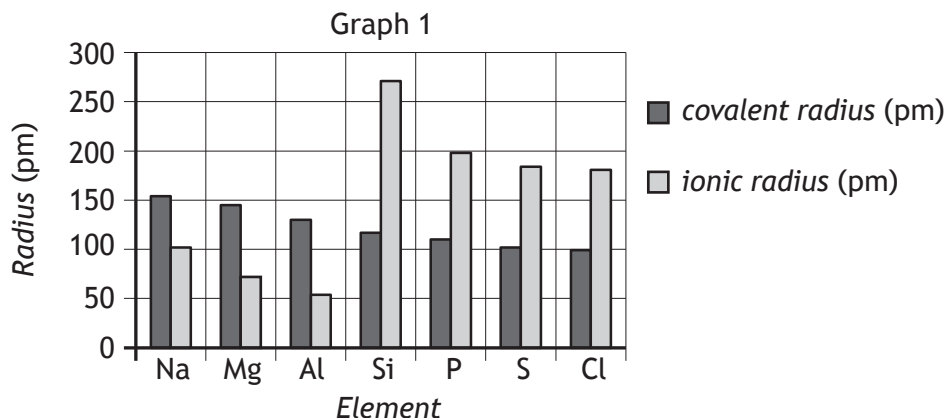

The covalent radius is a measure of the size of an atom.

- (i) Explain why covalent radius decreases across the period from sodium to chlorine.

1

- (ii) Explain **fully** why the covalent radius of sodium is larger than the ionic radius of sodium.

2



2. (continued)

- (b) Graph 2 shows the first and second ionisation energies of elements in Group 1 of the Periodic Table.

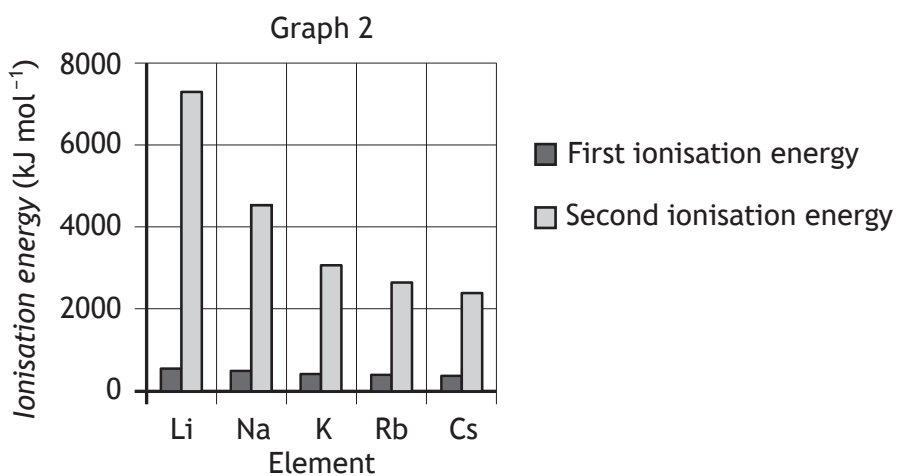

- (i) Explain why the first ionisation energy decreases going down Group 1. 1

- (ii) Explain **fully** why the second ionisation energy is much greater than the first ionisation energy for Group 1 elements. 2



2. (continued)

- (c) The lattice enthalpy is the energy needed to completely separate the ions in one mole of an ionic solid.

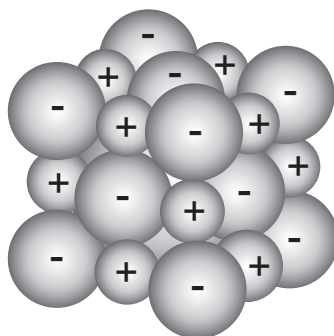

Table 1 shows the size of selected ions.

Table 1

<i>Ion</i>	Li ⁺	Na ⁺	K ⁺	Rb ⁺	F ⁻	Cl ⁻
<i>Ionic radius (pm)</i>	76	102	138	152	133	181

Table 2 shows the lattice enthalpies, in kJ mol⁻¹, for some Group 1 halides.

Table 2

<i>Ions</i>	F ⁻	Cl ⁻
Li ⁺	1030	834
Na ⁺	910	769
K ⁺	808	701
Rb ⁺		658

- (i) Predict the lattice enthalpy, in kJ mol⁻¹, for rubidium fluoride. 1
- (ii) Write a general statement linking lattice enthalpy to ionic radii. 1



3. Phosphine (PH₃) is used as an insecticide in the storage of grain.

Phosphine can be produced by the reaction of water with aluminium phosphide



(a) State the type of bonding and structure in phosphine.

1

(b) 2.9 kg of aluminium phosphide were used in a phosphine generator.

Calculate the volume of phosphine gas, in litres, that would have been produced.

(Take the volume of 1 mole of phosphine to be 24 litres).

2

(c) Carbon dioxide is fed into the phosphine generator to keep the phosphine concentration less than 2.6%. Above this level phosphine can ignite due to the presence of diphosphane, P₂H₄(g), as an impurity.

Draw a structural formula for diphosphane.

1



* X 7 1 3 7 6 0 1 1 1 *

4. The viscosity of alcohols depends on a number of factors:

- the strength of intermolecular forces
- the size of the molecule
- temperature

These factors can be investigated using alcohols and apparatus from the lists below.

<i>Alcohols</i>	<i>Apparatus</i>
methanol	beakers
ethanol	funnels
propan-1-ol	burettes
ethane-1,2-diol	measuring cylinders
butan-1-ol	plastic syringes
propane-1,3-diol	glass tubing
pentan-1-ol	stoppers
propane-1,2,3-triol	timer
	metre stick
	ball bearing
	clamp stands
	kettle
	thermometer

Using your knowledge of chemistry, identify the alcohols and apparatus that you would select and describe how these could be used to investigate one, or more, of the factors affecting the viscosity of alcohols.

3



MARKS

DO NOT
WRITE IN
THIS
MARGIN

4. (continued)

Answer space



* X 7 1 3 7 6 0 1 1 3 *

5. When fats and oils are hydrolysed, mixtures of fatty acids are obtained.

(a) Name the other product obtained in this reaction.

1

(b) The table below shows the percentage composition of the fatty acid mixtures obtained by hydrolysis of coconut oil and olive oil.

Class of fatty acids produced on hydrolysis	Name of oil	
	Coconut oil	Olive oil
Saturated	91	14
Monounsaturated	6	72
Polyunsaturated	3	14

(i) One of the fatty acids produced by the hydrolysis of olive oil is linoleic acid, $C_{17}H_{31}COOH$.

State the class of fatty acid to which linoleic acid belongs.

1

(ii) Hydrolysed coconut oil contains the fatty acid, caprylic acid, with the formula $CH_3(CH_2)_6COOH$.

State the systematic name for caprylic acid.

1

(c) The degree of unsaturation of oil can be tested by adding drops of bromine solution to the oil. Bromine adds across carbon to carbon double bonds in the fatty acid chains.

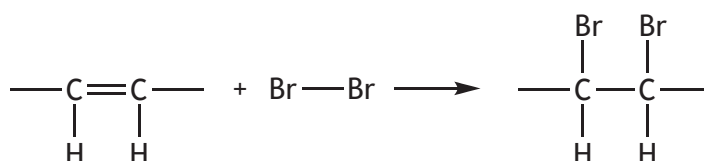

5. (c) (continued)

The following apparatus can be used to compare the degree of unsaturation of different oils.

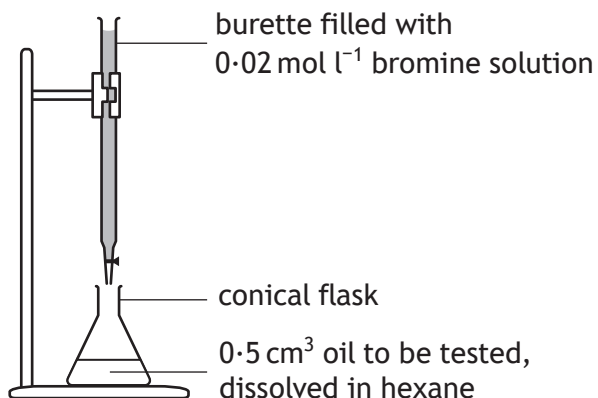

(i) Describe how this apparatus could be used to show that olive oil has a greater degree of unsaturation than coconut oil. 2

(ii) Suggest why hexane is used as the solvent, rather than water. 1

(iii) Coconut oil has a melting point of 25 °C. Olive oil has a melting point of -6 °C.
Give two reasons why coconut oil has a higher melting point than olive oil. 2



6. Peptide molecules can be classified according to the number of amino acid units joined by peptide bonds in the molecule.

<i>Type of peptide</i>	<i>Example of amino acid sequence</i>
dipeptide	aspartic acid-phenylalanine
tripeptide	isoleucine-proline-proline
tetrapeptide	lysine-proline-proline-arginine
pentapeptide	serine-glycine-tyrosine-alanine-leucine
	alanine-glycine-valine-proline-tyrosine-serine
polypeptide	many amino acids

- (a) Complete the table to identify the type of peptide with the following amino acid sequence

alanine-glycine-valine-proline-tyrosine-serine

1

- (b) Partial hydrolysis of another pentapeptide molecule gave a mixture of three smaller peptide molecules with the following amino acid sequences.

leucine-glycine-valine

isoleucine-leucine

glycine-valine-serine

Write the amino acid sequence for the original pentapeptide molecule.

1

..... - - - -

- (c) Some amino acids needed to form polypeptides cannot be produced in the human body.

State the term used to describe amino acids that the body cannot make.

1



6. (continued)

- (d) Paper chromatography is often used to analyse the mixtures of amino acids produced when peptides are broken down.

On a chromatogram, the retention factor R_f , for a substance can be a useful method of identifying the substance.

$$R_f = \frac{\text{distance moved by the substance}}{\text{maximum distance moved by the solvent}}$$

The structure of the pentapeptide methionine enkephalin was investigated.

A sample of the pentapeptide was completely hydrolysed into its constituent amino acids and this amino acid mixture was applied to a piece of chromatography paper and placed in a solvent.

The chromatogram obtained is shown below.

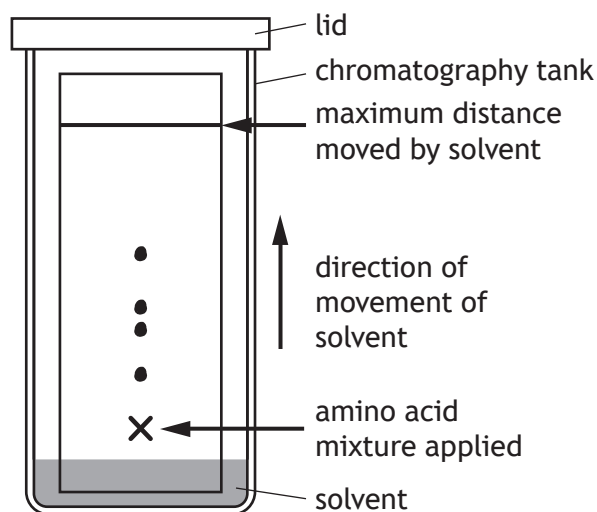

- (i) Suggest why only four spots were obtained on the chromatogram of the hydrolysed pentapeptide. 1

- (ii) It is known that this amino acid mixture contains the amino acid methionine. The R_f value for methionine in this solvent is 0.40.

Draw a circle around the spot on the chromatogram that corresponds to methionine. 1



6. (continued)

(e) Over the last decade several families of extremely stable peptide molecules have been discovered, where the peptide chain forms a ring.

(i) A simple cyclic dipeptide is shown.

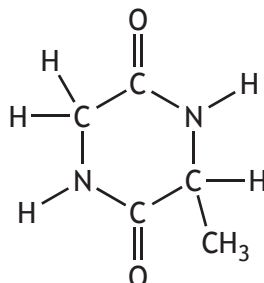

Draw a structural formula for one of the amino acids that would be formed on complete hydrolysis of the above cyclic dipeptide.

1

(ii) Alpha-amanitin is a highly toxic cyclic peptide found in death cap mushrooms. The lethal dose for humans is 100 mg per kg of body mass.

1.0 g of death cap mushrooms contains 250 mg of alpha-amanitin.

Calculate the minimum mass of death cap mushrooms that would contain the lethal dose for a 75 kg adult.

2



[Turn over for next question

DO NOT WRITE ON THIS PAGE



* X 7 1 3 7 6 0 1 1 9 *

7. Modern shellac nail varnishes are more durable and so last longer than traditional nail polish.

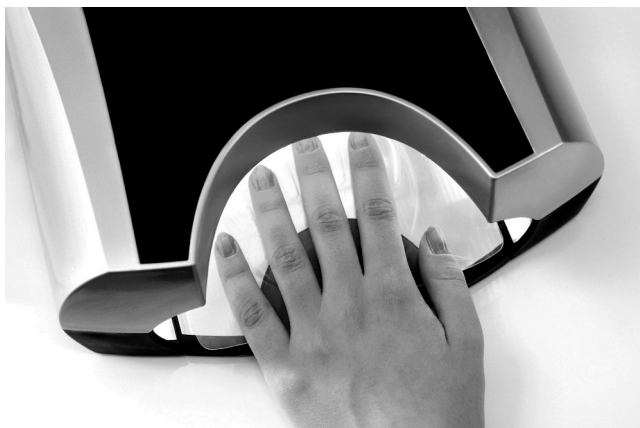

The shellac nail varnish is applied in thin layers to the nails and then the fingers are placed under a UV lamp.

- (a) The Skin Care Foundation has recommended that a sun-block is applied to the fingers and hand before using the lamp.

Suggest why the Skin Care Foundation makes this recommendation.

1

- (b) A *free radical* chain reaction takes place and the varnish hardens.

(i) State what is meant by the term *free radical*.

1



* X 7 1 3 7 6 0 1 2 0 *

7. (b) (continued)

- (ii) The shellac nail varnish contains a mixture of ingredients that take part in the free radical chain reaction.

One of the steps in the free radical chain reaction is:

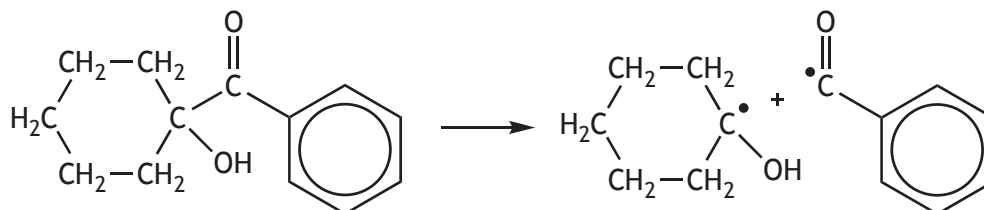

State the term used to describe this type of step in a free radical chain reaction.

1

- (iii) During the free radical chain reaction small molecules join to form large chain molecules.

One example of a small molecule used is

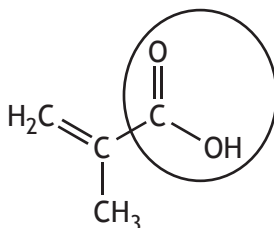

Name the functional group circled above.

1

- (iv) Alcohol wipes are used to finish the varnishing treatment. Alcohol wipes contain the alcohol propan-2-ol.

State why propan-2-ol can be described as a secondary alcohol.

1



7. (continued)

(c) Traditional nail varnishes use ethyl ethanoate and butyl ethanoate as solvents.

(i) Draw a structural formula for butyl ethanoate.

1

(ii) Ethyl ethanoate can be made in the laboratory using the following apparatus.

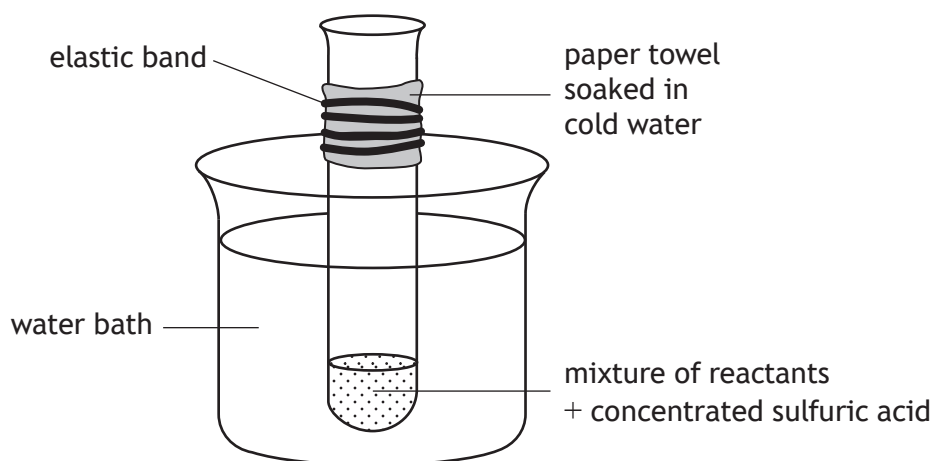

Suggest why a wet paper towel is wrapped around the test tube.

1



7. (c) (continued)

- (iii) A student used 2.5 g of ethanol and a slight excess of ethanoic acid to produce 2.9 g of ethyl ethanoate.

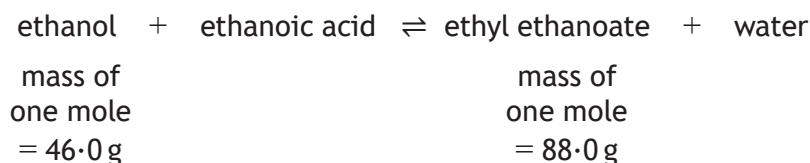

(One mole of ethanol reacts with one mole of ethanoic acid to produce one mole of ethyl ethanoate.)

Calculate the percentage yield of ethyl ethanoate.

2

- (iv) Name the type of reaction that takes place during the formation of ethyl ethanoate.

1

[Turn over



* X 7 1 3 7 6 0 1 2 3 *

8. Methanol (CH₃OH) is an important chemical in industry.

(a) Methanol is produced from methane in a two-step process.

In step 1, methane is reacted with steam as shown.

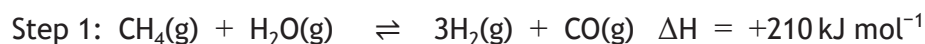

In step 2, hydrogen reacts with carbon monoxide.

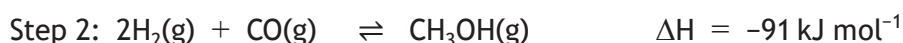

Complete the table to show the most favourable conditions to maximise the yield for each step.

2

	Temperature (High/Low)	Pressure (High/Low)
Step 1		
Step 2		

(b) Methanol reacts with compound X, in an addition reaction, to form methyl tertiary-butyl ether, an additive for petrol.

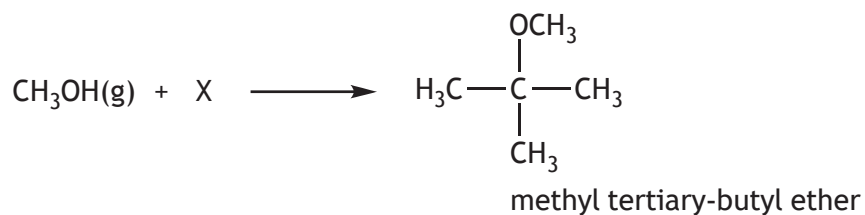

(i) Suggest a structure for compound X.

1

(ii) The atom economy of this reaction is 100%.

Explain what this means.

1



* X 7 1 3 7 6 0 1 2 4 *

8. (continued)

(c) Methanol can be converted to methanal as shown.

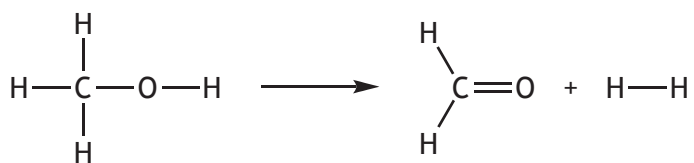

Using bond enthalpy and mean bond enthalpy values from the data booklet, calculate the enthalpy change, in kJ mol^{-1} , for the reaction.

2

[Turn over



9. A group of students carried out an investigation into the energy changes that take place when metal hydroxides dissolve in water.

The following apparatus was used as a simple calorimeter to determine the change in temperature.

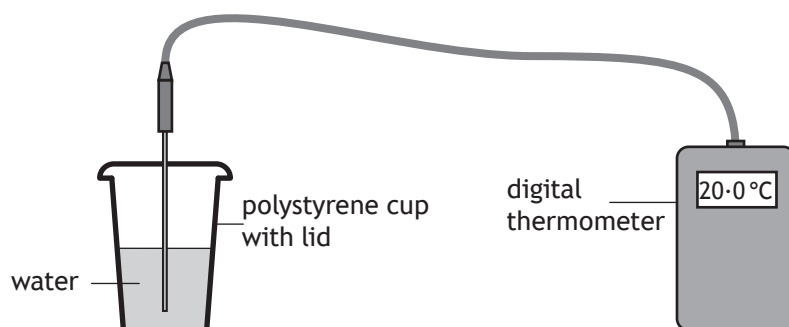

The experiment was carried out as follows.

Step 1: 100 cm³ of deionised water was added to the cup.

Step 2: The stop-clock was started, the water stirred continuously and the temperature recorded every 20 seconds.

Step 3: After 60 seconds, an accurately weighed mass of the metal hydroxide was added to the water and the temperature recorded every 20 seconds.

Graph 1 shows the group's results for lithium hydroxide.

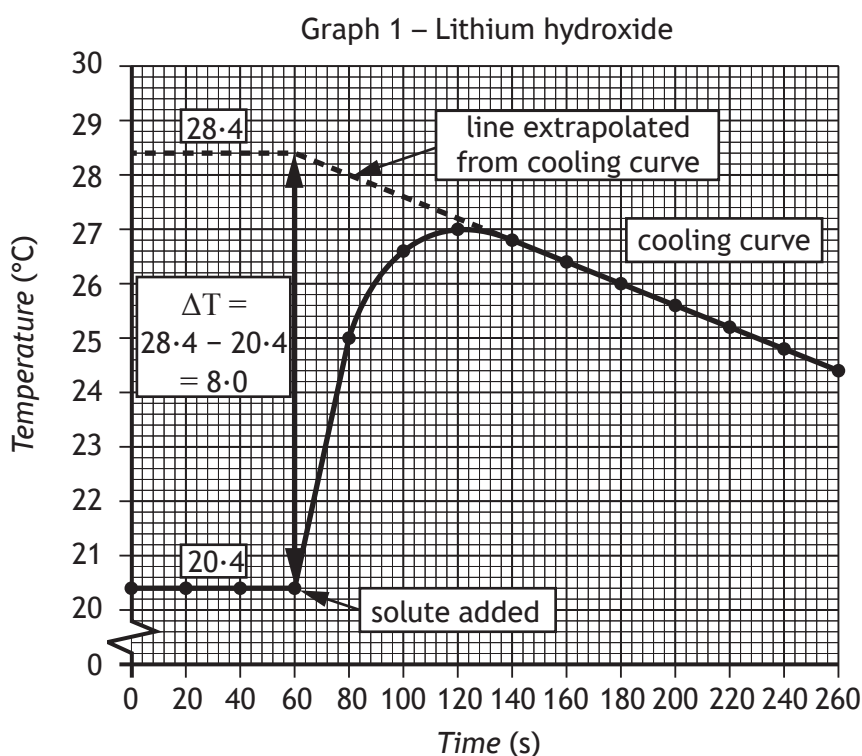

The heat energy transferred to the water can be calculated as shown.

$$\begin{aligned}
 E_h &= cm\Delta T \\
 &= 4.18 \times 0.10 \times 8.0 \\
 &= 3.3 \text{ kJ}
 \end{aligned}$$



* X 7 1 3 7 6 0 1 2 6 *

9. (continued)

MARKS
DO NOT
WRITE IN
THIS
MARGIN

- (a) The experiment was repeated using sodium hydroxide.
Graph 2 shows the results of this experiment.

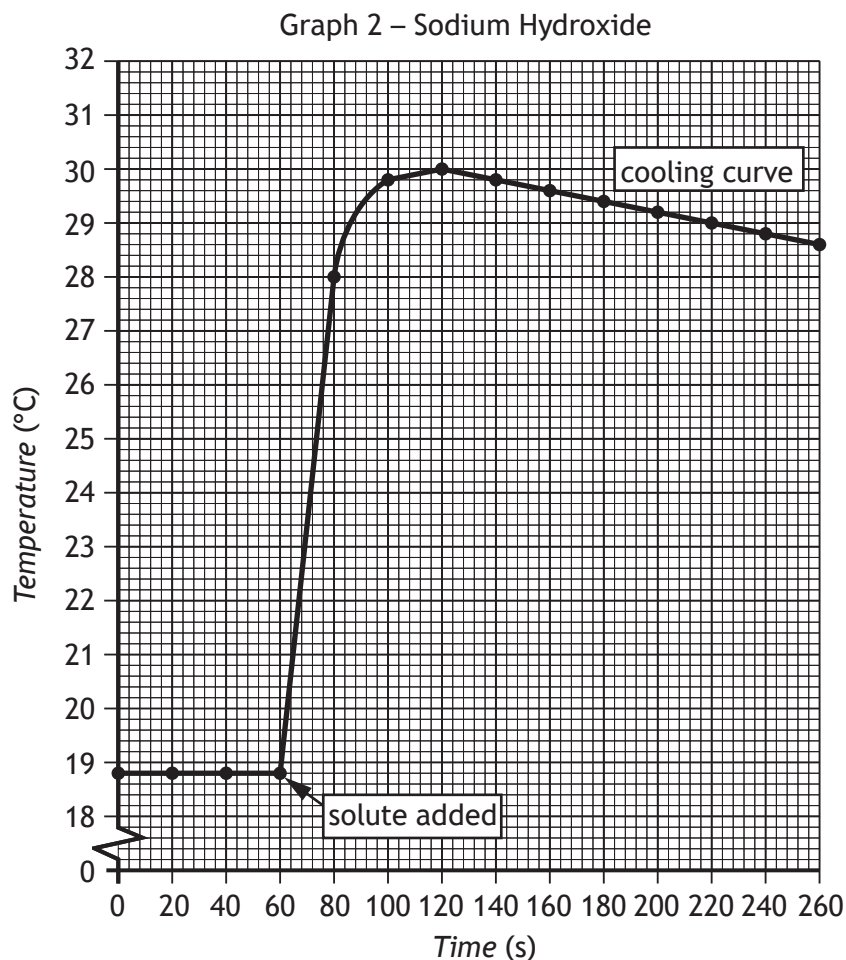

- (i) Using Graph 2 calculate the heat energy transferred to the water, in kJ, when the sodium hydroxide dissolved. 2

- (ii) Suggest why the experiment was carried out in a polystyrene cup with a lid. 1



9. (a) (continued)

(iii) In another experiment the students found that 5.61 g of potassium hydroxide (KOH) released 5.25 kJ of heat energy on dissolving.

Use this information to calculate the energy released, in kJ mol^{-1} , when one mole of potassium hydroxide dissolves in water.

1

(b) Calcium hydroxide solution can be formed by adding calcium metal to excess water.

Solid calcium hydroxide would form if the exact molar ratio of calcium to water is used. The equation for the reaction is

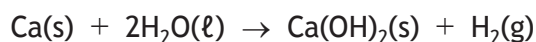

Calculate the enthalpy change, in kJ mol^{-1} , for the reaction above by using the data shown below.

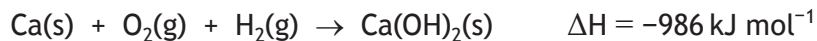

2



* X 7 1 3 7 6 0 1 2 8 *

10. The chemical industry creates an immense variety of products which impact on virtually every aspect of our lives. Industrial scientists, including chemical engineers, production chemists and environmental chemists, carry out different roles to maximise the efficiency of industrial processes.

Using your knowledge of chemistry, comment on what industrial scientists can do to maximise profit from industrial processes and minimise impact on the environment.

3



* X 7 1 3 7 6 0 1 2 9 *

11. Soft drinks contain a variety of sugars. A student investigated the sugar content of a soft drink.

- (a) The density of the soft drink can be used to estimate its total sugar concentration. Solutions of different sugars, with the same concentration, have similar densities.

The first experiment was to determine the total sugar concentration of the soft drink by comparing the density of the drink with the density of standard sucrose solutions.

- (i) This firstly involved producing standard sucrose solutions of different concentrations.

The standard sucrose solutions were made up in volumetric flasks.

Draw a diagram of a volumetric flask.

1

- (ii) The density of each standard sucrose solution was then determined. In order to determine the density of each solution, the student accurately measured the mass of 10.0 cm^3 of each sucrose solution.

Describe **fully** a method that the student could have used to accurately measure the mass of 10.0 cm^3 of each sucrose solution.

2



* X 7 1 3 7 6 0 1 3 0 *

11. (a) (continued)

(iii) The results that the student obtained for the density of the standard solutions of sucrose are shown in the table.

<i>% Concentration of sucrose solution</i>	<i>Density of sucrose solution (g cm⁻³)</i>
0.0	1.00
5.0	1.10
10.0	1.19
15.0	1.31
20.0	1.41

Draw a line graph using the student's results.

2

(Additional graph paper, if required, can be found on Page 38.)

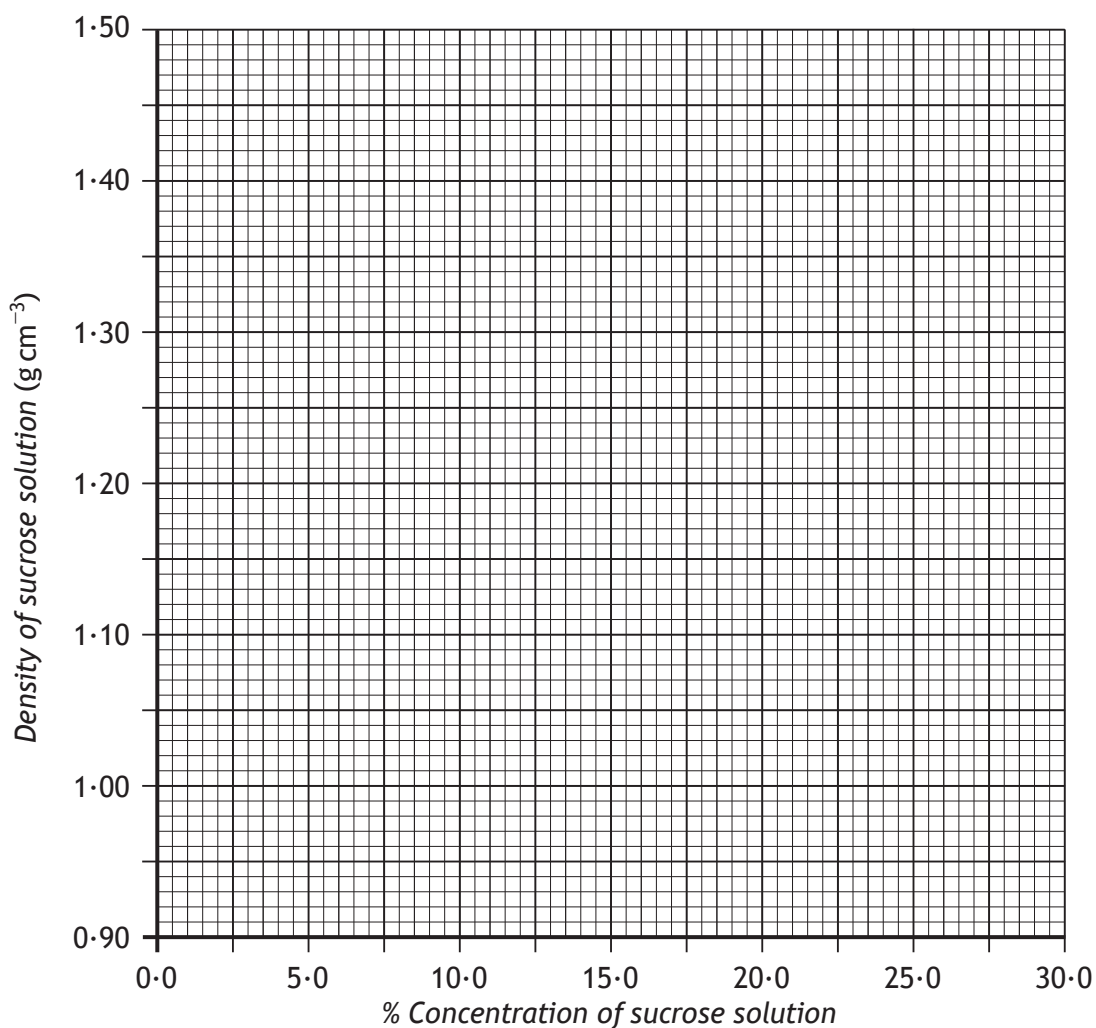

11. (a) (continued)

- (iv) The student used the line graph to obtain the relationship between the concentration of sugars in solution and the density of the solution.

This equation shows the relationship.

$$\text{density of sugar in g cm}^{-3} = (0.0204 \times \% \text{ concentration of sugars in solution}) + 1.00$$

The student then determined the density of a soft drink. In order to ensure that the drink was flat, all the gas had been allowed to escape.

- (A) Suggest a reason why the soft drink needed to be flat before its density was determined. 1

- (B) The soft drink tested had a density of 1.07 g cm^{-3} .

Using the equation, calculate the % concentration of sugars present in the soft drink. 1

- (v) A different soft drink is found to contain 10.6 grams of sugar in 100 cm^3 .

Calculate the total mass of sugar present, in grams, in a 330 cm^3 can of this soft drink. 1

- (b) The second experiment in the investigation was to determine the concentration of specific types of sugar called reducing sugars. This was carried out by titration with Fehling's solution.

- (i) Reducing sugars contain an aldehyde functional group.

Draw this functional group. 1



11. (b) (continued)

- (ii) The overall reaction that occurs with Fehling's solution and a reducing sugar is shown.

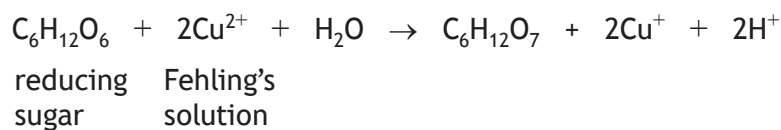

Write the ion-electron equation for the oxidation reaction. 1

- (iii) State the colour change that would be observed when reducing sugars are reacted with Fehling's solution. 1

- (iv) For the titrations, the student diluted the soft drink to improve the accuracy of results.

25.0 cm³ samples of the diluted soft drink were titrated with Fehling's solution which had a Cu²⁺ concentration of 0.0250 mol l⁻¹.

The average volume of Fehling's solution used in the titrations was 19.8 cm³.

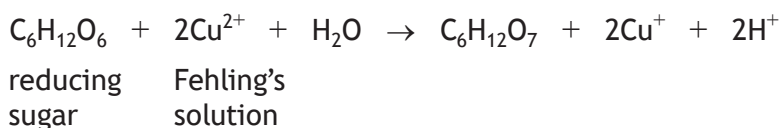

Calculate the concentration, in mol l⁻¹, of reducing sugars present in the diluted sample of the soft drink. 3



12. (a) The table shows the boiling points and structures of some isomers with molecular formula $C_6H_{12}O_2$.

DO NOT
WRITE IN
THIS
MARGIN

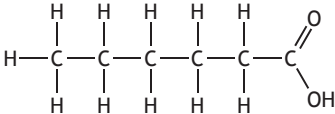
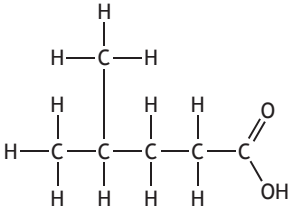
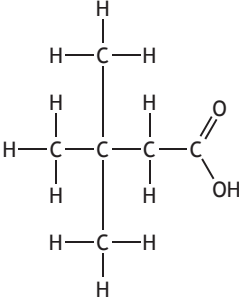
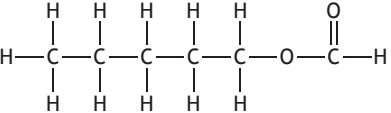
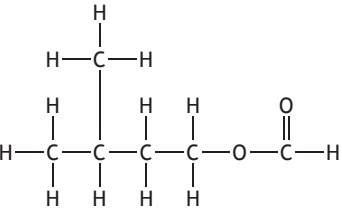
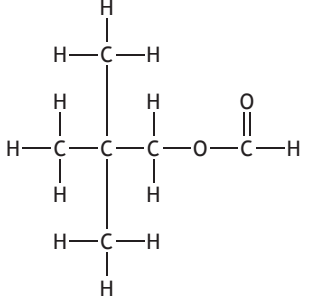
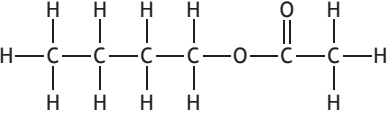
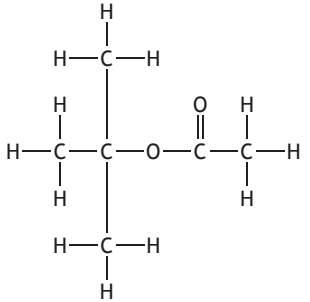
Isomer	Structure	Boiling point ($^{\circ}C$)
1		205
2		201
3		187
4		132
5		125
6		119
7		126
8		98



* X 7 1 3 7 6 0 1 3 4 *

12. (a) (continued)

- (i) Name the intermolecular force which accounts for the higher boiling points of isomers 1, 2 and 3. 1
- (ii) Using the information in the table, describe **two** ways in which differences in structure affect the boiling points of isomeric esters 4–8. 2
- (iii) Predict the boiling point, in °C, for the isomer shown below. 1

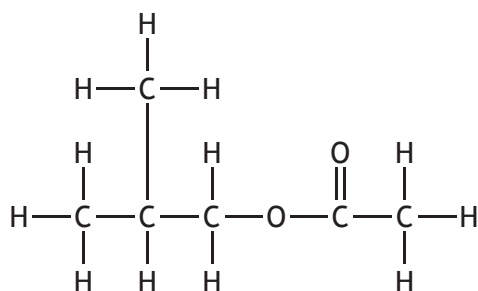

[Turn over



12. (continued)

- (b) Carbon-13 NMR spectroscopy is a technique that can be used in chemistry to determine the structure of organic molecules such as esters.

In a carbon-13 NMR spectrum, a carbon atom in a molecule is identified by its **chemical shift**. This value depends on the other atoms bonded to the carbon atom, which is known as the “chemical environment” of the carbon-13 atom.

Carbon-13 chemical shift values are shown in the table below.

The carbon-13 atom in each chemical environment has been circled.

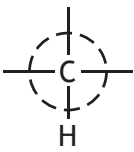
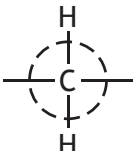
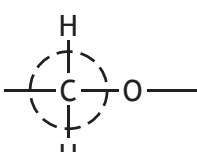
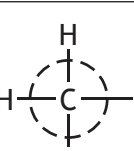
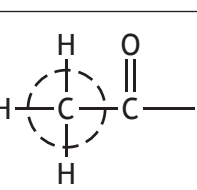
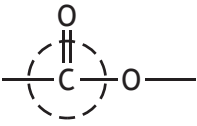
<i>Chemical environment</i>	<i>Chemical shift (ppm)</i>
	25–35
	16–25
	50–90
	10–15
	20–50
	170–185

The **number** of peaks in a carbon-13 NMR spectrum corresponds to the number of carbon atoms in different chemical environments within the molecule.

The **position** of a peak (the chemical shift) indicates the type of carbon atom.



* X 7 1 3 7 6 0 1 3 6 *

ADDITIONAL DIAGRAM FOR USE IN QUESTION 1 (b) (i)

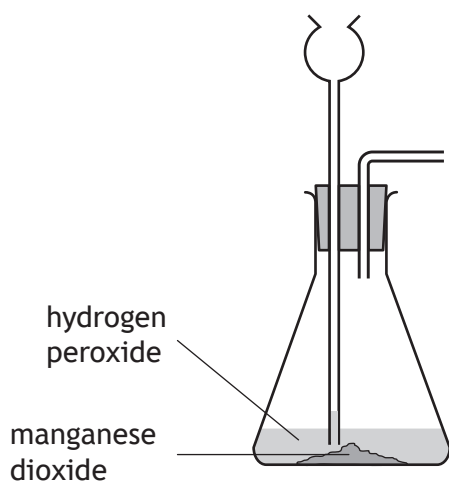

ADDITIONAL GRAPH PAPER FOR QUESTION 11 (a) (iii)

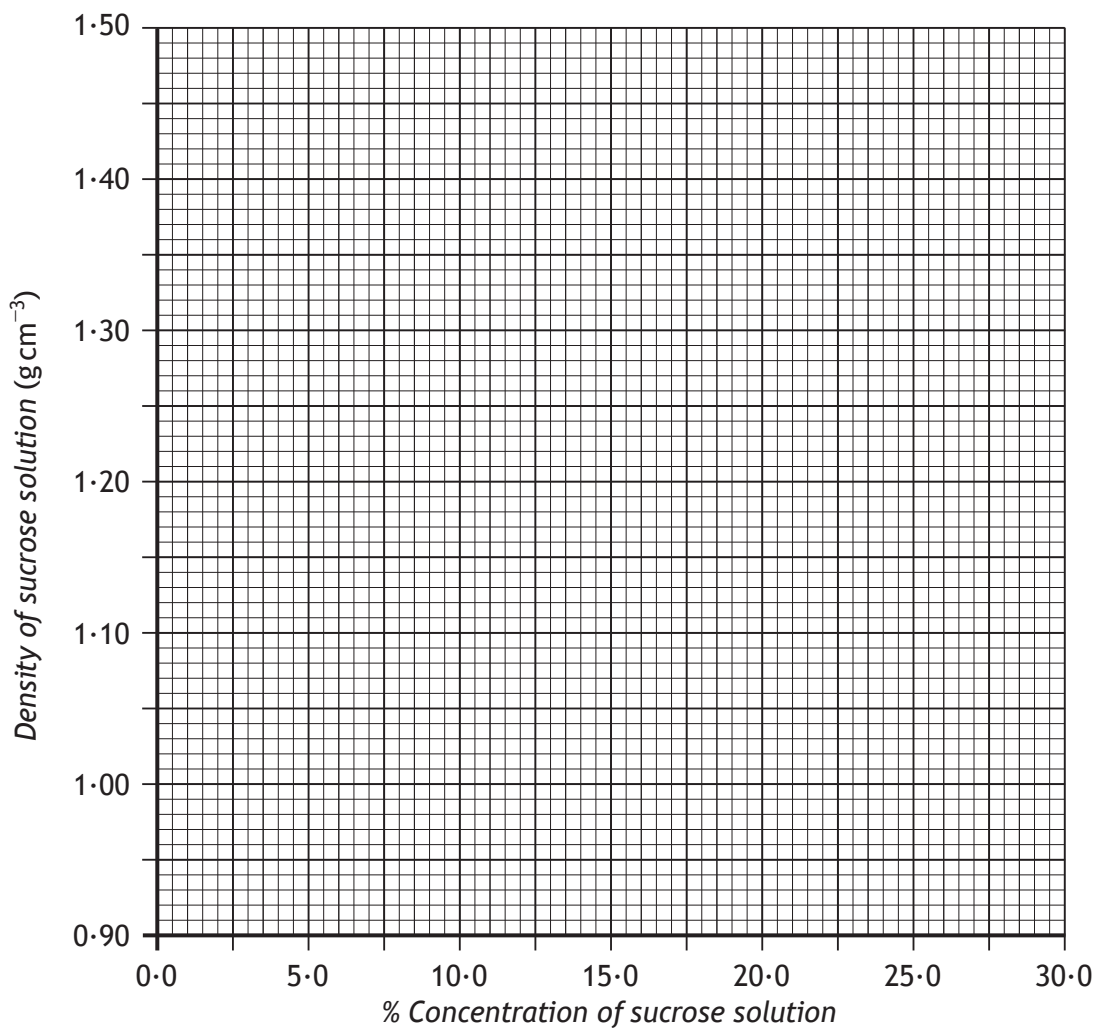

MARKS

DO NOT
WRITE IN
THIS
MARGIN

ADDITIONAL SPACE FOR ANSWERS AND ROUGH WORK



* X 7 1 3 7 6 0 1 3 9 *

MARKS

DO NOT
WRITE IN
THIS
MARGIN

ADDITIONAL SPACE FOR ANSWERS AND ROUGH WORK



* X 7 1 3 7 6 0 1 4 0 *

ACKNOWLEDGEMENT

Section 2 Question 7 - sima/shutterstock.com



* X 7 1 3 7 6 0 1 4 1 *