



National  
Qualifications  
2016

---

# **2016 Engineering Science**

## **Higher**

### **Finalised Marking Instructions**

© Scottish Qualifications Authority 2016

The information in this publication may be reproduced to support SQA qualifications only on a non-commercial basis. If it is to be used for any other purposes written permission must be obtained from SQA's NQ Assessment team.

Where the publication includes materials from sources other than SQA (secondary copyright), this material should only be reproduced for the purposes of examination or assessment. If it needs to be reproduced for any other purpose it is the centre's responsibility to obtain the necessary copyright clearance. SQA's NQ Assessment team may be able to direct you to the secondary sources.

These Marking Instructions have been prepared by Examination Teams for use by SQA Appointed Markers when marking External Course Assessments. This publication must not be reproduced for commercial or trade purposes.



## General Marking Principles for Higher Engineering Science

*This information is provided to help you understand the general principles you must apply when marking candidate responses to questions in this Paper. These principles must be read in conjunction with the detailed marking instructions, which identify the key features required in candidate responses.*

- (a) Marks for each candidate response must always be assigned in line with these General Marking Principles and the Detailed Marking Instructions for this assessment.
- (b) Marking should always be positive, ie marks should be awarded for what is correct and not deducted for errors or omissions.
- (c) If a specific candidate response does not seem to be covered by either the principles or detailed Marking Instructions, and you are uncertain how to assess it, you must seek guidance from your Team Leader.
- (d) Where a candidate makes an error at an early stage in a multi-stage calculation, credit should normally be given for correct follow-on working in subsequent stages, unless the error significantly reduces the complexity of the remaining stages. The same principle should be applied in questions which require several stages of non-mathematical reasoning.
- (e) All units of measurement will be presented in a consistent way, using negative indices where required (eg  $\text{ms}^{-1}$ ). Candidates may respond using this format, or solidus format (m/s), or words (metres per second), or any combination of these (eg metres/second).
- (f) Answers to numerical questions should normally be rounded to an appropriate number of significant figures. However, the mark can be awarded for answers which have up to two figures more or one figure less than the expected answer.
- (g) Unless a numerical question specifically requires evidence of working to be shown, full marks should be awarded for a correct final answer (including unit) on its own.
- (h) A mark can be awarded when a candidate writes down the relevant formula **and** substitutes correct values into the formula. No mark should be awarded for simply writing down a formula, without any values.
- (i) Credit should be given where a labelled diagram or sketch conveys clearly and correctly the response required by the question.
- (j) Marks should be awarded regardless of spelling as long as the meaning is unambiguous.
- (k) Candidates may answer programming questions in any appropriate programming language. Marks should be awarded, regardless of minor syntax errors, as long as the intention of the coding is clear.
- (l) Where a question asks the candidate to “explain”, marks should only be awarded where the candidate goes beyond a description, for example by giving a reason, or relating cause to effect, or providing a relationship between two aspects.
- (m) Where separate space is provided for rough working and a final answer, marks should normally only be awarded for the final answer, and all rough working ignored.

## Marking Instructions for each question

### Section 1

Question		Expected Answer(s)	Max Mark	Additional Guidance
1.	(a)	$I = P/V = 3/6 = 0.5A$  $R = V/I \quad 6/0.5 = 12 \Omega$  Alternative working $P=V^2/R$	2	1 for intermediate value  1 answer and unit  Correct answer and unit with no working - Full marks  Correct answer with no unit or working - no marks
	(b)	$R_t = 12 + 0.5 = 12.5 \Omega$  $I = V/R = 6/ 12.5 = 0.48A$	2	1 for intermediate value  1 answer and unit  If $I=P/V$ (6/3) is used no marks
	(c)	$P= I^2R = 0.48^2 \times 0.5 = 0.115 W$ 1 answer and unit	1	

Question	Expected Answer(s)	Max Mark	Additional Guidance
2.	<p>UCS FOR Aluminium alloy= <math>300\text{Nmm}^{-2}</math> (data book)</p> <p>Safe stress = UCS <math>\div</math> FOS  = <math>300 \div 4</math>  = <math>75\text{Nmm}^{-2}</math></p> <p>Area= Force <math>\div</math> Stress  = <math>100\,000\text{ N} \div 75\text{Nmm}^{-2}</math>  = <math>1333\text{mm}^2</math></p> <p><math>D = \sqrt{4a \div \pi}</math>  = <math>\sqrt{4 \times 1333 \div 3.14}</math>  = <math>\sqrt{1698}</math>  = <math>41.2\text{mm}</math></p>	4	<p>1 mark <math>300\text{Nmm}^{-2}</math></p> <p>1 mark <math>75\text{Nmm}^{-2}</math></p> <p>1 mark <math>1333\text{mm}^2</math></p> <p>1 mark <math>41.2\text{mm}</math> (Answer with unit)</p> <p>Candidates should be given credit when using Ultimate Stress and Ultimate Load.</p>

Question		Expected Answer(s)	Max Mark	Additional Guidance																																																						
3.	(a)	$\overline{(A \cdot \overline{B})} + C = Z$ <p>Alternative answer</p> $\overline{(A \cdot \overline{B} \cdot \overline{C})} + \overline{(A \cdot \overline{B} \cdot C)} + \overline{(A \cdot B \cdot \overline{C})} + \overline{(A \cdot B \cdot C)} + (A \cdot \overline{B} \cdot C) + (A \cdot B \cdot \overline{C}) + (A \cdot B \cdot C) = Z$	3	1 mark (A.B) 1 mark for NAND 1 mark +C  Alternative answer  Candidate answers from the truth table marks are awarded as follows  <b>1 out of 2 marks</b> for 4 out of 7 terms <b>2 out of 2 marks</b> for 7 out of 7 terms <b>1 mark</b> for OR operators Max 3 marks																																																						
	(b)	<table border="1"> <thead> <tr> <th>A</th> <th>B</th> <th>C</th> <th>D</th> <th>E</th> <th>Z</th> </tr> </thead> <tbody> <tr><td>0</td><td>0</td><td>0</td><td>1</td><td>1</td><td>1</td></tr> <tr><td>0</td><td>0</td><td>1</td><td>1</td><td>1</td><td>1</td></tr> <tr><td>0</td><td>1</td><td>0</td><td>0</td><td>1</td><td>1</td></tr> <tr><td>0</td><td>1</td><td>1</td><td>0</td><td>1</td><td>1</td></tr> <tr><td>1</td><td>0</td><td>0</td><td>1</td><td>0</td><td>0</td></tr> <tr><td>1</td><td>0</td><td>1</td><td>1</td><td>0</td><td>1</td></tr> <tr><td>1</td><td>1</td><td>0</td><td>0</td><td>1</td><td>1</td></tr> <tr><td>1</td><td>1</td><td>1</td><td>0</td><td>1</td><td>1</td></tr> </tbody> </table>	A	B	C	D	E	Z	0	0	0	1	1	1	0	0	1	1	1	1	0	1	0	0	1	1	0	1	1	0	1	1	1	0	0	1	0	0	1	0	1	1	0	1	1	1	0	0	1	1	1	1	1	0	1	1	3	1 mark D 1 mark E 1 mark Z
A	B	C	D	E	Z																																																					
0	0	0	1	1	1																																																					
0	0	1	1	1	1																																																					
0	1	0	0	1	1																																																					
0	1	1	0	1	1																																																					
1	0	0	1	0	0																																																					
1	0	1	1	0	1																																																					
1	1	0	0	1	1																																																					
1	1	1	0	1	1																																																					

Question		Expected Answer(s)	Max Mark	Additional Guidance
4.		$\Sigma M=0$ $(500 \times 1.25) + (140 \times 2) = R_b \times 2.5$ $R_b = 362N$	3	1 mark for calculating UDL(500N)  1 mark for substitutions  1 mark for calculating Rb with unit

Question		Expected Answer(s)	Max Mark	Additional Guidance
5.		<p>It supports the weight of the bike while allowing the wheel to rotate.</p> <p>Reduces contact surface area and therefore energy loss.</p> <p>Reduces contact surface area so reduces friction.</p> <p>Reduces friction and therefore saves wear on the shaft.</p> <p>Replace the worn bearing instead of the parent part.</p>	2	<p>1 mark for any two relevant cause and effect responses</p> <p>'Reduces friction' without explanation not accepted</p>

Section 2

Question		Expected Answer(s)	Max Mark	Additional Guidance
6.	(a)	<p>Any of the following statements will receive 1 mark up to a maximum of 8 marks.</p> <ol style="list-style-type: none"> <li>1. Pressing either valve A or B will actuate valve C.</li> <li>2. When C is actuated cylinder 1 instrokes and actuates D.</li> <li>3. D will actuate E which will cause cylinder 2 to instroke.</li> <li>4. The system will remain in this state until F or G is actuated.</li> <li>5. When F or G is actuated E will change state and outstroke cylinder 2.</li> <li>6. When F or G is actuated H will change state causing main air to reach J.</li> <li>7. When cylinder 2 actuates J a pilot signal actuates C.</li> <li>8. When C is actuated cylinder 1 outstrokes and actuates valve K causing H to actuate.</li> <li>9. Stating or implying that H cuts off the supply of air to J or C.</li> <li>10. Valve H prevents two pilot signals trying to acutate C at the same time.</li> </ol>	8	Appropriate terminology must be evident throughout.
	(b)	<p>Valves A, B, F and G would be replaced by electronic switches.</p> <p>Solenoid actuators would be required on C and E.</p> <p>Microcontroller/Programmable circuit to control the valves.</p>	2	1 mark for identifying the need for solenoid actuators (or valves). 1 mark for identifying the need for electronic switches at inputs.
	(c)	<p>Skills statements such as:</p> <ul style="list-style-type: none"> <li>• Use nodal analysis to determine the forces inside the members of the structure.</li> <li>• Use stress calculations to determine appropriate dimensions for each member.</li> <li>• Performing virtual stress analysis on computer modelled designs.</li> <li>• Perform force calculations to determine the required size of cylinders and air pressures.</li> <li>• Use a sum of moments calculation to determine the reaction forces at the banks.</li> <li>• Designing of a pneumatic circuit.</li> </ul> <p>Knowledge statements such as:</p> <ul style="list-style-type: none"> <li>• Use knowledge of material properties to select those most appropriate.</li> <li>• Knowledge of pneumatic components.</li> </ul>	3	<p>1 mark for each valid point relevant to the context.</p> <p>No marks awarded when describing gears and drive systems as this is not in context of question.</p> <p>If candidate refers to it in the machinery involved in the construction; then marks can be awarded.</p>

Question		Expected Answer(s)	Max Mark	Additional Guidance
	(d)	<p>Civil engineer would assess the area around the canal to determine the most suitable location or whether the bank would need to be strengthened.</p> <p>Project engineer will be required to time manage, cost analyse, liaise with clients and engineers.</p>	2	<p>1 mark for each valid statement relating either to particular branches of engineering. Any branch of engineer is acceptable so long as relevant specialist role statements are made.</p> <p>If candidate gives two engineers, marks can only be awarded to one engineer (which ever has greater number of marks).</p>

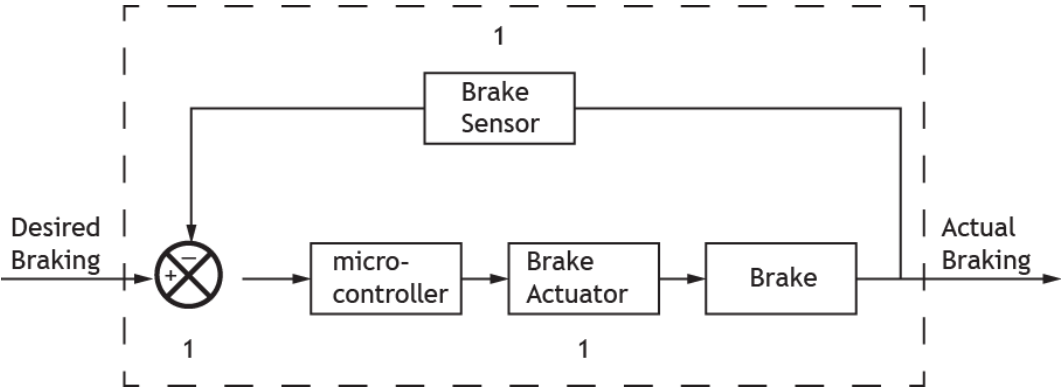

Question	Expected Answer(s)	Max Mark	Additional Guidance
(b)	 <p data-bbox="367 728 1101 828"> 1 mark for error detector (must show negative error)  1 mark for feedback (Brake Sensor)  1 mark for Brake Actuator or Driver/Transistor/MOSFET </p>	3	
7.	(c) (i) Electrical/Electronic Specialist Knowledge: Understand how microcontrollers function Understand interfacing Function of a relay Programming knowledge. Energy audits.	2	1 mark for any relevant information up to a max of 2 marks.
	(ii) Electrical/Electronic Specialist skill: Plan programmes Design interfaces Test programme function Design switching circuits Write code	2	1 mark for any relevant information up to a max of 2 marks.

Question		Expected Answer(s)	Max Mark	Additional Guidance
8.	(a)	$(R.M)+(P.M) = Z$	3	1 Mark (R.M) 1 Mark (P.M) 1 Mark for OR Other acceptable answer for full marks: $M.(R+P) = Z$
	(b)		4	2 Marks for both AND gates NAND equivalents 1 Mark OR gate NAND equivalent. 1 Mark for simplification.
	(c)	$T = F \times R$ $T = (62 \times 9.8) \times (0.22/2)$ $T = 66.8\text{Nm}$	2	1 Mark for correct substitution. 1 Mark for correct answer with unit.
	(d)	<p>Material A has the highest UTS, it is the strongest and the largest Young's Modulus.</p> <p>Material B is the most brittle and has a lower UTS than A.</p> <p>Material C has the largest plastic range, is the most malleable, is the most ductile and has the lowest UTS.</p> <p>Materials A &amp; B are more elastic than C.</p>	4	One property cannot receive more than one mark.
	(e)	$\text{Strain} = 0.7/100 = 0.007$ $\text{Stress} = 202 \times 10^3 \times 0.007 = 1414$ $\text{Area} = 3.14 \times 15^2/4 = 176.6$ $\text{Load} = \text{Stress} \times \text{Area} = 1414 \times 176.6 = 249.7\text{kN}$	4	1 Mark for strain 1 Mark for stress (no unit required) 1 Mark for area (no unit required) 1 Mark for final answer with unit.

Question	Expected Answer(s)	Max Mark	Additional Guidance
(f)	<p><b>Environment effects</b></p> <p>Crude oil used to make mineral oil lubricants will become exhausted due to being finite.</p> <p>Biodegradable vegetable oil is protecting the environment.</p> <p>Reduces crop surplus as fields are used to produce natural oil yielding plants.</p> <p>Using vegetable oil increases the longevity of machines due to their superior lubricity.</p> <p>Safer than mineral oils. Non-toxic and does not damage skin tissue.</p> <p>Very high viscosity index which makes vegetable oil's viscosity stable over a wide range of temperatures.</p> <p><b>Economic Effects</b></p> <p>Biodegradable oils are becoming cheaper for specific applications.</p> <p>Reduced clean-up costs should spillages occur.</p> <p>More economically sustainable than petroleum related lubricants.</p> <p>Often grants and incentives available for the use of experimental chemicals.</p> <p>Alternative option for farmer to boost income.</p>	3	1 Mark for each correct or relevant answer.

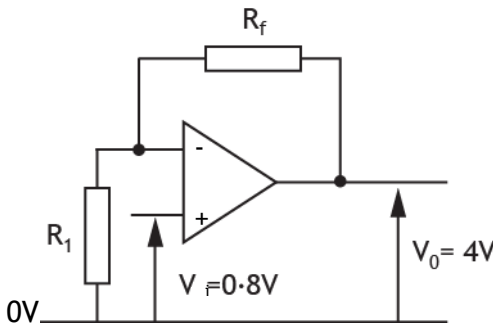
Question		Expected Answer(s)	Max Mark	Additional Guidance
9.	(a)	$V_1 = 5\text{v} - 0.8\text{v}$ $\frac{V_1}{V_2} = \frac{R_1}{R_2} \Rightarrow \frac{4.2}{0.8} = \frac{R_1}{250}$ $\Rightarrow 4.2 \times 250 = 0.8 \times R_1$ $\Rightarrow \frac{1050}{0.8} = R_1$ $\Rightarrow 1312.5 \Omega$	2	1 mark for finding 4.2v  1 mark for correct answer (or FTE) with units.  Full marks for correct answer and units with no working shown.  Acceptable answer: $1.31 \text{ k}\Omega = R_1$  Alternative solution $I = V/R$ $I = 0.8/250 = 3.2\text{mA}$  $R = V/I = 4.2/3.2 \times 10^{-3}$ $= 1.31\text{k}\Omega$
	(b) (i)	Non inverting Difference	1	
	(b) (ii)	$A_v = \frac{V_0}{V_1} = \frac{4}{0.8} = 5$	1	
	(b) (iii)	 $A_v = 1 + \frac{R_f}{R_1}$ $\frac{R_f}{R_1} = 5 - 1 = 4$	2	1 mark for diagram  Diagram must include: 0V, and Vi/Vo or 0.8V/4V  1 mark for any resistor pair in the ratio of 4:1 ie $4k(R_f) \ 1k(R_1)$  if Difference Amp is used resistors will have a 5:1 ratio

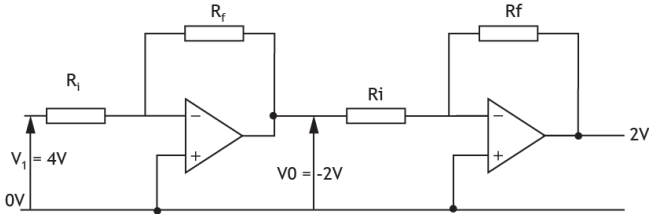
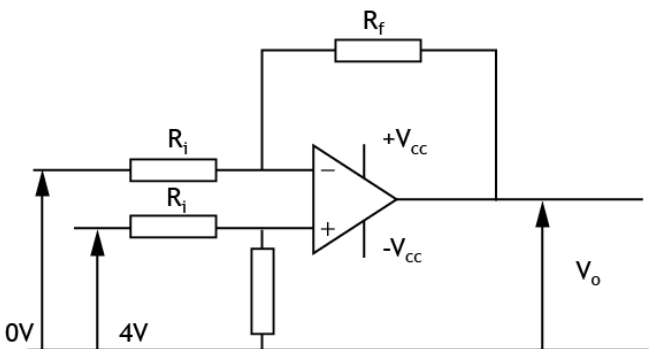
Question	Expected Answer(s)	Max Mark	Additional Guidance
9. (c)	<p>Solution using 2 inverting op amps</p> <p>Any resistor values -</p>  $V_0 = \frac{-R_f V_i}{R_i} \qquad \frac{R_f}{R_i} = -\frac{1}{2}$ $2v = \frac{-R_f 4v}{R_i}$ $0.5 = \frac{-R_f}{R_i}$ <p style="text-align: center;"><b>OR</b></p>  $V_0 = \frac{-R_f}{R_i} (V_2 - V_1)$ $2 = \frac{R_f}{R_i} (4 - 0) \Rightarrow \frac{R_f}{R_i} = \frac{1}{2}$	3	<p><b>1 mark</b> for Diagram (either inverting or difference)</p> <p>Diagram must include: Vi/Vo</p> <p>Intermediate voltage is not required.</p> <p><b>1 mark</b> for any resistor value in the ratio 1:2</p> <p><b>1 mark</b> for second op amp ratio 1:1 Any resistor values <math>V_0 = -V_i</math></p> <p style="text-align: center;"><b>OR</b></p> <p><b>1 mark</b> for correct substitution</p> <p><b>1 mark</b> for any resistor values in ratio <math>\frac{1}{2}</math> 1:2</p>

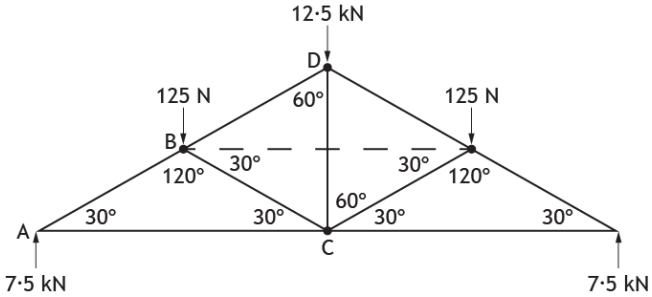
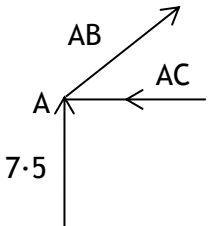
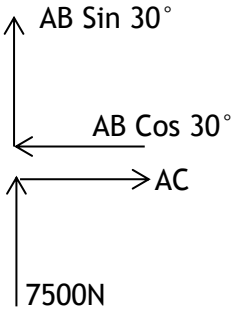
Question	Expected Answer(s)	Max Mark	Additional Guidance
(d)	$P = VI$ $= 230 \times 3 = 690W$ $P = 2\pi nT$ $= 2 \times 3.14 \times 5 \times 18.6$ $= 584W$ Efficiency ( $\eta$ ) = $\frac{\text{Power out}}{\text{Power in}} = \frac{584}{690} = 84.6\%$	3	1 mark for 690 W 1 mark for 584W 1 mark for 84.6% No units required for marks Accept 85%
(e)	 $AC = 12.9kN$ (Tie) $BC = 1.1kN$ (Strut) $BD = 13.6kN$ (Strut) $AB = 15kN$ (Strut) <b>Node A</b>  $\Sigma F_v = 0$ $AB \sin 30^\circ + 7500 = 0$ $AB \sin 30^\circ = -7500$ $AB = \frac{-7500}{\sin 30^\circ}$ $AB = \frac{7500}{0.5}$ $AB = 15kN$ (Strut)  $\Sigma F_M = 0$ $AB \cos 30^\circ = AC$ $15000 \times 0.866 = AC$ $12990.38N = AC$ $AC = (12.9kN)$ TIE	8	1 mark for magnitude AB 1 mark for nature AB 1 mark for magnitude AC 1 mark for nature AC

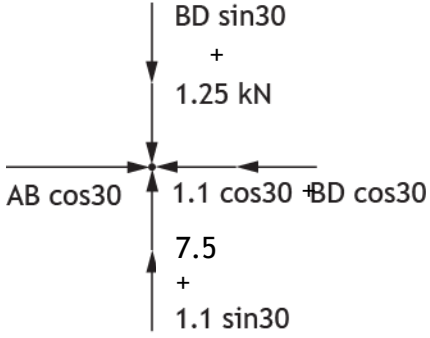
Question	Expected Answer(s)	Max Mark	Additional Guidance
(e)	<p><b>Node B</b></p>  <p><math>\Sigma F_V = 0</math>  <math>1.25 + 0.5BD = 7.5 + 0.55</math>  <math>BD = \frac{8.05 - 1.25}{0.5}</math>  <math>BD = 13.6\text{kN}</math>    Strut</p> <hr/> <p><math>\Sigma F_H = 0</math>  <math>AB \cos 30 = 1.1 \cos 30 - BD \cos 30</math>  <math>BD = \frac{11.75}{6.866} = 13.6\text{kN}</math>    Strut</p>		<p><b>Either solution for Node B acceptable</b></p> <p><b>1 mark</b> for vertical BD (BD sin30)</p> <p><b>1 mark</b> for correct substitution of <math>F_V</math></p> <p><b>1 mark</b> magnitude of BD</p> <p><b>1 mark</b> for nature of BD</p> <hr/> <p><b>1 mark</b> for horizontal BD (BD cos30)</p> <p><b>1 mark</b> for correct substitution of <math>F_H</math></p> <p><b>1 mark</b> magnitude of BD</p> <p><b>1 mark</b> for nature of BD</p>

[END OF MARKING INSTRUCTIONS]