

FOR OFFICIAL USE



National
Qualifications
2017

Mark

X723/76/01

Engineering Science

THURSDAY, 25 MAY

1:00 PM – 3:00 PM



Fill in these boxes and read what is printed below.

Full name of centre

Town

Forename(s)

Surname

Number of seat

Date of birth

Day

Month

Year

Scottish candidate number

Total marks — 90

SECTION 1 — 20 marks

Attempt ALL questions.

SECTION 2 — 70 marks

Attempt ALL questions.

Show all working and units where appropriate.

The number of significant figures expressed in a final answer should be equivalent to the least significant data value given in the question. Answers that have two more figures or one less figure than this will be accepted.

Reference may be made to the Engineering Science Higher Data Booklet.

Write your answers clearly in the spaces provided in this booklet. Additional space for answers is provided at the end of this booklet. If you use this space you must clearly identify the question number you are attempting.

Use **blue** or **black** ink.

Before leaving the examination room you must give this booklet to the Invigilator; if you do not, you may lose all the marks for this paper.



SECTION 1 — 20 marks

Attempt ALL questions

1. A specimen was tested in a materials laboratory. The results are shown in the graph below.

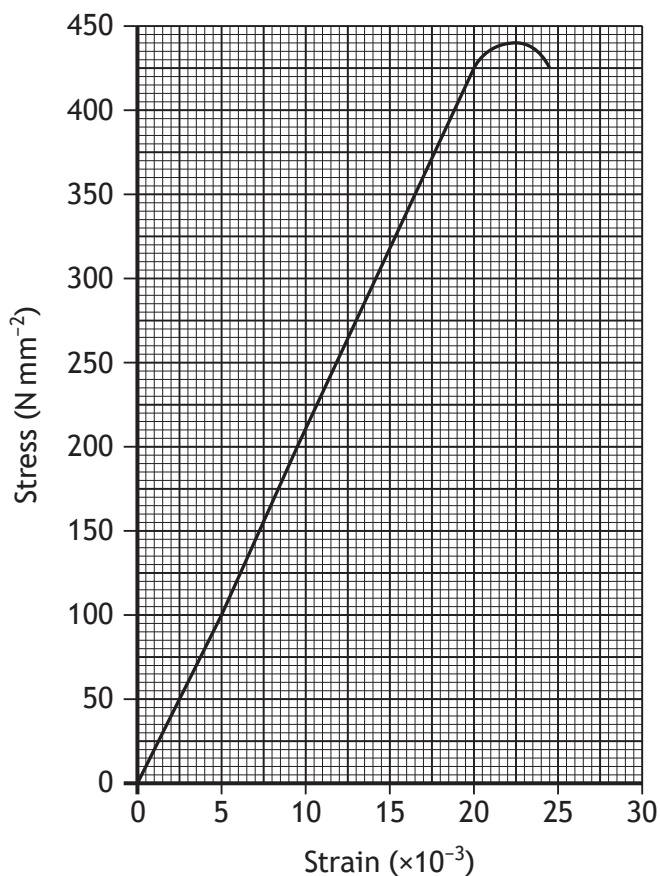

- (a) Describe the effect on the specimen of applying and then removing a stress of 125 N mm^{-2} .

1

- (b) Describe the effect on the specimen when applying a stress greater than 435 N mm^{-2} .

1

- (c) Annotate, on the graph above, the **yield point** and the **ultimate stress** of the material.

2



2. A concurrent force system is shown below.

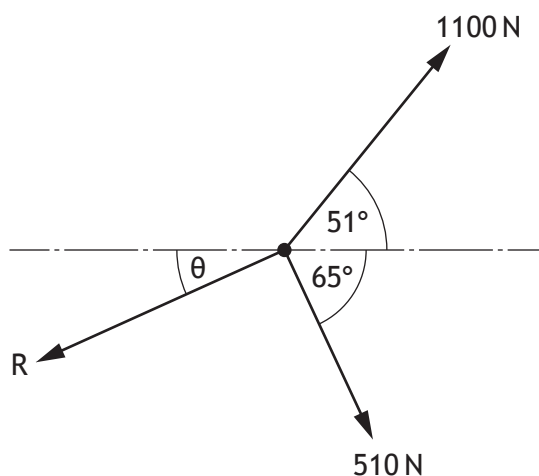

Calculate the magnitude of the force R, and the angle θ , to maintain equilibrium.

4



* X 7 2 3 7 6 0 1 0 3 *

3. A beam to be used in the construction of a new holiday cottage is being tested.

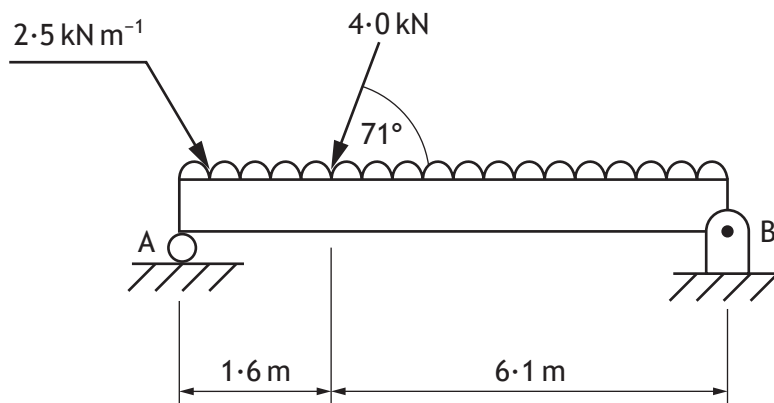

Calculate, by taking moments about B, the vertical reaction at A.

3



* X 7 2 3 7 6 0 1 0 4 *

4. A water feature in a children’s play area is designed to pump jets of water when a child blocks the light to a darkness sensor.



A circuit diagram of the system is shown below.

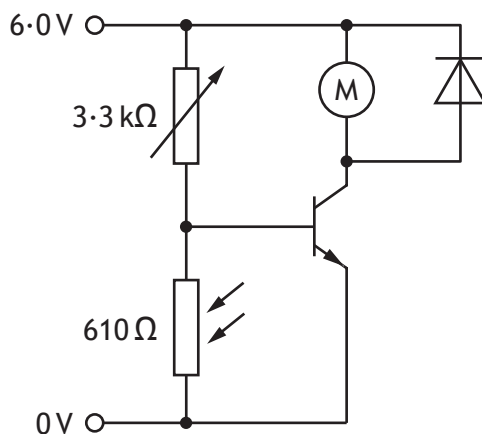

- (a) Calculate the current flowing through the LDR. ($V_{be} = 0.7V$)

1

[Turn over



* X 7 2 3 7 6 0 1 0 5 *

4. (continued)

(b) Calculate the current flowing through the variable resistor.

1

(c) Calculate the base current flowing into the transistor.

1

5. Driverless vehicles are an example of an emerging technology that may have an impact on our day-to-day lives.

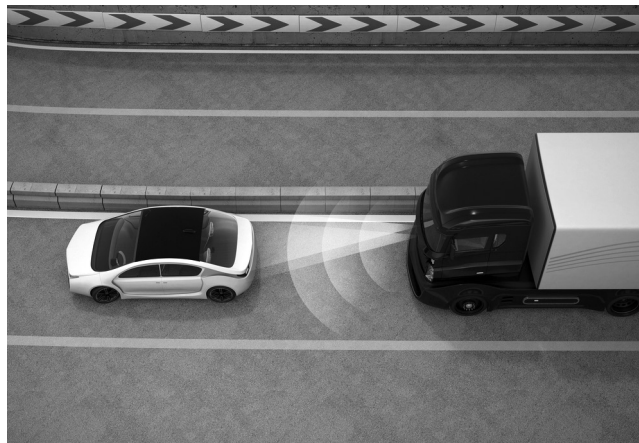

(a) Describe two **economic** impacts of driverless vehicles.

2

1 _____

2 _____



5. (continued)

(b) Describe two **social** impacts of driverless vehicles.

2

1 _____

2 _____

6. An electronic engineer is designing the control system for a food mixer. Transistors are required to drive the mixer's outputs.



(a) Describe the difference in the way that MOSFETs and bi-polar junction transistors (BJT) control their output current.

1

(b) The engineer chooses a MOSFET to drive the electric motor. Explain why a MOSFET was chosen instead of a BJT.

1

[END OF SECTION 1]



* X 7 2 3 7 6 0 1 0 7 *

SECTION 2 — 70 marks
Attempt ALL questions

7. A control room in a chemical plant monitors many different systems.



(a) Part of a logic diagram for a control system is shown below.

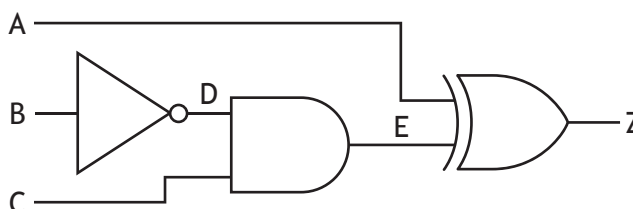

(i) Complete the Boolean equation for this logic diagram.

3

Z = _____



7. (a) (continued)

(ii) Complete the truth table for this logic diagram.

3

A	B	C	D	E	Z
0	0	0			
0	0	1			
0	1	0			
0	1	1			
1	0	0			
1	0	1			
1	1	0			
1	1	1			

(iii) Draw the NAND equivalent for the logic diagram, shown opposite.

3

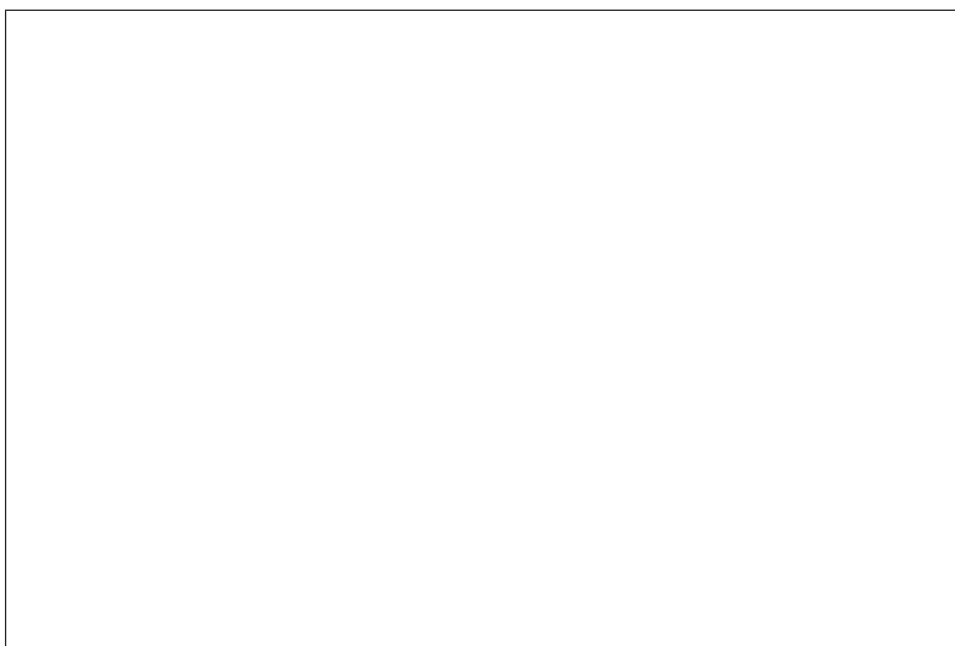

[Turn over



* X 7 2 3 7 6 0 1 0 9 *

7. (continued)

- (b) An electronic engineer is asked to design the control system for an **automatic** sprinkler for the chemical plant.

Describe one skill and one piece of knowledge the electronic engineer would use to complete this task.

2

Skill _____

Knowledge _____

- (c) An extension to the chemical plant building is proposed.

- (i) Describe a role that an environmental engineer would take in the design of the extension.

2

- (ii) Describe a positive and a negative economic impact for the **plant** by it becoming more environmentally friendly.

2

Positive impact

Negative impact



* X 7 2 3 7 6 0 1 1 0 *

8. A prototype of a delivery drone is being tested.



A proportional control system changes the speed of the rotor blades to reach the user's desired height for the drone. An altimeter is used to monitor the current height of the drone.

(a) Complete the control diagram for the drone.

3

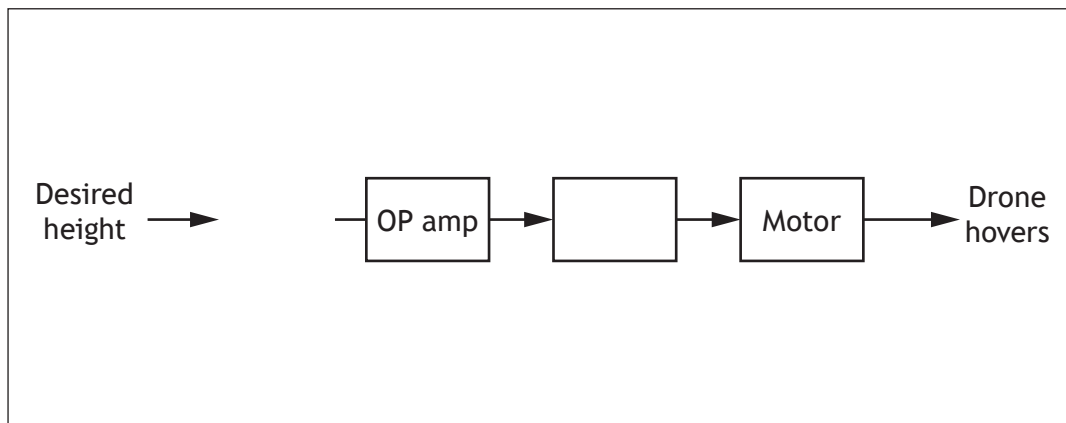

[Turn over



* X 7 2 3 7 6 0 1 1 1 *

8. (continued)

(b) Part of an electronic engineer's design for the control system for one of the drone's motors is shown below.

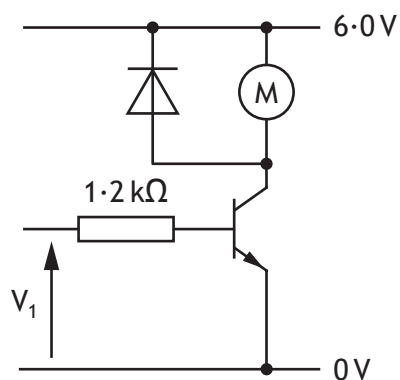

During testing it was found that the motor requires a current of 97 mA for the drone to hover. The transistor has a current gain of 210.

Calculate the value of V_1 required to make the drone hover.

3



8. (continued)

- (c) The diagram below shows another part of the control system. It combines a signal for any required changes to the motor speed (V_A) with the signal required to keep the drone hovering (V_{HOVER}).

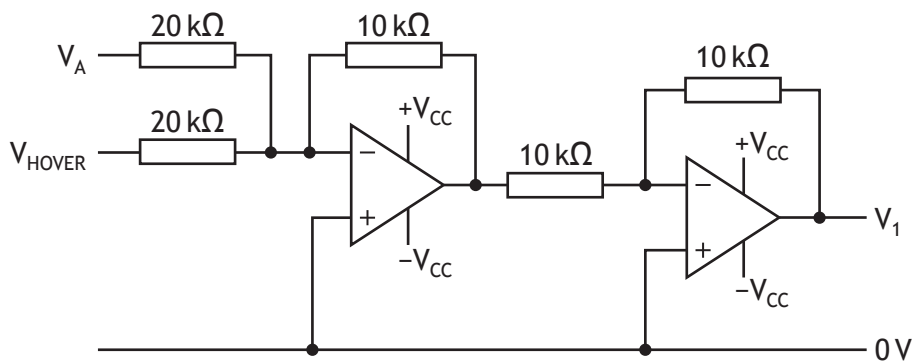

Calculate, using your answer for V_1 the value of V_{HOVER} . (Assume that V_A is 0V at this point).

2

[Turn over



8. (continued)

(d) The value of V_A is set using the circuit below. It compares the drone's current height with the operator's desired height.

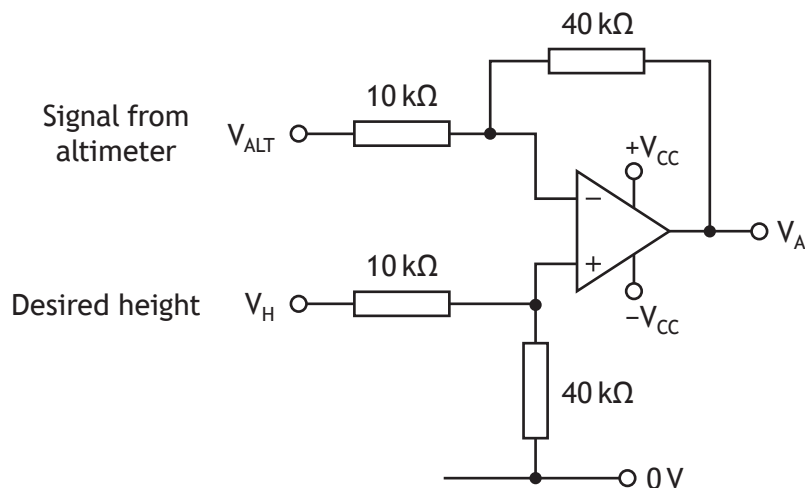

During testing V_H was changed to 3.0V and V_A was found to be 1.6V. Calculate the value of V_{ALT} for this condition.

2



8. (continued)

- (f) The diagram below shows a further sub-system which will light a series of LEDs when light levels are low

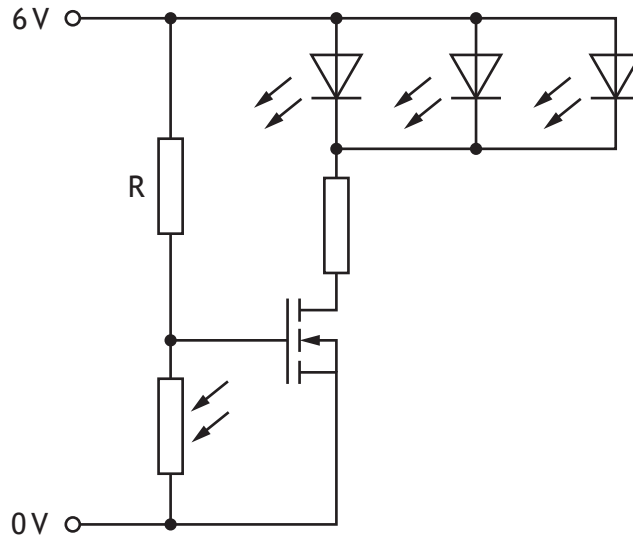

The characteristics of the LDR are shown in the graph below.

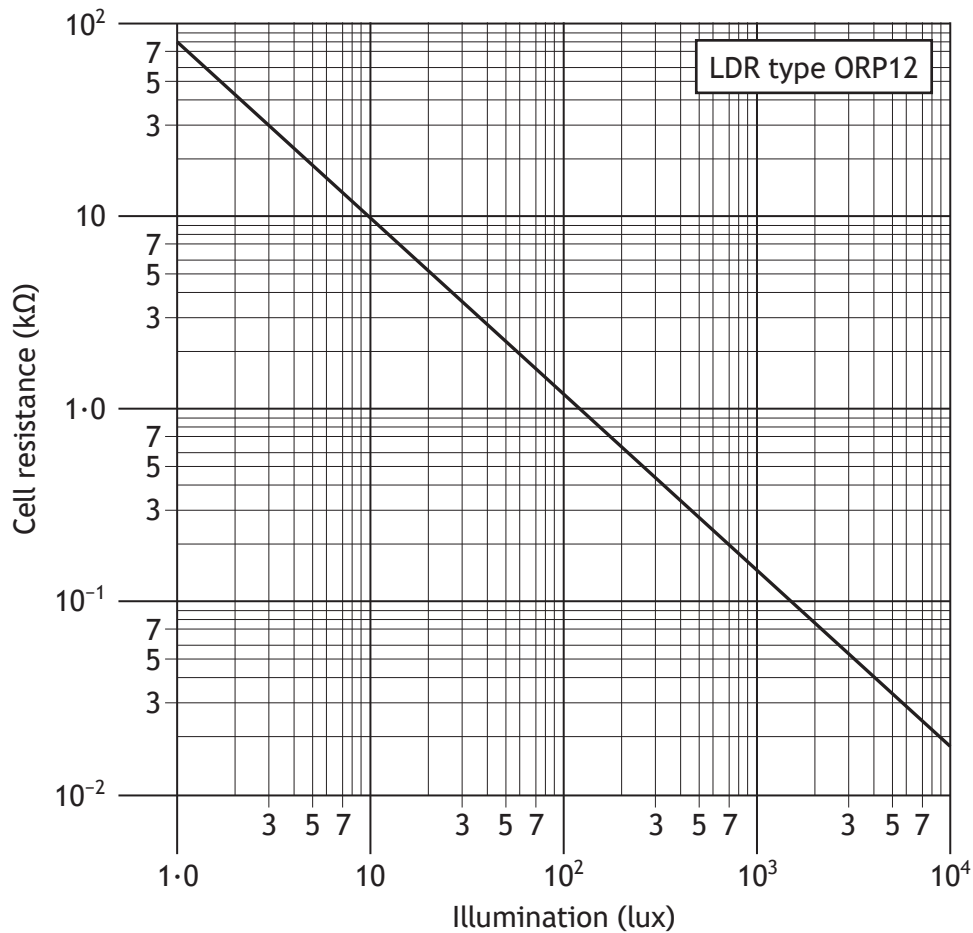

8. (f) (continued)

The LEDs must switch on when the light level drops to 200 lux. The MOSFET switches on when $V_{gs} = 3.6\text{ V}$

Calculate, with reference to the graph opposite, the required value of R.

2

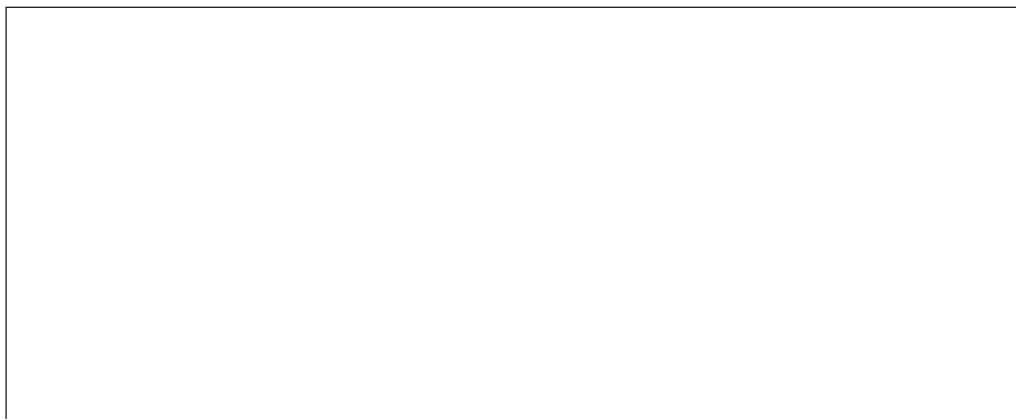

[Turn over



* X 7 2 3 7 6 0 1 1 7 *

9. A team of engineers are working together to design a new theme park ride.

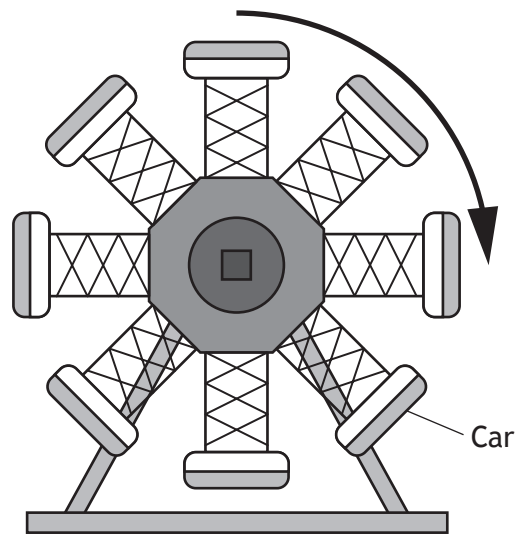

(a) Each of the ride cars is supported by mild steel beams as shown. When the ride is operating the force on a beam was found to be 900·0 N.

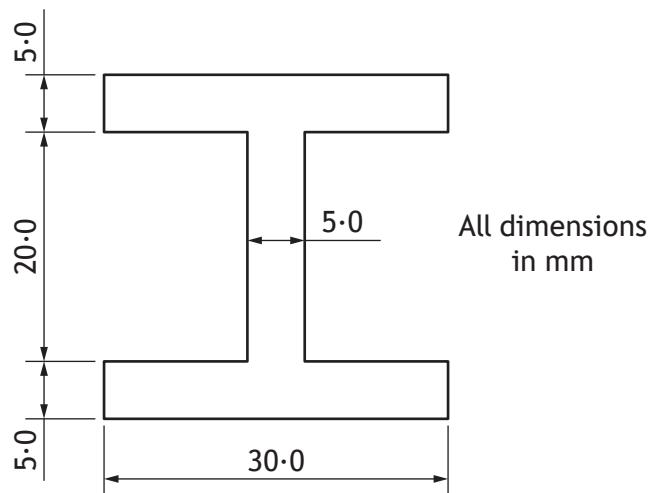

(i) Calculate the working stress of the beam.

2



9. (a) (continued)

(ii) Calculate the strain of the beam.

2

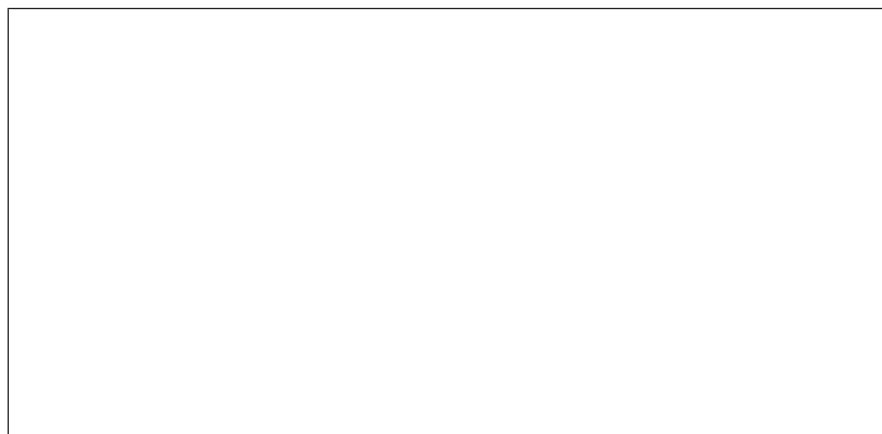

(iii) Calculate the factor of safety of the beam.

2

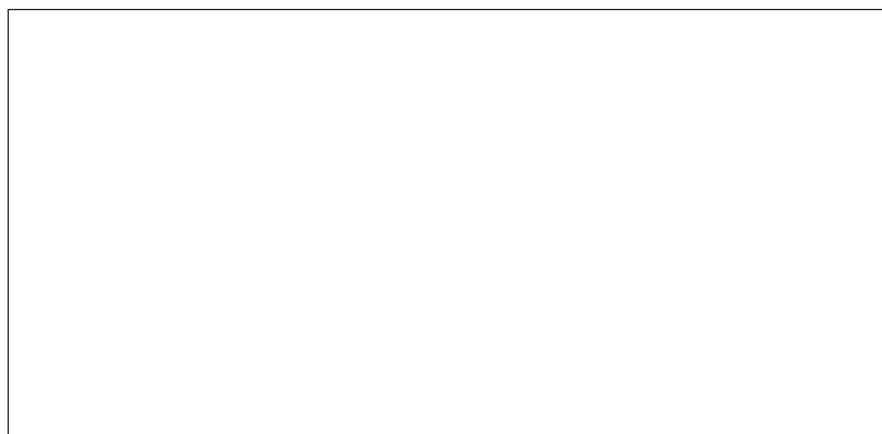

(iv) Comment on the appropriateness of the factor of safety of the beam.

1

[Turn over



* X 7 2 3 7 6 0 1 1 9 *

9. (continued)

- (b) The ride has eight cars. Each car is subjected to wind resistance of 130 N as shown in the diagram below.

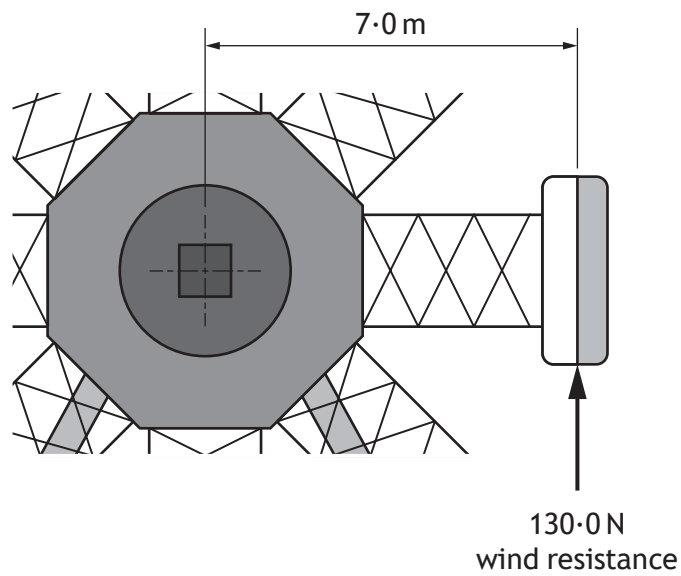

- (i) Calculate the torque produced by the drive shaft to overcome the total wind resistance.

2



9. (b) (continued)

- (ii) Each car on the ride completes 18 revolutions in 3 minutes.
Calculate the mechanical power required by the motor.

2

- (iii) Calculate the efficiency of the motor, if it is supplied with a voltage of 240 V and draws a current of 30.0 A.

2



* X 7 2 3 7 6 0 1 2 1 *

9. (continued)

(c) A microcontroller is used to control the speed of the motor.

Sketch a graph to show how pulse width modulation could be used to gradually increase the speed of a motor from rest. Your graph should include at least 6 pulses.

2

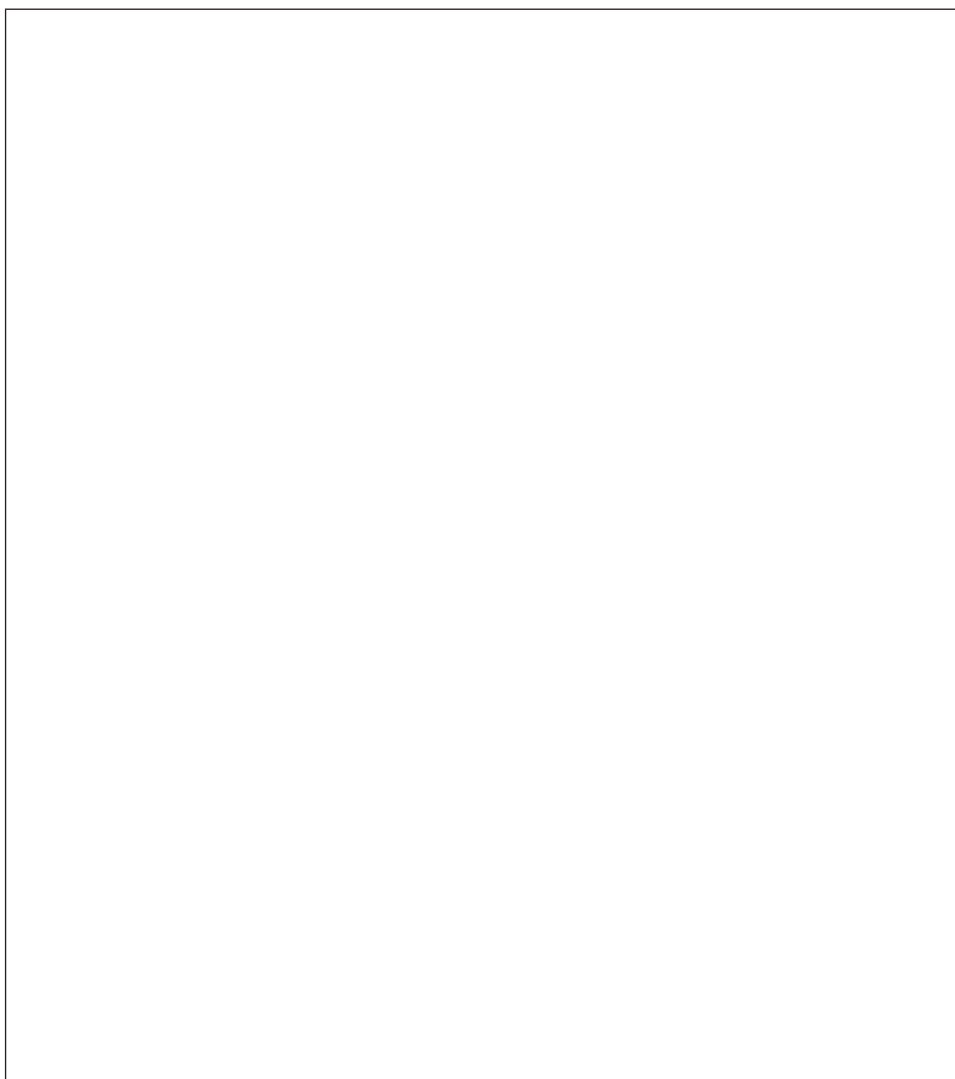

* X 7 2 3 7 6 0 1 2 2 *

9. (continued)

MARKS
DO NOT
WRITE IN
THIS
MARGIN

(d) As the ride spins, a force of 1030 N acts on a point of the structure as shown in the diagram below.

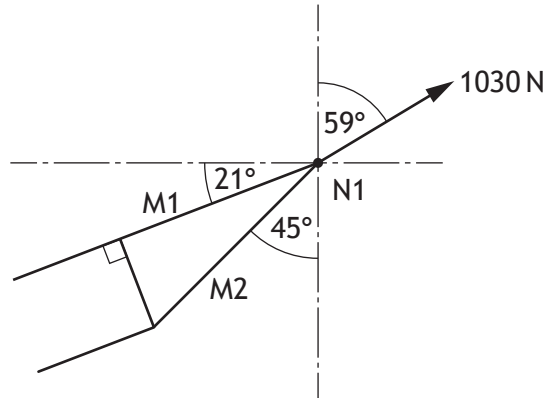

Calculate, using simultaneous equations, the magnitude of the forces in members M1 and M2.

5



10. A car manufacturer uses a pneumatic system during the production of car doors.

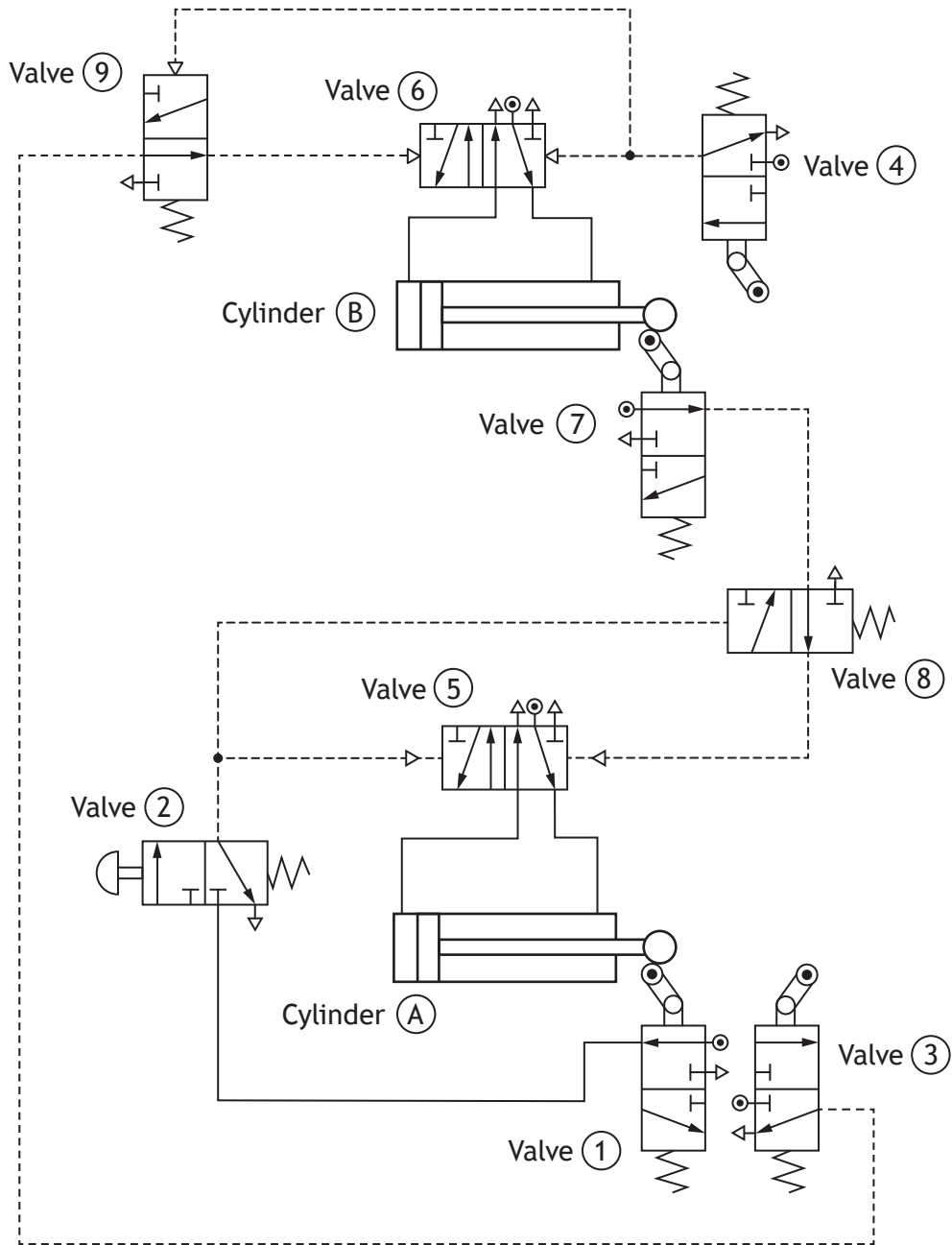

* X 7 2 3 7 6 0 1 2 4 *

10. (continued)

After the doors have been assembled, an automated system is used to ensure quality checks are made.

Part of the system operates on the following sequence:

- A motor must switch on to move doors along a conveyor;
- A light sensor detects when the door has reached the inspection point;
- A pneumatic piston outstrokes for 1 second and diverts every fourth door for inspection;
- If an operator presses the sampling switch when a door is in position it will also be diverted using the piston;
- When a door is diverted a checking light flashes on and off 6 times over 3 seconds;
- This system continually repeats.

The relevant microcontroller connections are shown in the table below.

Inputs	Pins	Outputs
	7	Pneumatic Piston
	6	Conveyor Motor
	5	Checking Light
	4	
	3	
	2	
Sampling Switch	1	
Light Sensor	0	

Light Sensor (High signal indicates a door.)



MARKS

DO NOT
WRITE IN
THIS
MARGIN

10. (continued)

(b) Draw a flowchart to show the control of the quality checks.

8

[END OF QUESTION PAPER]



* X 7 2 3 7 6 0 1 2 7 *

MARKS

DO NOT
WRITE IN
THIS
MARGIN

ADDITIONAL SPACE FOR ANSWERS



* X 7 2 3 7 6 0 1 2 8 *



MARKS

DO NOT
WRITE IN
THIS
MARGIN

ADDITIONAL SPACE FOR ANSWERS

--



* X 7 2 3 7 6 0 1 2 9 *

[BLANK PAGE]

DO NOT WRITE ON THIS PAGE



* X 7 2 3 7 6 0 1 3 0 *

[BLANK PAGE]

DO NOT WRITE ON THIS PAGE



* X 7 2 3 7 6 0 1 3 1 *

[BLANK PAGE]

DO NOT WRITE ON THIS PAGE

Acknowledgement of Copyright

Section 1 Question 4 CaseyMartin/Shutterstock.com
Section 1 Question 5 Chesky/shutterstock.com
Section 1 Question 6 Stephen VanHorn/shutterstock.com
Section 2 Question 7 Ton Snoei/shutterstock.com
Section 2 Question 8 gualtiero boffi/shutterstock.com



* X 7 2 3 7 6 0 1 3 2 *