



Higher Engineering Science Assignment

Assessment task: theme park

This document provides information for teachers and lecturers about the coursework component of this course in terms of the skills, knowledge and understanding that are assessed. It **must** be read in conjunction with the course specification.

Valid for session 2018-19 only.

The information in this publication may be reproduced in support of SQA qualifications only on a non-commercial basis. If it is reproduced, SQA must be clearly acknowledged as the source. If it is to be reproduced for any other purpose, written permission must be obtained from permissions@sqa.org.uk.

Where this publication includes material for which SQA does not own the copyright, this material must only be reproduced on a non-commercial basis for the purposes of instruction in an educational establishment. If it is to be reproduced for any other purpose, it is the user's responsibility to obtain the necessary copyright clearance from the copyright owner. The acknowledgements page lists the owners of copyright items that are not owned by SQA.

This edition: January 2019 (version 1.0)

© Scottish Qualifications Authority 2019

Contents

Introduction	1
Instructions for teachers and lecturers	2
Instructions for candidates	6
Worksheets	25

Introduction

This document contains instructions for teachers and lecturers, and instructions for candidates for the Higher Engineering Science assignment. It must be read in conjunction with the course specification.

This assignment has 50 marks out of a total of 160 marks available for the course assessment.

This is one of two course assessment components. The other component is a question paper.

Instructions for teachers and lecturers

This task is valid for session 2018-19 only. Once complete, you must send the assignment responses to SQA to be marked.

You must conduct the assignment under a high degree of supervision and control.

This means:

- ◆ all candidates must be within your direct sight
- ◆ candidates must not interact with each other
- ◆ candidates must not have access to e-mail, the internet and mobile phones
- ◆ candidates must complete their work independently – no group work is permitted
- ◆ classroom display materials that might provide assistance must be removed or covered
- ◆ there must be no interruption for learning and teaching
- ◆ candidates must be in a classroom environment

Time

Candidates have 8 hours to complete the assignment, starting at an appropriate point in the course after all content has been delivered. Once candidates begin their assignment, they must continue in each subsequent class period until the permitted time allocation has been used up.

You have a responsibility to manage candidates' work, distributing it at the beginning and collecting it at the end of each period, and storing it securely in-between. This activity does not count towards the total time permitted for candidates to complete the assignment.

Resources

This is a closed-book assessment. Candidates must not have access to learning and teaching materials, the internet, notes, exemplar materials, resources on classroom walls or anything similar.

A data booklet containing relevant data and formulae is available on the Higher Engineering Science subject page on SQA's website. This can be used for the assignment.

Each assignment assessment task includes instructions and details of any equipment or materials required for the assignment. Candidates can also use normal classroom equipment, software and hardware (such as drawing instruments, pneumatics, mechanisms and electronics kit, simulation software, and PCs to run the software) to complete the tasks.

There may be instances where restriction of internet and/or network use is not practical or feasible (for example, if you have a local authority-managed network with specific limitations, software that is web-based, or something similar), however, it remains your professional responsibility to make every effort to meet the assessment conditions.

Reasonable assistance

Candidates must progress through each stage of the assignment without your intervention or guidance, having acquired the skills earlier in the course.

Once candidates complete the assignment, you must not return it to them for further work. You must not provide feedback to candidates or offer your opinion on the perceived quality or completeness of the assignment response at any stage.

You can provide reasonable assistance to support candidates with the following aspects of their assignment:

- ◆ printing, collating and labelling their evidence to ensure it is in the format specified by SQA
- ◆ ensuring candidates have all the materials and equipment required to complete the assignment
- ◆ understanding the information outlined in these instructions

Evidence

All candidate evidence (whether created manually or electronically) must be submitted to SQA in paper-based format.

Each task details what evidence is required and how many pages are expected. This is a guide to ensure that candidates do not produce too much or spend too long on a single task.

Candidates must submit single-sided A4 pages. The pages must not have anything fixed to them. Any screenshots, simulation printouts and/or images must be clear and easy to read.

Alteration or adaptation

You must not alter, adapt or modify the assignment in any way. This includes moving the content of the assignment into a different format or workbook. All candidates must undertake the assignment exactly as it is provided by SQA.

Submission

Each piece of work must be labelled with the task number, for example task 2a, and the back of each page must be clearly labelled with the candidate's details.

Photographs must show the candidate's name next to the piece of work.

Only pages containing candidate evidence are to be submitted and evidence must be submitted in task order.

Volume

There is no word or page count.

Specific instructions for teachers and lecturers: 2018-19 assignment

You must follow these specific instructions. You must ensure that candidates are aware of the assessment conditions and know what they should do for each task.

This assignment has five mandatory tasks. Candidates can complete the tasks in the order presented or in an order that helps manage classroom equipment.

Each task has a notional time allocated to it – this provides an indication of how long candidates should spend on the task.

All tasks must be completed on A4 single-sided paper or the worksheet provided, with the task number clearly labelled.

Any evidence printed (screenshots or images) **must be clear and easy to read.**

Task 1 (7 marks)

Notional time: 1 hour

- ◆ task 1: completed on up to four single-sided A4 pages
- ◆ task 1a: candidates **must not use simulation software for this task**
- ◆ task 1c: a worksheet is provided for this task

Task 2 (14 marks)

Notional time: 2 hours and 30 minutes

- ◆ task 2: completed on up to four single-sided A4 pages
- ◆ task 2b: a worksheet is provided for this task
- ◆ task 2d: a worksheet is provided for this task

Task 3 (8 marks)

Notional time: 1 hour and 30 minutes

- ◆ task 3: completed on up to two single-sided A4 pages

Task 4 (6 marks)

Notional time: 30 minutes

- ◆ task 4: completed on up to one single-sided A4 page

Task 5 (15 marks)

Notional time: 2 hours and 30 minutes

- ◆ task 5: completed on up to four single-sided A4 pages
- ◆ task 5b: a worksheet is provided for this task

Note: electronically-generated evidence (for example, simulations and coding) is included in the expected number of pages for each task. This must be printed off and compiled for uplift by SQA.

Instructions for candidates

This assessment applies to the assignment for Higher Engineering Science.

The assignment has 50 marks out of a total of 160 marks for the course assessment.

It assesses the following skills, knowledge and understanding:

- ◆ demonstrating engineering science skills and creativity
- ◆ analysing engineering problems
- ◆ designing and building/simulating solutions to engineering problems
- ◆ testing and evaluating solutions to engineering problems

This is a closed-book assessment. Your teacher or lecturer will let you know how the assessment will be carried out and any specific conditions for doing it.

In this assessment, you have to:

- ◆ analyse a problem
- ◆ design a solution to the problem
- ◆ simulate or construct your solution
- ◆ test your solution
- ◆ evaluate your work

You have 8 hours to complete the assignment. The time to set and clear away equipment you need, and for any printing that is necessary, does not count towards the 8 hours.

You should complete all of the tasks in the order presented, unless otherwise instructed.

For each task, you will be provided with an engineering science problem or situation.

The assignment has five tasks, with marks allocated as follows:

Task 1 – 7 marks: designing, building, testing, and evaluating a solution (electronics) for the control of a flavoured ice drinks machine
(designing a solution = 3 marks, building = 2 marks, testing = 1 mark, evaluating = 1 mark)

Task 2 – 14 marks: building, testing, and evaluating a solution (electronics) for a fast pass ticket machine
(building = 3 marks, testing = 7 marks, evaluating = 4 marks)

Task 3 – 8 marks: designing and building a solution (pneumatics and structures) for a water flume ride
(designing a solution = 6 marks, building = 2 marks)

Task 4 – 6 marks: analysing a solution (control) for the ride queue air conditioning control system
(analysis = 6 marks)

Task 5 – 15 marks: building, testing, and evaluating a solution (electronics and programmable control) for a rollercoaster ride control
(building = 5 marks, testing = 5 marks, evaluating = 5 marks)

Submitting your work

Your teacher or lecturer will let you know the approximate amount of time to spend on each task, along with an indication of the number of single-sided A4 pages of evidence that you should produce.

You must label each piece of evidence in task order, with the task number (for example, task 2a), and on the back of each page include your:

- ◆ name
- ◆ date of birth
- ◆ Scottish Candidate Number (SCN)
- ◆ centre name
- ◆ centre number

Candidate data sheets – theme park

You can use these data sheets and SQA's Higher Data Booklet when completing this assignment. **No other resource material is permitted.**

Electronic components

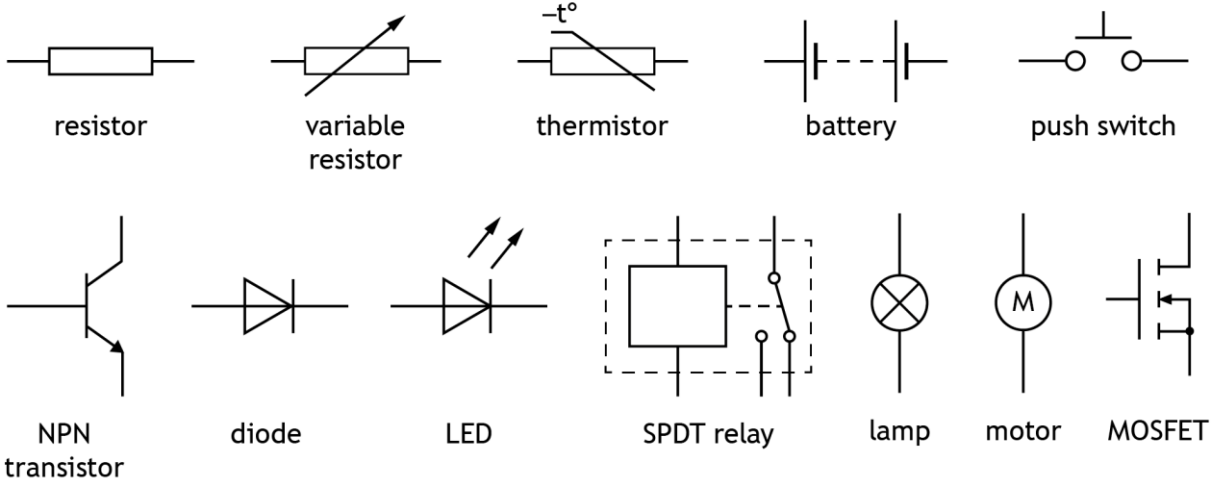

IC pinout diagrams

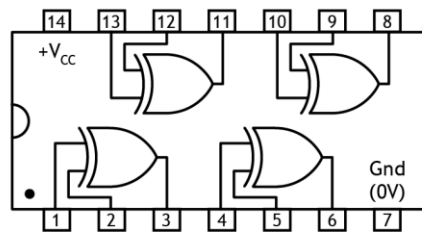
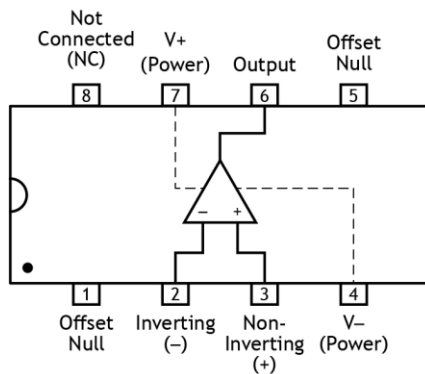
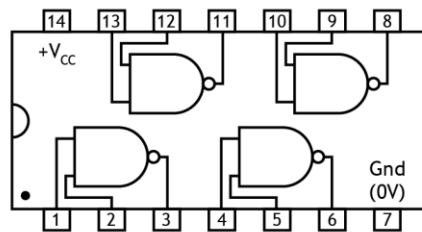
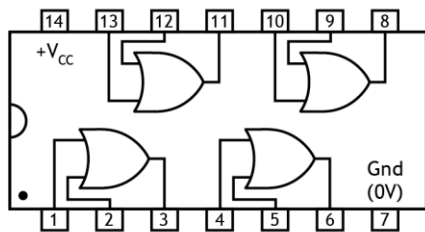
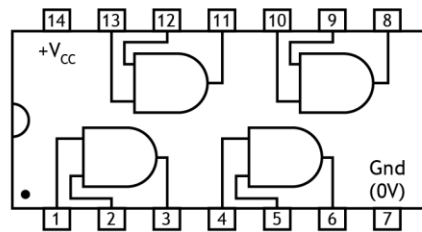
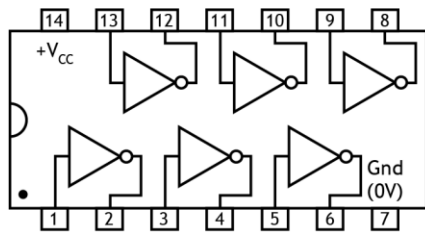

Logic gates

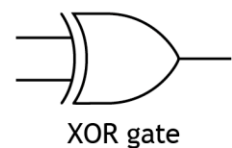
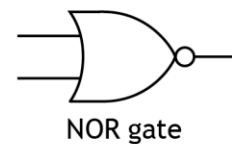
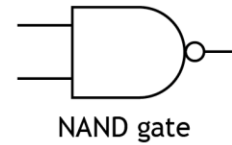
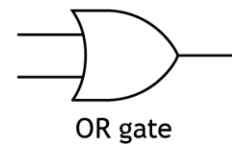
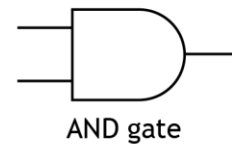
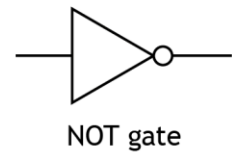

Thermistor graph

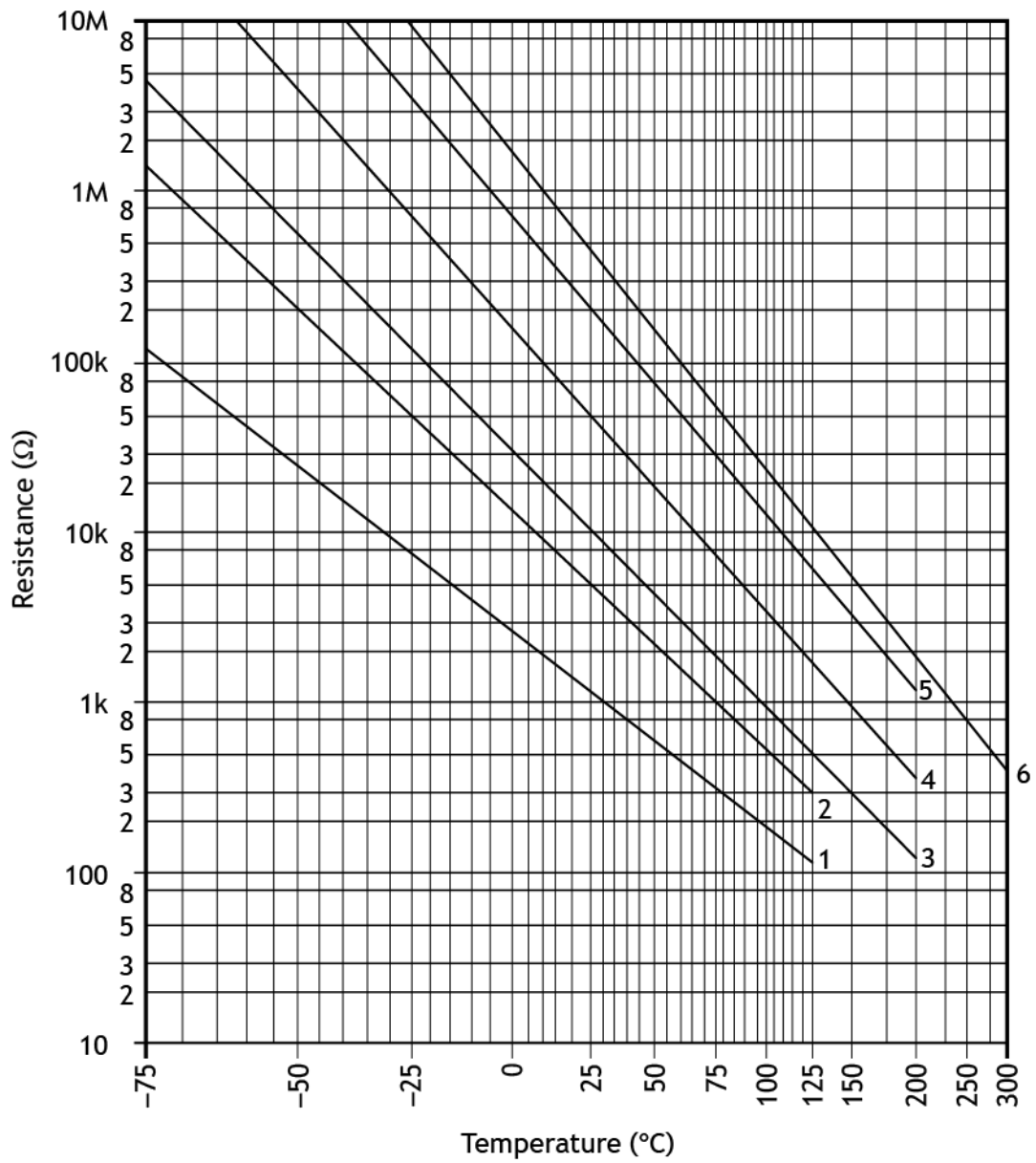

Light Dependent Resistor (LDR) graph for an ORP12 LDR

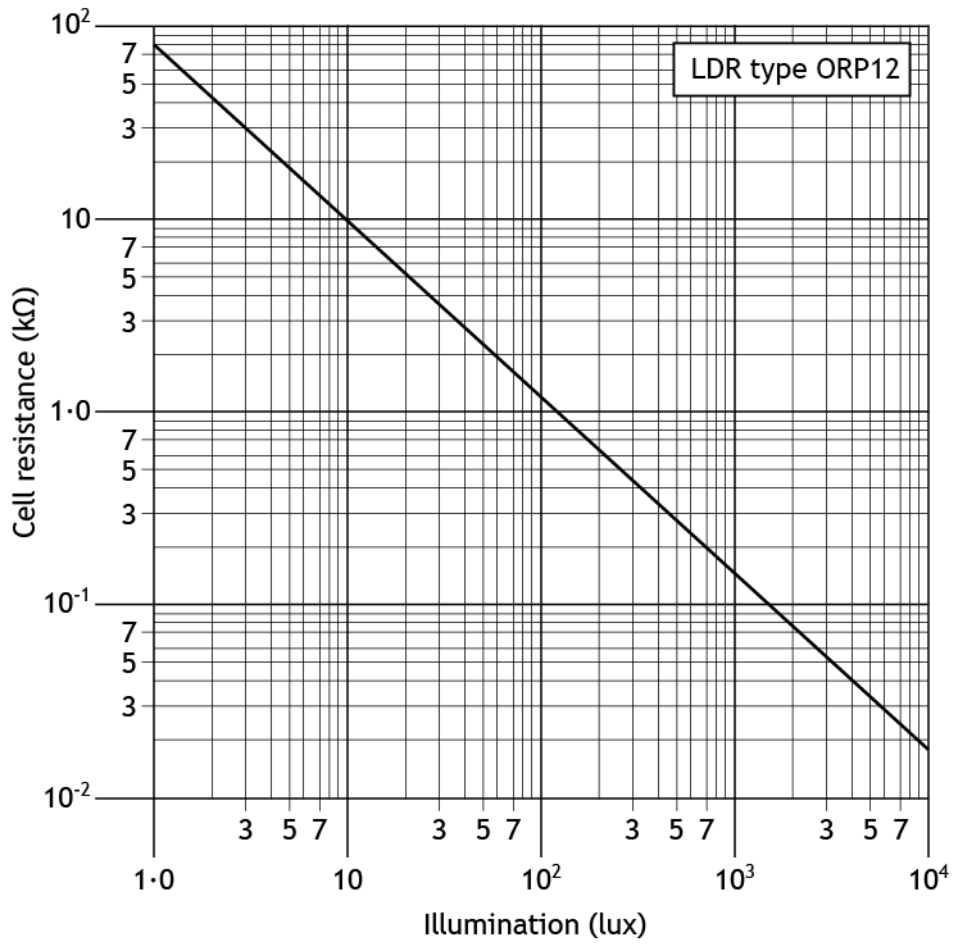

Actuators



solenoid



plunger

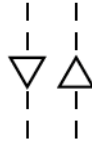

diaphragm



spring
return



pilot air

Valves

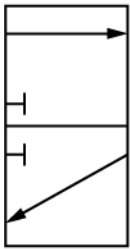

3/2 valve

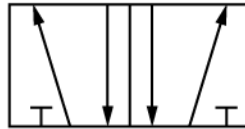

5/2 valve



main air



exhaust

Components and cylinders

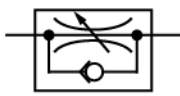

unidirectional
restrictor

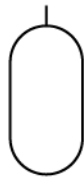

reservoir

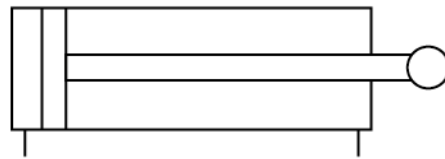

double acting cylinder

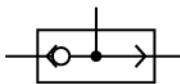

shuttle
valve



push button
actuator

Theme park

A team of engineers is involved in several tasks during the planning and designing of a new theme park.

The tasks include the development of proposals for the following:

Task 1 – flavoured ice drinks machine

Task 2 – fast pass machine

Task 3 – water flume ride

Task 4 – ride queue air conditioning control system

Task 5 – rollercoaster ride control

Task 1 – flavoured ice drinks machine

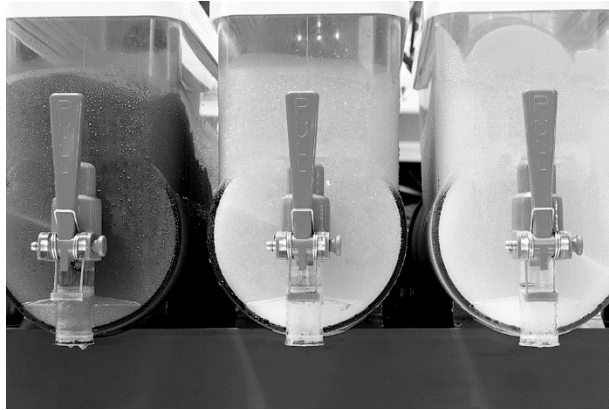

A digital logic circuit is required to control part of a flavoured ice drinks machine, where the operator can mix crushed ice, fizzy water and flavouring.

The following Boolean equation has been developed by an electronic engineer to specify the operation of the machine:

$$Z = (\bar{A} + B) \cdot (C \oplus D)$$

1a Draw a logic circuit diagram to perform this function.

You must not use simulation software to complete this task.

You must present your evidence on A4 single-sided pages, with the task number clearly labelled. Screenshots or images must be clear and easy to read.

(3 marks)

Task 1 – flavoured ice drinks machine (continued)

The engineer redesigns the circuit as a NAND equivalent circuit as shown below.

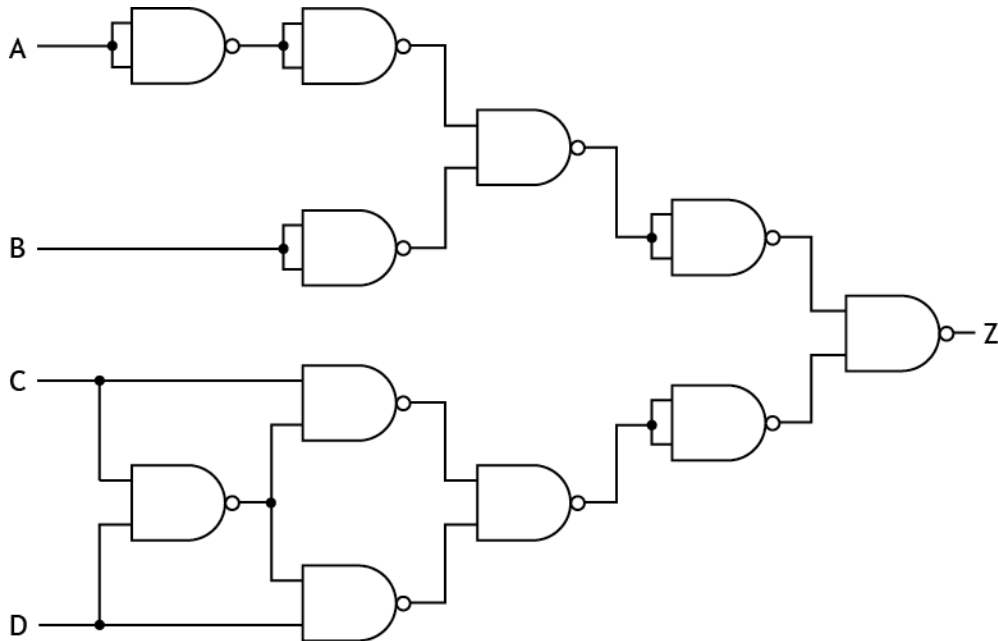

- 1b Simulate or construct the NAND equivalent circuit to allow for testing.

You must present your evidence on A4 single-sided pages, with the task number clearly labelled. Screenshots or images **must be clear and easy to read**.

(2 marks)

The expected test results for the NAND equivalent circuit are shown in **worksheet 1c**.

- 1c Test the NAND equivalent circuit from 1b, and **complete the actual results column on worksheet 1c**.

You must present the completed **worksheet 1c** on A4 single-sided paper, with the task number clearly labelled.

(1 mark)

- 1d Explain why the expected results and actual results differ in **worksheet 1c**.

You must present your evidence on A4 single-sided pages with the task number clearly labelled.

(1 mark)

Task 2 – fast pass machine

A number of attractions in the theme park have a fast pass ticket system, where riders can scan their park tickets and be issued with a fast pass to skip the queues.

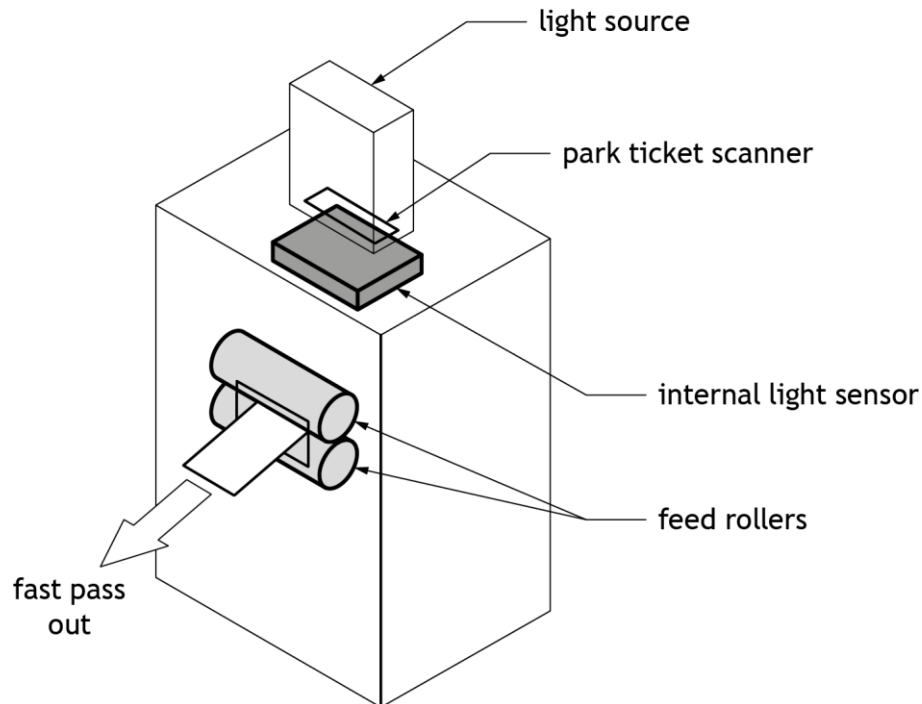

The fast pass machine must meet the following specification.

- i When a park ticket is scanned and darkness is sensed, the fast pass motor will turn on.
- ii The motor slows to rest when the park ticket is removed from the scanner.
- iii The scanner's sensitivity can be adjusted to account for different light conditions.

Task 2 – fast pass machine (continued)

An initial design for the input of the electronic control system for the fast pass machine is shown in the circuit diagram below.

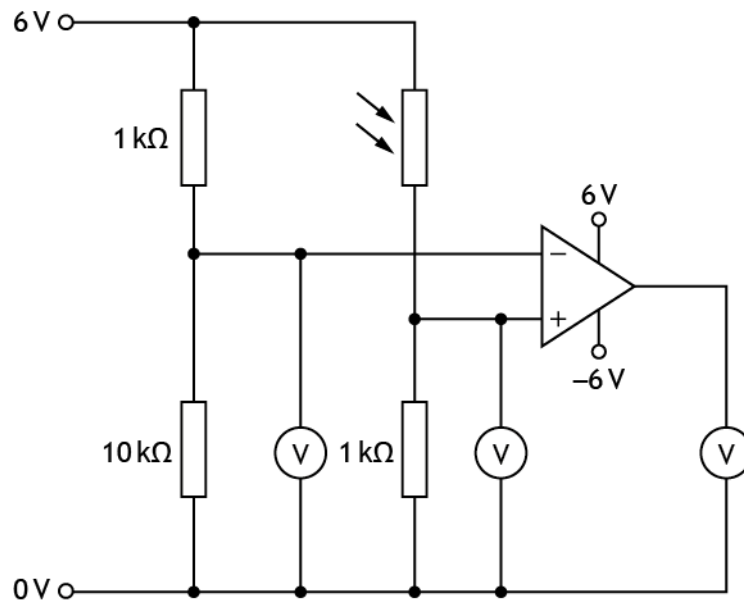

- 2a Simulate or construct this circuit to enable testing.

You must present your evidence on A4 single-sided pages, with the task number clearly labelled. Screenshots or images must be clear and easy to read.

(2 marks)

- 2b Complete the testing table provided on **worksheet 2b** by carrying out the planned tests given, **making amendments as necessary before moving onto the next test.**

You must write descriptions of the actual results you observed during the testing and any appropriate amendments that you made to enable the system to meet the specification.

You must present the completed **worksheet 2b** on A4 single-sided pages with the task number clearly labelled.

(4 marks)

Task 2 – fast pass machine (continued)

The fast pass machine's output is shown in the circuit diagram below.

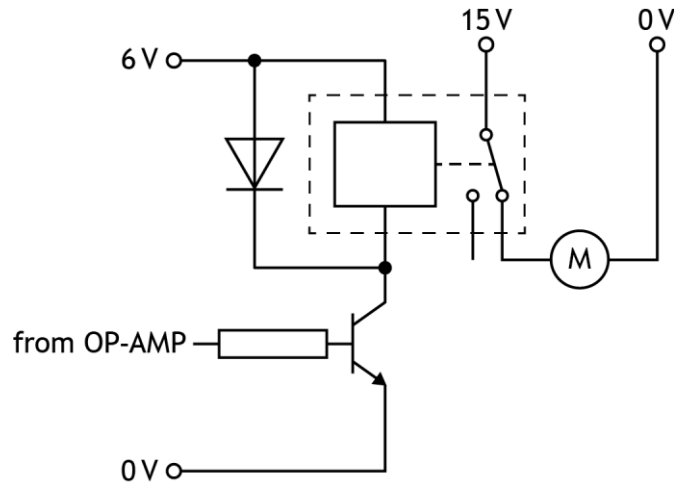

- 2c Simulate or construct the output circuit shown above **by adding** it to your amended circuit from 2b.

You must present your evidence on A4 single-sided pages, with the task number clearly labelled. Screenshots or images **must be clear and easy to read**.

(1 mark)

- 2d Complete, for the circuit in 2c, the testing table provided on **worksheet 2d** by carrying out the planned tests given, **making amendments as necessary before moving onto the next test**.

You must write descriptions of the actual results you observed during the testing and any appropriate amendments that you made to enable the system to meet the specification.

You must present your evidence on A4 single-sided pages, with the task number clearly labelled.

(3 marks)

- 2e Evaluate the performance of your amended solution from **task 2d** against the specification for the fast pass machine. Describe the performance of your amended solution to meet each of the three specification points, referring to testing and any amendments that you may have made.

You must present your evidence on A4 single-sided pages, with the task number clearly labelled. Screenshots or images **must be clear and easy to read**.

(4 marks)

Task 3 – water flume ride

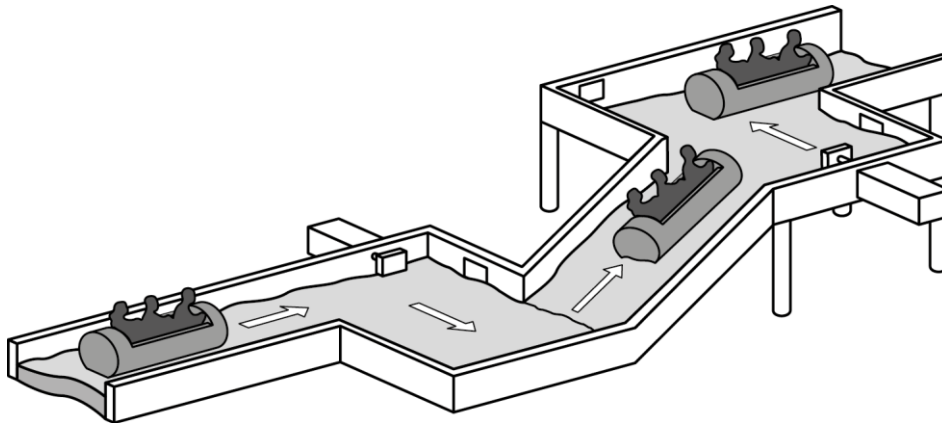

Part of a water flume ride is shown below.

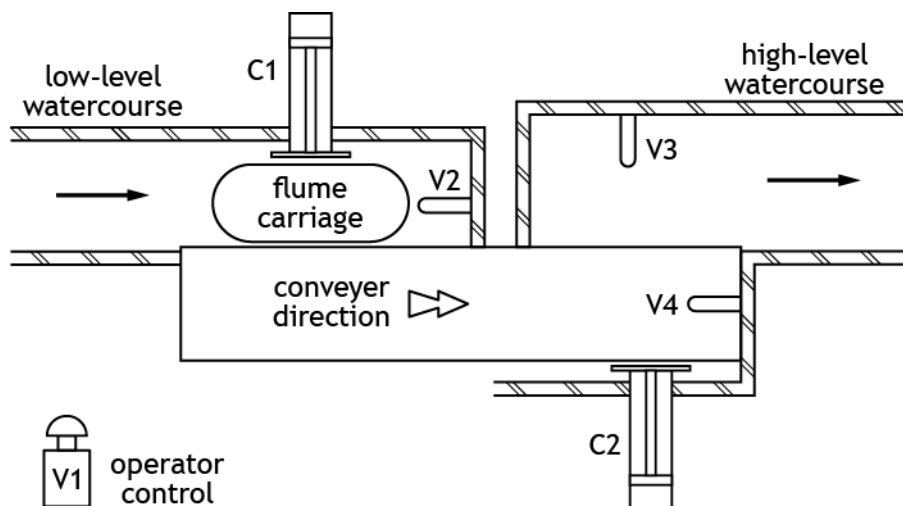

A pneumatic system to transfer the carriage from a low-level watercourse to a high-level watercourse via a conveyor belt must meet the following specification.

- i When the flume carriage actuates the plunger on valve V2, it is pushed slowly from the low-level watercourse by outstroking cylinder C1 onto the conveyor.
- ii When the carriage actuates the plunger on valve V4, it is pushed slowly into the high-level watercourse by outstroking cylinder C2.
- iii The carriage actuates the plunger on valve V3 when safely in the high-level watercourse, instroking cylinders C1 and C2.
- iv Cylinder C1 can also be instroked by the ride operator when a push button is actuated on valve V1 at any time if required.

Task 3 – water flume ride (continued)

- 3a Design, using the correct symbols for the components or block diagrams, a pneumatic circuit to meet the specification.

You must label V1, V2, V3, V4, C1 and C2, and the direction of the piston outstroke on cylinders C1 and C2. Show all required pipe connections between the components.

If using block diagrams, label all pneumatic components.

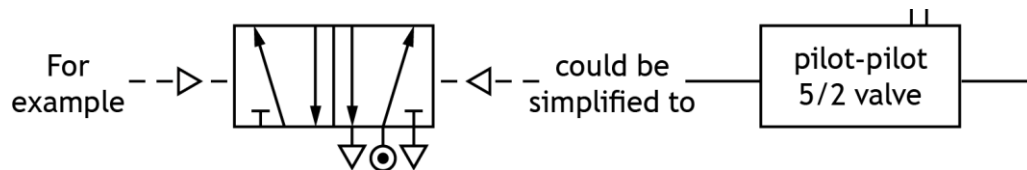

You must present your evidence on A4 single-sided pages, with the task number clearly labelled. Screenshots or images **must be clear and easy to read**.

(6 marks)

Before the conveyor system is constructed, a simulation of the support structure is used to determine reactions.

A diagram of the structure is shown below.

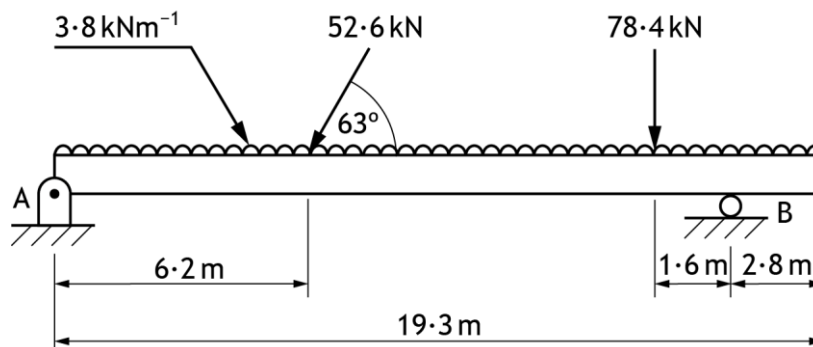

- 3b Simulate this structure to determine the horizontal and vertical reactions at A and B.

You must present your evidence of simulation and horizontal and vertical reaction, on A4 single-sided pages, with the task number clearly labelled. Screenshots or images **must be clear and easy to read**.

(2 marks)

Task 4 – ride queue air conditioning control system

An electronic control system for an air conditioning unit is to be installed in the interior queuing areas for the rides.

The system must meet the following specification.

- i Theme park staff set the desired temperature of the queuing area.
 - ii Whenever the temperature rises above the desired level, a motorised fan switches on.
 - iii Whenever the temperature drops below the desired level, the motorised fan switches off.
- 4 Analyse the above specification by producing a control diagram. Clearly show the input and output.

You must present your evidence on A4 single-sided pages, with the task number clearly labelled. Screenshots or images **must be clear and easy to read**.

(6 marks)

Task 5 – rollercoaster ride control

A microcontroller is used to operate parts of a rollercoaster.



An electronic engineer has designed the **flowchart** and **circuit** shown as a possible solution.

Task 5 – rollercoaster ride control (continued)

Note: a_Input 4 is an analogue input.

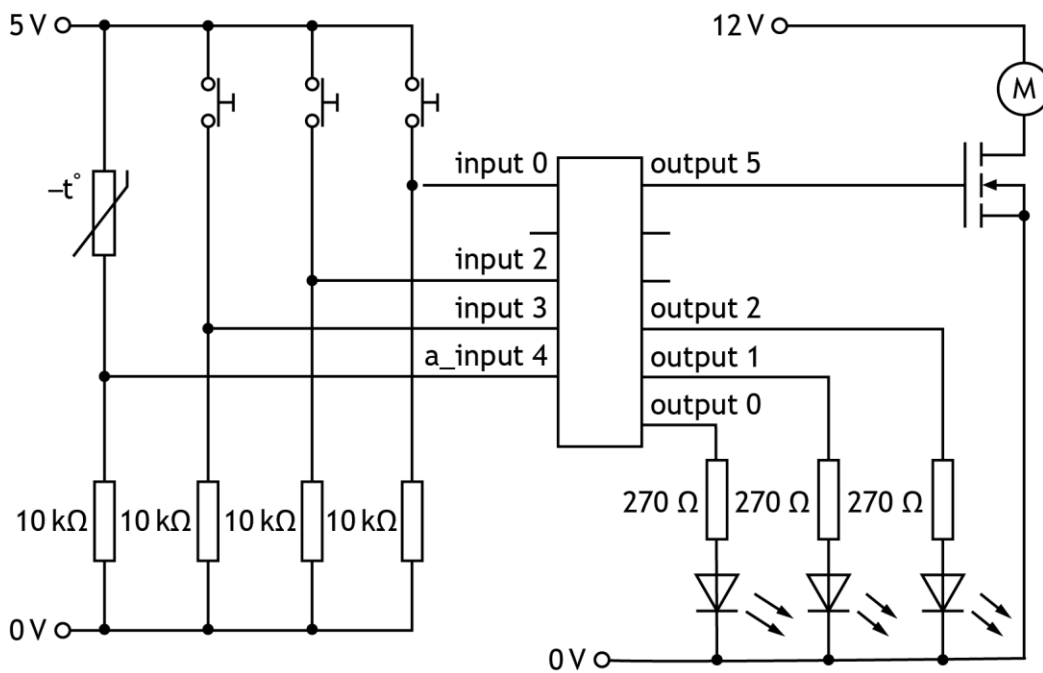
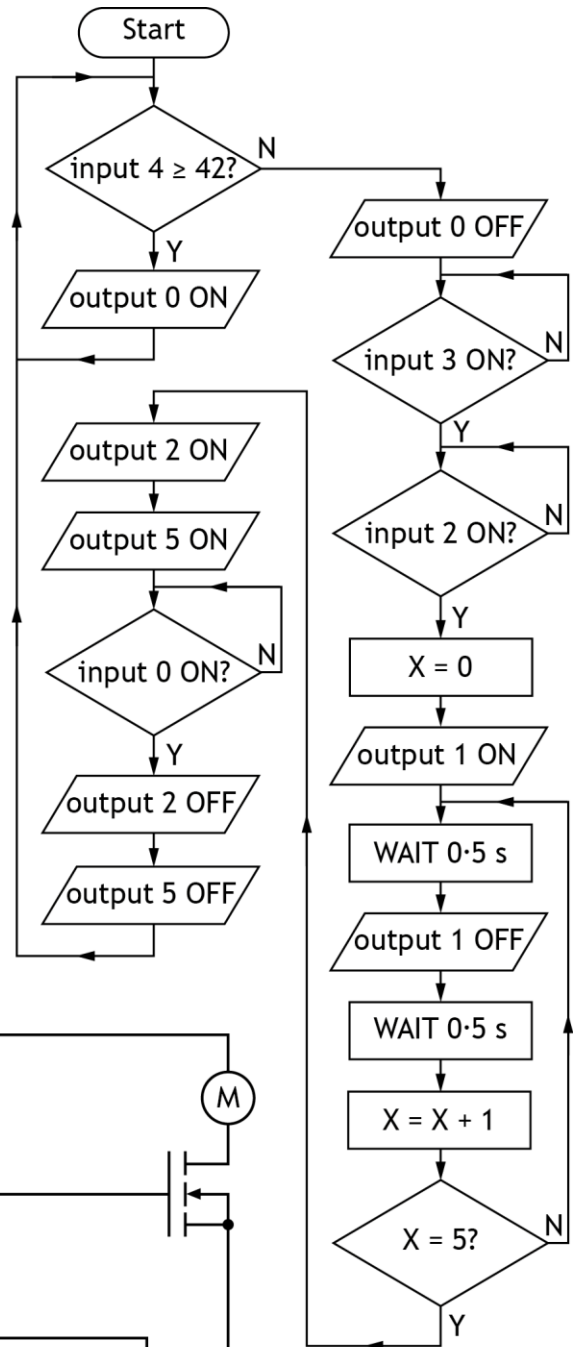

Task 5 – rollercoaster ride control (continued)

- 5a Simulate or construct the flowchart and electronic circuit **integrated together** as shown.

You must present your evidence on A4 single-sided pages, with the task number clearly labelled. Screenshots or images **must be clear and easy to read**.

(3 marks)

The design of the electronic circuit was tested and found to be correct but errors were discovered in the flowchart.

- 5b Test your simulation or construction against the following aspects of the system specification below and complete the table provided in **worksheet 5b**.
- i If the temperature is below a set value, a warning indicator turns on.
 - ii The rollercoaster can only be started when the track temperature is safe, the ‘harness safety check complete’ switch has been pressed, and the operator switch has been pressed.
 - iii When the ‘harness safety check complete’ switch is pressed, the ‘harness check complete’ indicator will flash 5 times.
 - iv The ‘ride on’ indicator and the motor will be on until the ‘ride end’ switch has been pressed.

Microcontroller pin connections			
Input 0	‘ride end’ switch	Output 0	‘temperature warning’ indicator
Input 1		Output 1	‘harness check complete’ indicator
Input 2	operator switch	Output 2	‘ride on’ indicator
Input 3	‘harness safety check complete’ switch	Output 3	
a_Input 4	temperature sensor	Output 4	
		Output 5	motor

You must write descriptions of the actual results you observed during the testing, and appropriate amendments that you made to enable the system to satisfy the specification.

You must present your evidence on A4 single-sided pages, with the task number clearly labelled. Screenshots or images **must be clear and easy to read**.

(5 marks)

Task 5 – rollercoaster ride control (continued)

5c Draw or simulate your amended flowchart from your testing in **task 5b**.

You must present your evidence on A4 single-sided pages, with the task number clearly labelled. Screenshots or images **must be clear and easy to read**.

(2 marks)

5d Evaluate the performance of your amended flowchart from **task 5c** against the specification in **task 5b**, by describing:

- i how your amended solution meets all the specification points – you should do this by referring to testing and any amendments you may have made
- ii the overall effectiveness of your amended solution in controlling the safety checks

You must present your evidence on A4 single-sided pages, with the task number clearly labelled. Screenshots or images **must be clear and easy to read**.

(5 marks)

[END OF ASSIGNMENT]



Higher Engineering Science Assignment

Assessment task: theme park Worksheets

This document provides information for teachers and lecturers about the coursework component of this course in terms of the skills, knowledge and understanding that are assessed. It **must** be read in conjunction with the course specification.

Valid for session 2018-19 only.

The information in this publication may be reproduced in support of SQA qualifications only on a non-commercial basis. If it is reproduced, SQA must be clearly acknowledged as the source. If it is to be reproduced for any other purpose, written permission must be obtained from permissions@sqa.org.uk.

Where this publication includes material for which SQA does not own the copyright, this material must only be reproduced on a non-commercial basis for the purposes of instruction in an educational establishment. If it is to be reproduced for any other purpose, it is the user's responsibility to obtain the necessary copyright clearance from the copyright owner. The acknowledgements page lists the owners of copyright items that are not owned by SQA.

This edition: January 2019 (version 1.0)

© Scottish Qualifications Authority 2019

Worksheet 1c

Complete the actual results column on the truth table below.

A	B	C	D	Expected results	Actual results
0	0	0	0	0	
0	0	0	1	1	
0	0	1	0	1	
0	0	1	1	0	
0	1	0	0	0	
0	1	0	1	1	
0	1	1	0	1	
0	1	1	1	0	
1	0	0	0	0	
1	0	0	1	0	
1	0	1	0	0	
1	0	1	1	0	
1	1	0	0	0	
1	1	0	1	1	
1	1	1	0	1	
1	1	1	1	0	

(1 mark)

Name:	
Date of birth:	
Scottish Candidate Number (SCN):	
Centre name:	
Centre number:	

Worksheet 2b

Complete the testing table shown below.

Planned test	Expected result	Actual result	Amendments made
Reduce the light level to the minimum setting.	Op amp output saturates positive.		
Alter the light level until op amp changes state.	Op amp output changes state at 3V.		

(4 marks)

Name:	
Date of birth:	
Scottish Candidate Number (SCN):	
Centre name:	
Centre number:	

Worksheet 2d

Complete the testing table shown below.

Planned test	Expected result	Actual result	Amendments made
Reduce the light level to minimum.	Motor turns.		
Alter the value of both the LDR and the fixed resistor to $6k\Omega$.	The motor turns on under different lighting conditions.		

(3 marks)

Name:	
Date of birth:	
Scottish Candidate Number (SCN):	
Centre name:	
Centre number:	

Worksheet 5b

Complete the testing table shown below.

Planned test	Expected result	Actual result	Amendments made
Adjust the thermistor temperature to its lowest value.	The 'temperature warning' indicator should be on.		
Adjust the thermistor temperature to its highest value.	The 'temperature warning' indicator should switch off – the flowchart should progress to the next decision.		
Press the 'harness safety check complete' switch and the 'operator switch' in sequence.	The 'harness safety check complete' indicator should flash five times.		

(5 marks)

Name:	
Date of birth:	
Scottish Candidate Number (SCN):	
Centre name:	
Centre number:	

Acknowledgement of copyright
Page 13: pavla/shutterstock.com
Page 21: liewluc/shutterstock.com

Administrative information

Published: January 2019 (version 1.0)

History of changes

Version	Description of change	Date

Note: you are advised to check SQA's website to ensure you are using the most up-to-date version of this document.

Security and confidentiality

This document can be used by SQA approved centres for the assessment of National Courses and not for any other purpose.