

FOR OFFICIAL USE



National  
Qualifications  
2021 ASSESSMENT RESOURCE

Mark

**X823/76/01**

**Engineering Science**

Duration — 2 hours 30 minutes



Fill in these boxes and read what is printed below.

Full name of centre

Town

Forename(s)

Surname

Number of seat

Date of birth

Day

Month

Year

Scottish candidate number

**Total marks — 110**

**SECTION 1 — 20 marks**

Attempt ALL questions.

**SECTION 2 — 90 marks**

Attempt ALL questions.

**Show all working and units where appropriate.**

You should refer to the Higher Engineering Science Data Booklet which you have been given. The number of significant figures expressed in a final answer should be equivalent to the least significant data value given in the question. Answers that have two more figures or one less figure than this will be accepted.

Write your answers clearly in the spaces provided in this booklet. Additional space for answers is provided at the end of this booklet. If you use this space you must clearly identify the question number you are attempting.

Use **blue** or **black** ink.

Before leaving the examination room you must give this booklet to the Invigilator; if you do not, you may lose all the marks for this paper.



SECTION 1 — 20 marks

Attempt ALL questions

1. A load extension graph for a material is shown below.

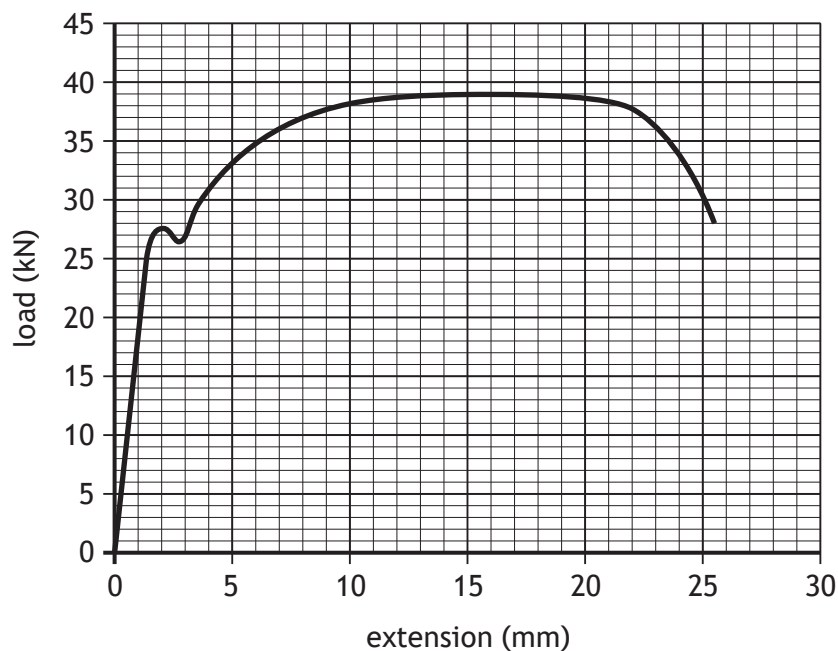

Describe what happens to the material when

(a) a 15 kN force is applied and removed 1

---



---



---

(b) a 35 kN force is applied and removed. 1

---



---



---



2. An op-amp circuit is shown below.

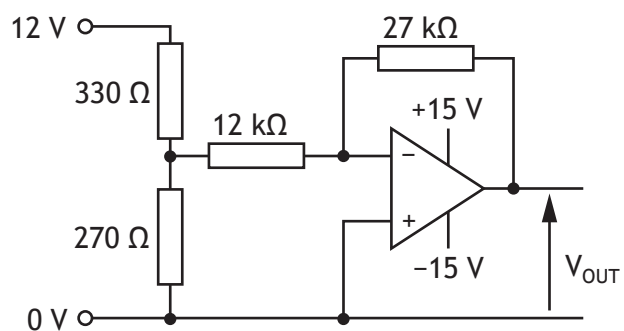

Calculate  $V_{OUT}$ .

3

[Turn over



\* X 8 2 3 7 6 0 1 0 3 \*

3. A walkway has a uniformly distributed load and point load applied as shown in the diagram below.

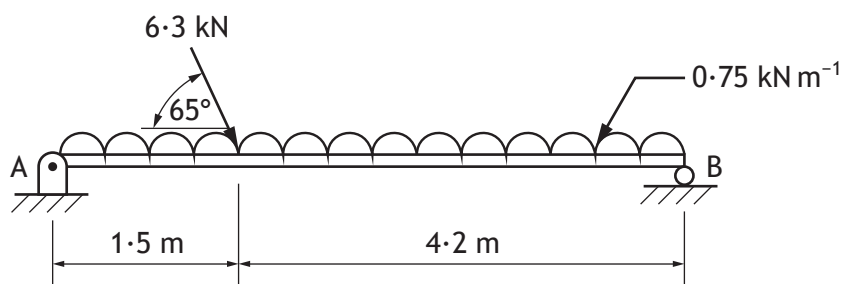

Calculate the magnitude and direction of the reaction force at B.

5



\* X 8 2 3 7 6 0 1 0 4 \*

4. The ship shown below is used to transport liquefied natural gas.



Describe two pieces of specialised knowledge required by a structural engineer during the design of the ship.

2

Knowledge 1 \_\_\_\_\_

\_\_\_\_\_  
\_\_\_\_\_  
\_\_\_\_\_

Knowledge 2 \_\_\_\_\_

\_\_\_\_\_  
\_\_\_\_\_  
\_\_\_\_\_

[Turn over



\* X 8 2 3 7 6 0 1 0 5 \*

5. A motor is used in the cooling system within a mini fridge.



- (a) The motor has a power rating of 4.6 W and 12 V.  
Calculate the resistance of the motor.

1



5. (continued)

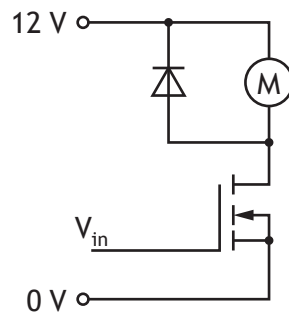

- (b) The MOSFET has a drain current of 0.38 A.  
Calculate the resistance of the MOSFET.

2

- (c) Calculate the power dissipated by the MOSFET.

1

[Turn over



\* X 8 2 3 7 6 0 1 0 7 \*

6. A logic diagram is shown below.

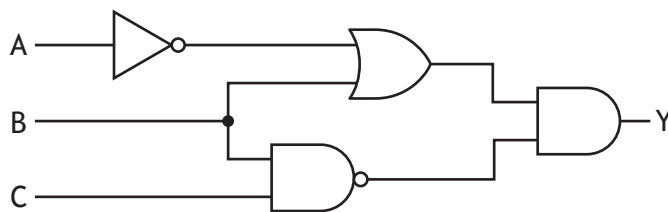

Draw a NAND equivalent for this circuit. Simplify if appropriate.

4



[Turn over for next question

DO NOT WRITE ON THIS PAGE



\* X 8 2 3 7 6 0 1 0 9 \*

SECTION 2 — 90 marks

Attempt ALL questions

DO NOT  
WRITE IN  
THIS  
MARGIN

7. An engineering team produced a prototype system to smooth sand in a long jump pit once an athlete has completed their jump.

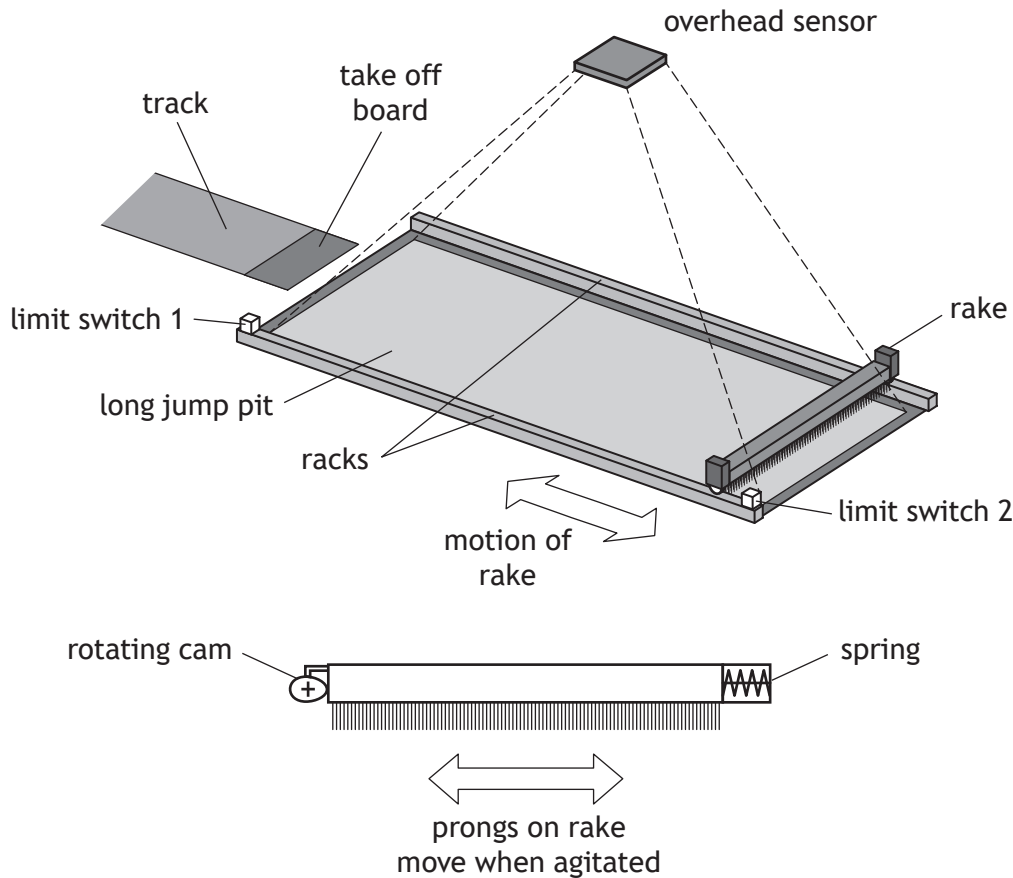

The system must meet the following specification.

- i. An operator presses a switch to begin the smoothing process
- ii. The rake moves forward at full speed until limit switch 1 is pressed
- iii. The rake then moves backward at half speed until limit switch 2 is pressed
- iv. If an overhead sensor indicates that the pit is not fully smooth then an agitator motor switches on and steps ii and iii are repeated once
- v. The system resets and waits for the next press of the operator's switch

Input	Pin	Output
	7	rake motor forward
	6	rake motor backward
	5	agitator motor
overhead sensor (high — when smooth surface sensed)	3	
limit switch 2	2	
limit switch 1	1	
operator switch	0	



7. (continued)

MARKS

DO NOT  
WRITE IN  
THIS  
MARGIN

(a) Draw a flowchart to show the control of the smoothing system.

8

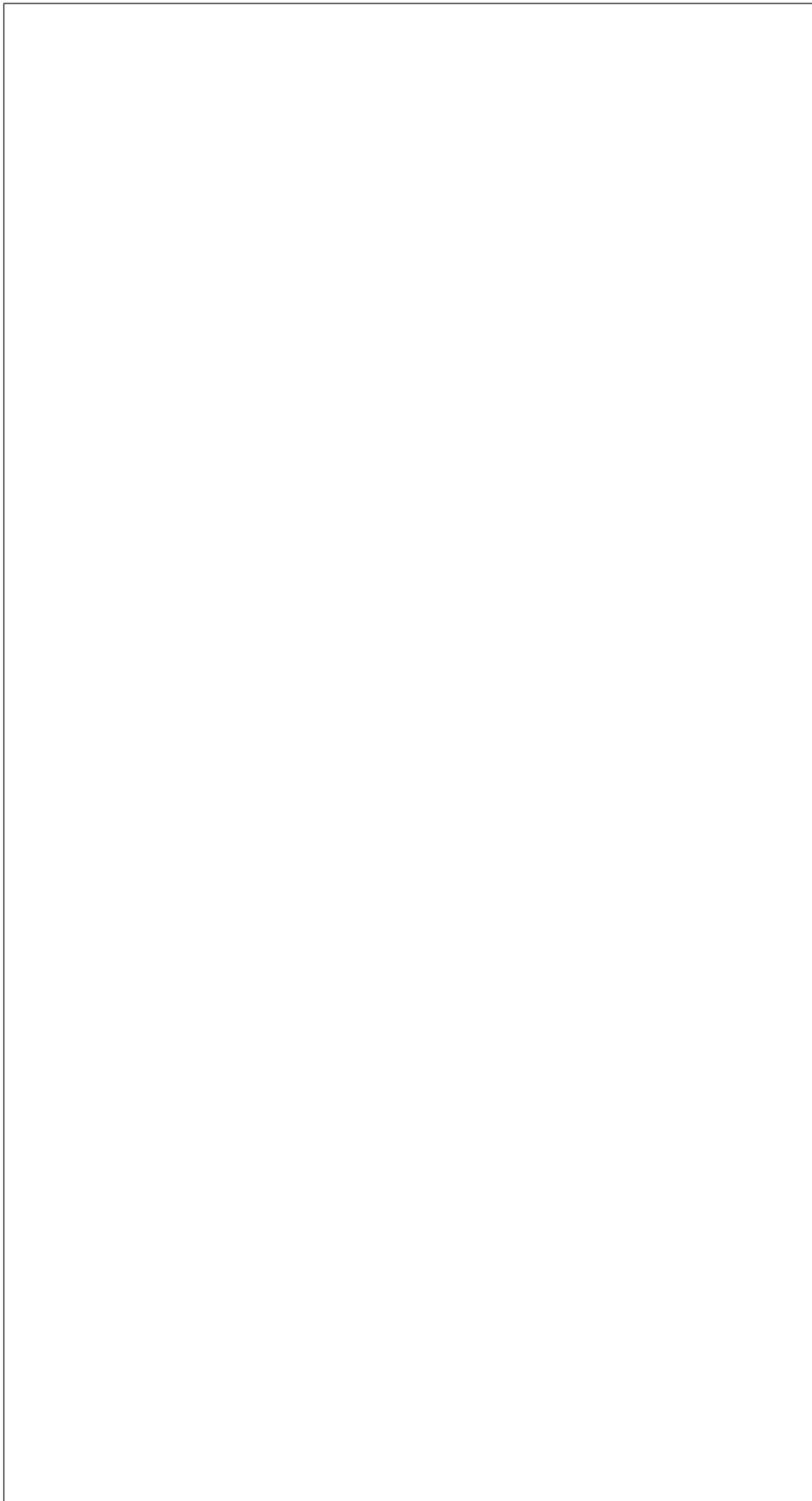

\* X 8 2 3 7 6 0 1 1 1 \*

7. (continued)

An alternative method of controlling the rake motor is shown below. When current flows from left to right through the motor it will spin clockwise.

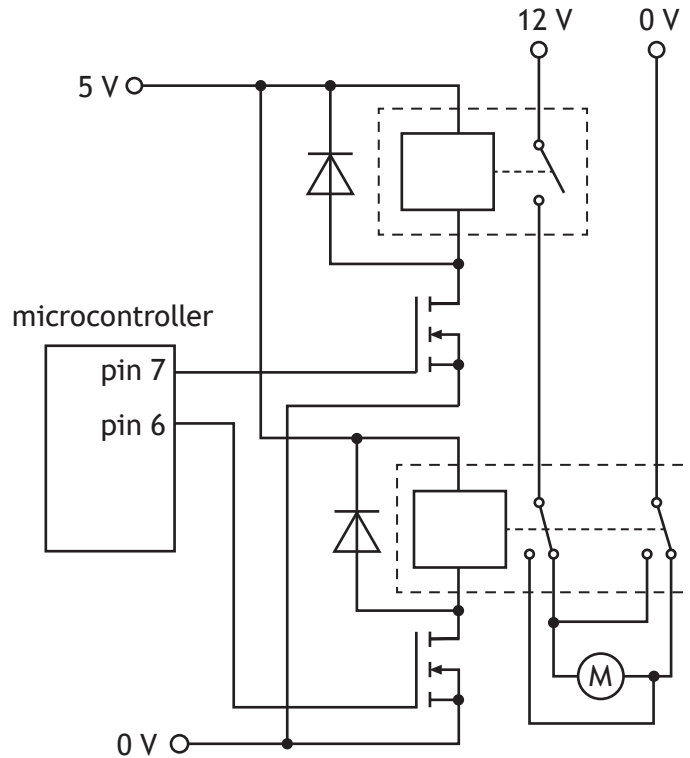

- (b) Describe, with reference to the output pins shown above, how the motor could be made to rotate in each direction and switch off.

3

---



---



---



---



---



---



---



---



---



8. Plants need to be kept in a polytunnel with a constant light level to ensure they grow correctly. This is done by using banks of powerful LEDs to provide additional light when the outside light level drops.

The initial design for the electronic control system is shown below. The light sensor monitors the light level **outside** the polytunnel.

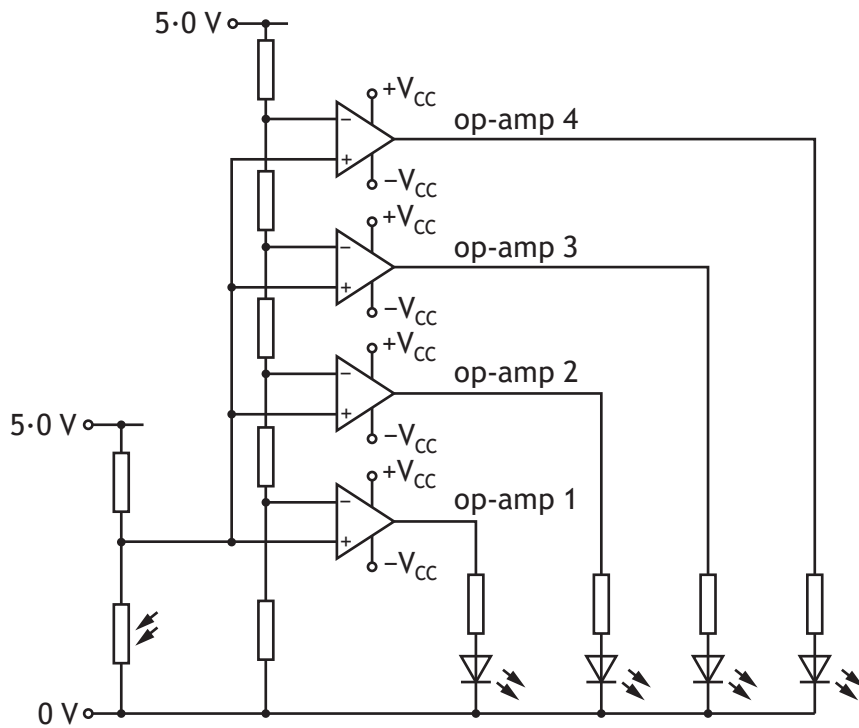

- (a) Describe, with reference to this circuit, the operation of the LED connected to **op-amp 1** as the outside light level decreases from a high level to a low level.

3

---



---



---



---



---



---



\* X 8 2 3 7 6 0 1 1 3 \*

8. (continued)

DO NOT WRITE IN THIS MARGIN

During testing, it was found that the system did not work as well as expected, so it was redesigned. A diagram of the redesigned circuit is shown below.

In this instance, the light sensor was placed **inside** the polytunnel.

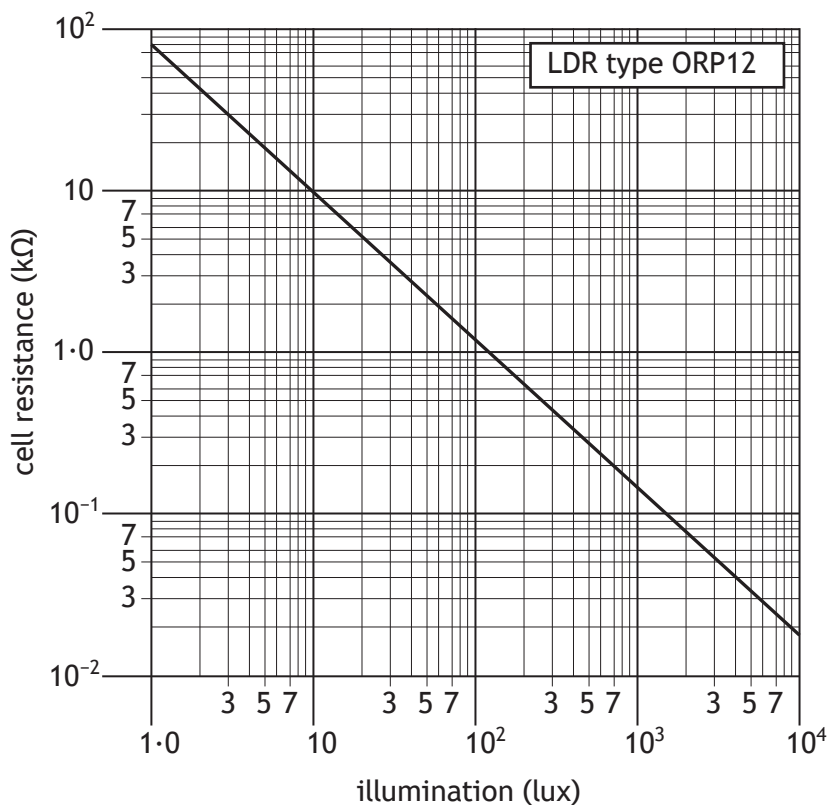
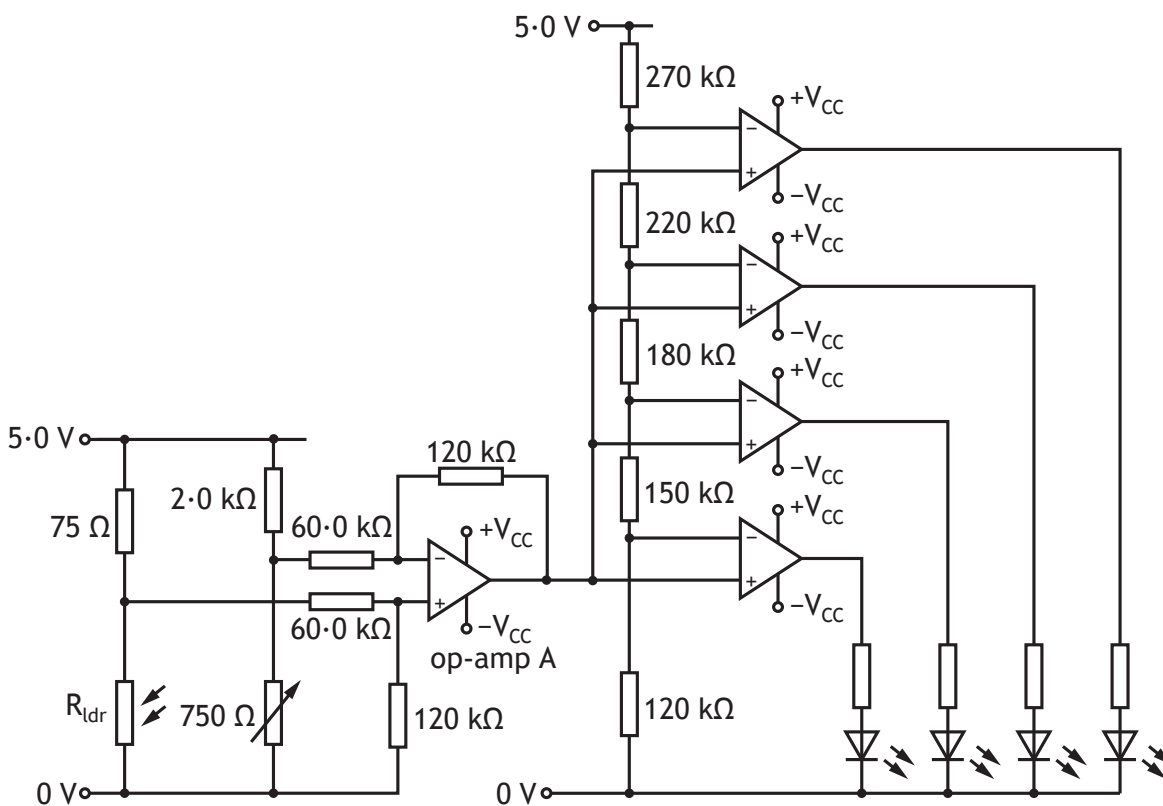

\* X 8 2 3 7 6 0 1 1 4 \*

## 8. (continued)

- (b) Calculate the output voltage of the difference amplifier when the light level is 700 lux.

4

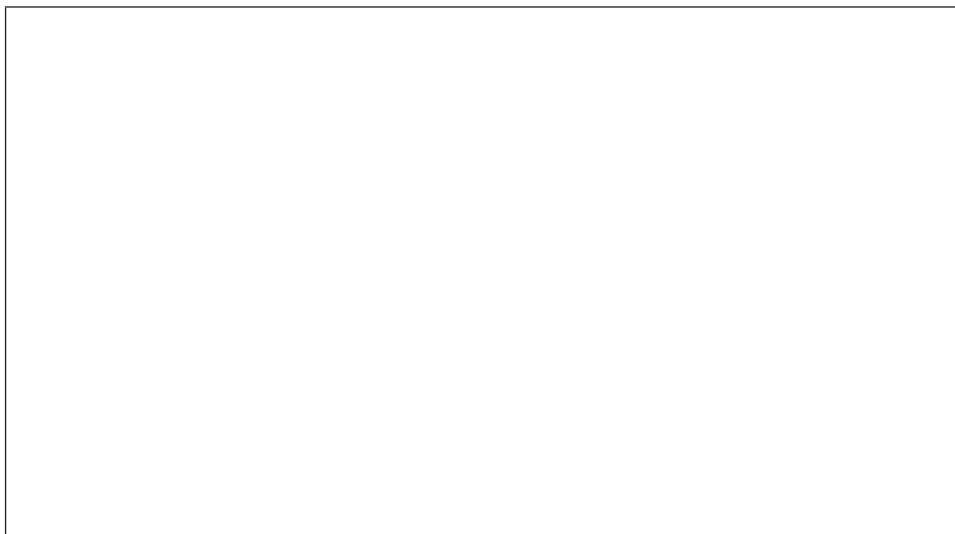

- (c) Calculate the minimum output voltage required from the difference amplifier to cause **three** LEDs to come on.

2

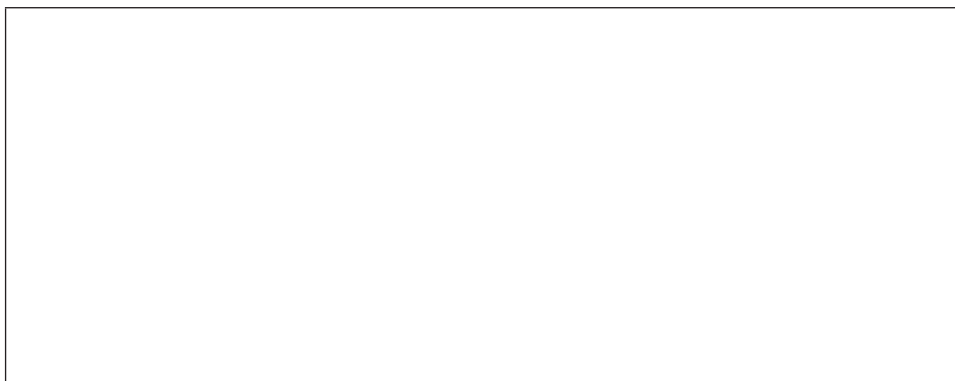

- (d) Describe the effect that adjusting the variable resistor will have on the light level required to make the LEDs light.

2

---

---

---

---

---

---

---



\* X 8 2 3 7 6 0 1 1 5 \*

8. (continued)

The LEDs are at their most efficient when a current of 5.2 mA flows through each one. They are also found to have a 2.3 V drop across them when they are on.

- (e) Calculate the required resistance for the protective resistors to ensure maximum efficiency.

$+V_{cc}$  for the comparators is set to 8.0 V. The comparator saturates at 85%. **3**

A further solution involving the use of a microcontroller is also tested, and is shown below. One output pin on the microcontroller activates a bank of LEDs.

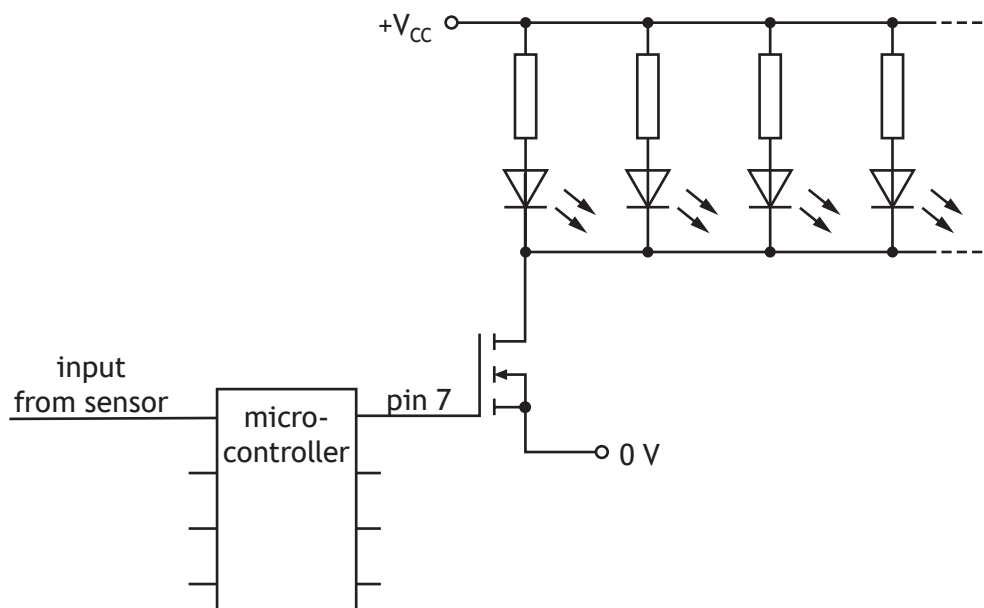

\* X 8 2 3 7 6 0 1 1 6 \*

## 8. (continued)

By using pulse width modulation, the LEDs can be made to appear bright or dim.

Code for the test is shown below, in **PBASIC** and **Arduino**.

<pre> main:   readadc pin0, b0    if b0 &lt;50 then level1   if b0 &lt;100 then level2   if b0 &lt;150 then level3    let mark = 0   let space = 10   goto pulser  level1:   let mark = 10   let space = 0   goto pulser  level2:   let mark = 6   let space = 4   goto pulser  level3:   let mark = 3   let space = 7  pulser:   high 7   pause mark   low 7   pause space  goto main </pre>	<pre> int Sensor = A0; int LEDBank = 7;  void setup() {   pinMode(LEDBank, OUTPUT); }  void loop() {   int reading=analogRead(Sensor);   int value=map(reading,0,1023,0,255);   if(value&lt;50) {     digitalWrite(LEDBank, HIGH);     delay(10);     digitalWrite(LEDBank, LOW);     delay(0);   }   if(value&gt;49&amp;&amp;value&lt;100) {     digitalWrite(LEDBank, HIGH);     delay (6);     digitalWrite(LEDBank, LOW);     delay (4);   }   if(value&gt;99&amp;&amp;value&lt;150) {     digitalWrite(LEDBank, HIGH);     delay(3);     digitalWrite(LEDBank, LOW);     delay(7);   }   else {     digitalWrite (LEDBank, HIGH);     delay (0);     digitalWrite (LEDBank, LOW);     delay (10);   } } </pre>
---	---



\* X 8 2 3 7 6 0 1 1 7 \*

[BLANK PAGE]

DO NOT WRITE ON THIS PAGE



\* X 8 2 3 7 6 0 1 1 8 \*



9. A pneumatic circuit is needed to feed waste into an incinerator as part of a system to produce electricity from rubbish. For safety reasons, a barrier must be raised before material is pushed in.

The system must also allow both cylinders to be outstroked to allow for maintenance, and must have an emergency feature to immediately close the barrier and withdraw the ram if required.

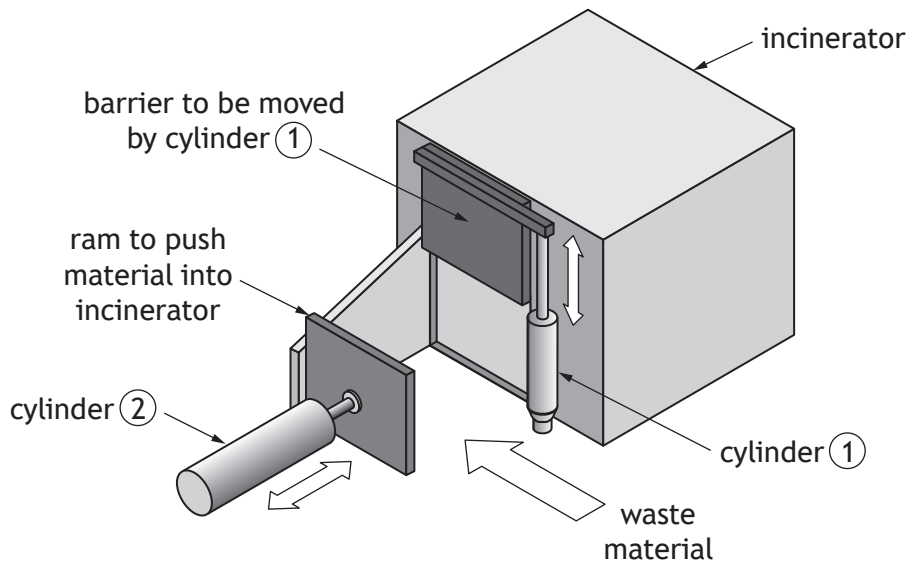

The pneumatic circuit is triggered by the electronic circuit shown below. The relay requires 56 mA ( $I_C$ ) to activate.

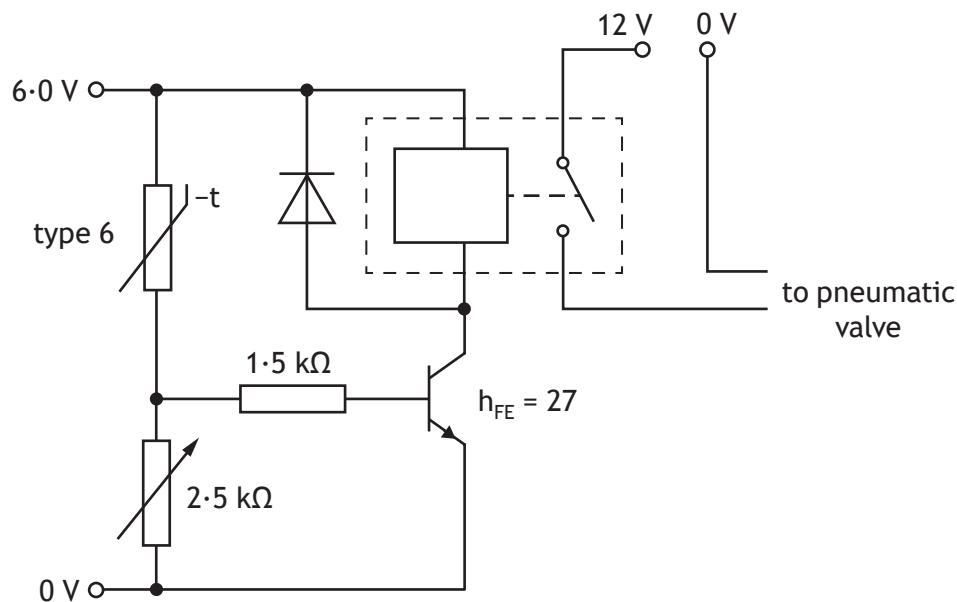

\* X 8 2 3 7 6 0 1 2 0 \*

9. (continued)

- (a) Calculate the minimum base current ( $I_b$ ) required to switch on the relay. 1

- (b) Calculate the voltage required across the variable resistor. 2  
(Assume  $V_{be}$  is 0.7 V)

- (c) Calculate the current through the variable resistor. 1

[Turn over



\* X 8 2 3 7 6 0 1 2 1 \*

9. (continued)

MARKS  
DO NOT WRITE IN THIS MARGIN

At a later point in the testing process  $I_b$  was found to be 1.35 mA, and the current through the variable resistor was 1.09 mA. The variable resistor was still set at 2.5 k $\Omega$ .

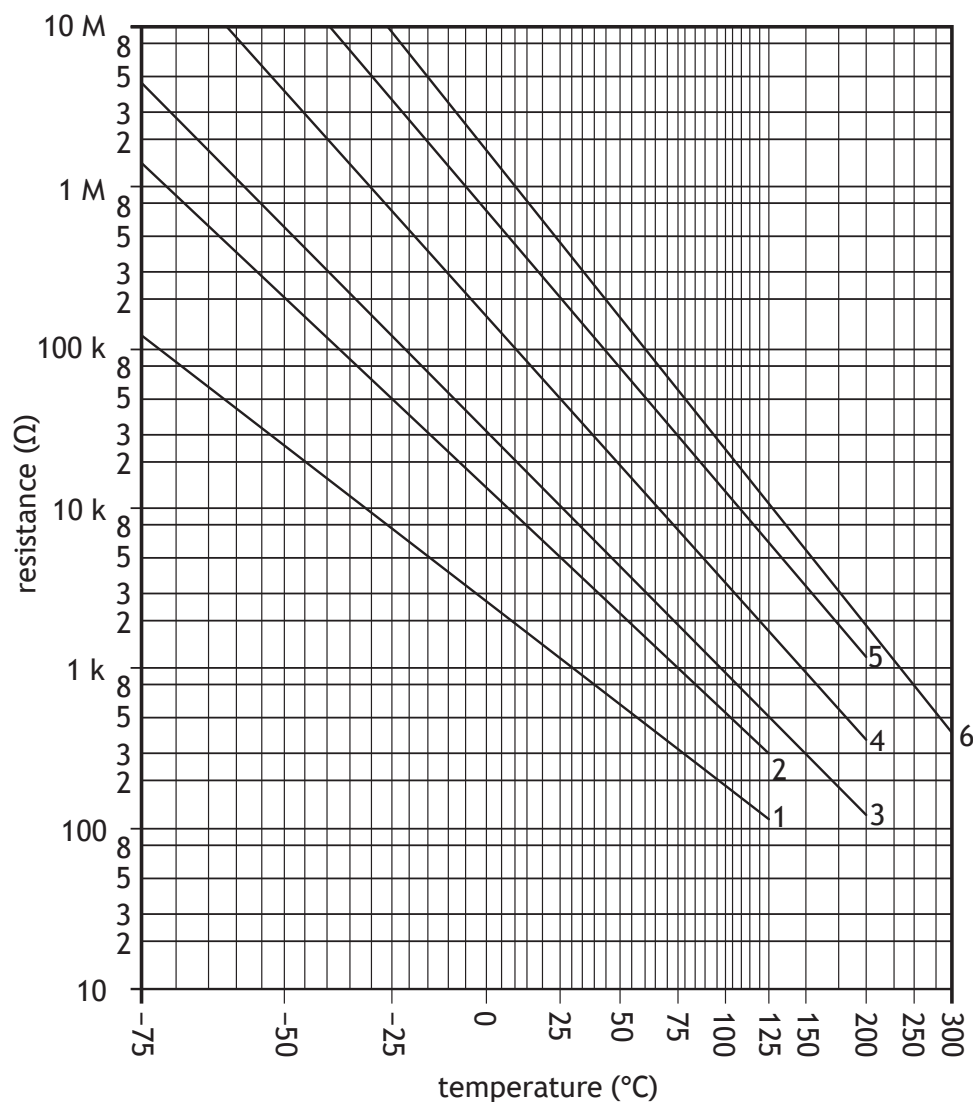

- (d) Calculate the resistance of the type 6 thermistor and, using the graph above, find the temperature of the thermistor.

5



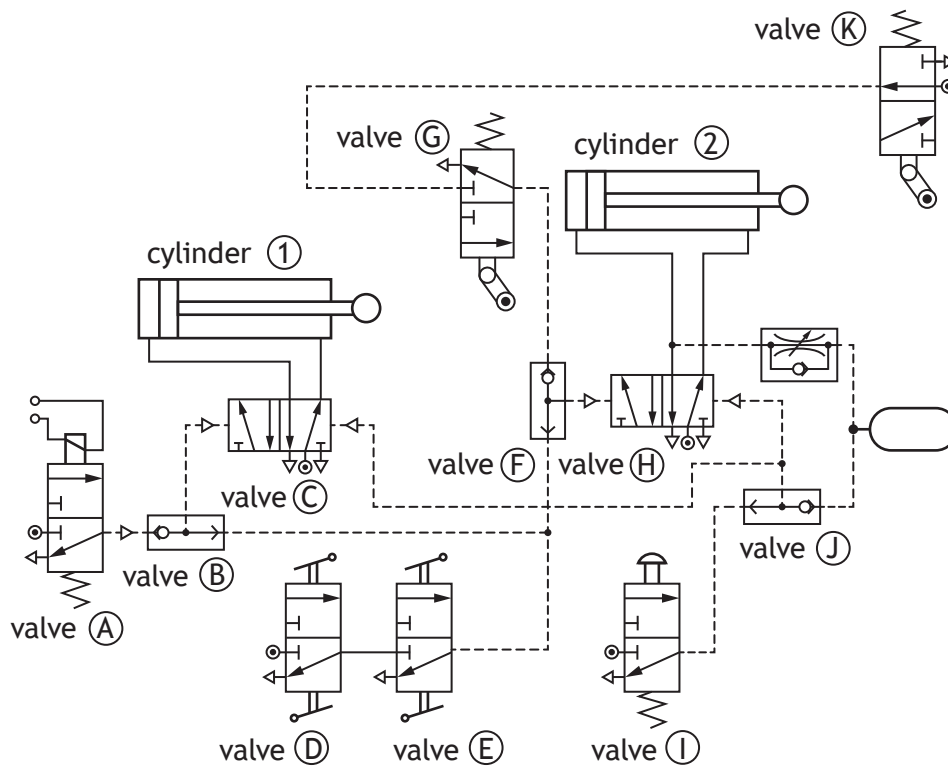

(e) Describe, with reference to the circuit shown above, what happens when valve (A) is actuated by the relay.

6

---

---

---

---

---

---

---

---

---

---

---

---

---

---

---

---

---

---

---

---

---

---

---

---



## 9. (continued)

- (f) Explain, giving two reasons, why using a microcontroller based system with solenoid actuated 5/2 valves controlling the cylinders would be a preferred solution.

2

---

---

---

---

---

---

---



\* X 8 2 3 7 6 0 1 2 4 \*

[Turn over for next question

DO NOT WRITE ON THIS PAGE



\* X 8 2 3 7 6 0 1 2 5 \*

10. An engineering company has designed a railway tunnel for a new rail line through a major city.  
A boring machine is used to excavate the tunnel.

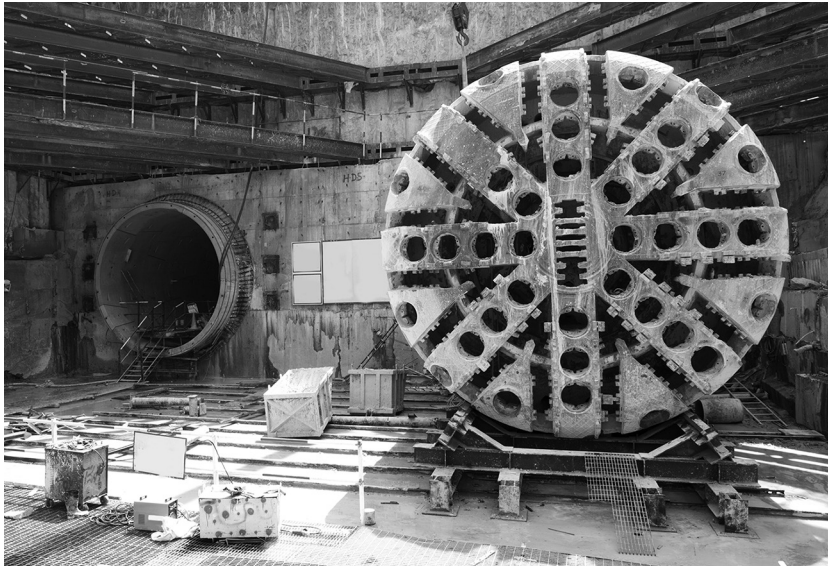

- (a) Civil and environmental engineers play a critical role in all phases of the project.
- (i) Describe two roles of a civil engineer during the planning phase of the project.

2

---

---

---

---

---

---

---

---

---

---



MARKS

DO NOT  
WRITE IN  
THIS  
MARGIN

10. (a) (continued)

(ii) Describe a role of an environmental engineer during the construction phase of the project.

1

---

---

---

---

---

---

---

[Turn over



\* X 8 2 3 7 6 0 1 2 7 \*

10. (continued)

- (b) A second machine with a diameter of 12.4 m follows the boring machine to smooth the surfaces of the tunnel. Three cutting blades, rotating at  $9.93 \text{ revs min}^{-1}$ , are powered by a motor. Each cutting blade exerts a force of 924 N on the rock surface.

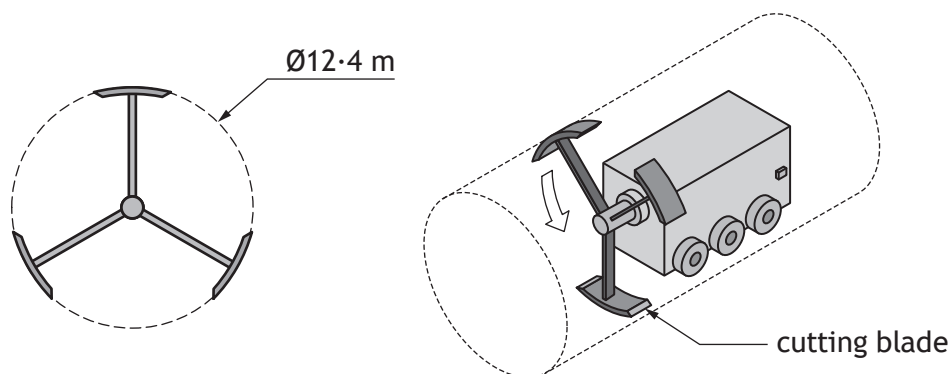

- (i) Calculate the total torque produced by the motor.

2

- (ii) Calculate the output power of the motor.

2



10. (continued)

- (c) The mechanism used to raise and then lower each machine into position requires a range of complex mechanisms, including bearings and a brake.

A ball bearing and a roller bearing are shown below.

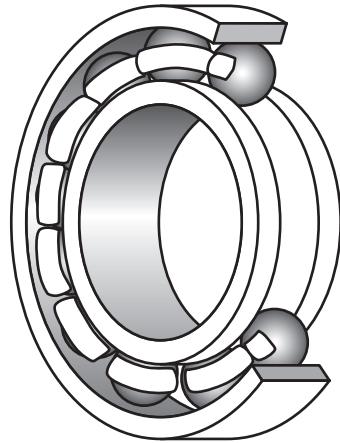

ball bearing

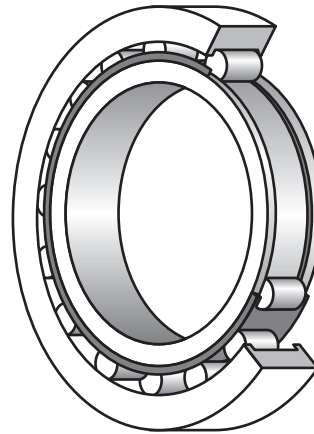

roller bearing

- (i) Describe the purpose of a bearing.

1

---



---



---

- (ii) Describe an advantage of using a roller bearing over a ball bearing, in this situation.

1

---



---



---



---



---

[Turn over



\* X 8 2 3 7 6 0 1 2 9 \*

10. (continued)

The boring machine, with mass 120,000 kg is lowered to a depth of 42.6 m.

The brakes used to control the rate of descent have a mass of 88 kg and a specific heat capacity of  $910 \text{ J kg}^{-1} \text{ K}^{-1}$ . The brake temperature at the start of the operation is  $17 \text{ }^\circ\text{C}$ .

(d) Calculate the final brake temperature.

3

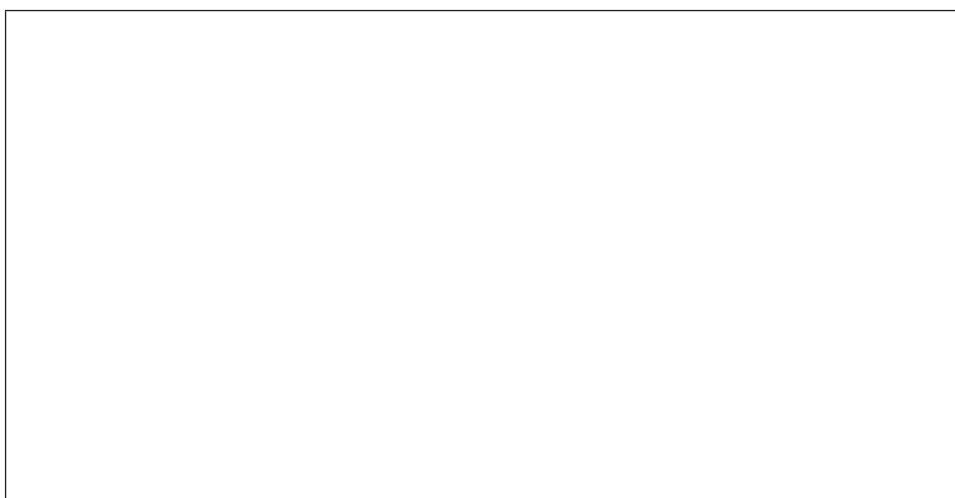

The final design of the structure used to support the weight of the boring machine during the lowering process is shown below.

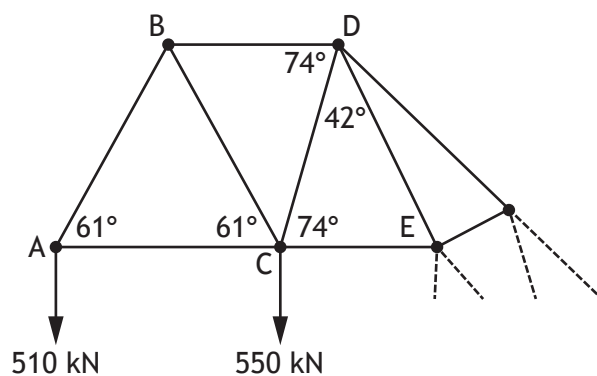

10. (continued)

MARKS

DO NOT  
WRITE IN  
THIS  
MARGIN

6

- (e) Complete, using nodal analysis, the table of the missing forces and their natures.

Member	AB	AC	BC	BD	CD	CE
Force			583 kN	566 kN		
Nature	tie	strut	strut	tie		

*Space for calculations*



\* X 8 2 3 7 6 0 1 3 1 \*

11. The V&A museum is part of the new waterfront project in Dundee. As part of the project, teams of engineers have been working on improvements to Dundee railway station and the road network in the city centre.



- (a) Explain, with reference to two social impacts, why cities make improvements to railway stations and road networks.

4

Impact 1 \_\_\_\_\_

\_\_\_\_\_

\_\_\_\_\_

\_\_\_\_\_

Impact 2 \_\_\_\_\_

\_\_\_\_\_

\_\_\_\_\_

\_\_\_\_\_



\* X 8 2 3 7 6 0 1 3 2 \*

11. (continued)

MARKS  
DO NOT WRITE IN THIS MARGIN

- (b) In the museum, a new exhibit is suspended from the ceiling using cables as shown below.

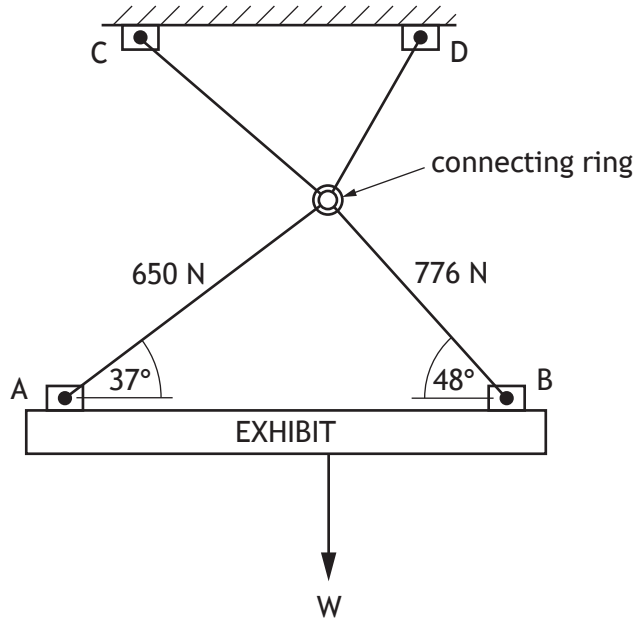

The force  $W$  represents the weight of the exhibit and is acting 1.4 m from point B. The distance from A to B is 3.46 m.

- (i) Draw a free body diagram of the forces acting on the exhibit. 2

- (ii) Calculate the force,  $W$ . 2



11. (continued)

(c) The forces acting on the connecting ring are shown below.

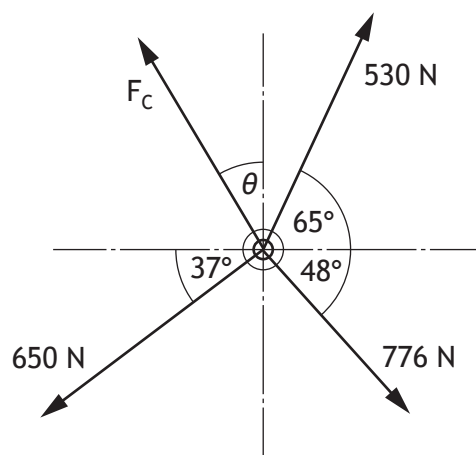

Calculate the magnitude of  $F_c$  and angle  $\theta$ .

6



11. (continued)

- (d) A replacement exhibit is to be suspended from the ceiling in the same position.

The two cables supporting the new exhibit hanging from the connecting ring are replaced with a hollow aluminium alloy tube.

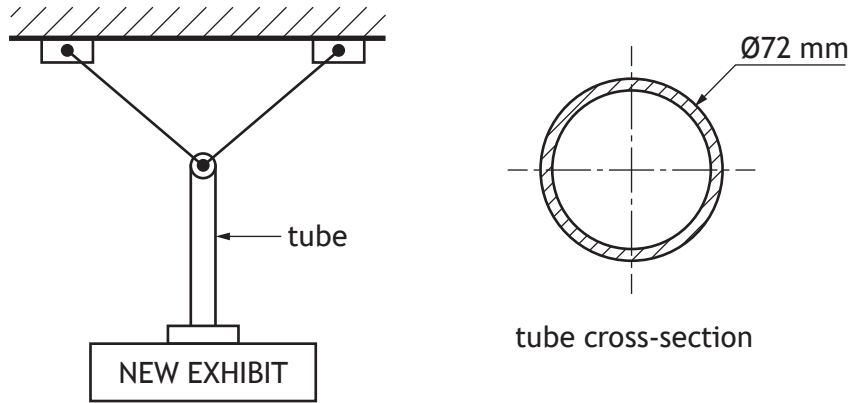

The 2.7 m long tube has a diameter of 72 mm and a wall thickness of 2.5 mm. It supports a load of 32.7 kN.

- (i) Calculate the change in length of the tube when it is loaded with the new exhibit.

6



MARKS

DO NOT  
WRITE IN  
THIS  
MARGIN

11. (d) (continued)

- (ii) State two changes that could be made to the tube to increase the factor of safety.

2

---

---

---

---

[END OF QUESTION PAPER]



\* X 8 2 3 7 6 0 1 3 6 \*

MARKS

DO NOT  
WRITE IN  
THIS  
MARGIN

ADDITIONAL SPACE FOR ANSWERS



\* X 8 2 3 7 6 0 1 3 7 \*

MARKS

DO NOT  
WRITE IN  
THIS  
MARGIN

ADDITIONAL SPACE FOR ANSWERS



\* X 8 2 3 7 6 0 1 3 8 \*

[BLANK PAGE]

DO NOT WRITE ON THIS PAGE



\* X 8 2 3 7 6 0 1 3 9 \*

[BLANK PAGE]

DO NOT WRITE ON THIS PAGE

*Acknowledgement of copyright*

- Question 4 Gas tanker: Oleksandr Kalinichenko/shutterstock.com  
Question 5 Mini fridge: AnEduard/shutterstock.com  
Question 10 Tunnel machine: PI/shutterstock.com  
Question 11 V&A Dundee: Joe Dailly/shutterstock.com



\* X 8 2 3 7 6 0 1 4 0 \*