

FOR OFFICIAL USE



--	--	--	--	--	--

National
Qualifications
2022

Mark

--

X823/76/01

Engineering Science

WEDNESDAY, 18 MAY

1:00 PM – 3:30 PM



* X 8 2 3 7 6 0 1 *

Fill in these boxes and read what is printed below.

Full name of centre

--

Town

--

Forename(s)

--

Surname

--

Number of seat

--

Date of birth

Day

--	--

Month

--	--

Year

--	--

Scottish candidate number

--	--	--	--	--	--	--	--	--	--

Total marks — 110

SECTION 1 — 20 marks

Attempt ALL questions.

SECTION 2 — 90 marks

Attempt ALL questions.

Show all working and units where appropriate.

You should refer to the Higher Engineering Science Data Booklet which you have been given. The number of significant figures expressed in a final answer should be equivalent to the least significant data value given in the question. Answers that have two more figures or one less figure than this will be accepted.

Write your answers clearly in the spaces provided in this booklet. Additional space for answers is provided at the end of this booklet. If you use this space you must clearly identify the question number you are attempting.

Use **blue** or **black** ink.

Before leaving the examination room you must give this booklet to the Invigilator; if you do not, you may lose all the marks for this paper.



* X 8 2 3 7 6 0 1 0 1 *

SECTION 1 — 20 marks

Attempt ALL questions

1. A new material is being tested for use in the manufacture of ships.



The results of a tensile test on the material are shown in Figure 1.

The range of 0 to A is shown magnified in Figure 2.

Figure 1

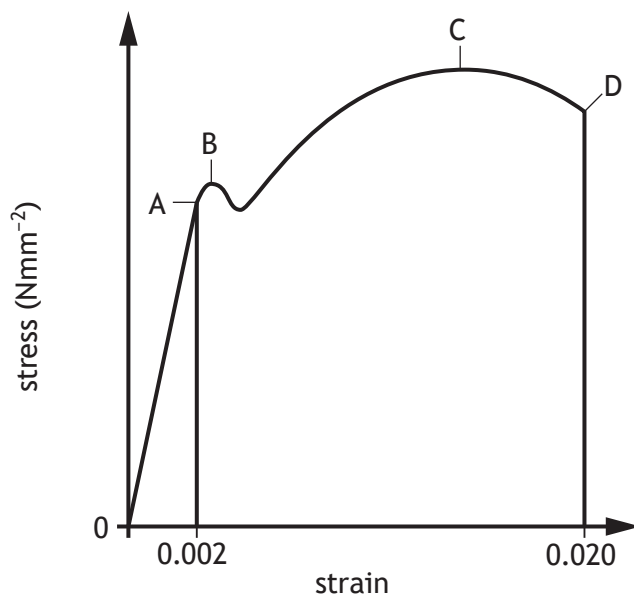
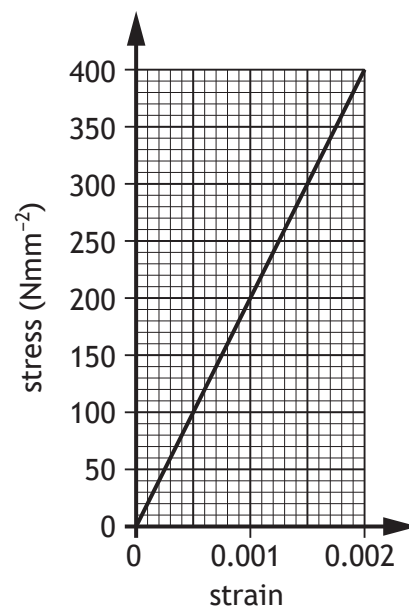

Figure 2



* X 8 2 3 7 6 0 1 0 2 *

1. (continued)

(a) (i) State the name of the range 0 to A.

1

(ii) State the name of the range A to D.

1

(b) (i) Calculate, using the information from **Figure 2**, Young's Modulus for this material.

1

(ii) State the property identified by point C on **Figure 1**.

1

[Turn over



2. Part of an electronic circuit is shown.

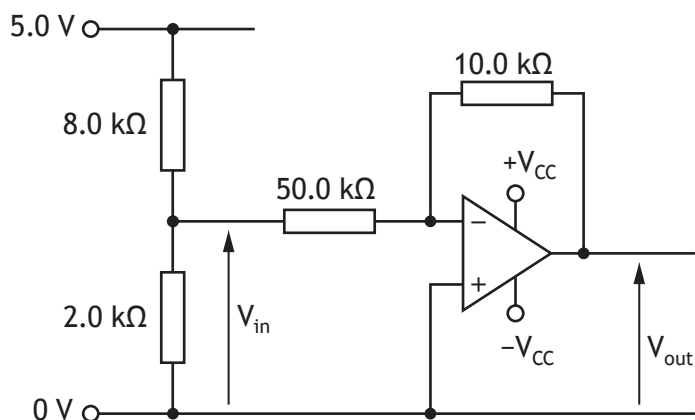

(a) Calculate V_{out} .

2

(b) Describe how the gain of this op-amp circuit could be decreased.

1

After testing, it was decided to add an additional op-amp configuration to change the polarity of V_{out} .

(c) State the name of the op-amp configuration required to perform this task.

1



3. A beam used in the construction of a covered walkway is shown.

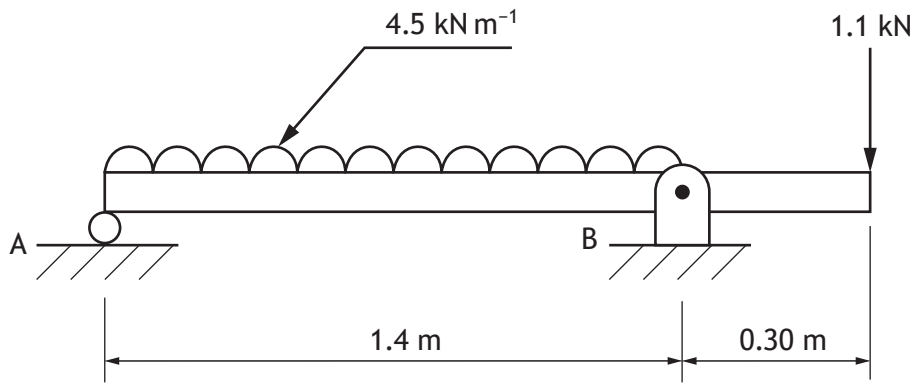

Calculate by taking moments about B, the vertical reaction at A.

3



4. The speed at which an automatic garage door opens is controlled by a motor using pulse-width modulation (PWM).



- (a) Complete the graph below to show how PWM could be used to make the motor rotate at half speed.

You should include at least three pulses.

2

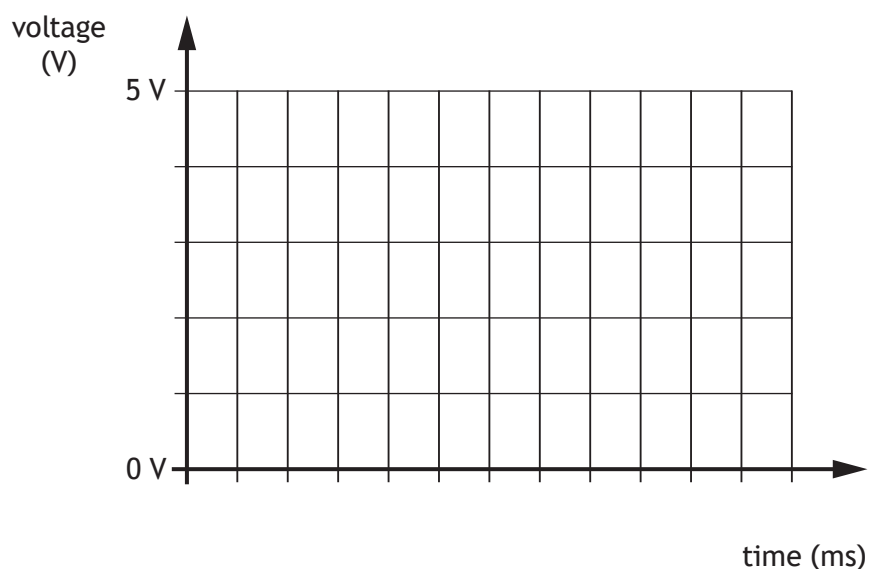

- (b) Describe how the speed of this motor could be decreased using PWM.

1



4. (continued)

An alternative method of speed control involves varying the size of the DC voltage supplied to the motor.

- (c) Describe one advantage of using PWM in comparison to varying the size of the voltage supply.

1

[Turn over



* X 8 2 3 7 6 0 1 0 7 *

5. The capacity of a sports stadium is being increased. This needs an additional stand to be built on top of the existing structure.

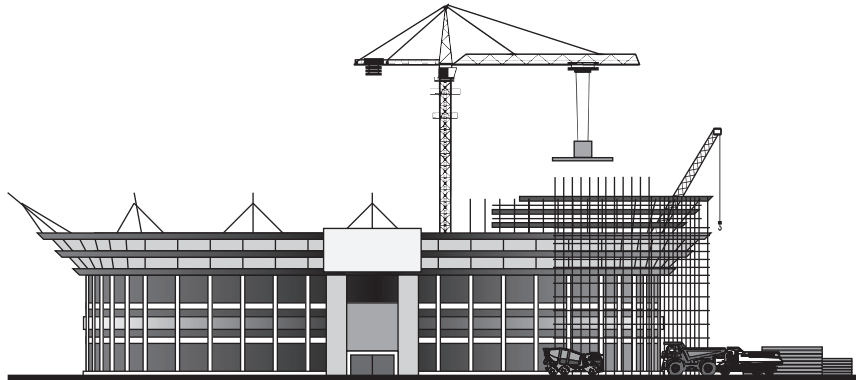

A structural engineer is involved in the design of this new structure.

Describe two examples of how the structural engineer will use their knowledge of materials in the design of the new structure.

2

Example 1 _____

Example 2 _____



6. An electronic engineer has designed a combinational logic circuit according to the Boolean equation, shown below.

$$Z = (\overline{A \cdot B}) \cdot (C + D)$$

Draw a NAND equivalent circuit for this Boolean equation.

3

Space for working

Final answer

A

B

C

D



* X 8 2 3 7 6 0 1 0 9 *

SECTION 2 — 90 marks

Attempt ALL questions

7. An engineering team has produced a prototype system to store excess energy from power plants.

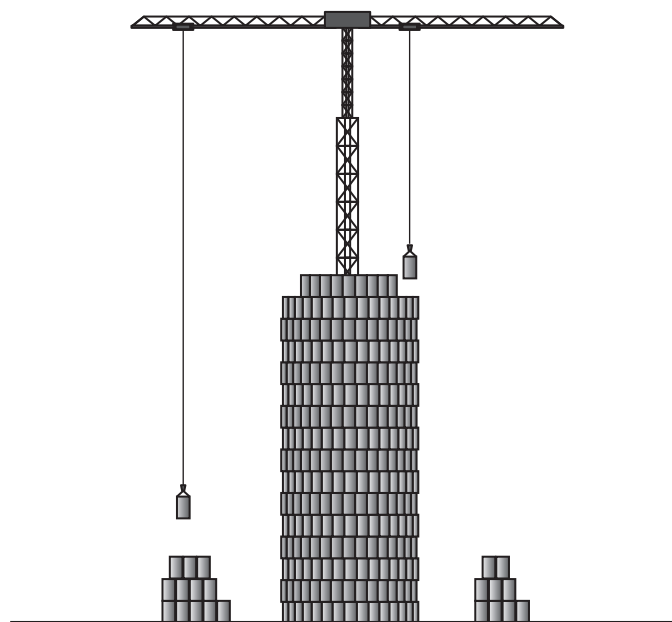

When electricity production exceeds demand, electric motors are used to lift concrete blocks and place them in ‘towers’. When the blocks are returned to ground level electricity is reclaimed by generators.

The first block has a mass of 10,000.0 kg. The system that raises this block is 92% efficient.

- (a) Calculate the energy required to raise this block 32 m.

2



7. (continued)

A second block applies a force of 80.0 kN to the supporting wire rope.

As this block is returned to ground level (at constant speed) its supporting wire rope turns a generator and electricity is reclaimed. This part of the system is 87% efficient.

- (b) Calculate the power output from the generator if this block descends 15 m in 11 seconds.

3

The wire rope holding the 80.0 kN block as it is lifted is made from mild steel and has a diameter of 48 mm.

- (c) Calculate the factor of safety in the wire rope when it raises this block at a steady speed.

4



7. (continued)

MARKS
DO NOT
WRITE IN
THIS
MARGIN

- (d) Describe two economic and two environmental impacts that this system would have.

4

Economic impact 1 _____

Economic impact 2 _____

Environmental impact 1 _____

Environmental impact 2 _____

- (e) Describe two advantages that this system has over a chemical battery storage system for excess electrical energy.

2

Advantage 1 _____

Advantage 2 _____



* X 8 2 3 7 6 0 1 1 2 *

[Turn over for next question

DO NOT WRITE ON THIS PAGE



* X 8 2 3 7 6 0 1 1 3 *

8. An anti-lock braking system is used to control the speed of an elevator as it descends. This uses a form of pulse-width modulation operated by a microcontroller.

If the speed of the elevator is too fast, the brakes will increase the proportion of operating time.

The table below identifies the connections to the microcontroller.

Input	Pin	Output
	7	brake
ground level sensor	1	
speed sensor (analogue)	0	

The system must perform the following steps.

- Values for **mark** and **space** both need to be initially set to a value of 100
- A reading must be taken from a speed sensor and its value stored in variable X
- If the value of X is greater than 128 then **mark** increases by 1 and **space** decreases by 1
- If the value of X is smaller than 128 then **mark** decreases by 1 and **space** increases by 1
- If the value of X is 128 then **mark** and **space** do not change
- The brake must be switched on and off for the times specified **mark** and **space** (this will be in milliseconds)
- The process must continue until the ground level sensor is activated



8. (continued)

- (a) Complete, with reference to the specification and the input/output table, this flow chart for the control of the system.

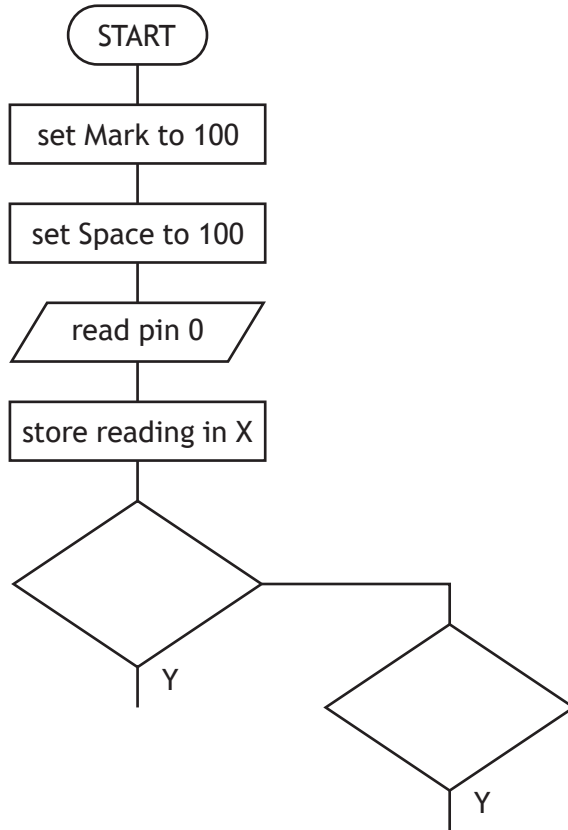

8. (continued)

An alarm (Z) is part of the elevator's operating system and needs to be activated under the conditions given by the following Boolean equation.

$$Z = \bar{A} \cdot (B + C)$$

(b) Complete the following flowchart to perform the function described above.

3

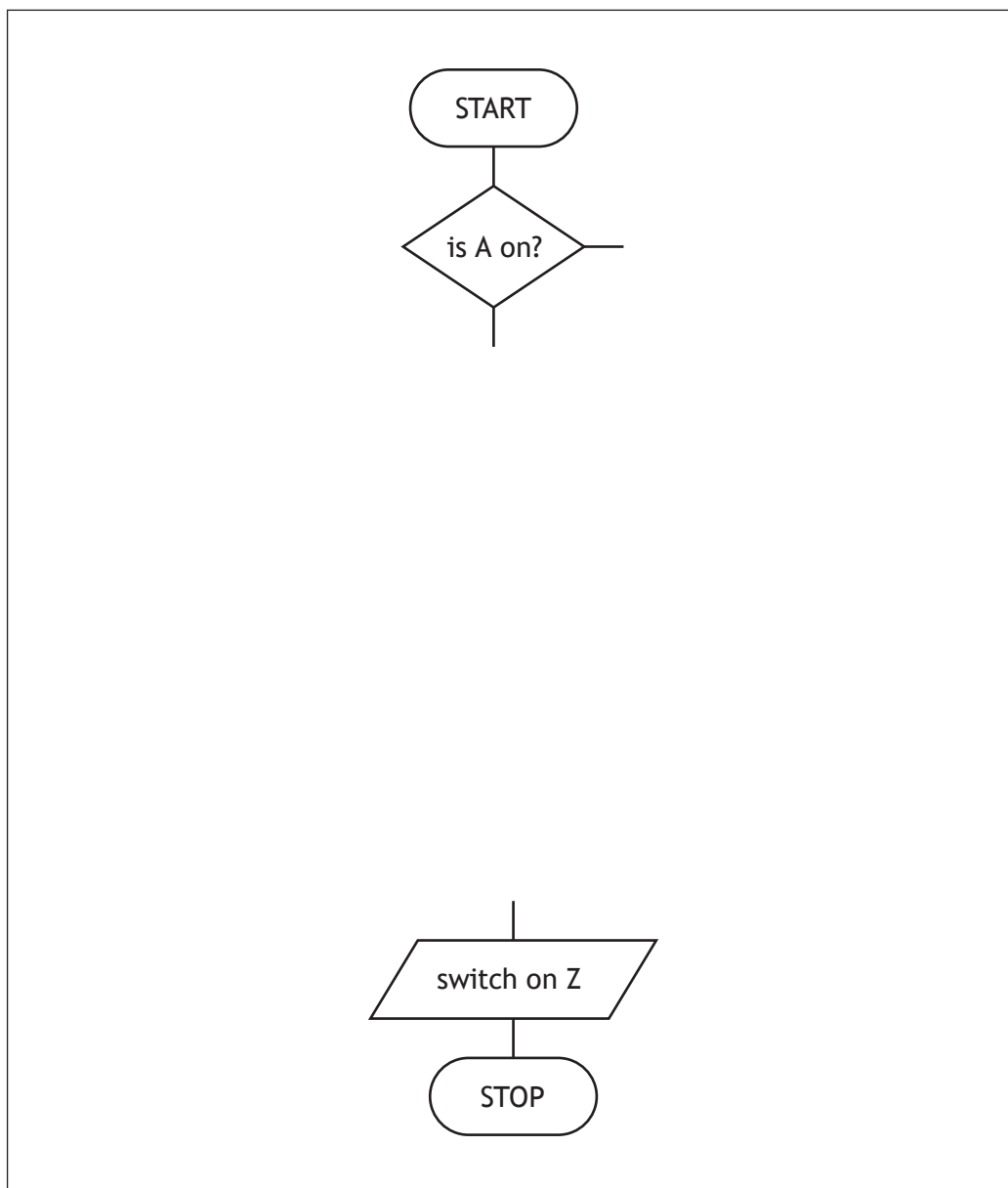

[Turn over for next question

DO NOT WRITE ON THIS PAGE



* X 8 2 3 7 6 0 1 1 7 *

8. (continued)

An alternative system to control the force applied by the brake is also tested. As the speed of the elevator varies from a reference value the output of the circuit changes proportionately. The speed of the elevator is monitored by a tachogenerator.

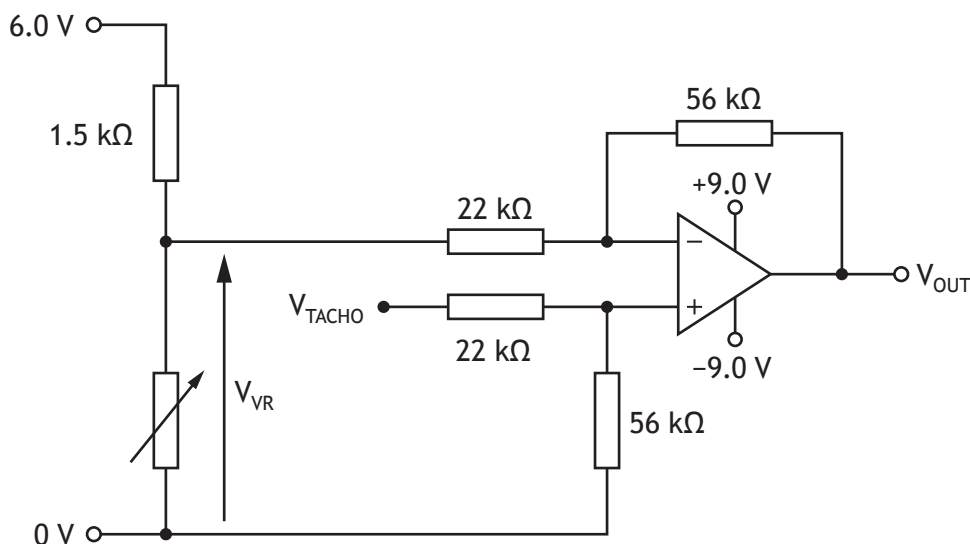

When testing the circuit, the voltage from the tachogenerator (V_{TACHO}) was found to be 2.3 V.

- (c) (i) Calculate the resistance of the variable resistor in the circuit shown above when the output voltage of the op-amp is +4.5 V.

4



8. (c) (continued)

(ii) Describe, with reference to the circuit, how the reference speed of the elevator could be increased.

1

[Turn over



* X 8 2 3 7 6 0 1 1 9 *

9. A system is needed to alter the position of a solar panel so that it is constantly facing the sun during daylight hours. If one sensor gives a higher reading than the other, a motor will turn the panel in the brighter direction.



A preliminary design of the control circuit is shown below.

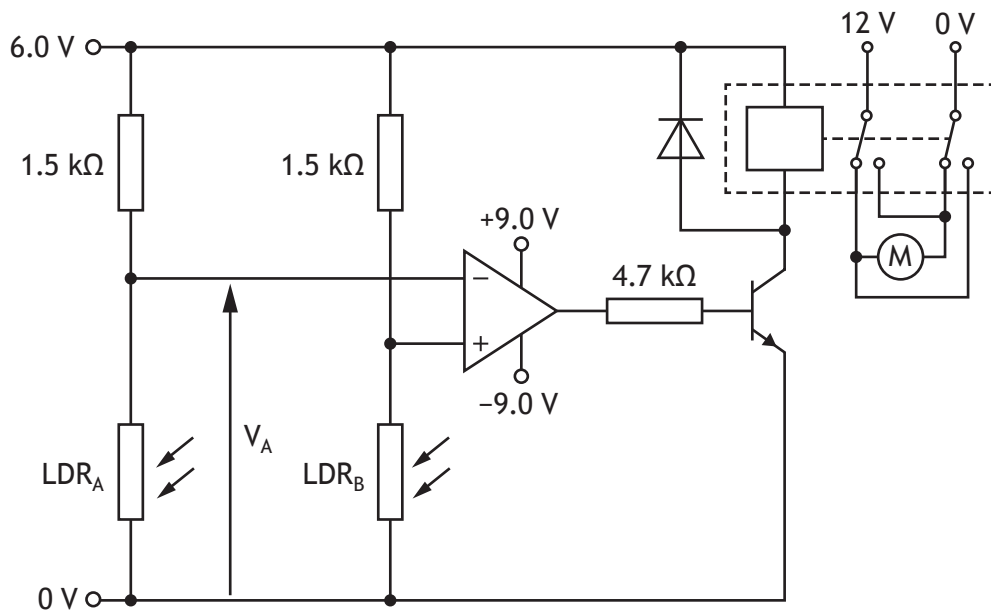

* X 8 2 3 7 6 0 1 2 0 *

9. (continued)

The characteristics of the LDRs are shown in the graph below.

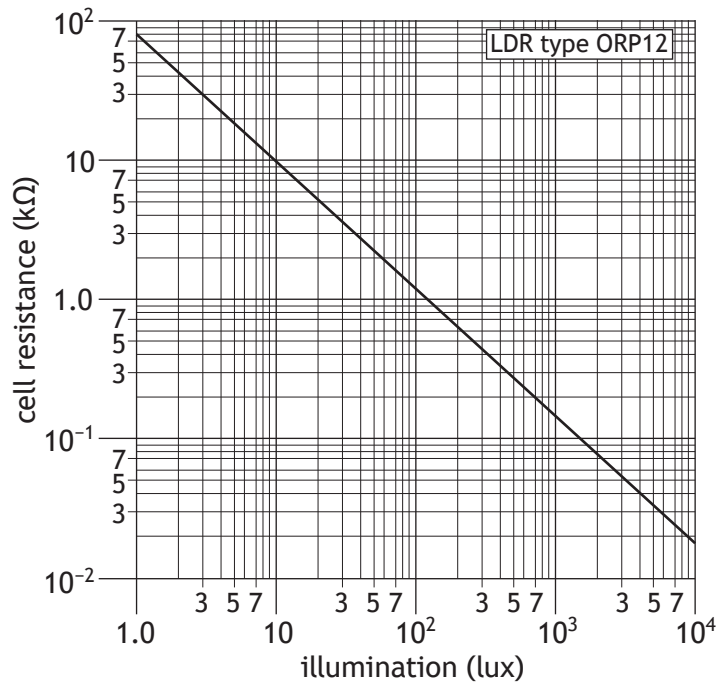

(a) Calculate V_A if the light level on LDR_A is 20 lux.

2



9. (continued)

Part of the control circuit is shown below.

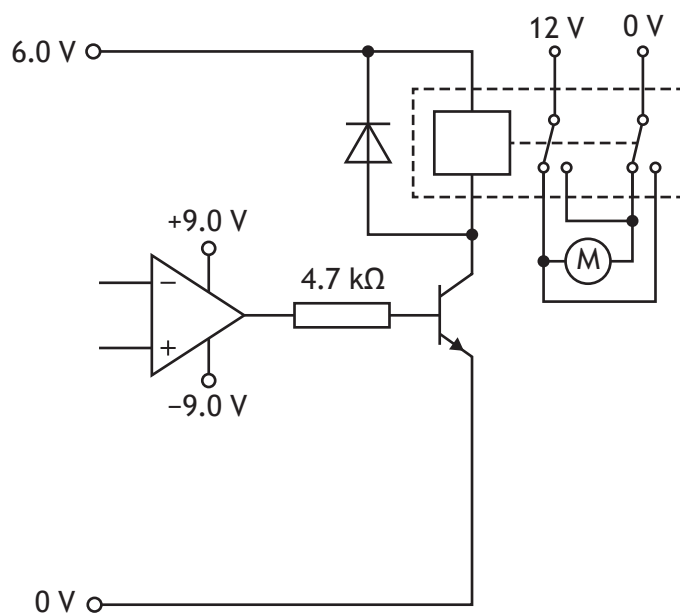

- (b) (i) Calculate the base current to the transistor when the op-amp saturates positively.
 Assume V_{be} is 0.70 V. The op-amp output saturates at 75% of the supply voltage.

3



9. (b) (continued)

The relay has a resistance of 5.0Ω .

- (ii) Calculate the minimum current gain of the transistor to ensure it is fully saturated when the op-amp is saturated positively.

2

[Turn over



9. (continued)

While testing the circuit, V_A was found to be less than V_B and the motor rotated, moving the solar panel towards the sun's position.

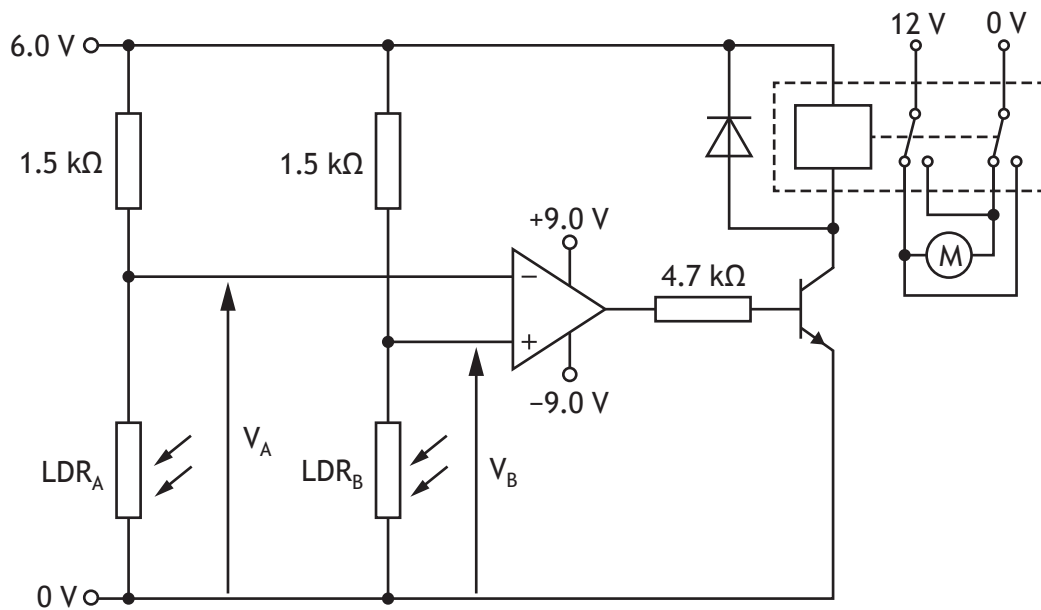
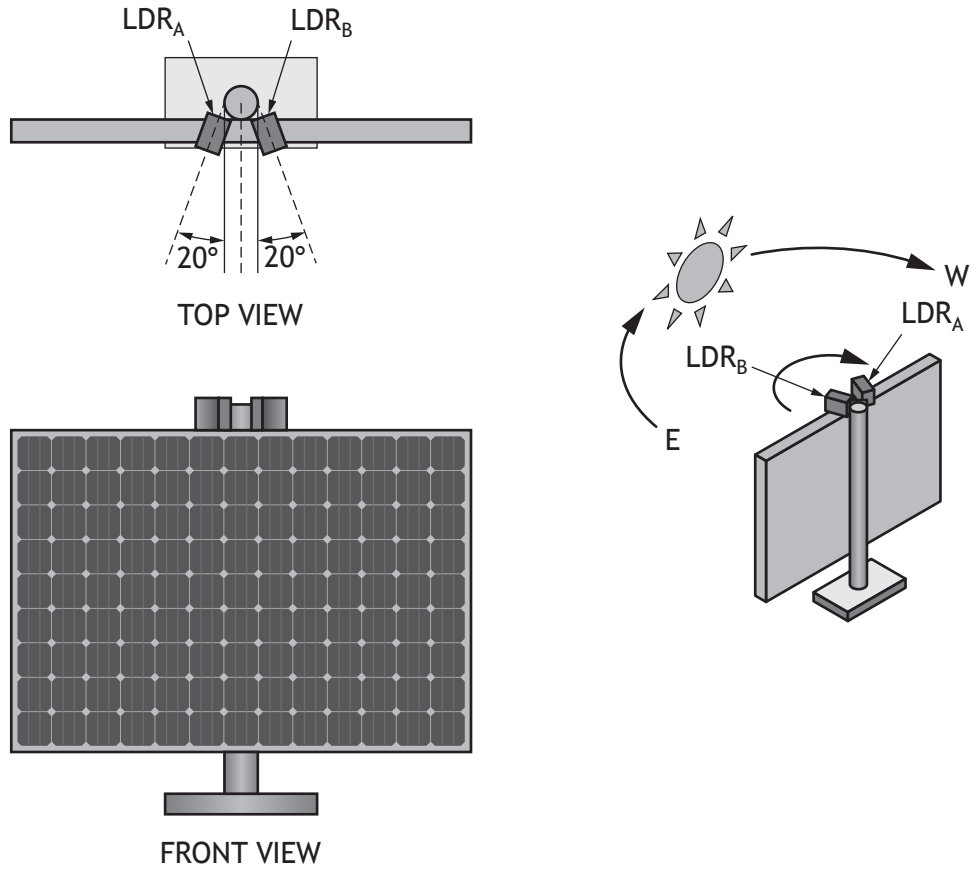

9. (continued)

- (c) Describe, referring to the circuit on the opposite page, what will happen as the solar panel moves.

Your answer must refer to the input voltage dividers, the op-amp and transistor, and the relay and motor.

6

Input voltage dividers _____

Op-amp and transistor _____

Relay and motor _____

[Turn over



9. (continued)

The op-amp control circuit uses two-state control.

- (d) (i) Complete the graph below to show how the output of a two-state control system changes as it approaches the desired output.

2

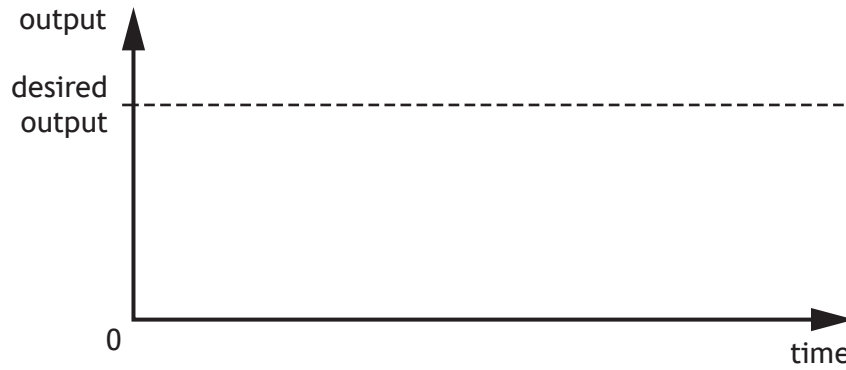

- (ii) Describe the impact that this type of control would have on the mechanical output of the system.

1



9. (continued)

An alternative control circuit is also tested.

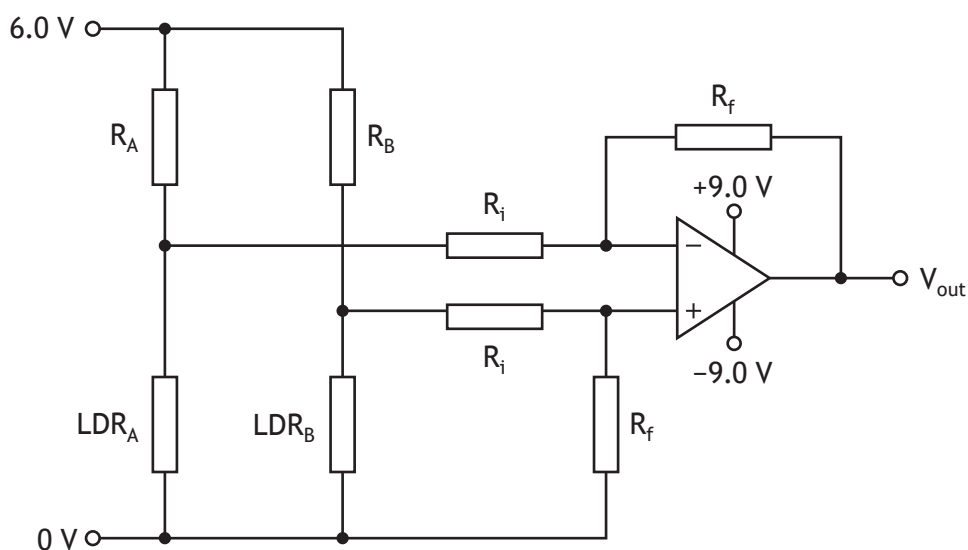

- (e) (i) State the type of control produced by this type of circuit.

1

- (ii) Describe the difference between the control produced by this circuit and a two-state control system. You can use diagrams or graphs to illustrate your answer.

3

[Turn over



10. An engineering team is experimenting with different control systems to operate a number of pneumatic cylinders. The following truth table shows the conditions under which one of the cylinders must outstroke.

A	B	C	D	Z
0	0	0	0	0
0	0	0	1	0
0	0	1	0	1
0	0	1	1	0
0	1	0	0	0
0	1	0	1	0
0	1	1	0	0
0	1	1	1	0
1	0	0	0	0
1	0	0	1	0
1	0	1	0	1
1	0	1	1	0
1	1	0	0	0
1	1	0	1	0
1	1	1	0	1
1	1	1	1	1

- (a) Write a Boolean equation for the output Z.

2

Z = _____



10. (continued)

A second cylinder operates under the following conditions.

$$X = \bar{A} \cdot B \oplus (\bar{C} \cdot D)$$

(b) Draw a logic diagram to perform this function.

4

[Turn over



10. (continued)

Two further cylinders are to be controlled by the following circuit.

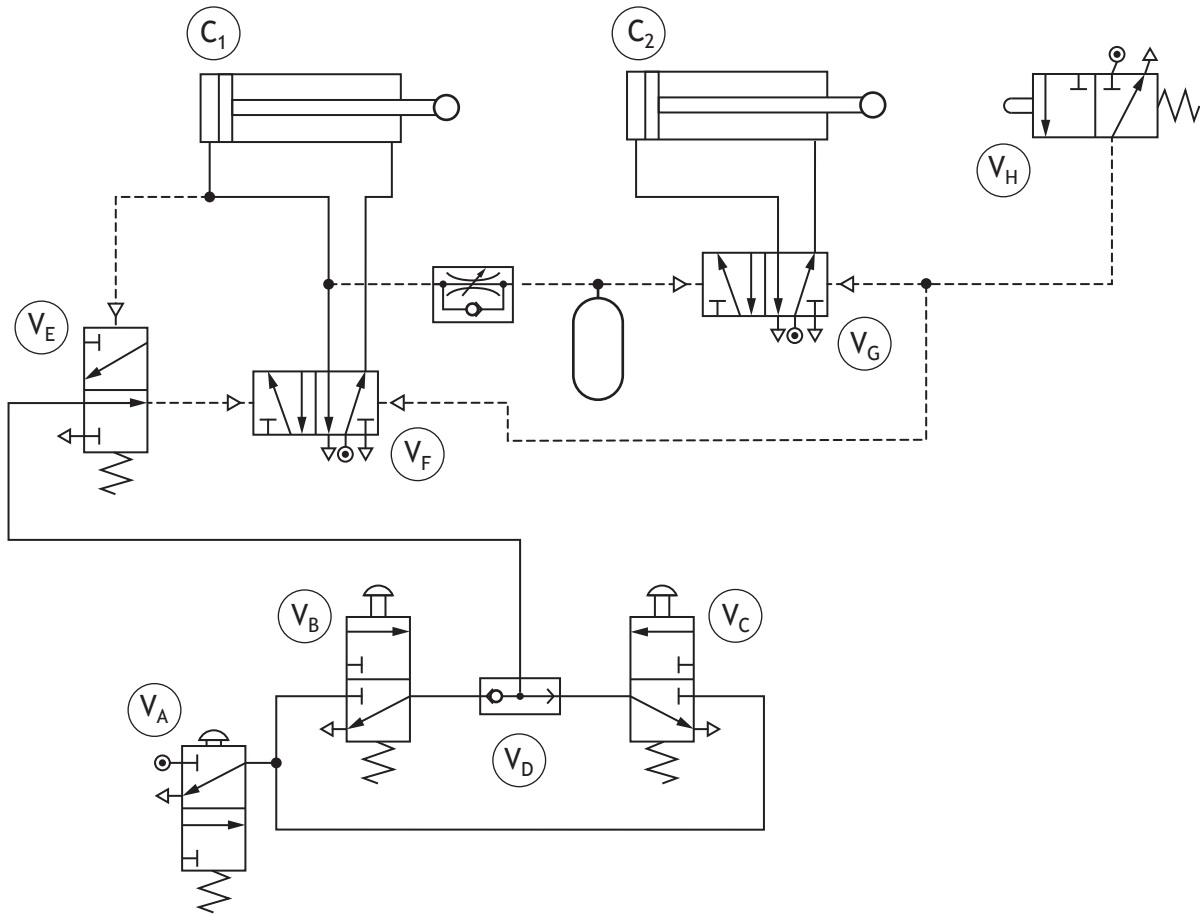

* X 8 2 3 7 6 0 1 3 0 *

10. (continued)

- (c) (i) Describe the operation of this circuit, highlighting the function of each component and the conditions that will cause the cylinders to instroke and outstroke.

6

When $V_A \dots$ _____

The engineering team are considering changing the circuit shown opposite to one that is operated by a microcontroller.

- (ii) Describe two reasons why using a microcontroller-based system is preferred to a fully pneumatic system.

2



10. (continued)

In order to use a microcontroller-based system, solenoid valves need to be used. The following circuit has been designed to actuate one of the solenoids.

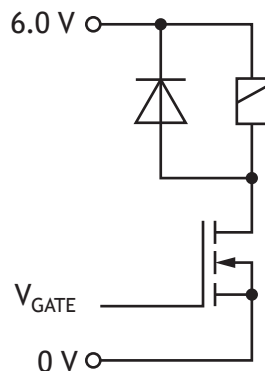

The solenoid is rated 12 W at 6.0 V. The MOSFET has a resistance of 0.70Ω when switched on.

- (d) (i) Calculate the resistance of the solenoid.

1

- (ii) Calculate the current through the MOSFET when it is fully switched on.

1



11. During a construction project in a city centre location, a lifting platform is installed between two high rise buildings.

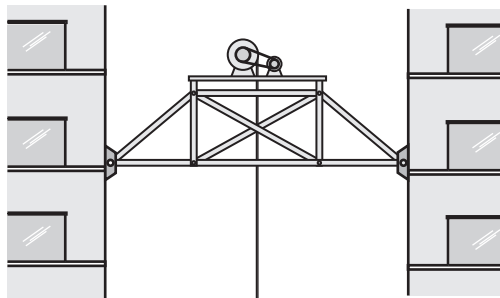

One of the members in the structure has a cross-section as shown below, with an internal diameter of 31 mm, and an external diameter of 36 mm.

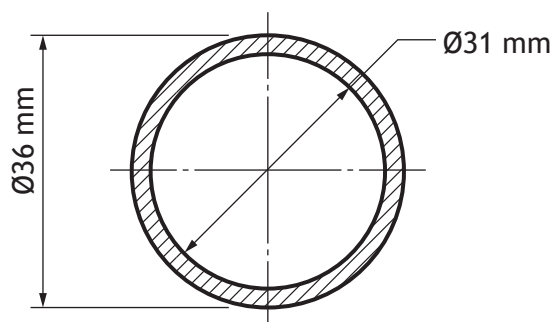

This mild steel member has a strain of 4.6×10^{-5} when subjected to a load.

- (a) Calculate the load carried by this member.

4



11. (continued)

A motor-driven winch system is used for lifting construction materials with up to 12,000 kg of mass. The windlass, with 320 mm diameter, rotates at 12 revolutions per minute.

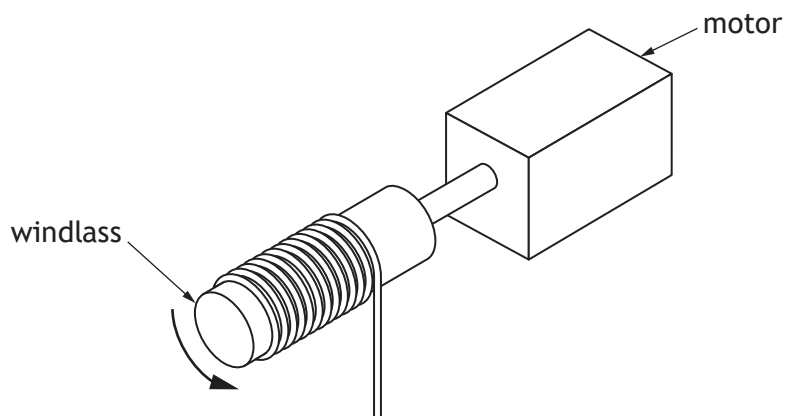

(b) Calculate the mechanical power required by this motor.

5



11. (continued)

Later in the construction project, the lifting platform supports cables used to suspend a concrete beam above the site until it is ready for positioning.

The diagram below represents the concurrent force system while the beam is in suspension.

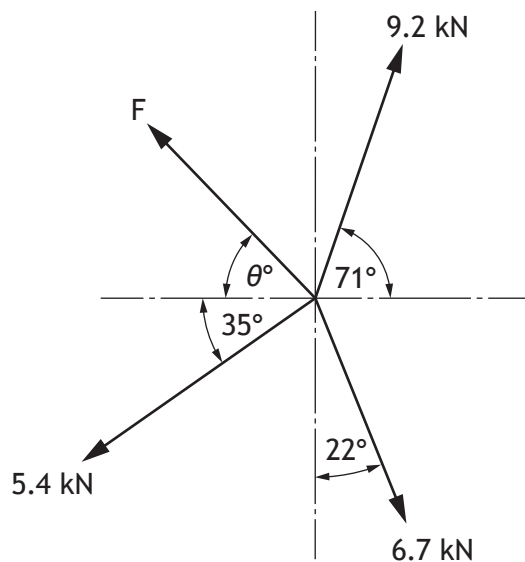

- (c) Calculate the magnitude and angle of the force F , required to maintain equilibrium.

6



12. The free-body diagram for part of a structure and its loading is shown below.

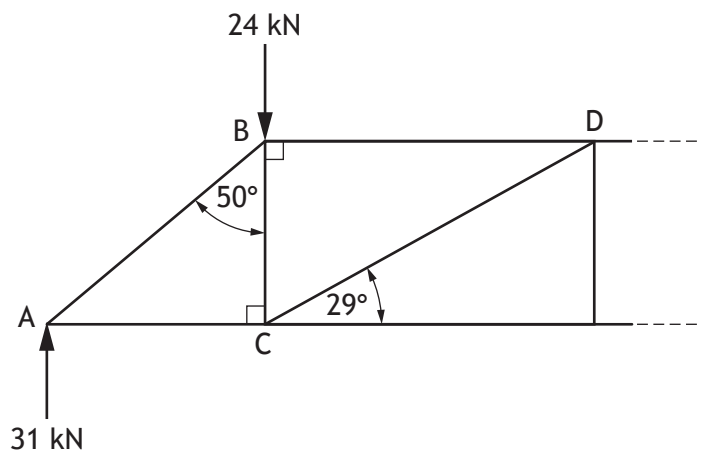

Calculate, using nodal analysis, the magnitude and nature of forces in members AB, AC, BC, BD and CD.

Show all working and final units on the page opposite.

Complete the table below.

8

Member	Magnitude	Nature
AB		strut
AC		tie
BC		
BD		
CD		



12. (continued)

Space for working

node A

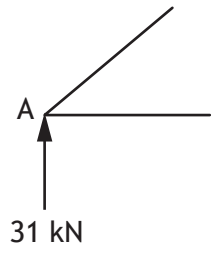

node B

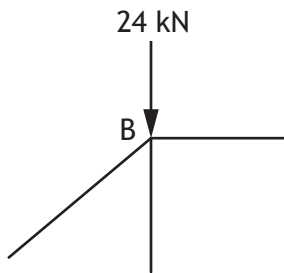

node C

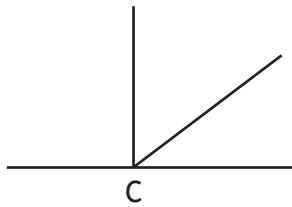

[END OF QUESTION PAPER]



MARKS DO NOT
WRITE IN
THIS
MARGIN

ADDITIONAL SPACE FOR ANSWERS



* X 8 2 3 7 6 0 1 3 8 *

MARKS DO NOT
WRITE IN
THIS
MARGIN

ADDITIONAL SPACE FOR ANSWERS



* X 8 2 3 7 6 0 1 3 9 *

[BLANK PAGE]

DO NOT WRITE ON THIS PAGE

Acknowledgement of copyright

Question 1 Nightman1965/shutterstock.com

Question 4 Volkova Vera/shutterstock.com

Question 9 gui jun peng/shutterstock.com



* X 8 2 3 7 6 0 1 4 0 *