

FOR OFFICIAL USE



--	--	--	--	--	--

National  
Qualifications  
2023

Mark

--

**X823/76/01**

**Engineering Science**

TUESDAY, 16 MAY

1:00 PM – 3:30 PM



\* X 8 2 3 7 6 0 1 \*

Fill in these boxes and read what is printed below.

Full name of centre

--

Town

--

Forename(s)

--

Surname

--

Number of seat

--

Date of birth

Day

--	--

Month

--	--

Year

--	--

Scottish candidate number

--	--	--	--	--	--	--	--	--	--

**Total marks — 110**

**SECTION 1 — 20 marks**

Attempt ALL questions.

**SECTION 2 — 90 marks**

Attempt ALL questions.

**Show all working and units where appropriate.**

You should refer to the Higher Engineering Science Data Booklet which you have been given. The number of significant figures expressed in a final answer should be equivalent to the least significant data value given in the question. Answers that have two more figures or one less figure than this will be accepted.

Write your answers clearly in the spaces provided in this booklet. Additional space for answers is provided at the end of this booklet. If you use this space you must clearly identify the question number you are attempting.

Use **blue** or **black** ink.

Before leaving the examination room you must give this booklet to the Invigilator; if you do not, you may lose all the marks for this paper.



\* X 8 2 3 7 6 0 1 0 1 \*

SECTION 1 — 20 marks

Attempt ALL questions

1. An electronic engineer designs a digital logic circuit for the Boolean equation given below.

$$Z = (\overline{A \cdot B}) + (\overline{C} \cdot D)$$

Draw the digital logic circuit for this Boolean equation.

3

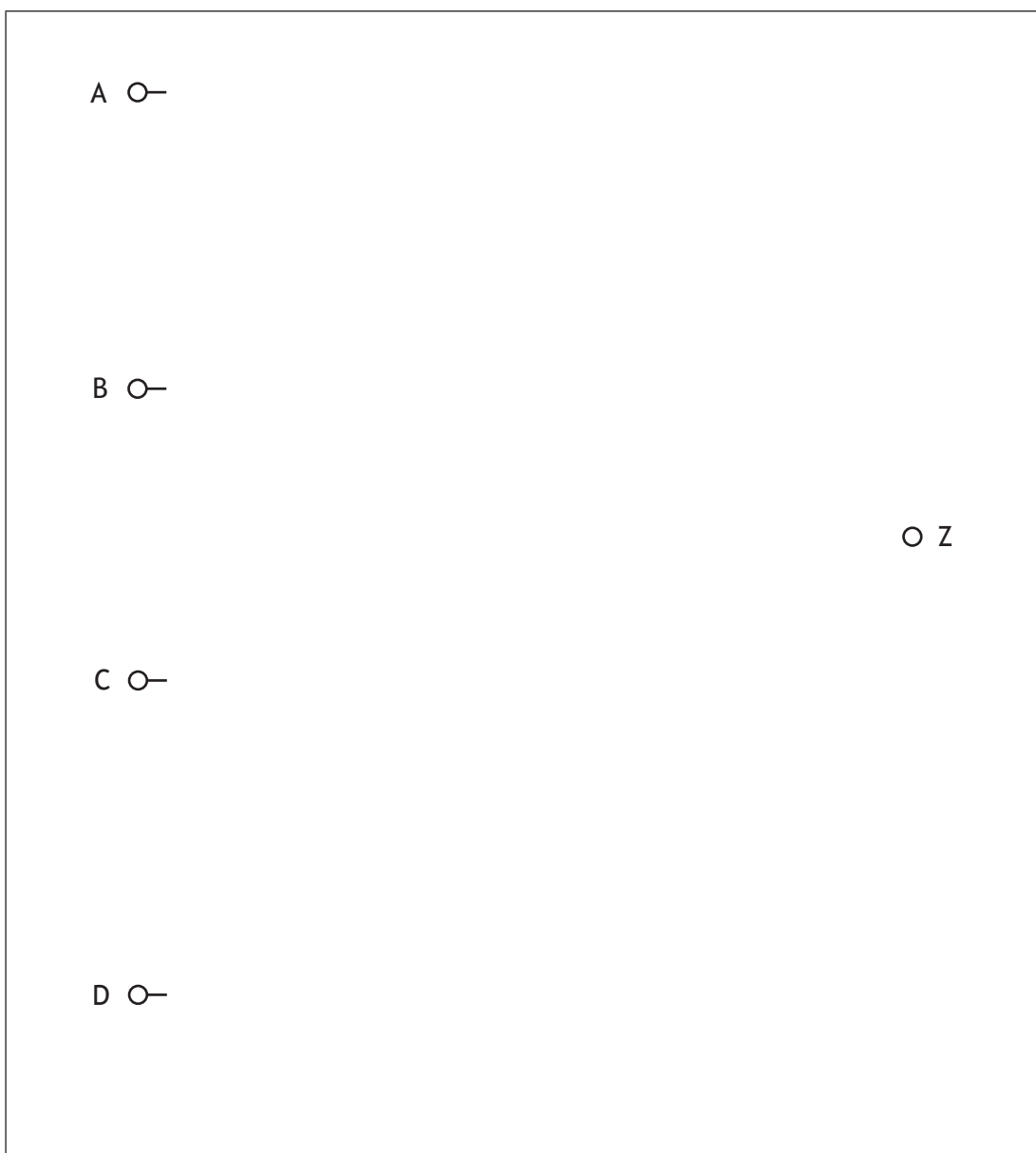

2. A design for an operational amplifier (op-amp) circuit is shown below.

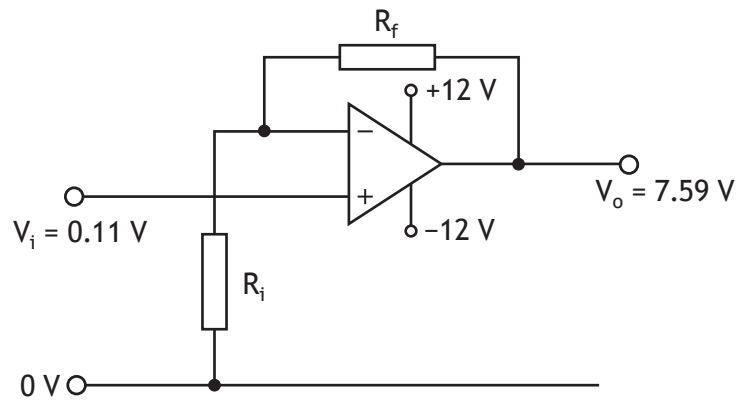

(a) Calculate the gain for this circuit when the input voltage is 0.11 V.

1

(b) Determine appropriate resistor values for  $R_i$  and  $R_f$ .

2



3. In a popular garden game, a tennis ball attached to a pole by a length of rope is hit with a racquet to swing around for another player to hit back.

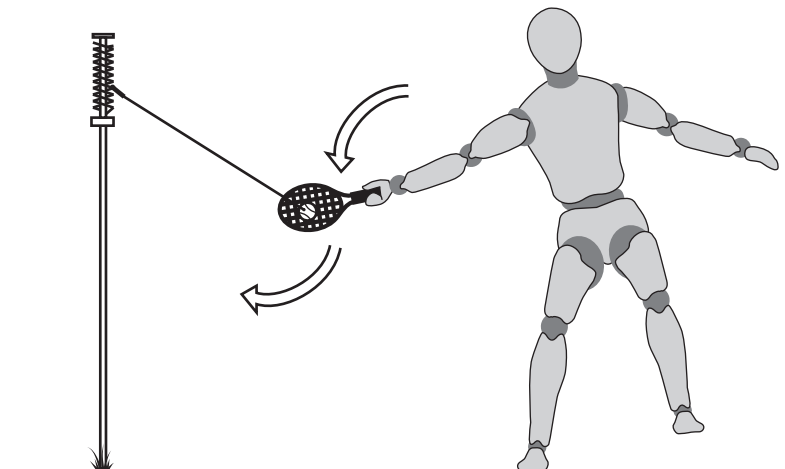

One player has an arm length of 0.84 m and the ball hits the racquet at a further distance of 0.34 m as shown below.

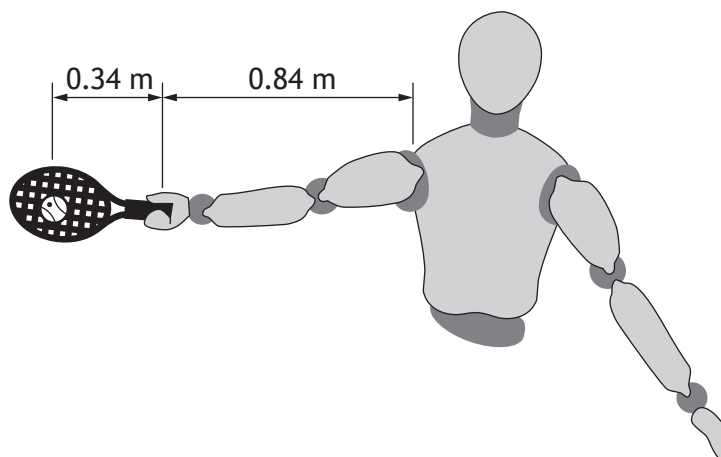

- (a) Calculate the force that this player strikes the ball with to produce a torque of 295 Nm.

2



3. (continued)

A force-extension graph for the rope is shown below.

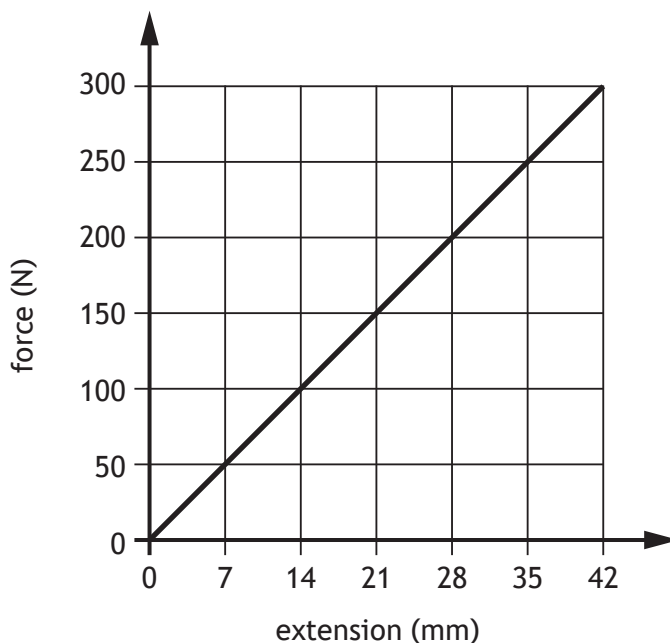

(b) Calculate the strain energy in the rope when it experiences a tensile force of 150 N.

2

[Turn over



4. Flexible couplings can be used rather than rigid couplings to connect two shafts. An example of a flexible coupling is shown.

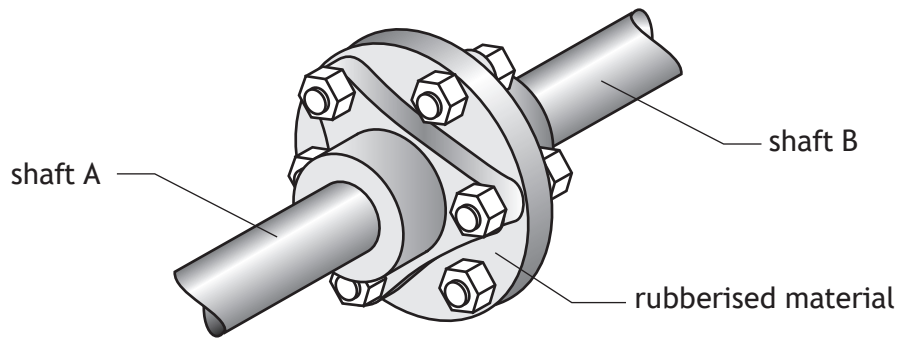

- (a) Describe two advantages of using flexible couplings rather than rigid couplings to connect shaft A and shaft B.

2

Advantage 1 \_\_\_\_\_  
\_\_\_\_\_  
\_\_\_\_\_

Advantage 2 \_\_\_\_\_  
\_\_\_\_\_  
\_\_\_\_\_

- (b) State the name of another mechanical method of joining two shafts together to transmit rotational motion.

1

\_\_\_\_\_



4. (continued)

A typical graphic symbol used by engineers to represent a bearing is shown below.

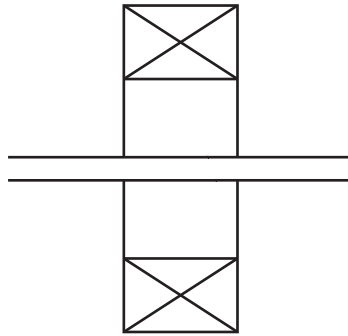

(c) Describe one function of a bearing in a drive system.

1

---

---

---

---

[Turn over



5. A variable temperature soldering iron is shown.



The soldering iron uses a two-state control system to turn the heating element on and off, and to monitor its output to maintain the desired temperature.

Complete the control diagram for the soldering iron below.

3

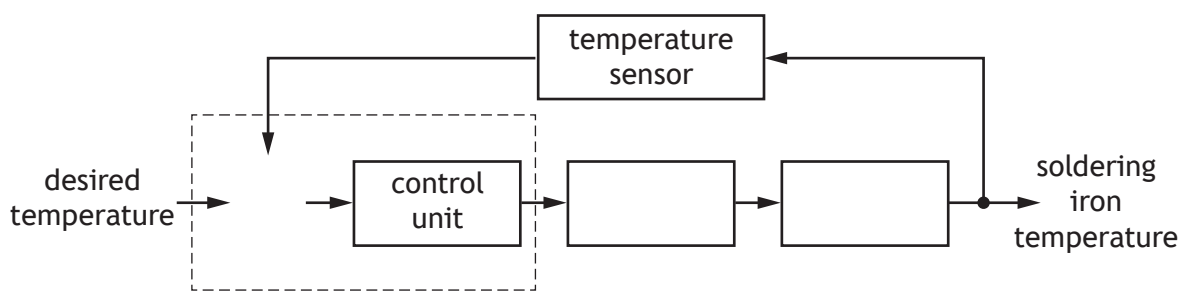

6. An engineer designs a control system for hair straighteners to maintain a steady temperature. A comparator or a difference amplifier could be used in this application.



Describe the operation of these amplifiers in controlling temperature. You must refer to **both** amplifiers in your answer.

3

Difference amplifier \_\_\_\_\_  
\_\_\_\_\_  
\_\_\_\_\_  
\_\_\_\_\_

Comparator \_\_\_\_\_  
\_\_\_\_\_  
\_\_\_\_\_  
\_\_\_\_\_

Difference amplifier or comparator \_\_\_\_\_  
\_\_\_\_\_  
\_\_\_\_\_  
\_\_\_\_\_

[Turn over



SECTION 2 — 90 marks

Attempt ALL questions

7. Viewing platforms are commonplace in sports academies to allow for filming of training and games.



A beam used in the construction of the viewing platform is shown.

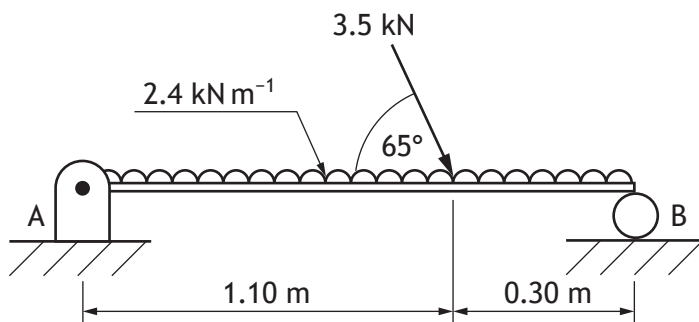

- (a) (i) Calculate the magnitude of the reaction at B.

3



7. (a) (continued)

(ii) Calculate the magnitude and direction of the reaction at A.

4



\* X 8 2 3 7 6 0 1 1 1 \*

7. (continued)

One sports academy is planning to install a new viewing platform.

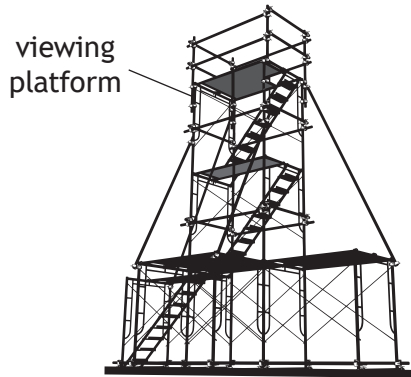

As part of the design phase, the academy's new structure is to be environmentally friendly.

- (b) (i) Describe two roles an environmental engineer would undertake in the design phase of the structure.

2

Role 1 \_\_\_\_\_

\_\_\_\_\_  
\_\_\_\_\_  
\_\_\_\_\_  
\_\_\_\_\_  
\_\_\_\_\_

Role 2 \_\_\_\_\_

\_\_\_\_\_  
\_\_\_\_\_  
\_\_\_\_\_  
\_\_\_\_\_  
\_\_\_\_\_



7. (b) (continued)

- (ii) Describe a positive and a negative economic impact for the academy due to the structure being environmentally friendly.

2

Positive economic impact \_\_\_\_\_

---

---

---

---

---

---

Negative economic impact \_\_\_\_\_

---

---

---

---

---

---

[Turn over



7. (continued)

A structural engineer is also involved in the design phase of the structure.

- (c) Describe two examples of how the structural engineer will apply calculations in the design phase of the structure.

2

Example 1 \_\_\_\_\_

\_\_\_\_\_

\_\_\_\_\_

\_\_\_\_\_

\_\_\_\_\_

\_\_\_\_\_

Example 2 \_\_\_\_\_

\_\_\_\_\_

\_\_\_\_\_

\_\_\_\_\_

\_\_\_\_\_

\_\_\_\_\_



[Turn over for next question

DO NOT WRITE ON THIS PAGE



\* X 8 2 3 7 6 0 1 1 5 \*

8. A lifting system to allow workers on a construction site to carry out essential maintenance is being developed.

MARKS DO NOT WRITE IN THIS MARGIN

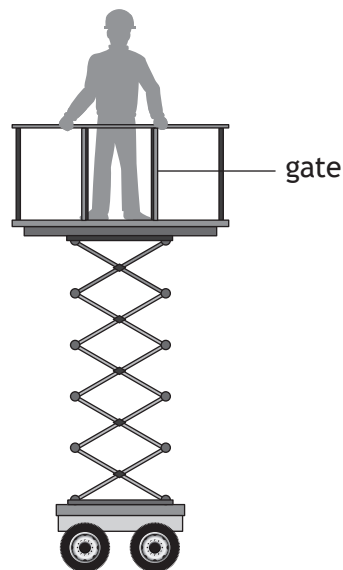

A warning system that will sound an alarm when the platform is in motion is needed. Two buttons are used to control the upward and downward motion of the platform.

Input/Output	Operation
alarm sounds	Z=1
gates open	A=0
maximum loading exceeded	B=1
button C pressed	C=1
button D pressed	D=1

A proposed design has the following specification (all conditions must be met).

The alarm (Z):

- will not sound unless the gate (A) is closed
- will not sound when the weight on the platform exceeds the maximum loading (B)
- will sound when either button (C) or (D) is pressed, but not when both are pressed at the same time.

- (a) Complete the Boolean equation for the alarm system in operation.

3

Z =



8. (continued)

Battery powered portable floodlights are to be installed on the construction site to allow work to be completed in lower light levels.



The battery is rated at 15 V, 13 A. In 4.0 hours, the useful output energy is 2.32 MJ.

- (b) Complete the energy audit diagram for the portable floodlight battery, showing the input and output energies, efficiency, and waste energy.

3

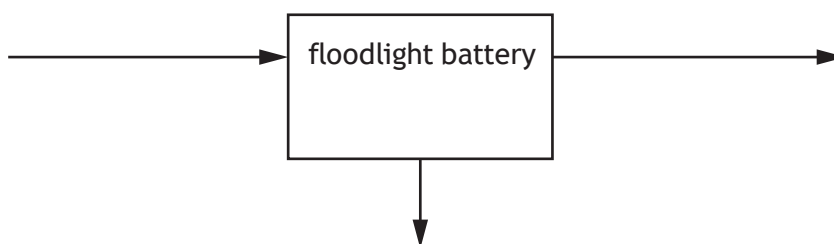

*Space for calculations*



8. (continued)

Due to the rapid expansion of the construction site, additional floodlights are to be installed.

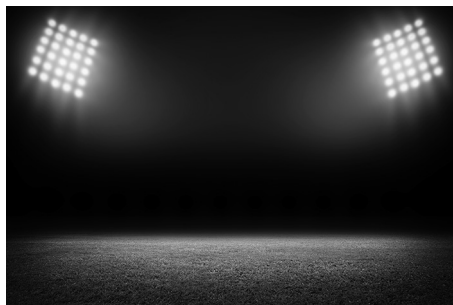

The diagram below shows part of the design for the frame that supports the floodlights.

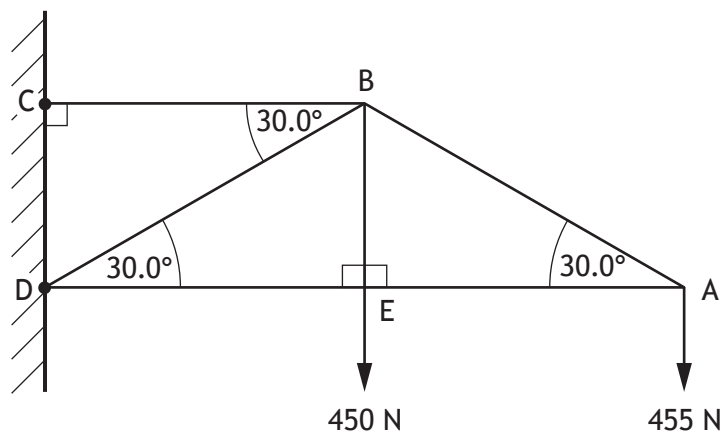

- (c) Calculate, using nodal analysis at nodes A and B, the magnitude and nature of the forces in members AB, AE, BD, and BC.

Member BE is a 450 N tie.

Complete the table below. Show all working and final units.

8

Member	Magnitude	Nature
AB		tie
AE		strut
BD		
BC		



8. (c) (continued)

*Space for calculations*

node A

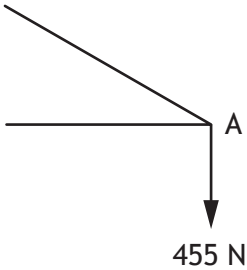

node B

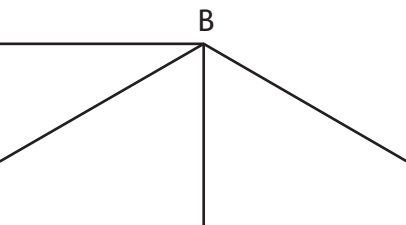

[BLANK PAGE]

DO NOT WRITE ON THIS PAGE



\* X 8 2 3 7 6 0 1 2 0 \*

9. An off-road, fully electric sports car will be used in a televised race. To ensure a good quality image is produced by the on-board video camera, a system is needed to keep the camera clean.



Editorial image; Rodrigo Garrido/shutterstock.com

The camera is placed on the outside of the car and a roll of clear plastic is placed over it.

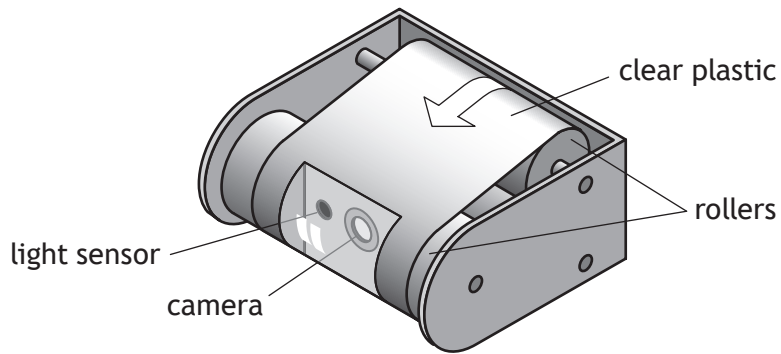

[Turn over



\* X 8 2 3 7 6 0 1 2 1 \*

9. (continued)

DO NOT  
WRITE IN  
THIS  
MARGIN

Light Dependent Resistor (LDR) graph for an ORP12 LDR

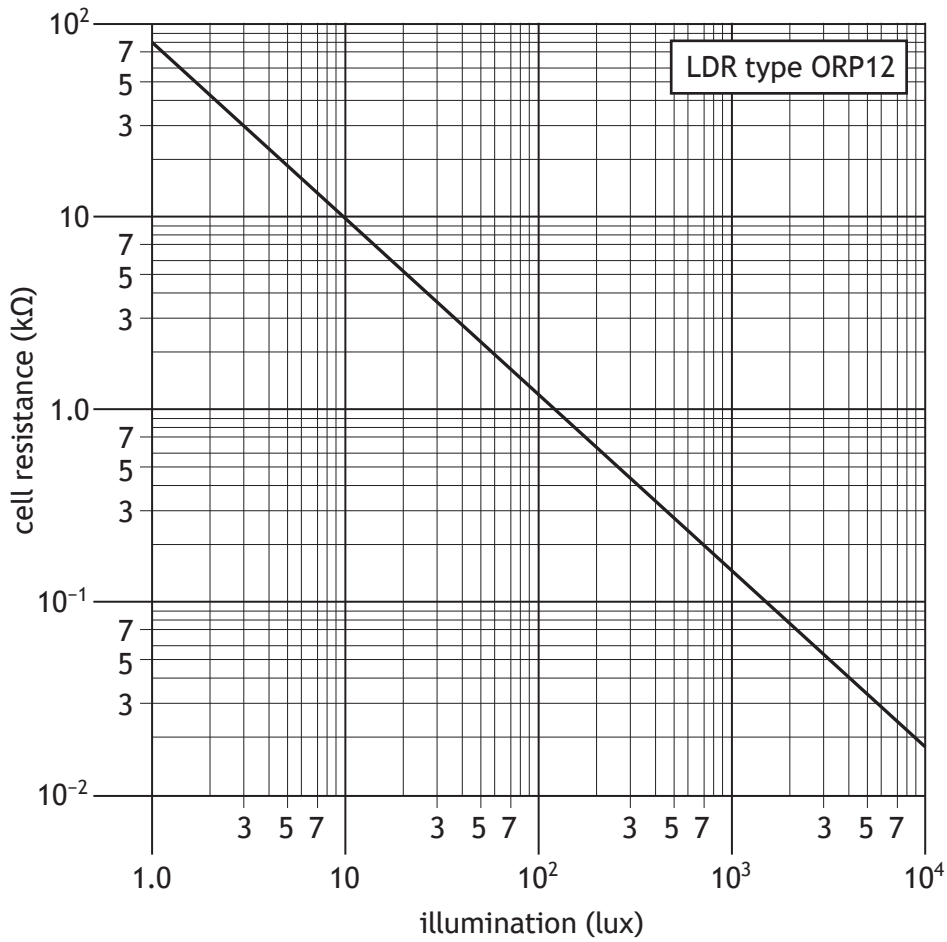

A light sensor is used to identify when the plastic is dirty. When it senses a value of less than 210 lux a motor spins to move clean plastic in front of the camera.

The control circuit is shown below.

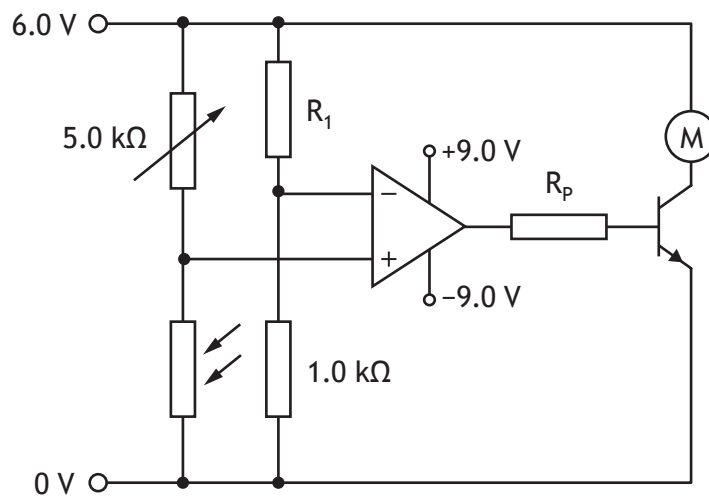

9. (continued)

(a) Calculate the value of  $R_1$  required to saturate the op-amp positive at 210 lux.

3

The motor requires 55 mA of current to operate.

The op-amp saturates to 78% of the supply voltage.  $V_{be}$  is 0.70 V when saturated. The transistor  $h_{fe}$  is 220.

(b) Calculate the required value of  $R_p$ .

4



9. (continued)

An alternative motor with a MOSFET driver is also considered. The MOSFET has a resistance of  $2.3 \Omega$  when fully saturated and the motor is rated as  $0.40 \text{ W}$  at  $6.0 \text{ V}$ .

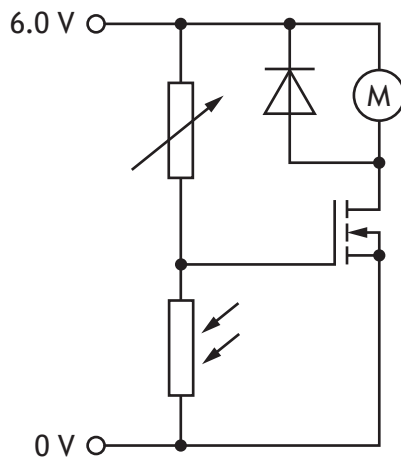

(c) Calculate the drain-source current when the MOSFET is fully saturated.

3



9. (continued)

As part of the car's control system, the windows are to be opened and closed automatically. The following control circuit is produced by an electronic engineer.

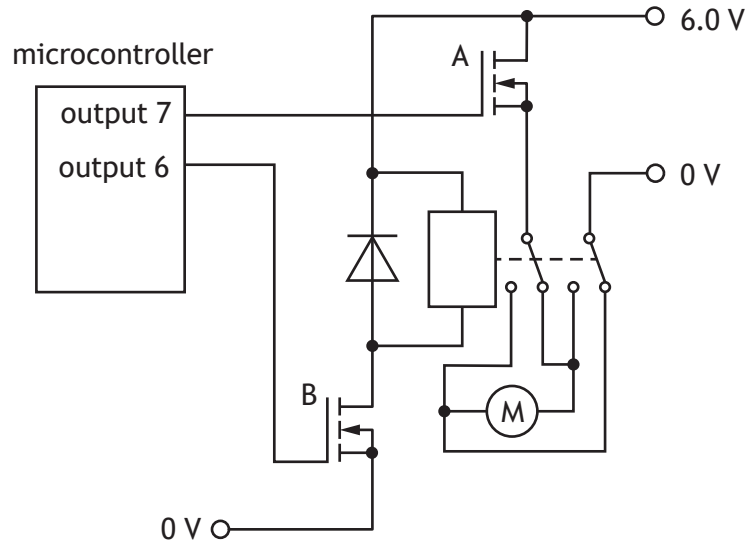

- (d) Explain, with reference to the circuit above, the impact that switching output 7 high then output 6 high has on the motor.

2

---



---



---



---



---



---



---

[Turn over



9. (continued)

An amplifier is required to boost the signal from the camera so that it can be transmitted. The graph below shows the desired output voltage for the given input.

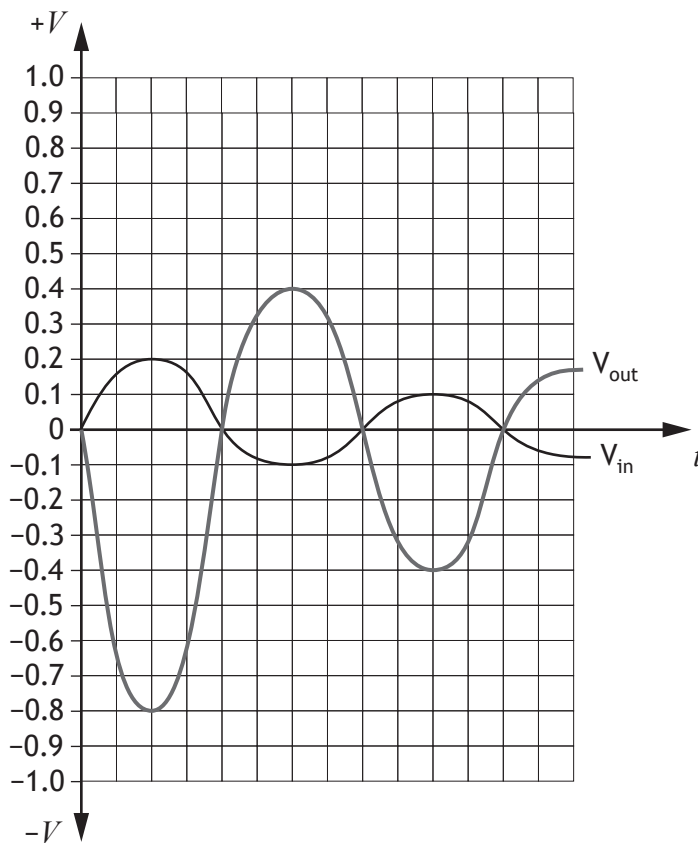

(e) State an op-amp configuration that will produce the desired output.

1

---

(f) Calculate the required gain of the op-amp.

1



9. (continued)

When testing the circuit, the output produced the following trace.

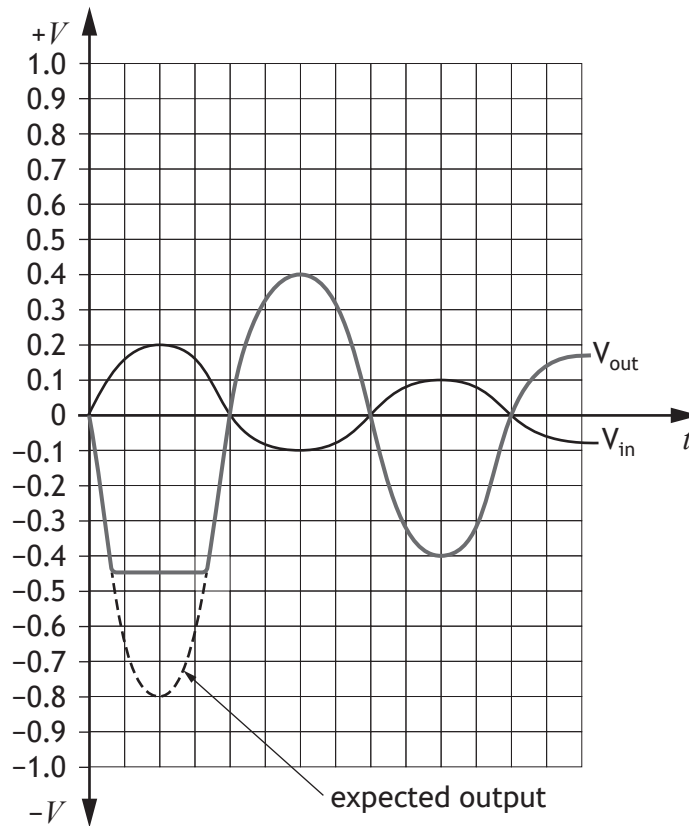

(g) State why the op-amp circuit produces the output shown.

1

---



---

[Turn over



10. A mechanical engineer must design a pneumatic circuit to meet the following criteria:

- when push buttons on  $V_A$  and  $V_B$  are **not** pressed, or when the lever on  $V_C$  is thrown to the on state, a double-acting cylinder must outstroke ( $\text{Outstroke} = \bar{A}.\bar{B} + C$ )
- a short time after the cylinder outstrokes, it must instroke automatically
- the cylinder must instroke slowly.

An initial design for the circuit, shown below, is known to have faults.

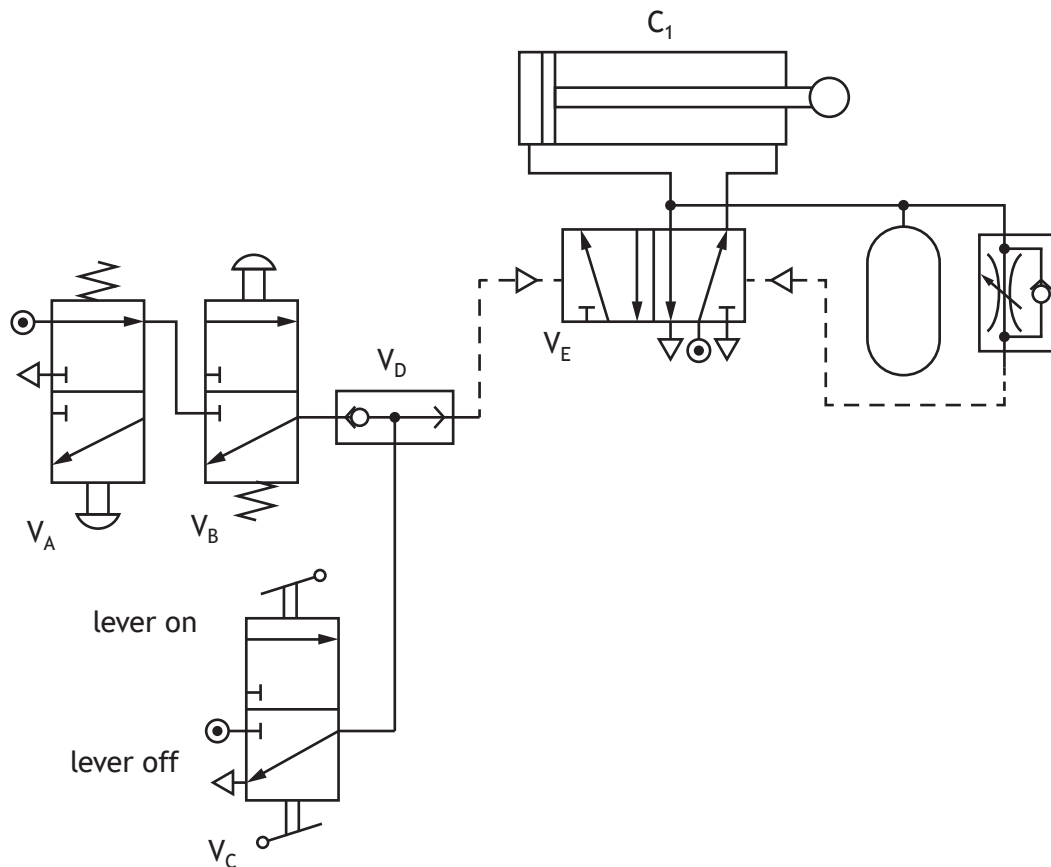

\* X 8 2 3 7 6 0 1 2 8 \*

10. (continued)

(a) Describe four faults with the circuit design shown opposite.

4

Fault 1 \_\_\_\_\_

\_\_\_\_\_

\_\_\_\_\_

Fault 2 \_\_\_\_\_

\_\_\_\_\_

\_\_\_\_\_

Fault 3 \_\_\_\_\_

\_\_\_\_\_

\_\_\_\_\_

Fault 4 \_\_\_\_\_

\_\_\_\_\_

\_\_\_\_\_

[Turn over



\* X 8 2 3 7 6 0 1 2 9 \*

## 10. (continued)

To reduce costs and allow greater flexibility, an electronic engineer is asked to produce an alternative solution using a microcontroller.

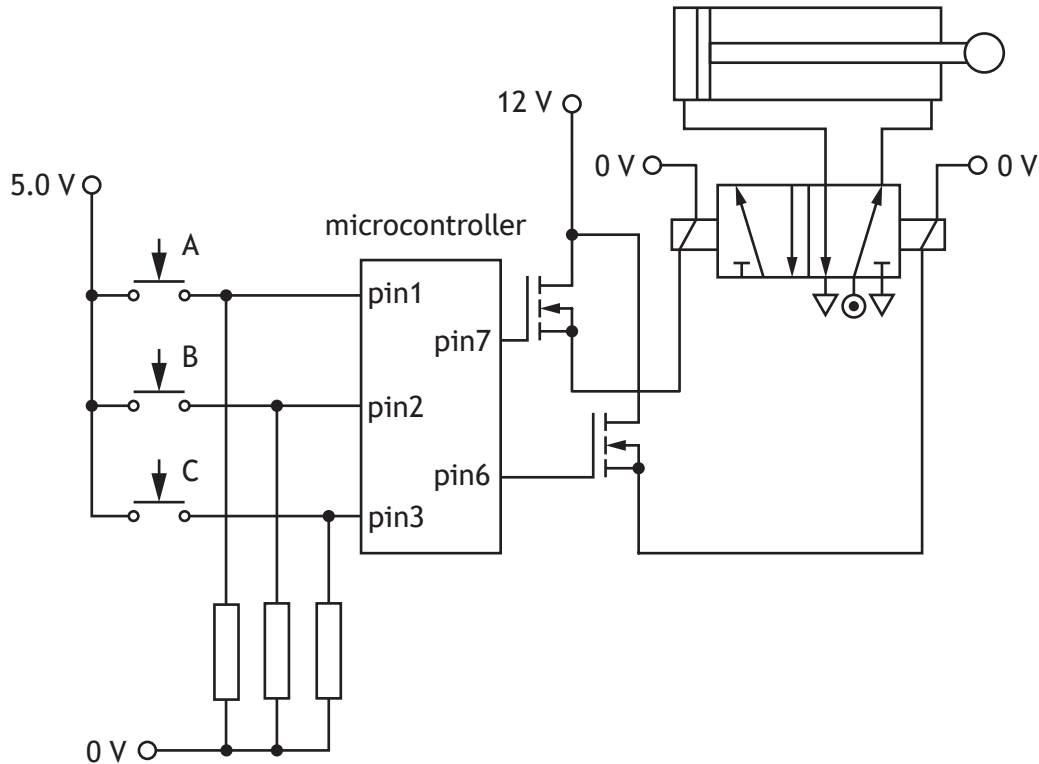

The program to control the cylinder must meet the following criteria:

- $\text{outstroke} = \bar{A} \cdot \bar{B} + C$
- the cylinder must remain outstroked for 1500 milliseconds before instroking
- 200 milliseconds after the command to instroke, the system must start monitoring the switches again.



\* X 8 2 3 7 6 0 1 3 0 \*

10. (continued)

The program shown below in PBASIC and ARDUINO code is known to have faults.

<pre> main: if pin3 = 1 then jump       if pin2 = 1 then main       if pin1 = 0 then main  jump: high 7       pause 1500       high 6       pause 200       low 6        goto jump         </pre>	<pre> void loop(){   if (digitalRead(3)==HIGH){jump();}   else if (digitalRead(2)==HIGH){loop();}   else if (digitalRead(1)==LOW){loop();}   else{loop();} }  void jump(){   digitalWrite(7,HIGH);   delay(1500);    digitalWrite(6,HIGH);   delay(200);   digitalWrite(6,LOW); }         </pre>
---	--

(b) Describe three different faults in the program shown above.

3

Fault 1 \_\_\_\_\_

\_\_\_\_\_

\_\_\_\_\_

Fault 2 \_\_\_\_\_

\_\_\_\_\_

\_\_\_\_\_

Fault 3 \_\_\_\_\_

\_\_\_\_\_

\_\_\_\_\_



10. (continued)

MARKS DO NOT WRITE IN THIS MARGIN

A further part of the system controls the motion of two cylinders.

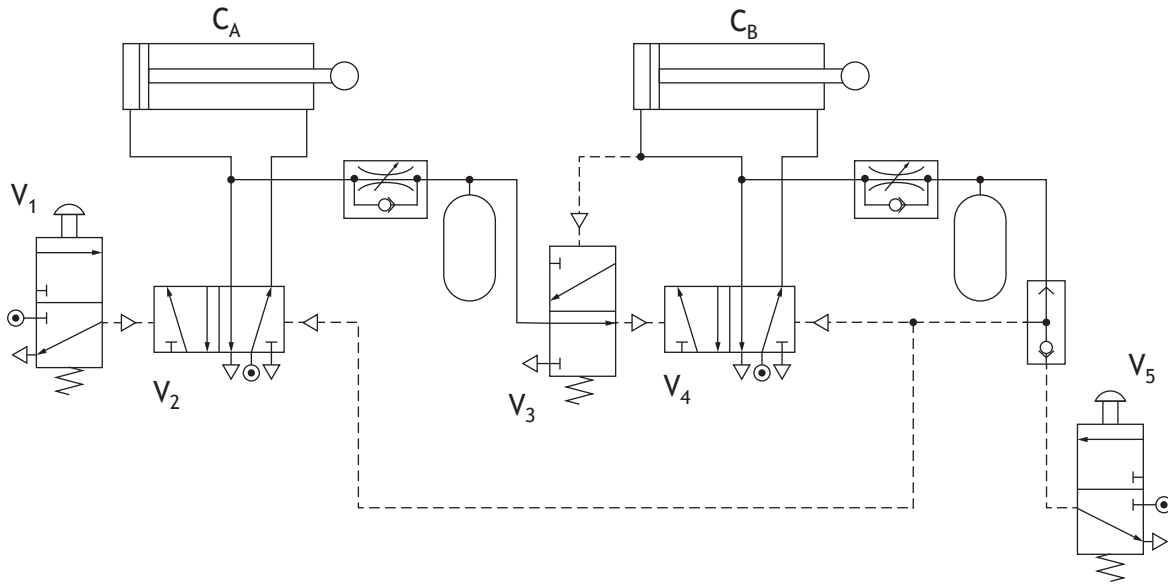

(c) Describe, with reference to the components, the full operation of the pneumatic circuit when the button on  $V_1$  is pressed.

5

---

---

---

---

---

---

---

---

---

---

---

---

---

---

---

---

---

---

---

---

---

---

---

---



[Turn over for next question

DO NOT WRITE ON THIS PAGE



\* X 8 2 3 7 6 0 1 3 3 \*

11. A tow truck is designed to include additional structural and safety features. The tow truck uses outriggers to ensure stability when heavier vehicles are lifted.

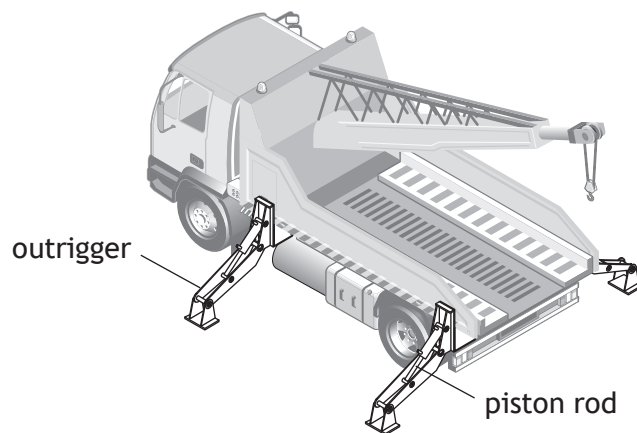

The piston in each outrigger produces a force of 49 kN. The piston rods are to be manufactured from mild steel with a factor of safety of 15. The piston rod has a circular cross section.

- (a) (i) Calculate the required diameter of the piston rod.

4



11. (a) (continued)

Each piston rod is 320 mm long.

- (ii) Calculate the change in length of a piston rod when it experiences a stress value of  $86 \text{ N mm}^{-2}$ .

3

Vehicles are lifted by a mechanical drive system.

- (b) Describe two different skills required by a mechanical engineer during the design phase of a drive system.

2

Skill 1 \_\_\_\_\_

---

---

---

---

Skill 2 \_\_\_\_\_

---

---

---

---



11. (continued)

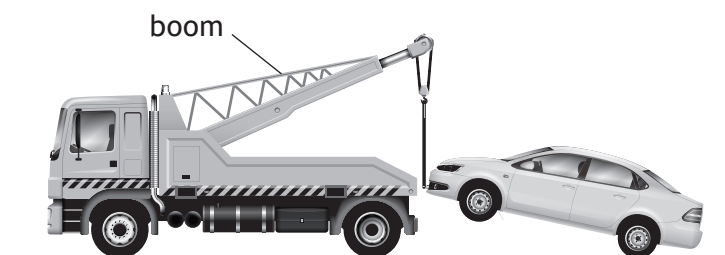

The structural design for the frame used to support the boom is shown.

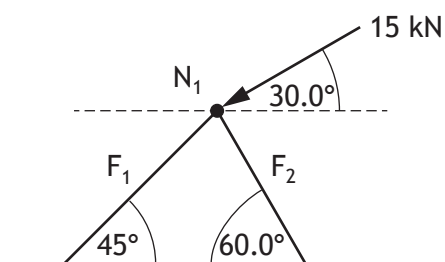

Node  $N_1$  is in static equilibrium.

$F_1$  is a strut, and  $F_2$  is a tie.

- (c) (i) Write, in its simplest form, the **equation** for the vertical forces acting on  $N_1$  (include all forces and their angles).

1

- (ii) Write, in its simplest form, the **equation** for the horizontal forces acting on  $N_1$  (include all forces and their angles).

1



11. (c) (continued)

(iii) Calculate the magnitude of the forces in members  $F_1$  and  $F_2$ .

3



11. (continued)

An initial design for a control system to operate the tow truck's lighting is shown.

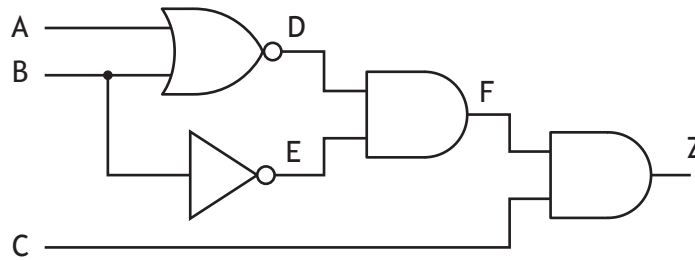

(d) Complete the truth table for the logic diagram.

Include the intermediate logic values for D, E and F.

4

A	B	C	D	E	F	Z
0	0	0				
0	0	1				
0	1	0				
0	1	1				
1	0	0				
1	0	1				
1	1	0				
1	1	1				



[Turn over for next question

DO NOT WRITE ON THIS PAGE



\* X 8 2 3 7 6 0 1 3 9 \*

12. A science laboratory is investigating the use of an electronic control system to weigh chemical materials. The materials are released into a container from a hopper and are weighed using a scale comprised of three strain gauges.

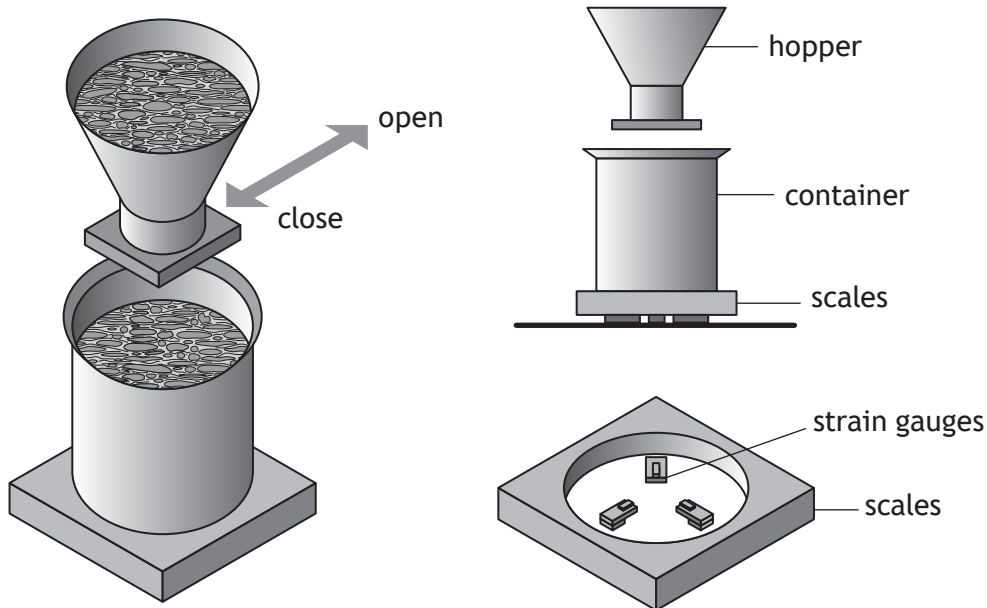

A prototype circuit using a difference amplifier is produced to test one of the strain gauges as it weighs the materials.

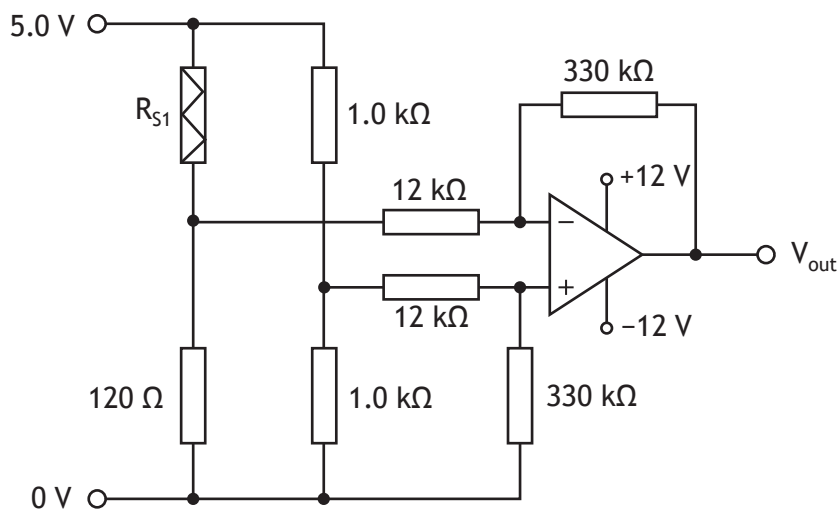

\* X 8 2 3 7 6 0 1 4 0 \*

12. (continued)

During an initial test  $R_{s1}$  was found to be  $121.5 \Omega$ .

(a) Calculate  $V_{out}$ .

3

[Turn over



12. (continued)

A difference amplifier circuit like the one shown in part (a) on page 40 is used for each of the three strain gauges.

A further circuit is designed to combine their outputs. It must produce an output of 2.3 V when the correct amount of materials are added to the container.

When the materials are added, the input and output voltages produced are shown below.

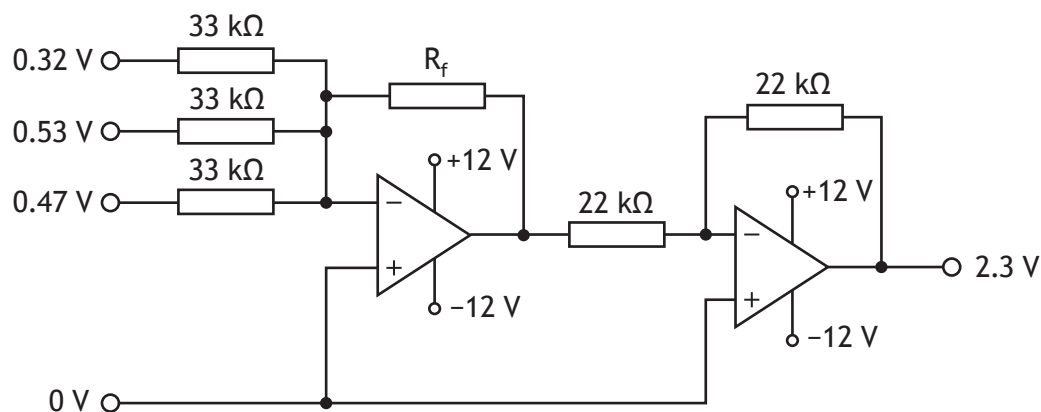

(b) Calculate a suitable value for  $R_f$ .

2



[Turn over for next question

DO NOT WRITE ON THIS PAGE



\* X 8 2 3 7 6 0 1 4 3 \*

## 12. (continued)

The output voltage is fed into a logic circuit to indicate whether an appropriate weight of materials is in the container.

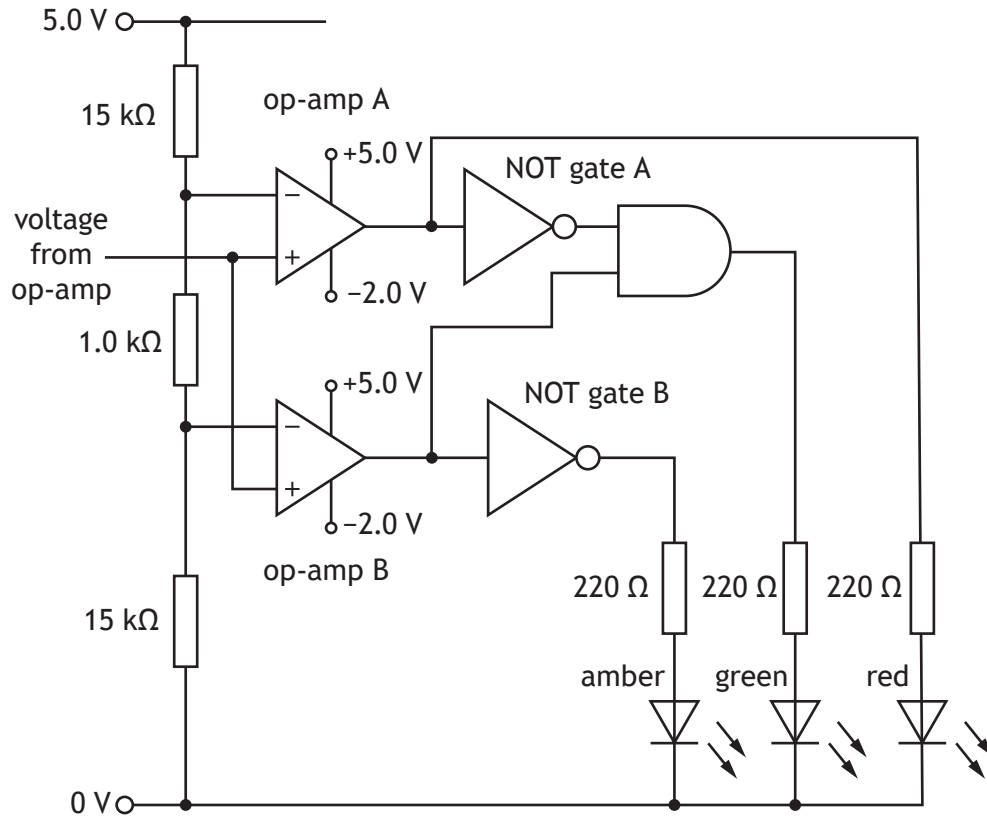

An amber LED lights if there is not enough material. A green LED lights if there is the correct amount of material. A red LED lights if there is too much material. When the op-amps saturate negatively they will output 0 V.



\* X 8 2 3 7 6 0 1 4 4 \*



## 12. (continued)

A second prototype using a microcontroller instead of a logic circuit is to be tested. The system must meet the following criteria:

- the system must wait until a safety switch has been activated
- when either of the manual start switches A or B are pressed a signal must be sent to open the hopper and the amber LED must come on
- if the weight reading is between a value of 100 and 120 the green LED alone must come on and the hopper must close
- if the reading is greater than 120 the hopper must close and the red LED must flash 5 times per second until the reading drops to less than 120 (material will be removed manually by an operator to reduce the weight).

Input	Pin	Output
	7	hopper open (1)/close (0)
	6	red LED
	5	green LED
	4	amber LED
safety switch	3	
manual start switch A	2	
manual start switch B	1	
weight (analogue value)	0	



12. (continued)

MARKS DO NOT WRITE IN THIS MARGIN

(d) Complete, with reference to the pinout table and the criteria given opposite, a flowchart for the system.

10

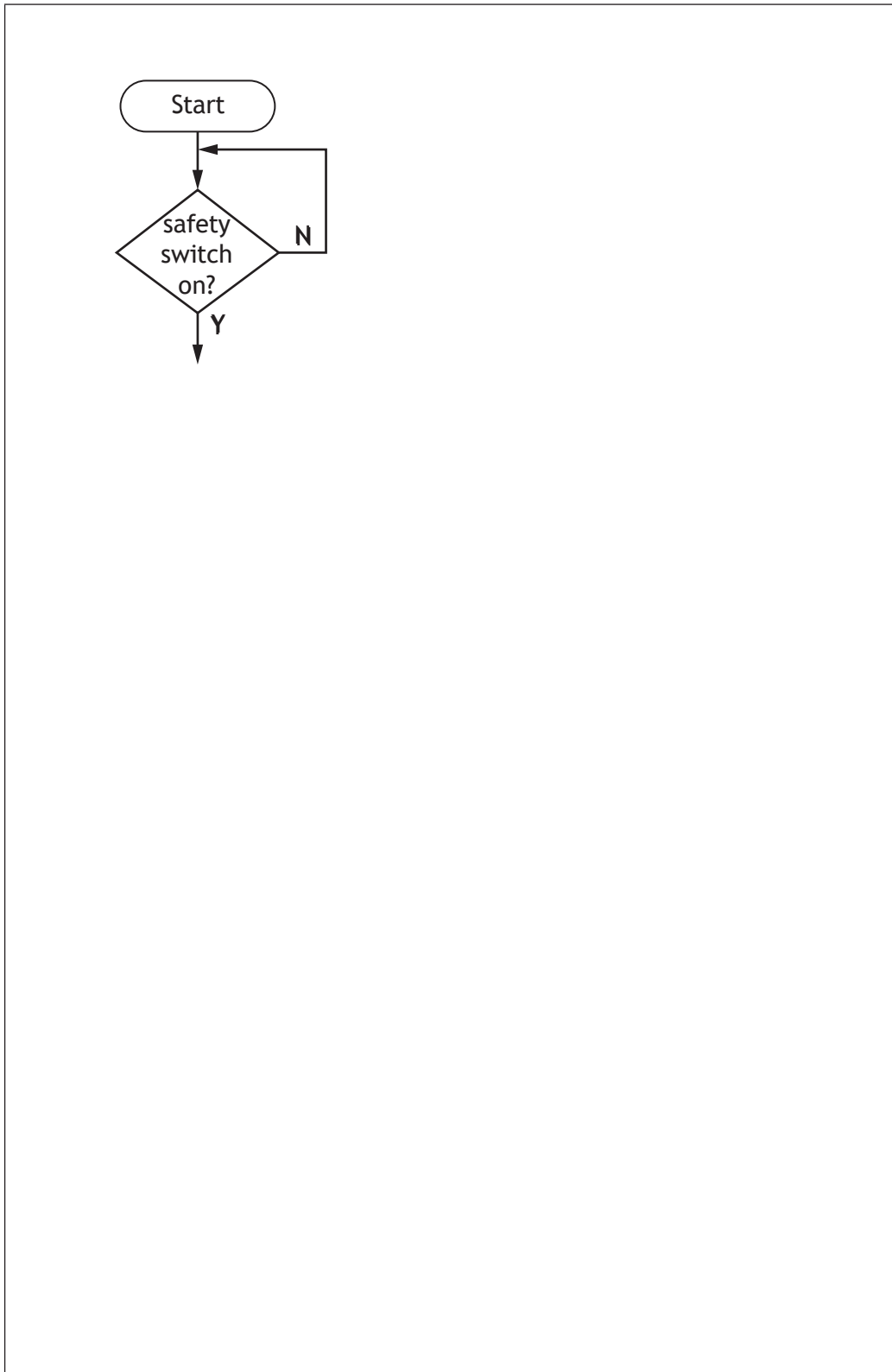

[END OF QUESTION PAPER]



MARKS DO NOT  
WRITE IN  
THIS  
MARGIN

ADDITIONAL SPACE FOR ANSWERS



\* X 8 2 3 7 6 0 1 4 8 \*

MARKS DO NOT  
WRITE IN  
THIS  
MARGIN

ADDITIONAL SPACE FOR ANSWERS



\* X 8 2 3 7 6 0 1 4 9 \*

[BLANK PAGE]

DO NOT WRITE ON THIS PAGE



\* X 8 2 3 7 6 0 1 5 0 \*

[BLANK PAGE]

DO NOT WRITE ON THIS PAGE



\* X 8 2 3 7 6 0 1 5 1 \*

[BLANK PAGE]

DO NOT WRITE ON THIS PAGE

*Acknowledgement of copyright*

- Question 5      Matee Nuserm/shutterstock.com  
Question 6      Plus69/shutterstock.com  
Question 7 (a)    Ninja Artist/shutterstock.com  
Question 8 (b)    Image by Tyler Hendy is taken from pexels.com  
Question 8 (c)    winui/shutterstock.com  
Question 9      Editorial image: Rodrigo Garrido/shutterstock.com  
Question 11      aurielaki/shutterstock.com  
Question 11 (c)    Yuri Schmidt/shutterstock.com



\* X 8 2 3 7 6 0 1 5 2 \*