

FOR OFFICIAL USE



--	--	--	--	--	--

National  
Qualifications  
2024

Mark

--

**X823/76/01**

**Engineering Science**

FRIDAY, 17 MAY

9:00 AM – 11:30 AM



\* X 8 2 3 7 6 0 1 \*

Fill in these boxes and read what is printed below.

Full name of centre

--

Town

--

Forename(s)

--

Surname

--

Number of seat

--

Date of birth

Day

--	--

Month

--	--

Year

--	--

Scottish candidate number

--	--	--	--	--	--	--	--	--	--

**Total marks — 110**

**SECTION 1 — 20 marks**

Attempt ALL questions.

**SECTION 2 — 90 marks**

Attempt ALL questions.

**Show all working and units where appropriate.**

You should refer to the Higher Engineering Science Data Booklet which you have been given. The number of significant figures expressed in a final answer should be equivalent to the least significant data value given in the question. Answers that have two more figures or one less figure than this will be accepted.

Write your answers clearly in the spaces provided in this booklet. Additional space for answers is provided at the end of this booklet. If you use this space you must clearly identify the question number you are attempting.

Use **blue** or **black** ink.

Before leaving the examination room you must give this booklet to the Invigilator; if you do not, you may lose all the marks for this paper.



\* X 8 2 3 7 6 0 1 0 1 \*

SECTION 1 — 20 marks

Attempt ALL questions

1. A control circuit is required for a home security system.

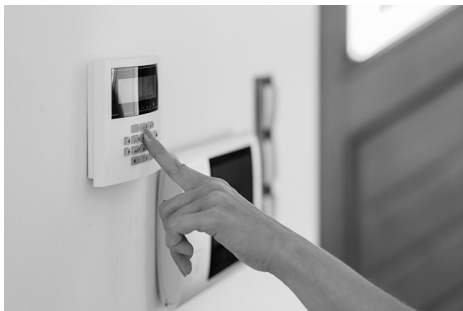

As part of the design for the home security system, an electronic engineer needs a digital logic circuit to satisfy the Boolean equation, shown below.

$$Z = (\overline{A \cdot B}) \cdot (C + D)$$

Draw a digital logic circuit for this Boolean equation.

3

A ○

B ○

C ○

D ○

○ Z



2. A coastguard rescue helicopter is used to lift a stranded casualty from the sea.



A motorised lifting mechanism has a drum diameter of 0.84 m.

The mechanism lifts a coastguard, the casualty and a stretcher of mass 76 kg, 95 kg and 18 kg respectively.

Calculate the torque acting on the drum.

2



3. A beam is being tested.

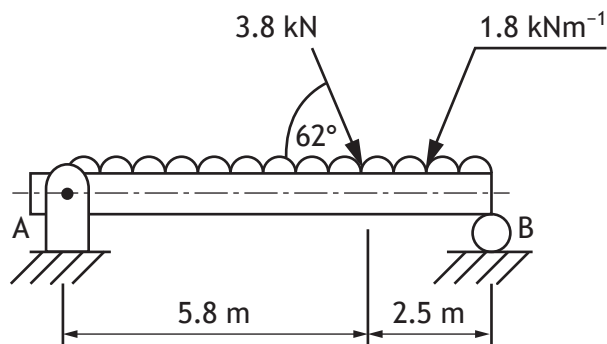

The beam is subjected to loading as shown above.

Calculate, by taking moments about A, the vertical reaction at B.

4



4. A range of electronic circuits are used to control a night-time water fountain show. The water fountain show is made from a number of individual water jets.



The following circuit is part of the system used to operate one of the water jets.

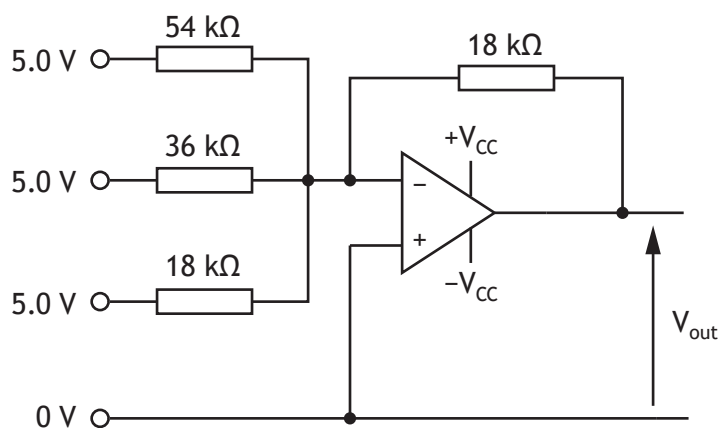

Calculate the output voltage ( $V_{out}$ ) from the operational amplifier (op-amp) shown above.

2



5. A ductile specimen was subjected to a tensile test. The results are shown in the graph below.

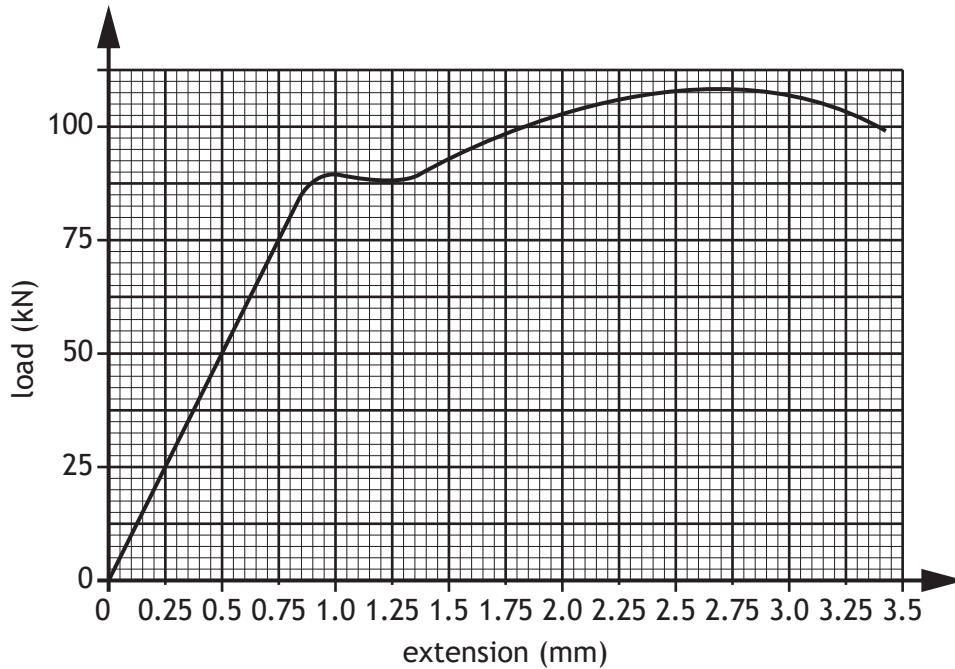

- (a) Identify the ultimate tensile force acting on the specimen by annotating the graph above. 1
- (b) Calculate the strain energy stored in the specimen when the load is 75 kN. 2



5. (continued)

- (c) Describe the effect on the specimen shown opposite, when a force of 50 kN is applied and then removed.

1

---

---

---

---

- (d) Sketch, on the same axes on the graph opposite, a load-extension graph of a more brittle material than the original specimen tested.

1

[Turn over



6. An electronic engineer has written code to control a microcontroller-operated motor for a running machine.



The code is written to meet the following specification:

- If the start switch is on and the runner is sensed, the motor switches on.
- The motor operates using pulse-width modulation (PWM) with a mark to space ratio of 1:3.
- The sequence repeats.

The pin connection table is shown below.

Input connection	Pin	Output connection
	7	motor
runner sensor (high when sensed)	1	
start switch	0	

Part of the same program is shown below in PBASIC and ARDUINO code.

#### PBASIC

```
main: if pin 0 = 0 then main
      if pin 1 = 1 then main

pwm: high 7
     pause 15
     low 7
     pause 15
     goto main
```

#### ARDUINO

```
void loop() {
  if (digitalRead(pin0)==LOW){
    loop();}
  if (digitalRead(pin1)==HIGH){
    loop();}
}

void pwm(){
  digitalWrite(pin7,HIGH);
  delay(15);
  digitalWrite(pin7,LOW);
  delay(15);
  return;
}
```



\* X 8 2 3 7 6 0 1 0 8 \*

6. (continued)

Two faults in the code opposite are shown in **bold**.

- (a) Correct the two different faults in the program opposite by writing the corrected code.

You may show corrections for either PBASIC or ARDUINO.

2

Correction 1 \_\_\_\_\_  
 \_\_\_\_\_

Correction 2 \_\_\_\_\_  
 \_\_\_\_\_

- (b) Complete the graph below to show a PWM signal with a mark to space ratio of 1:3.

You must show at least three pulses.

2

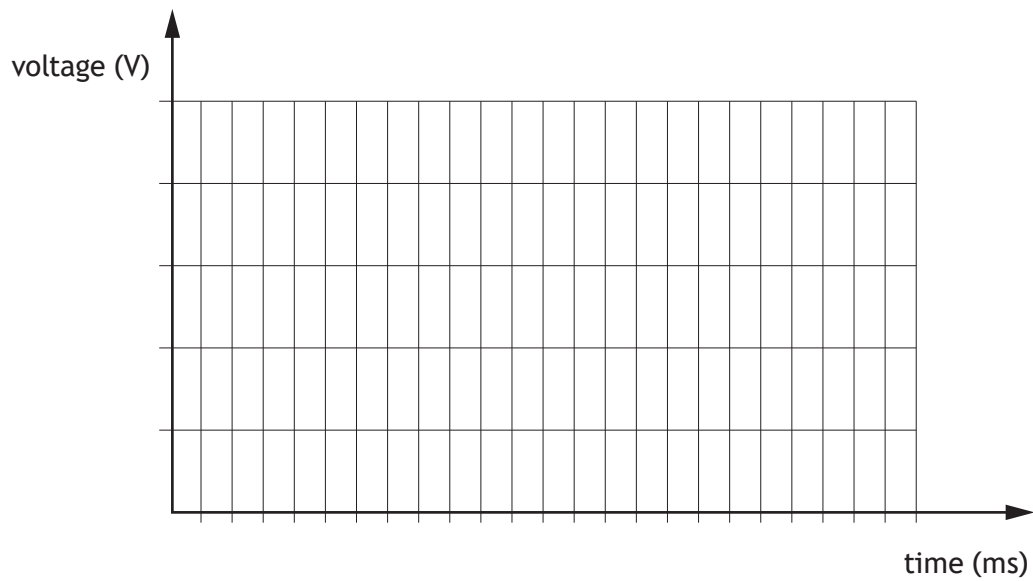

[Turn over



## SECTION 2 — 90 marks

Attempt ALL questions

7. A packaging process in a factory is to be automated.

When a package reaches the end of a conveyor it is to be held in place while two staples are attached to seal the package closed. It is then released to the next stage of the process.

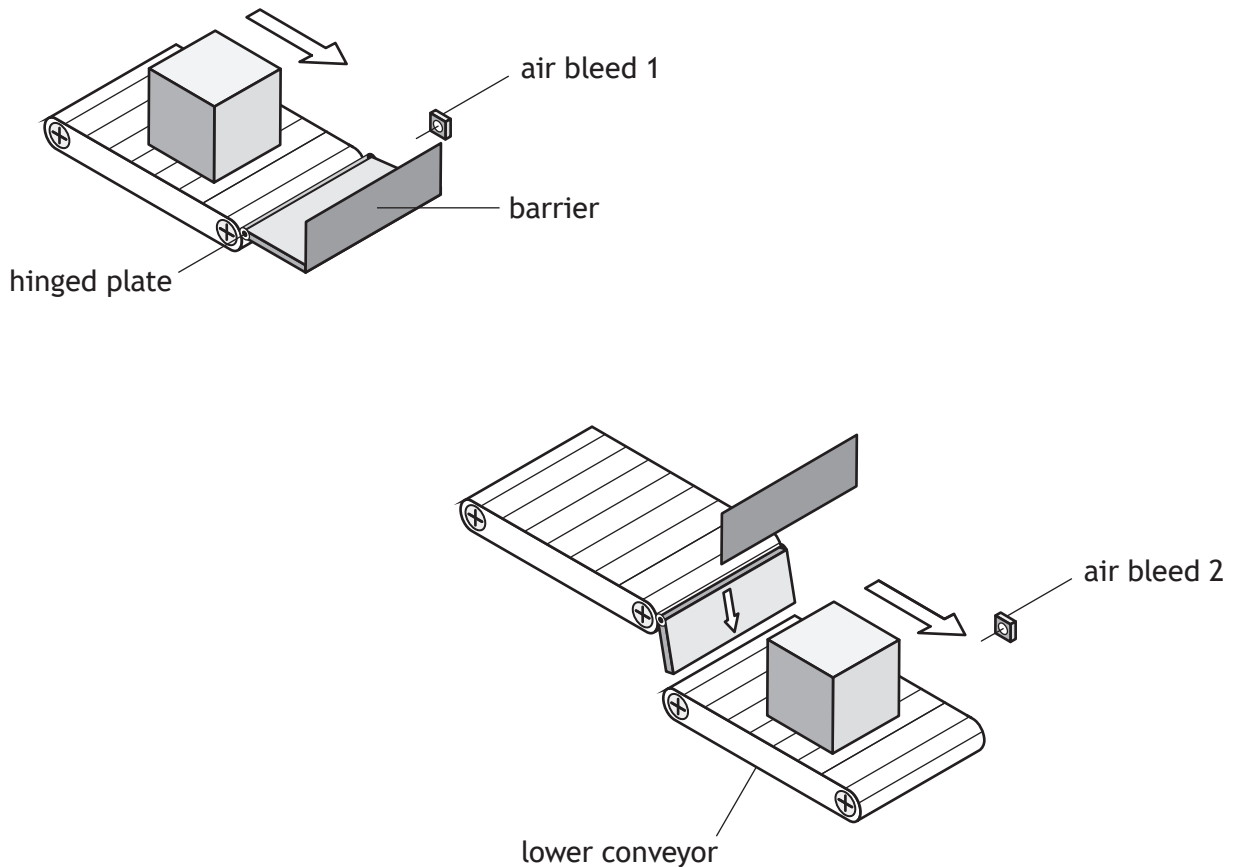

The full operation of the pneumatic circuit is described below:

- When the package is sensed by an air bleed operated diaphragm (air bleed 1), cylinder A outstrokes to hold the package in place.
- After a controlled delay, cylinders B and C outstroke to close the package lid and staple it in place.
- After a further controlled delay, cylinders A, B, C and D instroke and the package is allowed to drop down to the lower conveyor.
- When the package is sensed by air bleed 2, cylinder D outstrokes to close the chute.



\* X 8 2 3 7 6 0 1 1 0 \*

[Turn over for next question

DO NOT WRITE ON THIS PAGE



\* X 8 2 3 7 6 0 1 1 1 \*

7. (continued)

A proposed design for the pneumatic control system is shown below.

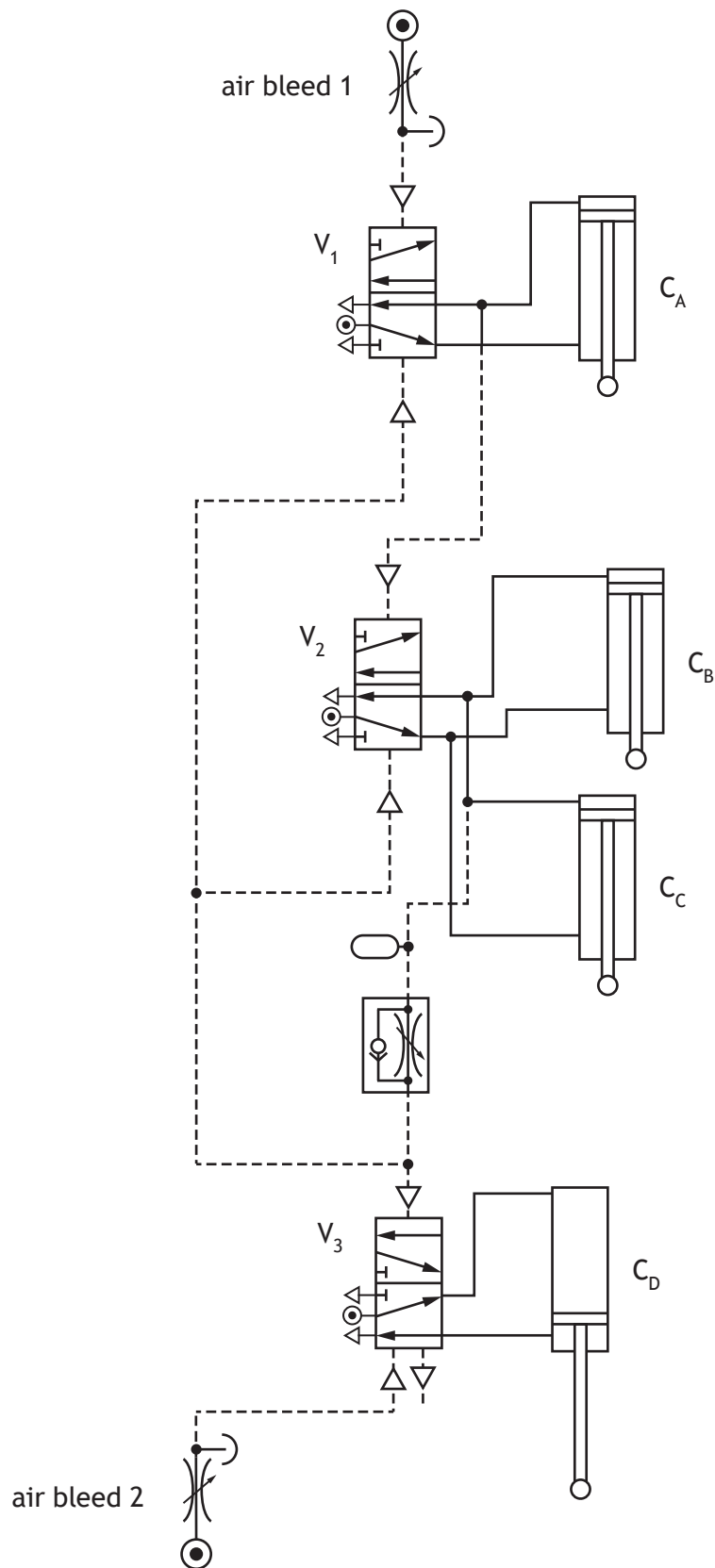

7. (continued)

- (a) Identify three faults with the design shown opposite, and describe how each one should be corrected.

Fault 1 \_\_\_\_\_  
\_\_\_\_\_  
\_\_\_\_\_  
\_\_\_\_\_  
\_\_\_\_\_

Fault 2 \_\_\_\_\_  
\_\_\_\_\_  
\_\_\_\_\_  
\_\_\_\_\_  
\_\_\_\_\_

Fault 3 \_\_\_\_\_  
\_\_\_\_\_  
\_\_\_\_\_  
\_\_\_\_\_  
\_\_\_\_\_

[Turn over



7. (continued)

An engineer considered using electronically-controlled mechanical systems to operate this process instead of pneumatics.

- (b) (i) Describe two **environmental** reasons why pneumatics was the preferred option.

2

Reason 1 \_\_\_\_\_

\_\_\_\_\_

\_\_\_\_\_

\_\_\_\_\_

\_\_\_\_\_

Reason 2 \_\_\_\_\_

\_\_\_\_\_

\_\_\_\_\_

\_\_\_\_\_

\_\_\_\_\_

- (ii) Describe how a mechanical engineer applies mathematical skills when designing a pneumatic system.

1

\_\_\_\_\_

\_\_\_\_\_

\_\_\_\_\_

\_\_\_\_\_



\* X 8 2 3 7 6 0 1 1 4 \*

7. (continued)

MARKS DO NOT WRITE IN THIS MARGIN

A further part of the control system requires valves to be actuated by electronic signals when a sensor is exposed to light. The control circuit for a solenoid actuator is shown below.

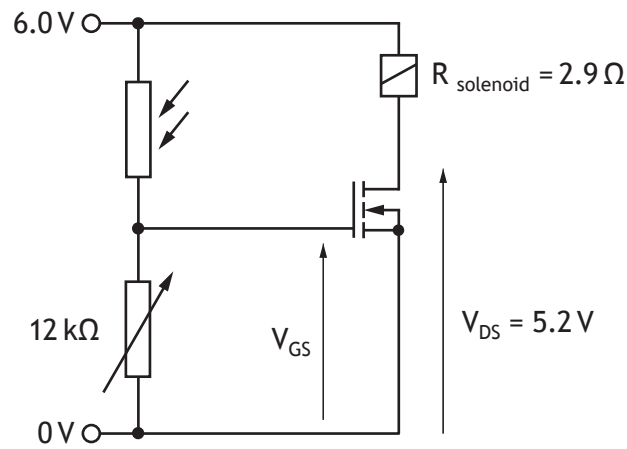

The characteristics of the circuit are shown in the table below.

Gate voltage ( $V_{GS}$ )	Current ( $I_{DS}$ )
5.5 V	430 mA
5.0 V	415 mA
4.5 V	362 mA
4.2 V	276 mA
4.0 V	88.3 mA
3.8 V	12.4 mA

- (c) Determine, using this table, the gate voltage ( $V_{GS}$ ) for the conditions in the circuit above.

3



## 7. (continued)

The factory also produces frosted glass sheets, and they must be tested before they are packaged.

A system is needed to check that a certain amount of light can pass through these sheets and record how many are suitable for packaging.

A preliminary design must meet the following specification:

- A position sensor detects when a sheet is in position for testing.
- When a sheet is in position, a light source switches on and a reading is taken from an analogue light sensor.
- If the reading from the sensor is between 50 and 100, a pneumatic cylinder outstrokes for one second to push the sheet into a packing area.
- If the reading is less than 50 or more than 100, the sheet is removed by an operator for disposal.
- When the sheet is no longer detected in position the process restarts.
- When 10 sheets meet the requirements, the light source switches off and the system stops.

The table below identifies the connections to the microcontroller.

Input	Pin	Output
	7	pneumatic cylinder control
	6	light source
position sensor	1	
light sensor (analogue)	0	

- (d) Complete, with reference to the specification and the input/output table, the flowchart shown opposite for the control of the system.

5



\* X 8 2 3 7 6 0 1 1 6 \*

7. (d) (continued)

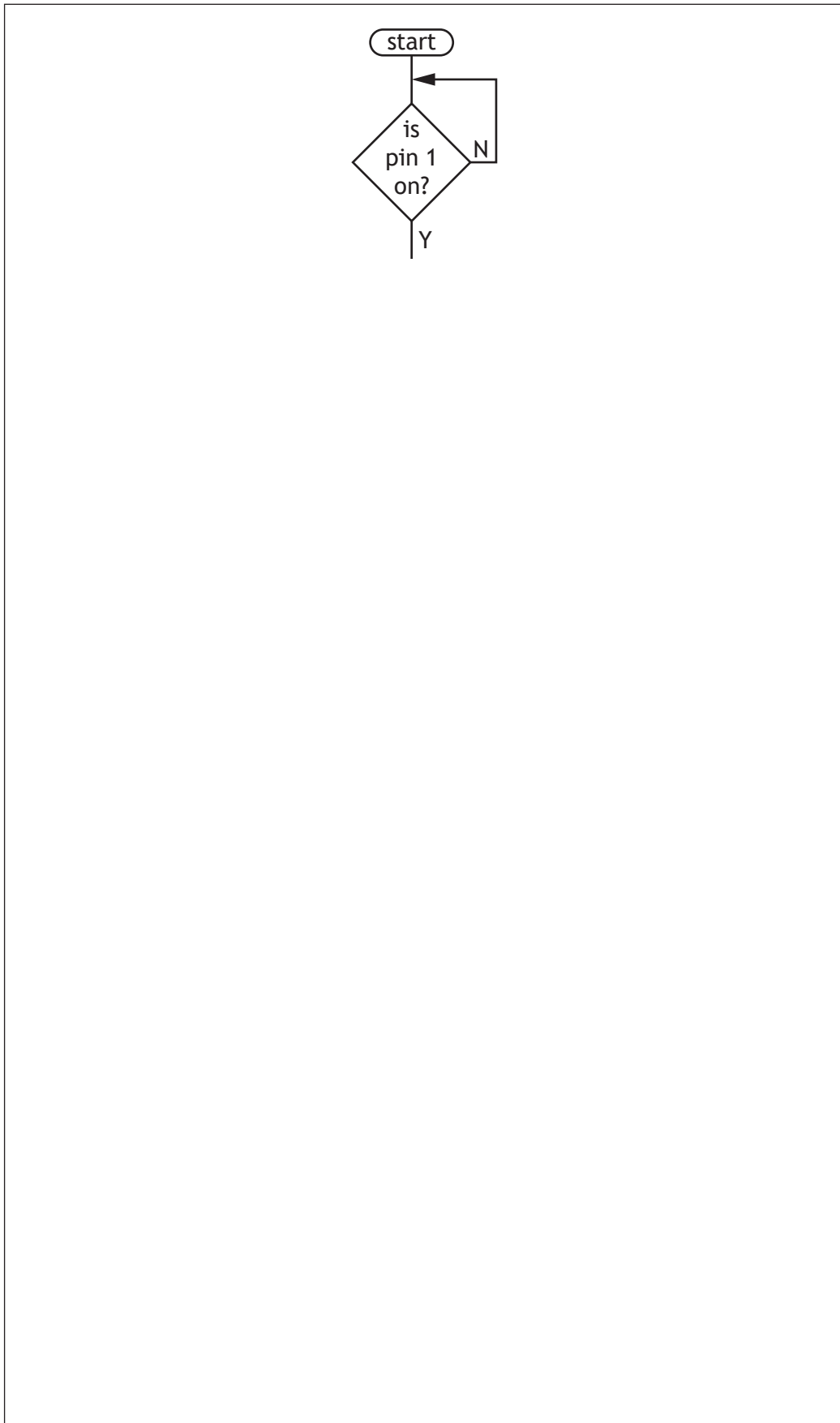

8. A recycling plant is developing a system to separate different types of waste so that they can be packed and sold to manufacturers.



One stage of the process uses weight sensors to detect plastic waste. Jets of air from a fan are then used to separate the plastic waste from heavier items such as metal waste.

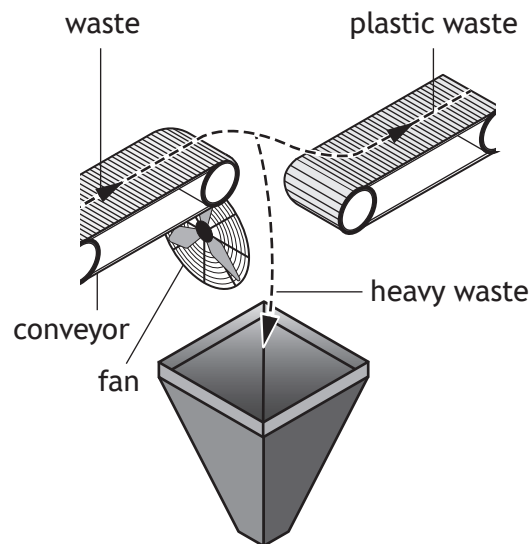

[Turn over for next question

DO NOT WRITE ON THIS PAGE



\* X 8 2 3 7 6 0 1 1 9 \*

8. (continued)

A circuit to control the action of the fan motor is shown below. The strain gauges have a resistance of  $120\ \Omega$  unless they are stretched or compressed.

Strain gauge A is used as an active strain gauge to detect the weight of the waste. Strain gauge B is used as a passive strain gauge.

When strain gauge A has a resistance of  $119\ \Omega$  the fan motor must switch on.

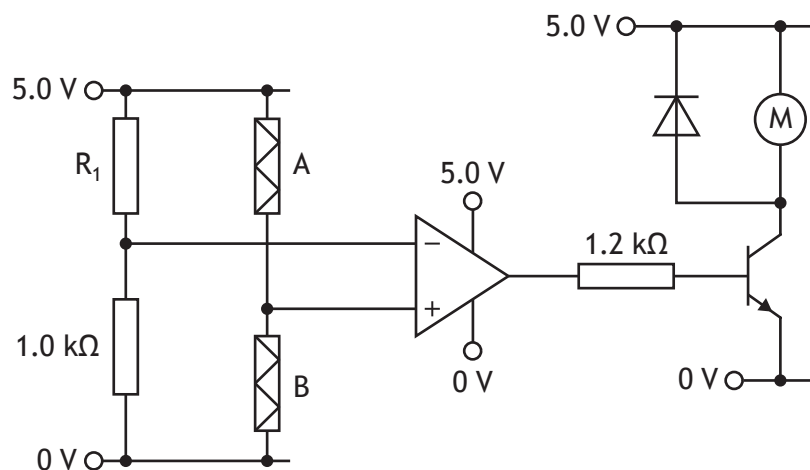

(a) Calculate the value of  $R_1$ .

2

(b) Describe the purpose of strain gauge B in this situation.

1

---



---



---



---



8. (continued)

The op-amp, in the circuit opposite, saturates at 85% of its supply voltage and the current gain ( $h_{fe}$ ) of the transistor is 320.  $V_{be}$  is 0.70 V.

(c) Calculate the collector current ( $I_c$ ) when the op-amp switches positive.

4

[Turn over



8. (continued)

MARKS DO NOT WRITE IN THIS MARGIN

After testing, it is decided that the fan motor should only operate if the weight sensed is between two set levels.

The circuit used to perform this operation is shown below.

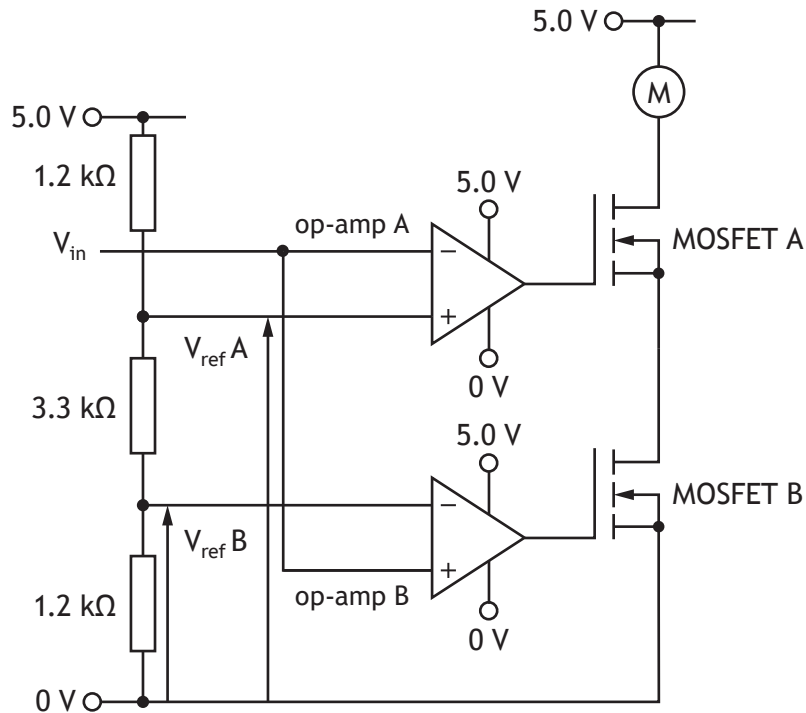

(d) Determine the range of values of  $V_{in}$  that will cause the motor to turn.

3

Range: \_\_\_\_\_

Space for working





8. (continued)

When materials have been separated, they are collected into bales and are weighed. Four sensors are used to ensure an accurate reading is achieved.

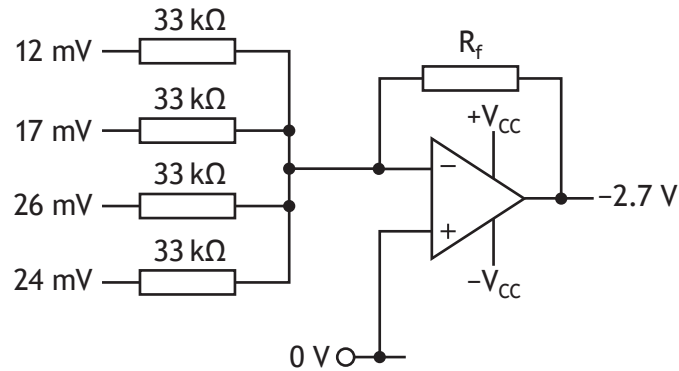

The test circuit above combines the outputs of the four sensors into one signal.

- (f) (i) Calculate  $R_f$ .

2



8. (f) (continued)

The output voltage from the circuit is required to be positive.

- (ii) Complete the circuit diagram below, to show how the output voltage could be converted to a positive value of the same magnitude. Include resistor values on your diagram.

2

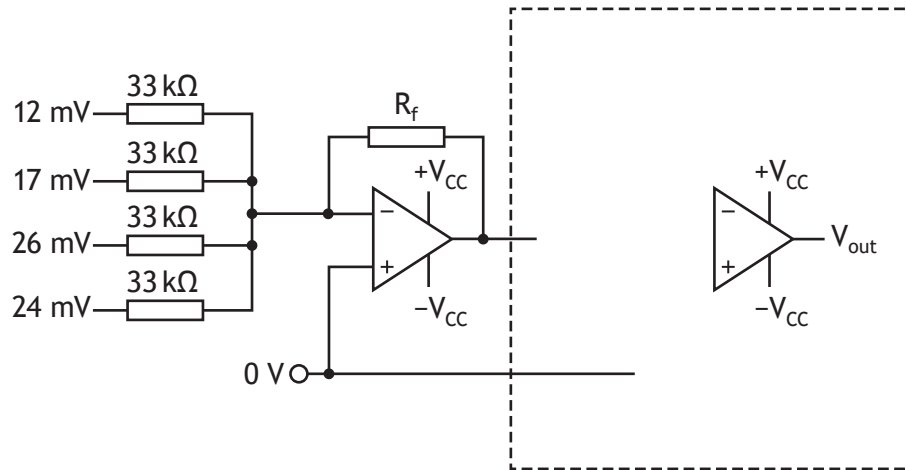

[Turn over



9. A range of street sweepers are being developed to clean outdoor areas.

MARKS DO NOT WRITE IN THIS MARGIN



The street sweeper makes use of various rotating brushes which collect dirt and debris. Each brush is connected to a plate which is driven by a motor shaft as shown below.

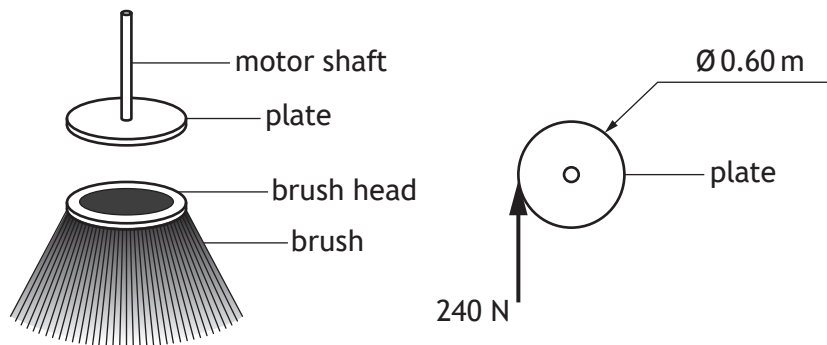

The diameter of the plate is 0.60 m and the force exerted onto the plate when the brush is in motion is 240 N. The motor is rated at 220 V, 6.6 A. Assume the system is 100% efficient.

(a) Calculate the rotational speed of the motor.

4



9. (continued)

During assembly, the plate and brush head were secured using three steel bolts. The ultimate tensile stress of the steel is  $430 \text{ Nmm}^{-2}$ .

Each bolt is initially tightened to a stress of  $5.5 \text{ Nmm}^{-2}$ . A load of  $5.0 \text{ kN}$  is then applied to each bolt adding further stress.

A factor of safety of 3.0 is applied to each bolt.

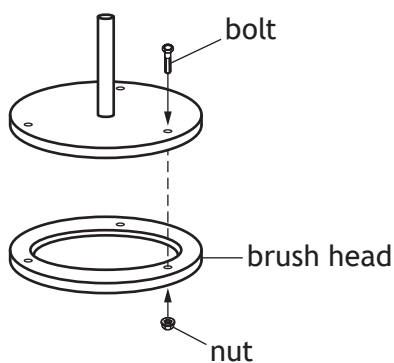

(b) Calculate the required diameter of each bolt.

4

[Turn over



9. (continued)

Water from a tank is sprayed during the cleaning process. The tank holds 2500 litres of water.

Note: 1.0 litre of water = 1.0 kg

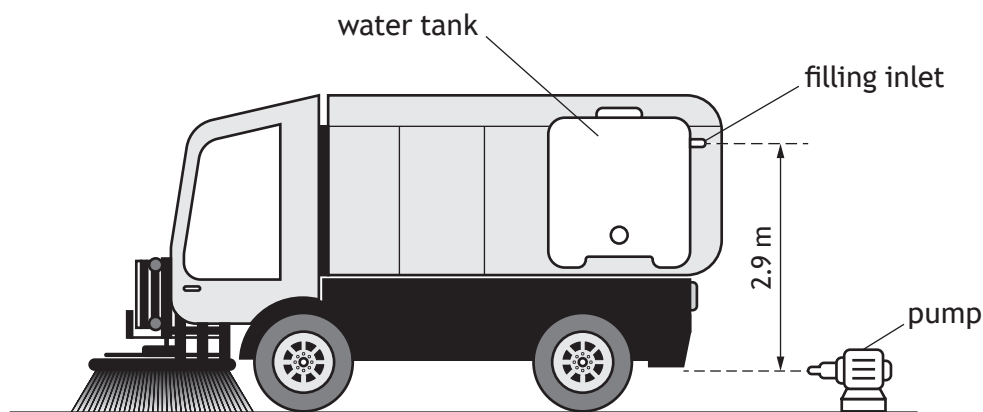

The water tank is filled using an electrical pump, rated at 230 V and 5.0 A. The pump is 87% efficient and the filling inlet is located 2.9 m above the pump.

(c) Calculate the time it will take to fill an empty tank.

4



9. (continued)

Member A is a structural member used to support and secure the empty water tank at the rear of the street sweeper.

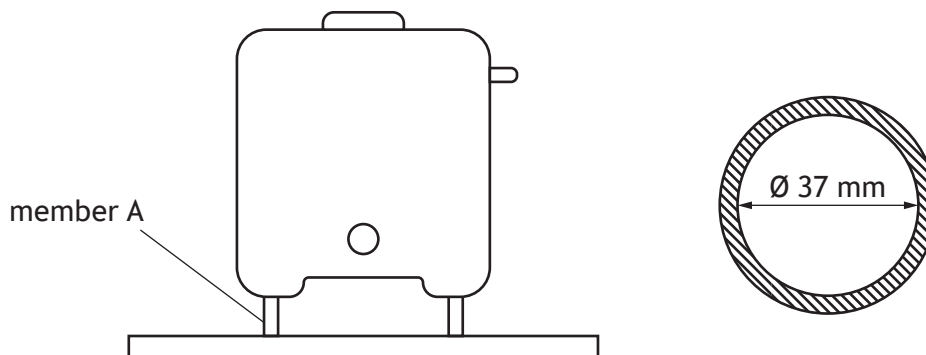

Member A is a tube with an inner diameter of 37 mm. The force from the empty water tank acting vertically on the member is 625 N and the stress present is  $3.4 \text{ Nmm}^{-2}$ .

(d) Calculate the wall thickness of member A.

5

10. A biomass plant converts waste food and other organic material into useful energy.



The waste is stored and allowed to decompose producing heat and useful gas. If it gets too hot it presents a fire hazard, so a warning system is required.

A circuit, designed to give a visual warning when the temperature is too high, is shown below.

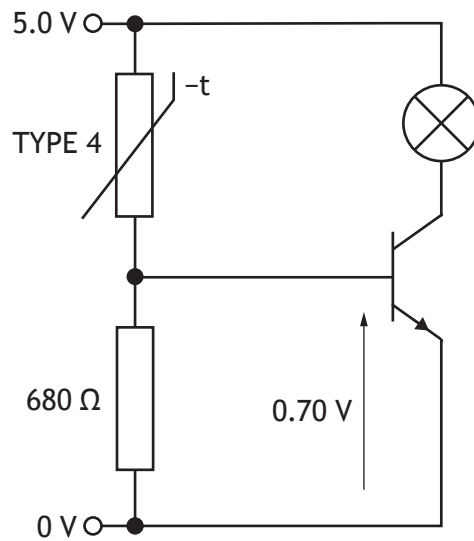

\* X 8 2 3 7 6 0 1 3 0 \*

10. (continued)

MARKS DO NOT WRITE IN THIS MARGIN

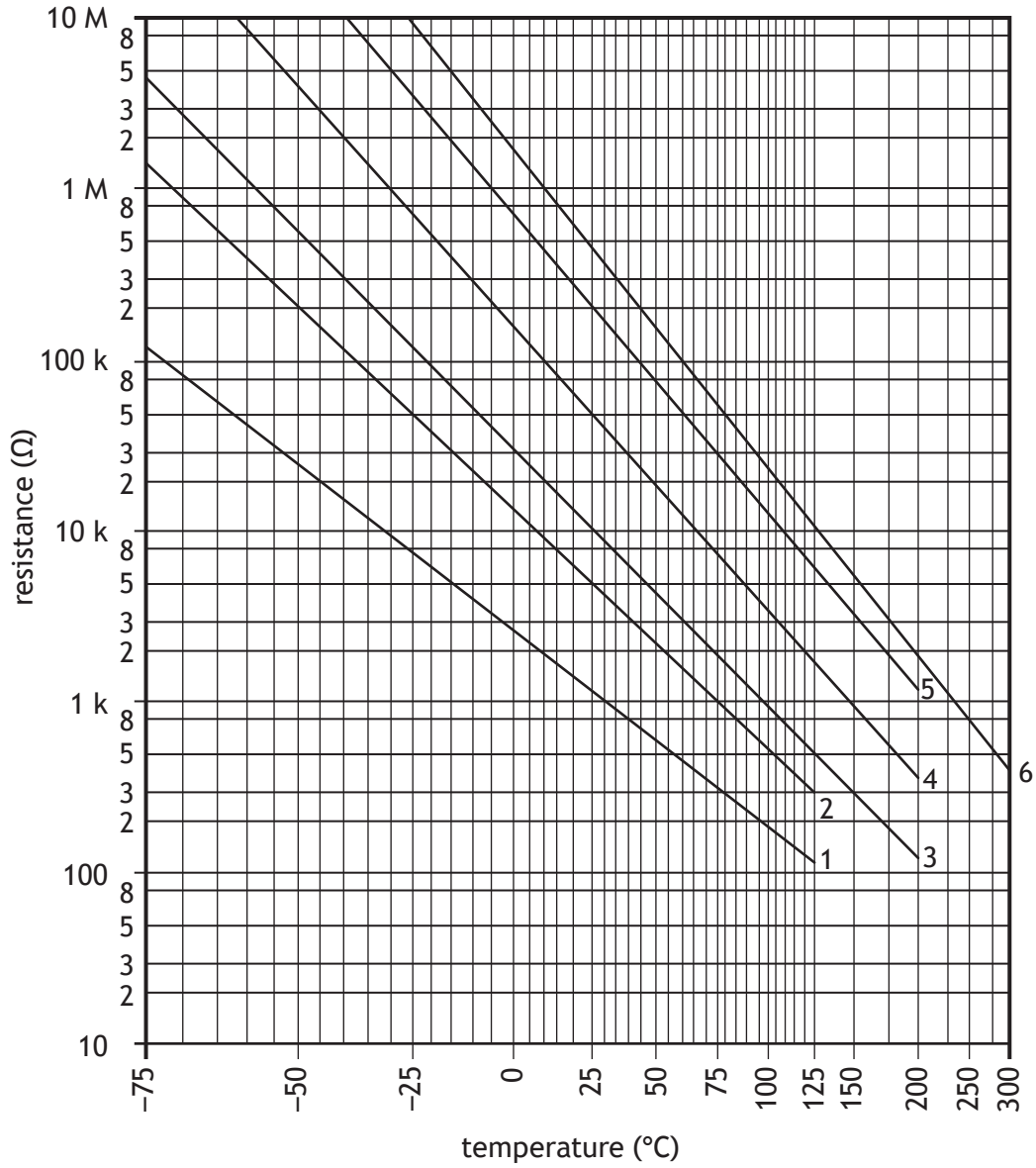

- (a) (i) Calculate the current through the thermistor when the temperature reaches 120 °C and the visual warning is on.

3



10. (a) (continued)

(ii) Calculate the base current.

2

The useful gas produced by the biomass plant is stored in canisters. An automated system is used to fit a cap onto a canister once it has been filled.

The movement of a motor involved in the process of securing the cap in place needs to be maintained at a steady speed.

(b) Explain why a two-state control system may **not** be suitable for this situation.

2

---



---



---



---



---



10. (continued)

A proportional control system is chosen for the final design to control the speed of the motor. The circuit for part of the control system is shown.

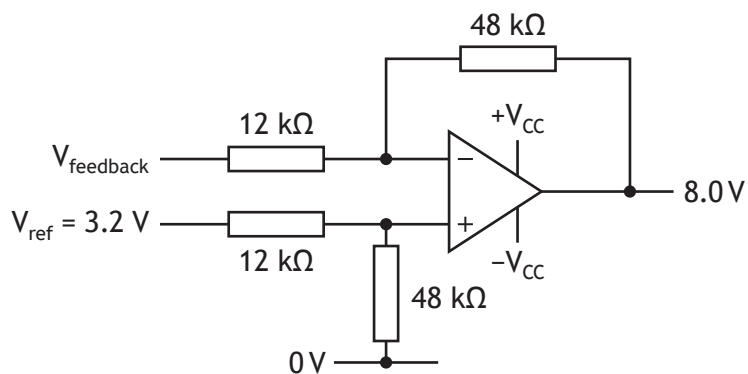

(c) Calculate the voltage from the feedback sensor.

2

[Turn over





[Turn over for next question

DO NOT WRITE ON THIS PAGE



\* X 8 2 3 7 6 0 1 3 5 \*

## 10. (continued)

Once filled, the canisters are placed in a crate to be lifted to a storage facility. Part of the lifting assembly is shown below.

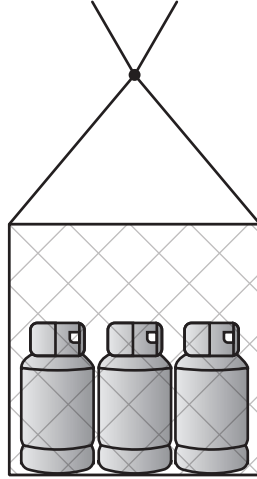

The forces acting on part of the lifting assembly are shown below.

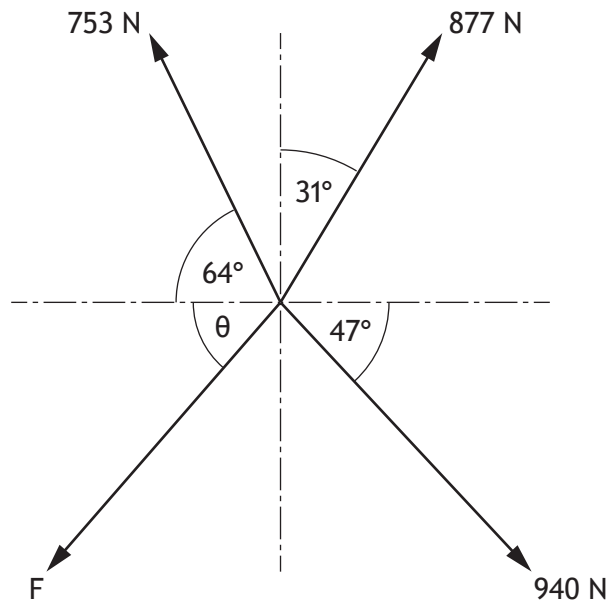

\* X 8 2 3 7 6 0 1 3 6 \*

10. (continued)

(e) Calculate the magnitude of force  $F$  and angle  $\theta$ .

6



11. As a commitment to increasing the use of electric public transport, a city is developing a railway and traffic management system.



A proposed structural design for a frame to support part of the railway is shown below. The frame is based on equilateral triangles.

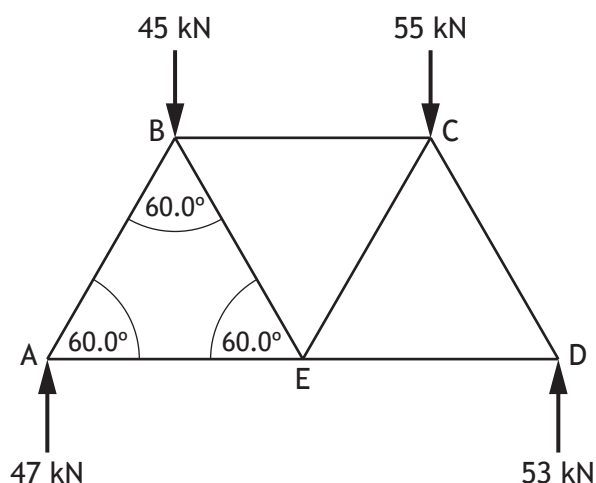

- (a) Calculate, using nodal analysis, the magnitude and nature of the forces inside members AB, AE, BE and BC.

Show all working and final units on the page opposite.

Complete the table below.

6

Member	AB	AE	BE	BC
Force				
Nature	strut	tie		



11. (a) (continued)

*Space for calculations*

node A

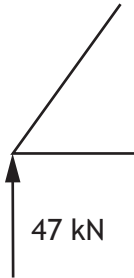

node B

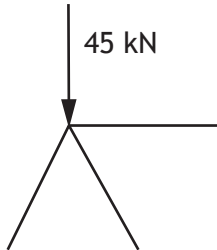

[Turn over



11. (continued)

An initial design for a control system to operate the doors on a train to be used on the railway is shown.

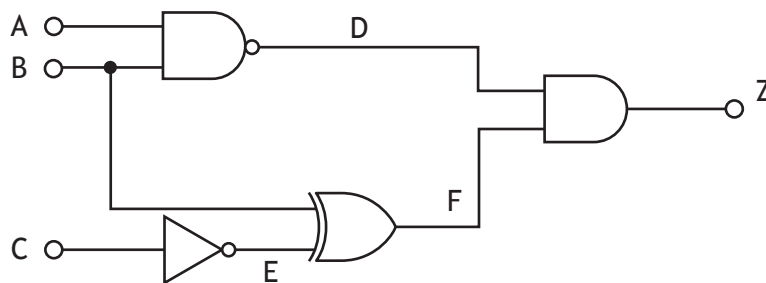

- (b) (i) Complete the truth table for the logic diagram.  
 Include the intermediate logic values for D, E, and F and the output Z. 4

A	B	C	D	E	F	Z
0	0	0				
0	0	1				
0	1	0				
0	1	1				
1	0	0				
1	0	1				
1	1	0				
1	1	1				

11. (b) (continued)

The design for a control system which operates part of the traffic management system is shown below.

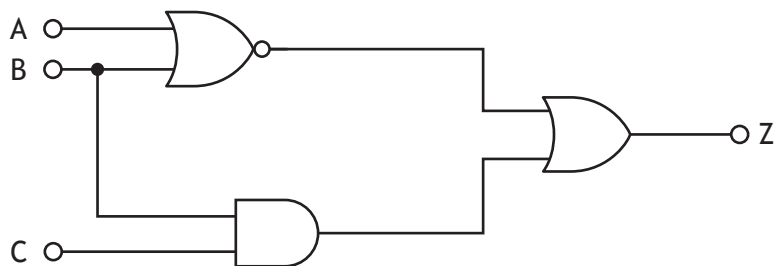

(ii) Complete a Boolean equation to describe the operation of this circuit. 3

Z = \_\_\_\_\_

(iii) Draw a NAND equivalent for this circuit. Simplify where appropriate. 4



11. (continued)

The design phase of the traffic management system was carried out by an electronic engineer.

- (c) Describe how two pieces of specialised knowledge would be used by an electronic engineer during the design phase of the traffic management system. 2

Knowledge 1 \_\_\_\_\_

\_\_\_\_\_

\_\_\_\_\_

Knowledge 2 \_\_\_\_\_

\_\_\_\_\_

\_\_\_\_\_

Teams of engineers are also working on improvements to cycle lanes and footpaths throughout the city.

- (d) Describe two ways these improvements would have a positive social impact on those who live in, work in, or visit the city. 2

Impact 1 \_\_\_\_\_

\_\_\_\_\_

\_\_\_\_\_

\_\_\_\_\_

Impact 2 \_\_\_\_\_

\_\_\_\_\_

\_\_\_\_\_

\_\_\_\_\_

[END OF QUESTION PAPER]



MARKS DO NOT  
WRITE IN  
THIS  
MARGIN

ADDITIONAL SPACE FOR ANSWERS



\* X 8 2 3 7 6 0 1 4 3 \*

MARKS DO NOT  
WRITE IN  
THIS  
MARGIN

ADDITIONAL SPACE FOR ANSWERS



\* X 8 2 3 7 6 0 1 4 4 \*

[BLANK PAGE]

DO NOT WRITE ON THIS PAGE



\* X 8 2 3 7 6 0 1 4 5 \*

[BLANK PAGE]

DO NOT WRITE ON THIS PAGE



\* X 8 2 3 7 6 0 1 4 6 \*

[BLANK PAGE]

DO NOT WRITE ON THIS PAGE



\* X 8 2 3 7 6 0 1 4 7 \*

[BLANK PAGE]

DO NOT WRITE ON THIS PAGE

*Acknowledgement of copyright*

Question 1	Daniel Jedzura/shutterstock.com
Question 2	SB_photos/shutterstock.com
Question 4	chuyuss/shutterstock.com
Question 6	Value ho/shutterstock.com
Question 8	Nordroden/shutterstock.com
Question 9	Mike_shots/shutterstock.com
Question 10	Kletr/shutterstock.com
Question 11	Sergio Photone/shutterstock.com



\* X 8 2 3 7 6 0 1 4 8 \*