



Higher
Coursework
Assessment Task



Higher Engineering Science Assignment

Assessment task: Motor Racing Team

Valid for session 2024-25 only.

This is given to centres in strictest confidence. You must keep it in a secure place until it is used.

This edition: January 2025 (version 1.0)

© Scottish Qualifications Authority 2025

Contents

Introduction	2
Instructions for teachers and lecturers	3
Instructions for candidates	6

Introduction

This document contains instructions for teachers, lecturers, and candidates for the Higher Engineering Science assignment. It must be read in conjunction with the course specification.

There is an additional document that contains the worksheets for this assignment.

This assignment has 50 marks out of a total of 160 marks available for the course assessment.

This is one of two course assessment components. The other component is a question paper.

Whilst this document contains 'instruction for teachers and lecturers' and 'instructions for candidates', everything in the document can be given to candidates.

Instructions for teachers and lecturers

This assignment is valid for the current session only.

Assessment conditions

You must conduct the assignment under a high degree of supervision and control. This means:

- ◆ all candidates must be within your direct sight
- ◆ candidates must not interact with each other
- ◆ candidates must not have access to email, the internet or mobile phones
- ◆ candidates must complete their work independently – no group work is permitted
- ◆ classroom display materials that might provide assistance must be removed or covered
- ◆ there must be no interruption for learning and teaching
- ◆ candidates must be in a classroom environment

Duration

Candidates have 8 hours to complete the assignment, starting at an appropriate point in the course after all content has been delivered. Once candidates begin their assignment, they must continue in each subsequent class period until the permitted time allocation has been used up.

You have a responsibility to manage candidates' work, distributing it at the beginning and collecting it at the end of each class period, and storing it securely in-between. This activity does not count towards the total time permitted for candidates to complete the assignment.

Resources

This is a closed-book assessment. Candidates must not have access to learning and teaching materials, the internet, notes, exemplar materials, resources on classroom walls or anything similar.

A data booklet containing relevant data and formulae is available on the Higher Engineering Science subject page on SQA's website. This can be used for the assignment.

Each assessment task includes instructions and details of any equipment or materials required for the assignment. Candidates can also use normal classroom equipment, software and hardware (such as drawing instruments, pneumatics, mechanisms and electronics kit, simulation software, and PCs to run the software) to complete the tasks.

There may be instances where restriction of internet and/or network use is not practical or feasible (for example, a local authority-managed IT network with specific limitations, software that is web-based, or something similar), however, it remains your professional responsibility to make every effort to meet the assessment conditions.

Alteration or adaptation

You must not alter, adapt or modify the assignment in any way – this includes moving the content into a different format. All candidates must undertake the assignment exactly as it has been provided by SQA.

Reasonable assistance

Candidates must progress through each stage of the assignment without your intervention or guidance, having acquired the skills needed earlier in the course.

Once candidates complete the assignment, you must not return it to them for further work. You must not provide feedback to candidates or offer your opinion on the perceived quality or completeness of the assignment response at any stage.

You can provide reasonable assistance to support candidates with the following aspects of their assignment:

- ◆ printing, collating and labelling their evidence to ensure it is in the format specified by SQA
- ◆ ensuring candidates have all the materials and equipment required to complete the assignment
- ◆ understanding the information outlined in these instructions

Artificial Intelligence

This is not permitted. Please see SQA's website for more information, if needed.

Evidence

This assignment will be electronically marked from image (MFI).

You must ensure that all candidate evidence (whether created manually or electronically) is:

- ◆ clear and easy to read (anything handwritten or drawn must be in blue or black permanent ink only)
- ◆ without anything else fixed to the pages (for example, photographs glued in place)
- ◆ labelled at the top to show the task that it refers to
- ◆ labelled at the bottom to show the candidate's Scottish Candidate Number (SCN)
- ◆ compiled in task order with our flyleaf as the front cover
- ◆ printed or presented on A4 paper and secured with a single staple in the top left corner (prints can be single-sided or double-sided, however we prefer double-sided)

Each task must have a hard copy output (printed or hand-written) and each page of the candidate response must note the task number at the top of the page and their Scottish Candidate Number (SCN) at the bottom of the page. This includes where the task asks them to simulate, construct, code, or similar.

Assignment

This assignment contains a number of tasks. Each task details:

- ◆ what the candidate must do (including any specific instructions on how the task must be carried out)
- ◆ how many pages of evidence are expected
- ◆ an anticipated duration

This ensures that candidates understand how to approach the tasks and do not produce too much or spend too long on a single task (whilst there is a time limit for the assignment, there is no page limit or page count).

Candidates can complete the tasks in the order presented or in an order that helps you manage classroom equipment and resources.

You must ensure that candidates are aware of the assessment conditions for the assignment, and that they understand what they should do for each task.

Instructions for candidates

This assignment has 50 marks out of a total of 160 marks available for the course assessment.

This is a closed-book assessment. Your teacher or lecturer lets you know how to carry out the assignment and they will go over the assessment conditions.

The assignment has a number of tasks and for each task you are provided with an engineering science context or situation.

In this assignment, you have to:

- ◆ analyse a problem
- ◆ design a solution to the problem
- ◆ build (simulate or construct) your solution
- ◆ test your solution
- ◆ evaluate your work

Unless otherwise instructed, you should complete all of the tasks in the order presented.

Each task must have a hard copy output (printed or hand-written) and each page of your response must note the task number at the top of the page and your Scottish Candidate Number (SCN) at the bottom of the page. This includes where the task asks you to simulate, construct, code, or similar.

You have 8 hours to complete the assignment. The time to set up and clear away any equipment you will need, and for any printing that is necessary, does not count towards the 8 hours.

Data sheets

You can use these data sheets and SQA's Higher Engineering Science data booklet when completing this assignment. **No other resource material is permitted.**

Electronic symbols

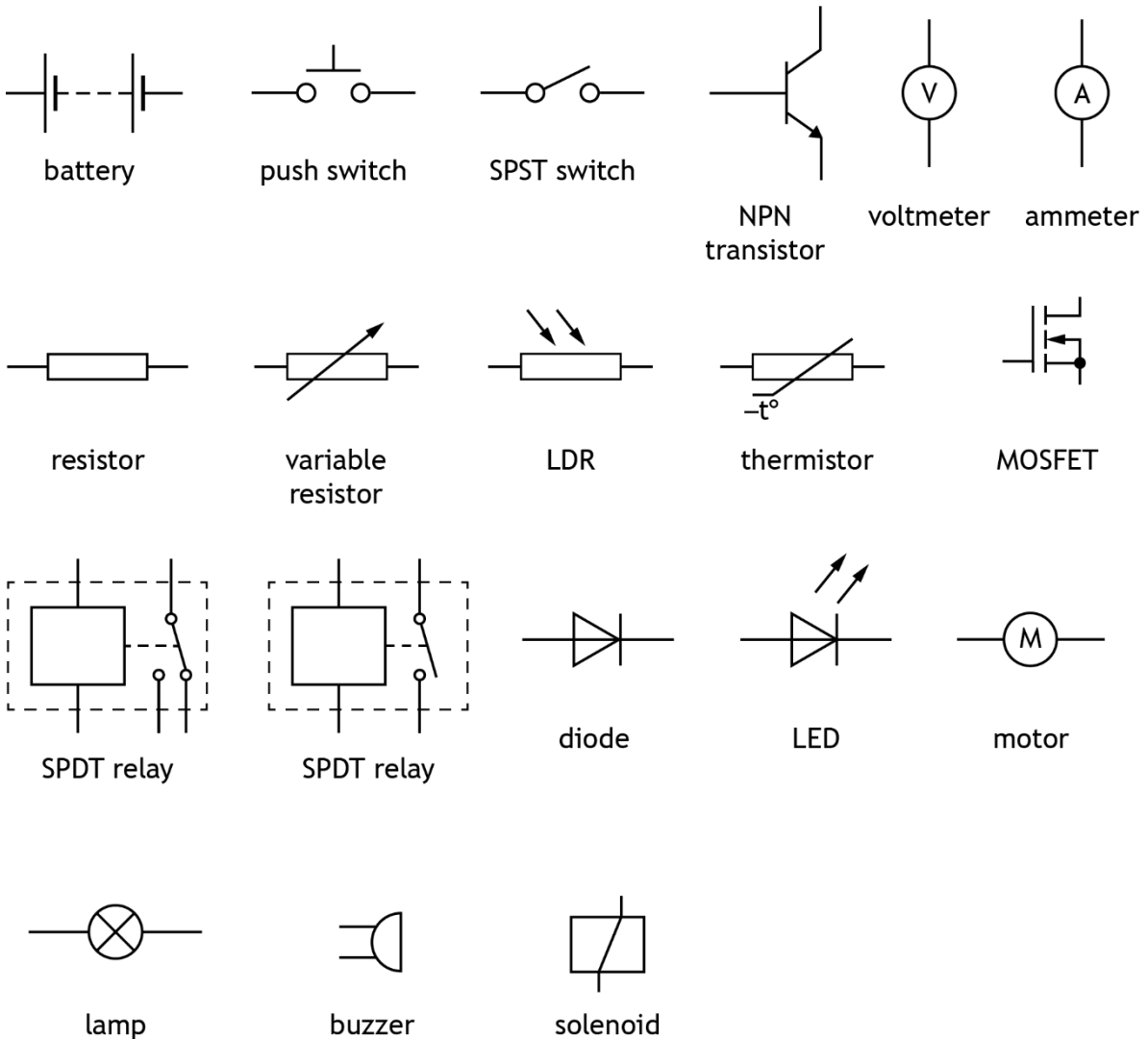

Electronic symbols (continued)

IC pinout diagrams

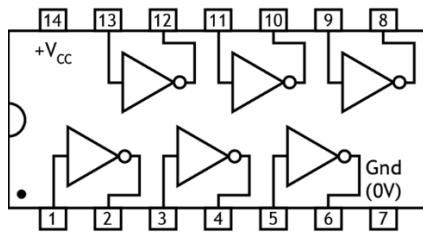

7404

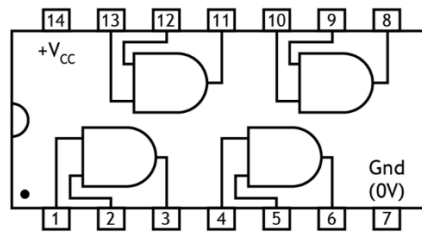

7408

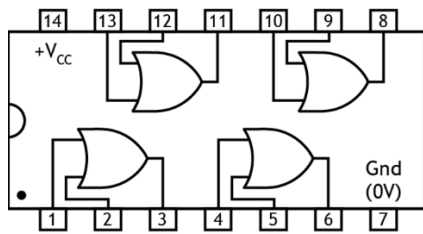

7432

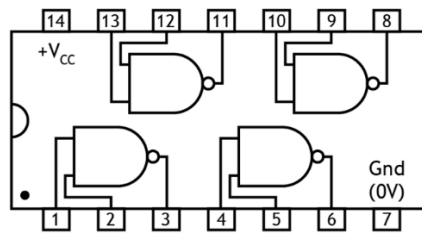

7400

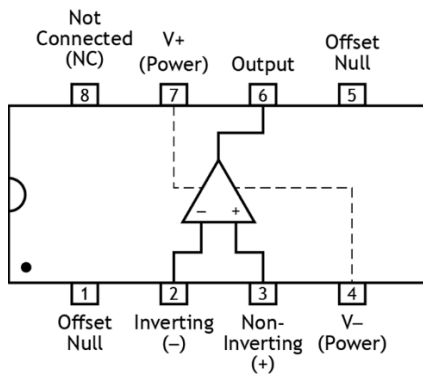

741

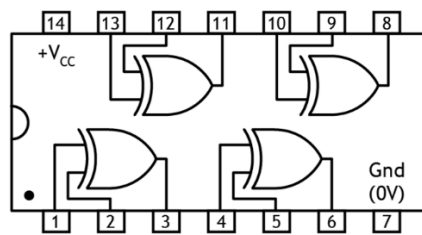

7486

Logic gates

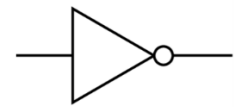

NOT gate

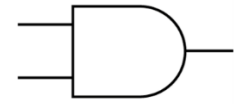

AND gate

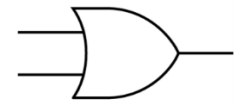

OR gate

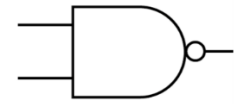

NAND gate

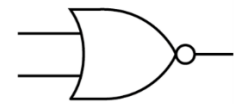

NOR gate

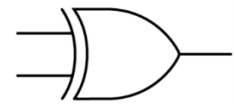

XOR gate

Thermistor graph

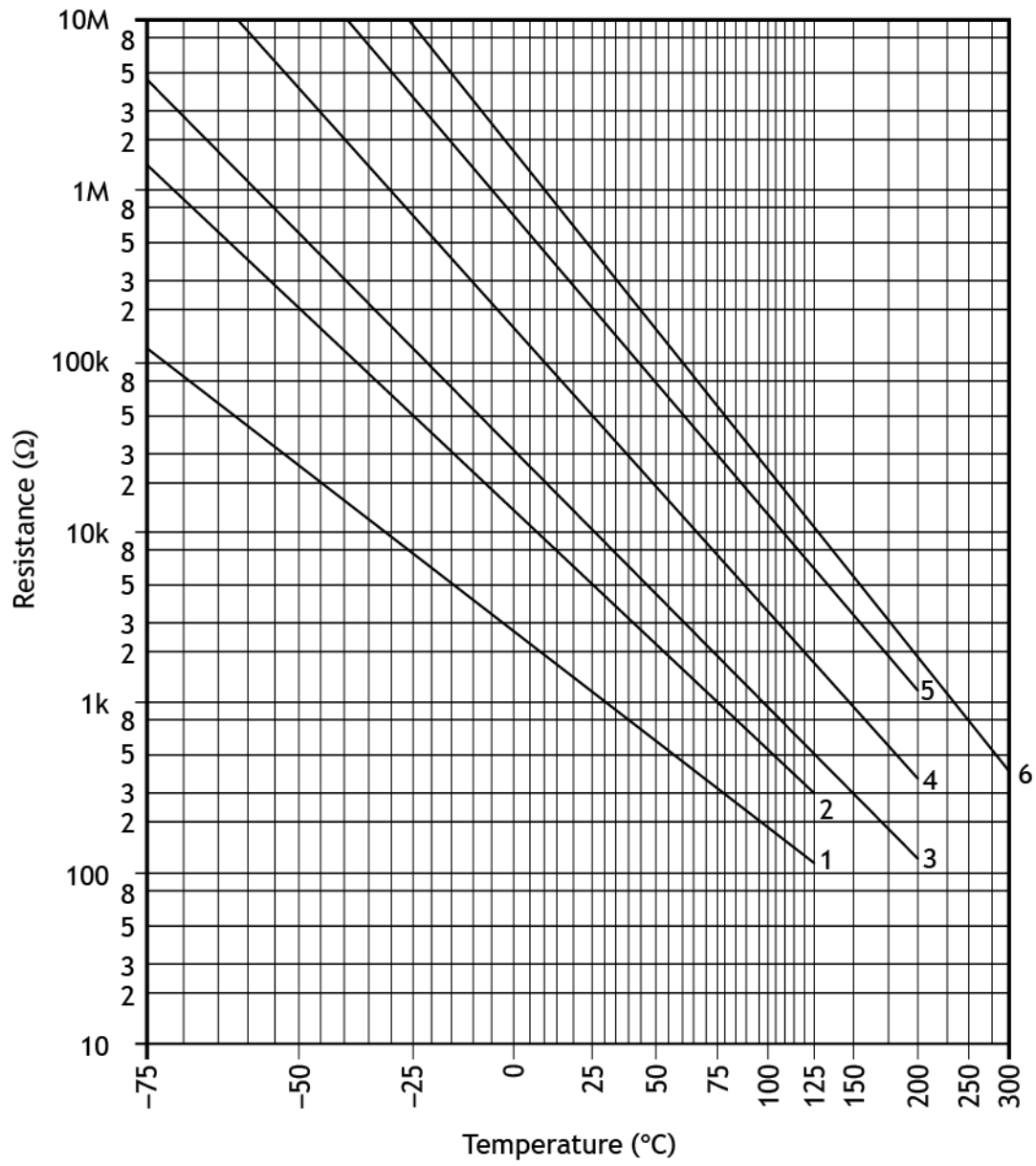

Light Dependent Resistor (LDR) graph for an ORP12 LDR

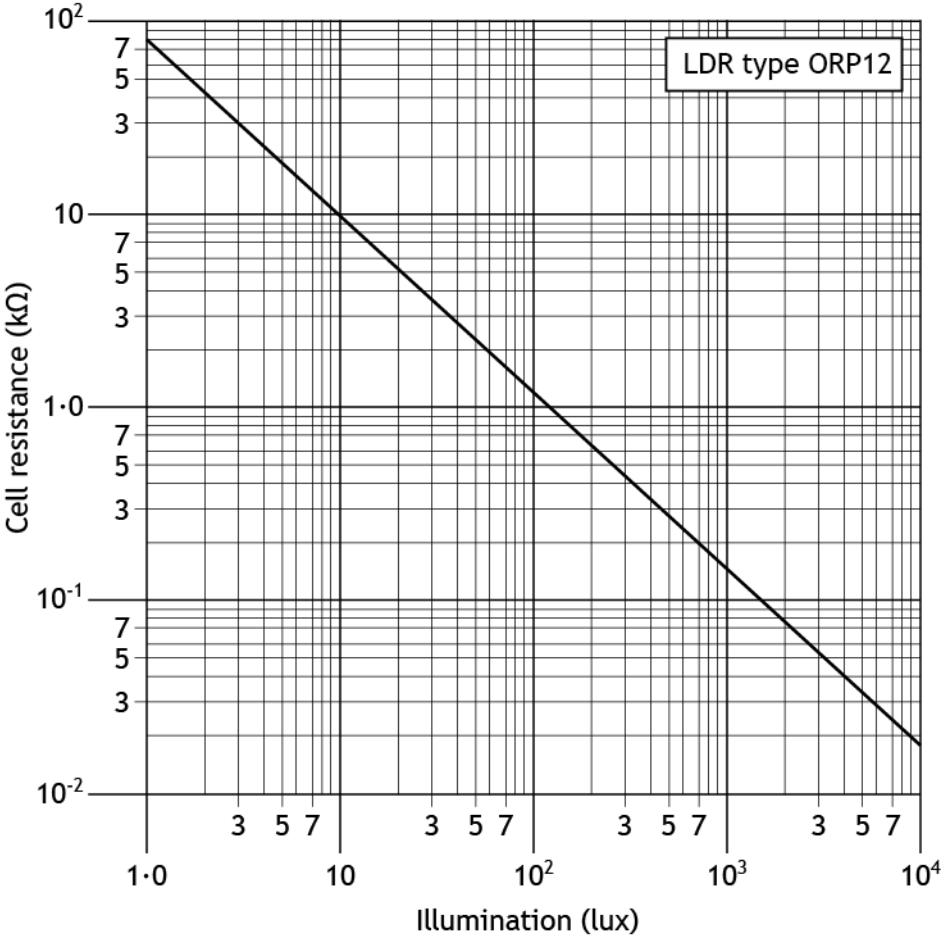

Pneumatic symbols

Actuators



spring return



pilot air



roller



solenoid



lever



diaphragm



roller trip



plunger



push button



foot pedal

Valves

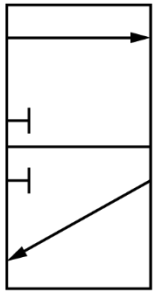

3/2 valve

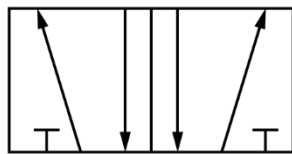

5/2 valve

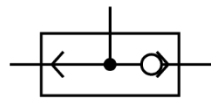

shuttle valve



main air



exhaust

Components and cylinders

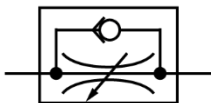

unidirectional restrictor

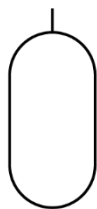

reservoir

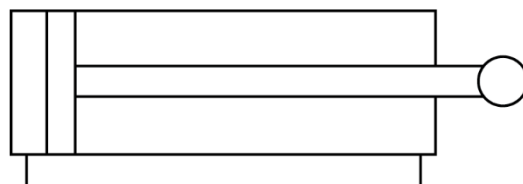

double-acting cylinder



T-piece

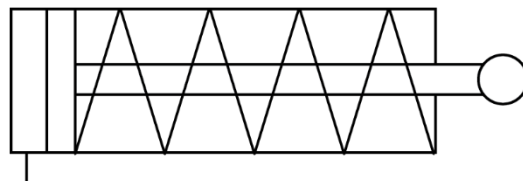

single-acting cylinder

Assignment - Motor racing team

A team of engineers is involved in several tasks during the design, construction and maintenance of a motor racing car.

The tasks include the development of the following proposals:

- ◆ Task 1 – team garage
- ◆ Task 2 – race car test system
- ◆ Task 3 – monocoque
- ◆ Task 4 – anti-lock braking system
- ◆ Task 5 – race control warning system

Task 1 – team garage

- ◆ Notional time: 2 hours 15 minutes
- ◆ Volume: completed on up to five single-sided A4 pages
- ◆ Worksheet: provided for tasks 1b and 1e

An electronically controlled lifting platform is designed to allow mechanical engineers access to the underside of a car.

A mechanical engineer has designed a pneumatic circuit to raise and lower the lifting platform, controlled by the output from an electronic circuit.

The pneumatic circuit must operate to the following specification:

- When the solenoid is energised, a 3/2 valve sends a time delayed pilot signal to a 5/2 control valve, outstroking two double-acting cylinders simultaneously to lift the platform.
- The time delayed pilot signal must be controllable.
- When a push button is pressed on a second 3/2 valve, the two double-acting cylinders instroke simultaneously to lower the lift slowly and smoothly.

A diagram of the mechanical engineer's circuit is shown below:

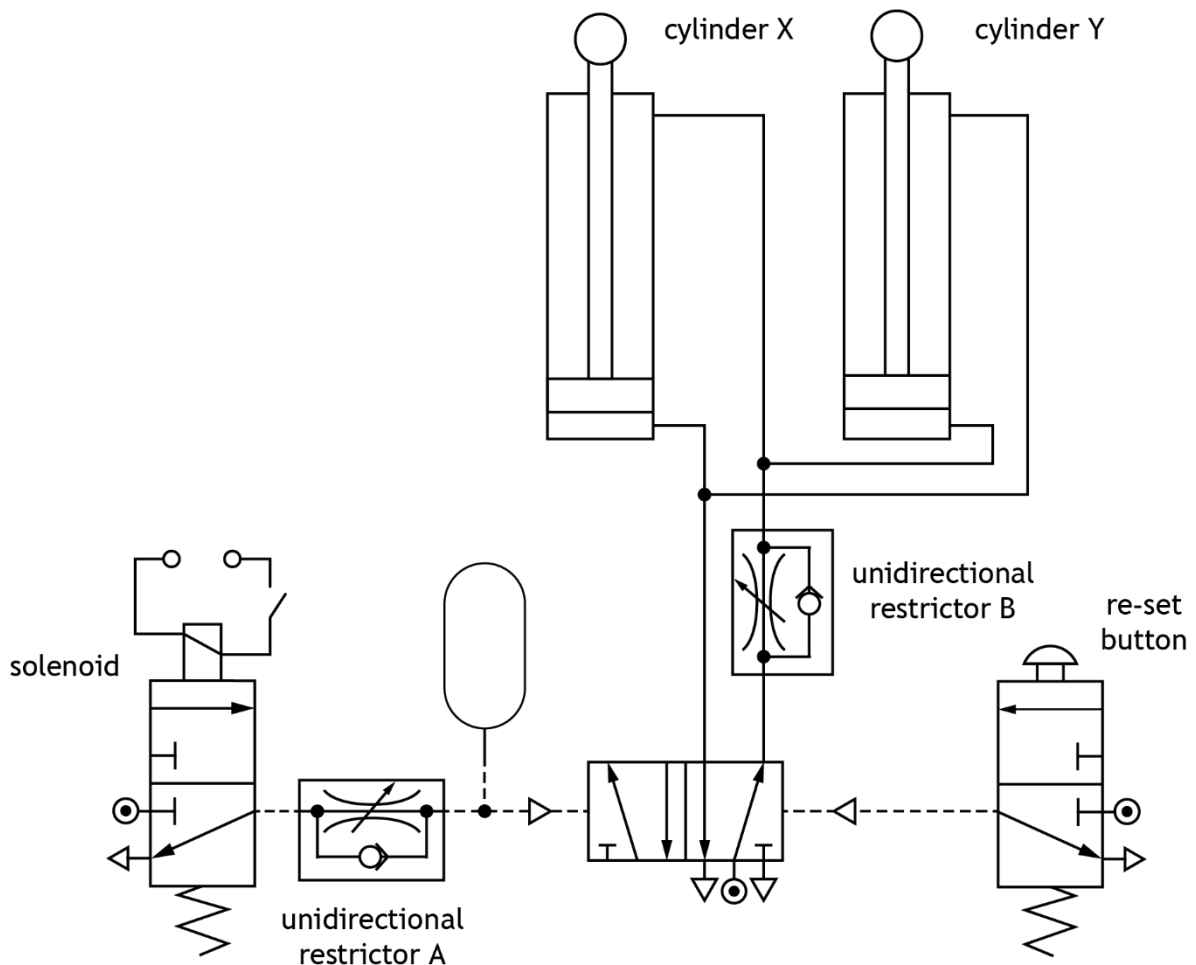

Task 1 – team garage (continued)

- 1a Simulate or construct the pneumatic circuit as shown in the diagram on the previous page. Do not turn on main air at this point.

If pneumatic components have been used in a circuit construction, all piping between components must be easily identifiable and followed. Annotations and/or the use of different coloured piping may aid this.

If the correct component is not available, you may substitute it for another component to ensure the circuit can be tested in **task 1b**. You must label any substituted components and unidirectional restrictor orientation clearly in your evidence.

Produce a hard copy output of your simulation or construction. You must note the task number at the top of the page and your Scottish Candidate Number (SCN) at the bottom of the page. **(4 marks)**

- 1b Complete the test plan given on **worksheet 1b** by carrying out the planned tests, making amendments as necessary before moving onto the next test.

You must write descriptions of the actual results you observed during the testing and any appropriate amendments that you made to enable the system to meet the specification.

Produce a hard copy output of your circuit following amendments after testing (clearly showing and annotating all amendments, and indicating the unidirectional restrictor orientation). You must note the task number at the top of the page and your Scottish Candidate Number (SCN) at the bottom of the page. **(6 marks)**

- 1c Evaluate the performance of your amended solution from **task 1b** against the specification for the pneumatic circuit. Describe the performance of your amended solution to meet each of the three specification points, referring to testing and any amendments that you may have made.

Produce a hard copy output of your evaluation. You must note the task number at the top of the page and your Scottish Candidate Number (SCN) at the bottom of the page. **(3 marks)**

Task 1 – team garage (continued)

An electronic engineer designs a circuit that will be used to sense when a car is in position on the lifting platform to energise the solenoid in the pneumatic system. The circuit must meet the following specification:

- i The circuit must make use of two different operational amplifier configurations.
- ii Four switches must be used to simulate sensing the positions of all four wheels.
- iii When one front wheel is in position the output voltage, V_o , will be 2 V.
- iv When one rear wheel is in position the output voltage, V_o , will be 4 V.
- v When all four wheels are in position the output voltage, V_o , will be 12 V.

6V ○—

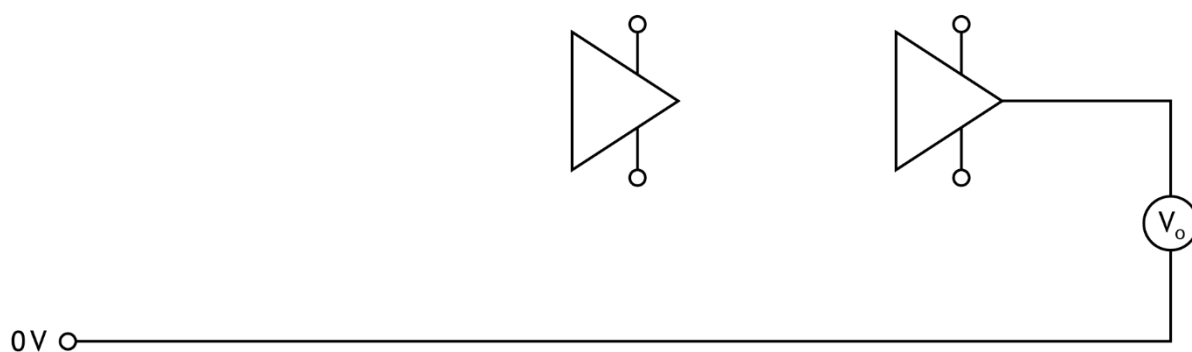

1d Simulate or construct an electronic circuit to meet this specification.

A partial circuit diagram is given above to aid your planning.

Produce a hard copy output of your simulation or construction. You must note the task number at the top of the page and your Scottish Candidate Number (SCN) at the bottom of the page. **(6 marks)**

Task 1 – team garage (continued)

1e Design a test plan for the electronic circuit, by completing the test table on **worksheet 1e**.

You must include a planned test and expected result for:

- ◆ when both front wheels are in place
- ◆ when both rear wheels are in place
- ◆ all four wheels are in place.

You must refer to the expected voltmeter reading from the electronic circuit in **task 1d** in your testing. **(3 marks)**

Task 2 – race car test system

- ◆ Notional time: 30 minutes
- ◆ Volume: completed on up to one single-sided A4 pages
- ◆ Worksheet: provided for task 2

The mechanical engineers need to test the car while preparing for the next race.

They require a system to test the performance of the axles during racing conditions. They use motorised rollers to rotate the car's wheels, causing the axle to rotate. The system controls the speed of the rollers during testing.

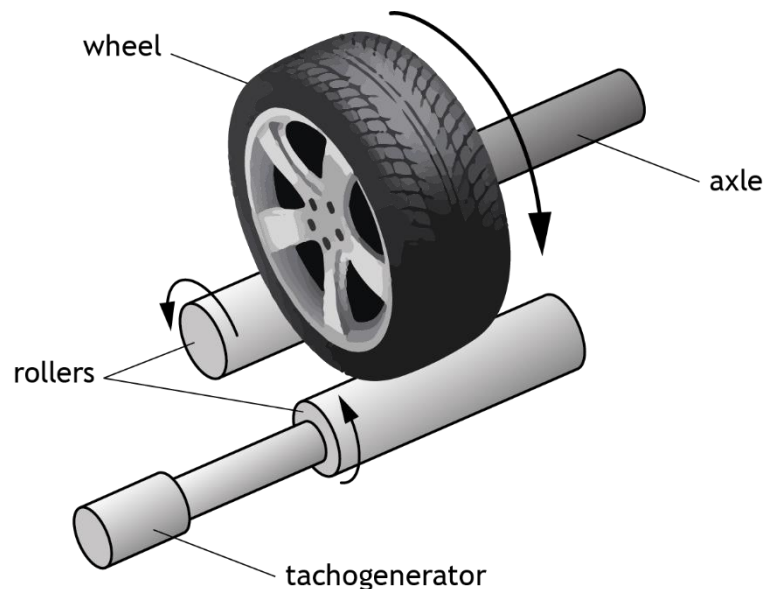

The system must meet the following specification:

- The mechanical engineers set the desired roller motor speed.
 - Whenever the speed rises above the desired level, the roller motor speed decreases.
 - Whenever the speed drops below the desired level, the roller motor speed increases.
 - The roller motor speed is monitored by a tachogenerator.
- 2 Analyse this specification by completing, on **worksheet 2**, a control diagram for the race car test system. **(6 marks)**

Task 3 – monocoque

- ◆ Notional time: 45 minutes
- ◆ Volume: completed on up to two single-sided A4 pages
- ◆ Worksheet: provided for tasks 3a and 3b

The material performance of the monocoque (the protective shell the driver sits in, shown below) is of high importance for the driver's safety.

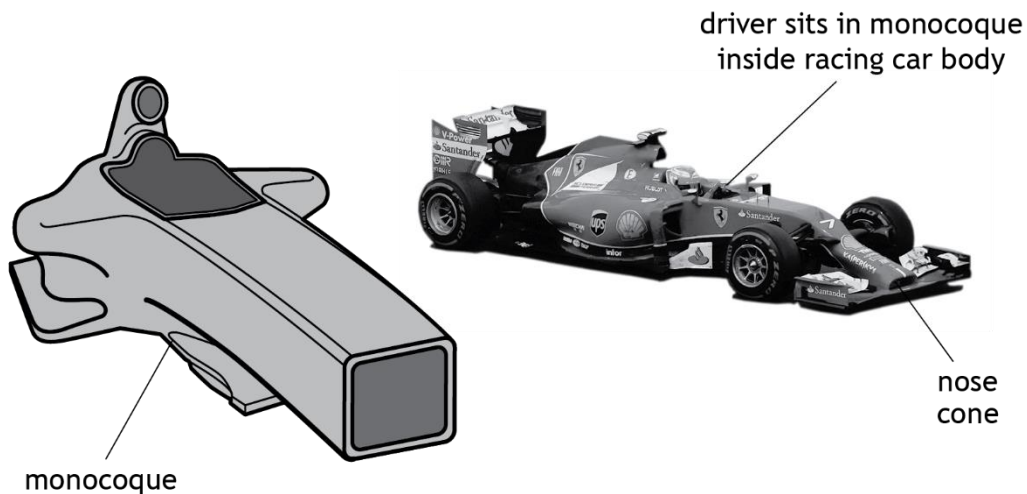

To comply with safety rules, the materials used must meet the following specification:

- The material must be strong enough to withstand the stress caused by the nose cone of another car (250 kN on the area of a 150 mm diameter circle).
- The material must remain elastic over the first 100 mm of deflection on impact.
- The material must have high energy absorption properties.
- The material must be as lightweight as possible.

Four materials are considered for the new design. A range of information about the materials is shown on the following page.

Note: energy absorption for each material directly relates to the area under the graph.

Task 3 – monocoque (continued)

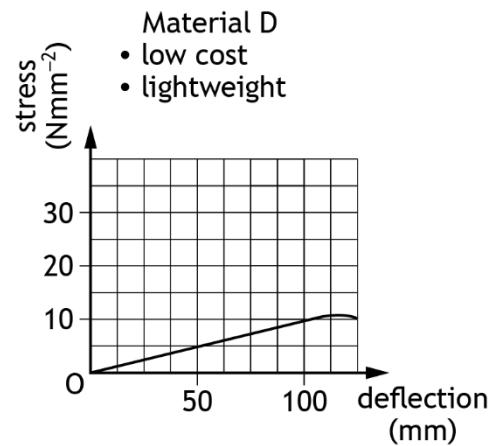
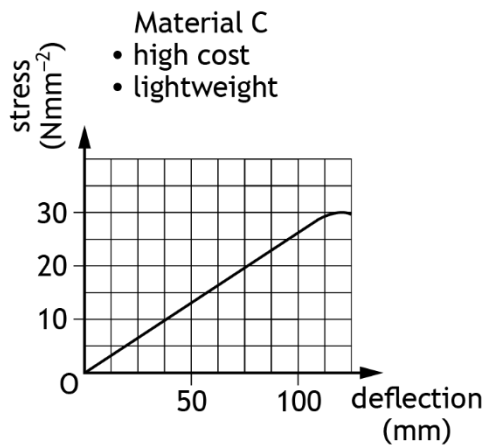
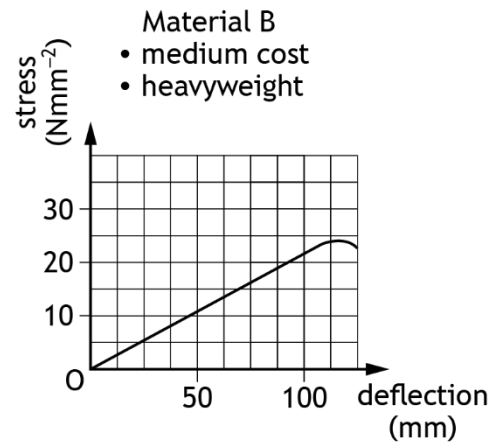
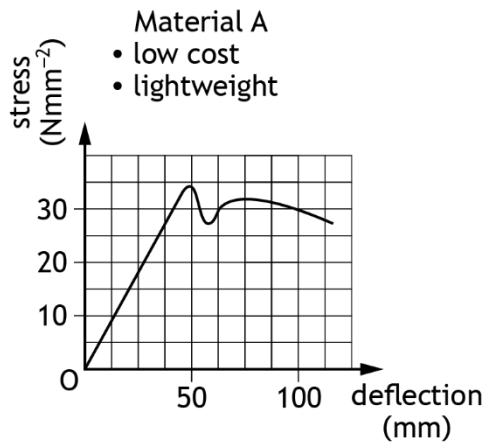

- 3a Evaluate, by comparison, the materials above by completing **worksheet 3a**. (4 marks)
- 3b State the most appropriate material for the new monocoque by completing **worksheet 3b** and justify your choice. (1 mark)

Task 4 – anti-lock breaking system

- ◆ Notional time: 30 minutes
- ◆ Volume: completed on up to one single-sided A4 page
- ◆ **You must not use simulation software, an integrated development environment (IDE), or pseudocode to complete task 4**
- ◆ **You must identify the code you use if it is not PBASIC or Arduino C++.**

A microcontroller-operated anti-lock braking system (ABS) has been designed for the racing car.

The ABS operates by pulsing a brake actuator on and off. This prevents the car from skidding in hard braking situations.

An electronic engineer is testing high-level program code for pulse-width modulation to control the brake actuator.

The code written to perform this task is:

PBASIC

```
symbol mark = b1
symbol space = b2
symbol brake = B.7

let mark = 10
let space = 20

label:
if pin0 = 0 then label

main:
high brake
pause mark
low brake
pause space
goto main
```

Arduino C++

```
int brake = 7
int pin0 = 0

void setup(){
  pinMode(brake,OUTPUT);
  pinMode(pin0,INPUT);
}

if(digitalRead(pin0)==LOW){
  digitalWrite(brake,LOW;}
else

void loop()
{
  digitalWrite(brake,HIGH);
  delay(10);
  digitalWrite(brake,LOW);
  delay(20);
}
```

Task 4 – anti-lock breaking system (continued)

After testing, the coding is to be changed to meet the following specifications:

- i The brake actuator is connected to pin 5 of the microcontroller.
 - ii The pulse-width modulation routine must only be executed while pin 0 is active.
 - iii A mark:space ratio of 1:4 is applied in the code.
 - iv The code must run continuously.
- 4 Edit the high-level program code, given on the previous page, in a language you are familiar with to meet the specification for the ABS.

You must not use simulation software, an integrated development environment (IDE), a flowchart, or pseudocode to complete this task.

You must identify the code you use if it is not PBASIC or Arduino C++.

Produce a hard copy output of your code. You must note the task number at the top of the page and your Scottish Candidate Number (SCN) at the bottom of the page.

(3 marks)

Task 5 – race control warning system

- ◆ Notional time: 4 hours
- ◆ Volume: completed on up to four single-sided A4 pages
- ◆ Worksheet: provided for task 5c
- ◆ **You must ensure that appropriate maximum ratings for components are used for task 5b**

All racing tracks used during the season must have an electronic warning system to control the behaviour of the drivers during the race.

For a race to proceed, the race controller and the weather station must agree that conditions are safe.

Racing cannot continue when the safety car is on the track.

The table below shows the input conditions for racing.

	High	Low
Race controller	Not safe	Safe
Weather station	Not safe	Safe
Safety car	Off track (safe)	On track (not safe)

The specification for a digital electronic race control warning system is given below.

The race control warning system must activate:

- When the race controller and the weather station indicate that conditions are not safe.
- Or when the safety car is on the track.

5a Design a digital logic circuit to meet this specification. The circuit must use the least number of logic gates possible.

You may use simulation software to complete this task.

Produce a hard copy output of your design. You must note the task number at the top of the page and your Scottish Candidate Number (SCN) at the bottom of the page.

(3 marks)

Task 5 – race control warning system (continued)

It is decided that a programmable microcontroller system is to be used to give more flexibility and adaptability in the race control system.

The initial design for the microcontroller system and the flowchart program is shown below.

Input	Pin	Output
	7	Mechanical blind
	6	Tracking lighting
	5	Red LED
	4	Green LED
Lap counter switch	2	
Race controller's start switch	1	
Light sensor	0	

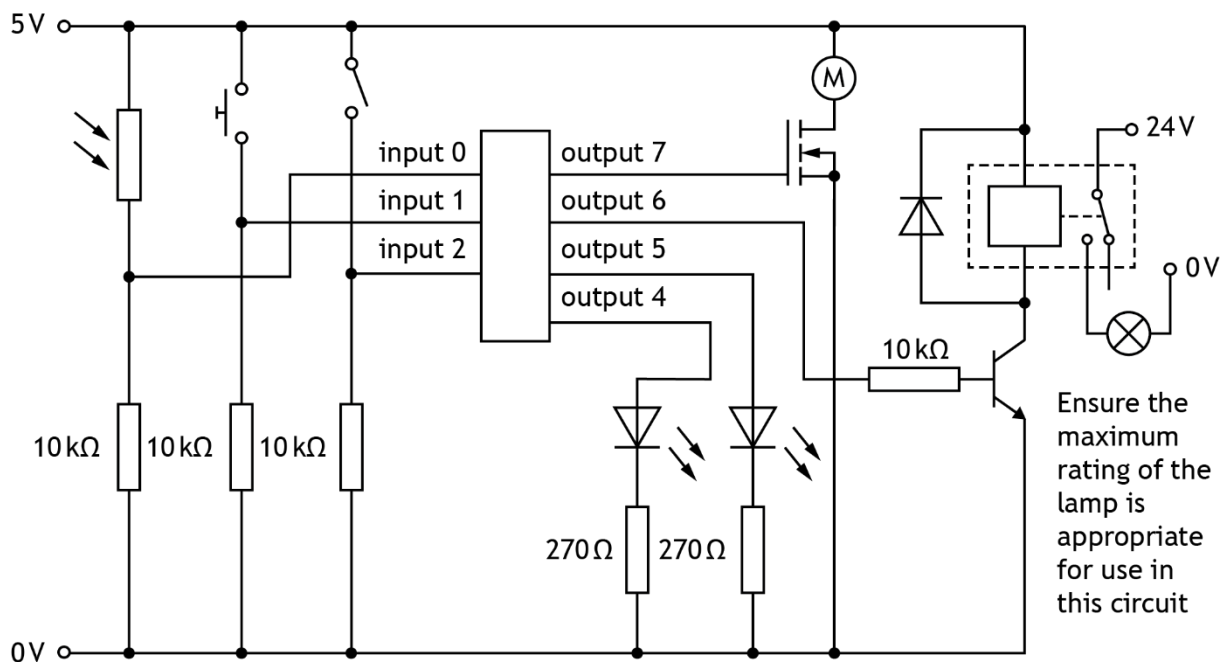

Task 5 – race control warning system (continued)

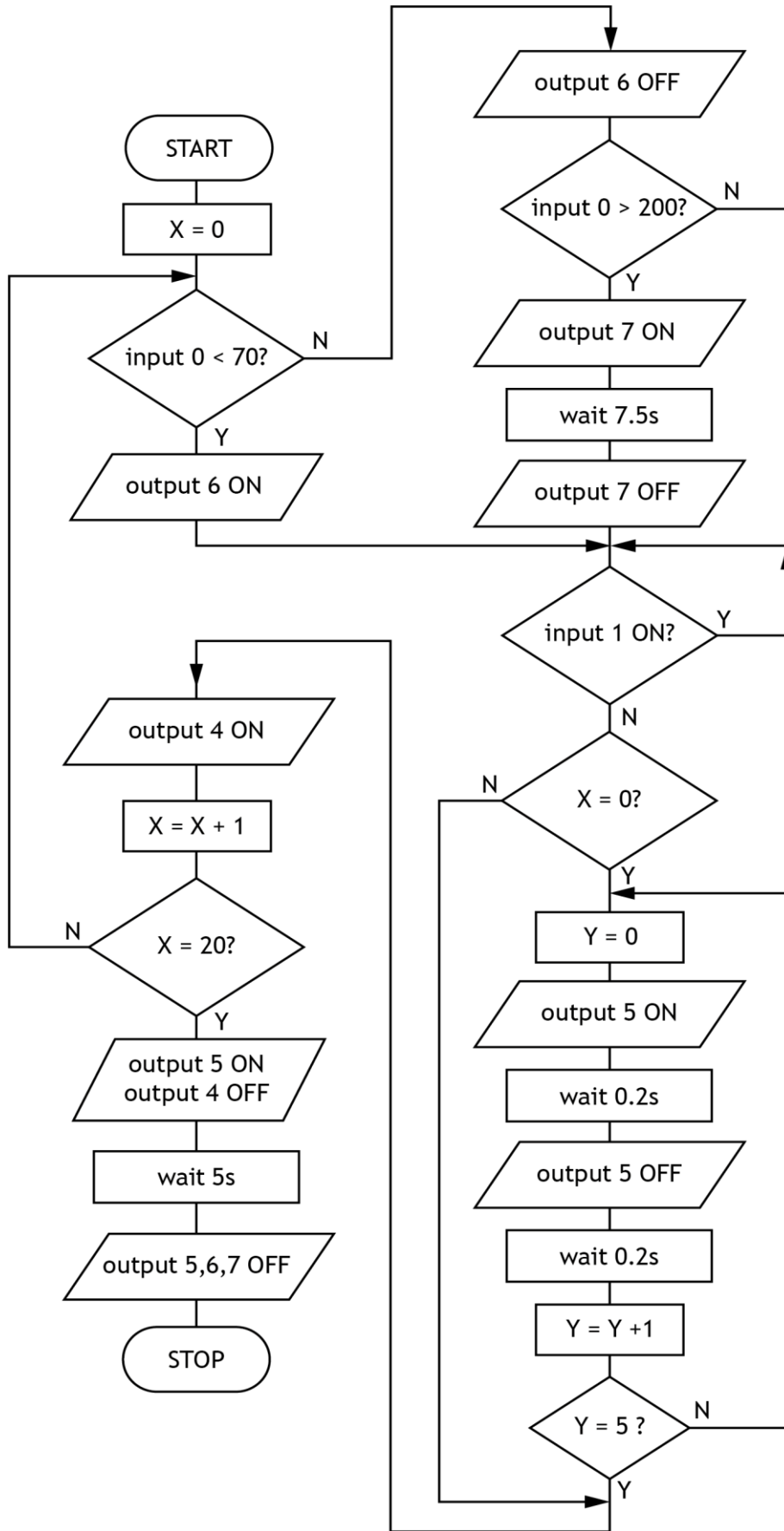

Task 5 – race control warning system (continued)

- 5b Simulate or construct the microcontroller system and the flowchart program **integrated together** as shown.

You must ensure that appropriate maximum ratings for components are used.

Produce a hard copy output of your simulation or construction. You must note the task number at the top of the page and your Scottish Candidate Number (SCN) at the bottom of the page. **(5 marks)**

The microcontroller system must work to the following specification:

- i When race conditions are safe and the race is able to begin, the race controller's start switch is closed to make the race control system operational.
- ii If the reading from the light sensor is under 70 at the start of a new lap, the track lighting turns on (and turns off again if the reading rises to 70 or more).
- iii If the reading from the light sensor is over 200 at the start of a new lap, a motor turns on for 7.5 seconds to raise mechanical blinds to prevent drivers being startled by bright sunlight at key points on the track.
- iv When the race starts, a red LED flashes five times before turning off, and a green LED turns on.
- v The race controller's start switch is checked once each lap, and if it is open the green LED turns off and the red LED turns on until this switch is closed again to resume racing.
- vi As the leading car completes each lap, a lap counter switch is pressed to record each lap up to twenty laps.
- vii When the leading car completes twenty laps, the green LED turns off, the red LED turns on for five seconds, before the whole system turns off.

It is known that there are errors in both the flowchart program and microcontroller circuit, meaning that specification points ii, iv, v and vi have not been met.

- 5c Test your simulation or construction against the specification points ii, iv, v and vi and complete the table provided in **worksheet 5c**.

You must write descriptions of the actual amendments that you made to enable the system to satisfy the specification.

Produce a hard copy output of your circuit following amendments after testing (clearly showing and annotating all amendments). You must note the task number at the top of the page and your Scottish Candidate Number (SCN) at the bottom of the page. **(4 marks)**

- 5d Evaluate and justify the performance of your amended microcontroller system from **task 5c** against the specification, by describing the overall effectiveness of your amended solution, and suggest one possible improvement to your amended microcontroller system. **(2 marks)**

[END OF ASSIGNMENT]

Copyright acknowledgements

Task 3 Image of racing car is taken from Pixabay.

Administrative information

Published: January 2025 (version 1.0)

History of changes

Version	Description of change	Date

Security and confidentiality

This document can be used by practitioners in SQA approved centres for the assessment of National Courses and not for any other purpose.

This document may only be downloaded from SQA's designated secure website by authorised personnel.

© Scottish Qualifications Authority 2025