

FOR OFFICIAL USE



--	--	--	--	--	--

National
Qualifications
2025

Mark

--

X823/76/01

Engineering Science

FRIDAY, 16 MAY

1:00 PM – 3:30 PM



* X 8 2 3 7 6 0 1 *

Fill in these boxes and read what is printed below.

Full name of centre

--

Town

--

Forename(s)

--

Surname

--

Number of seat

--

Date of birth

Day

--	--

Month

--	--

Year

--	--

Scottish candidate number

--	--	--	--	--	--	--	--	--	--

Total marks — 110

SECTION 1 — 20 marks

Attempt ALL questions.

SECTION 2 — 90 marks

Attempt ALL questions.

Show all working and units where appropriate.

You should refer to the Higher Engineering Science Data Booklet which you have been given. The number of significant figures expressed in a final answer should be equivalent to the least significant data value given in the question. Answers that have two more figures or one less figure than this will be accepted.

Write your answers clearly in the spaces provided in this booklet. Additional space for answers is provided at the end of this booklet. If you use this space you must clearly identify the question number you are attempting.

Use **blue** or **black** ink.

Before leaving the examination room you must give this booklet to the Invigilator; if you do not, you may lose all the marks for this paper.



* X 8 2 3 7 6 0 1 0 1 *

SECTION 1 — 20 marks

Attempt ALL questions

1. An electronic engineer has designed the following circuit as part of a remote-controlled product.

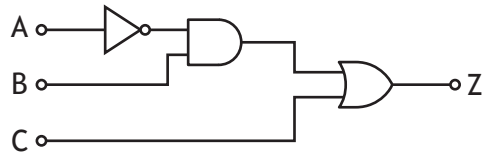

Draw a NAND equivalent for the circuit shown above. Simplify where appropriate.

4

A ○

B ○ ○ Z

C ○



2. An op-amp circuit is shown.

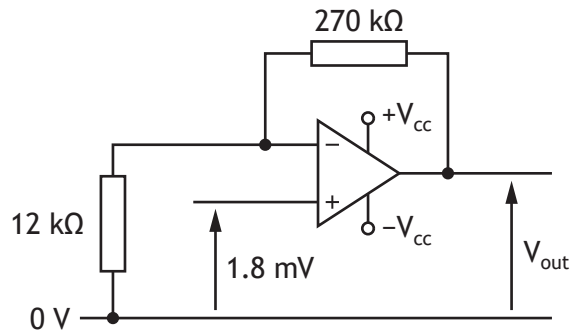

(a) Calculate the output voltage (V_{out}).

1

(b) Describe how the gain of the op-amp could be decreased.

1

An additional op-amp is required to combine V_{out} with two other voltage signals.

(c) State the op-amp configuration required to perform this task.

1

[Turn over



3. At a concert venue, frame structures are used to hold lighting in position.



A frame structure is shown below.

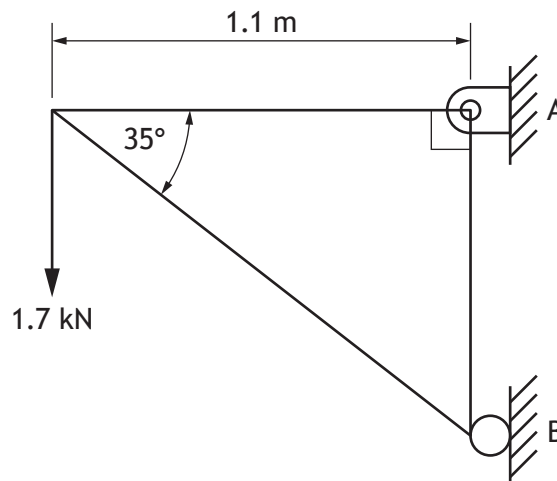

Calculate the magnitude and indicate the direction of the reaction at B.

4



4. The temperature inside an air fryer is set using a control panel.
 A programmable heating system monitors the temperature inside the air fryer and maintains a set temperature.



Complete the control diagram below for the programmable heating system of the air fryer.

3

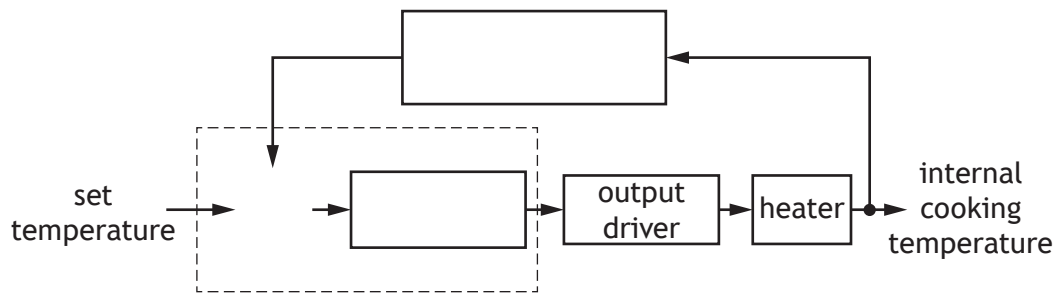

[Turn over



5. A concurrent force system is shown.

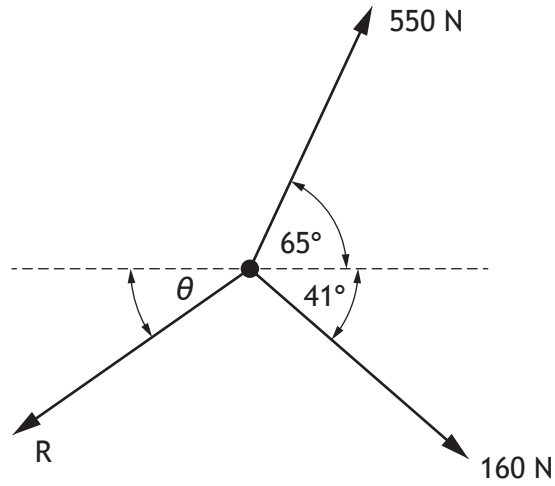

Calculate the magnitude of the force, R , and the angle, θ , required to maintain equilibrium.

4



6. A specially engineered car is used in the production of a film. It can be adjusted so that many features such as its length and width can match those of other cars (eg classic or rare cars).

After filming it in a scene, a special effects team superimpose the bodywork and the look of the car that the filmmaker wants to see.



original image

superimposed image

Describe two impacts that this technology would have on a company making a film. 2

Impact 1 _____

Impact 2 _____

[Turn over



SECTION 2 — 90 marks

Attempt ALL questions

7. A team of engineers is asked to design a viewing platform for a zoo.



Tensile test results for three materials considered for use in the viewing platform are shown in the stress-strain graph below.

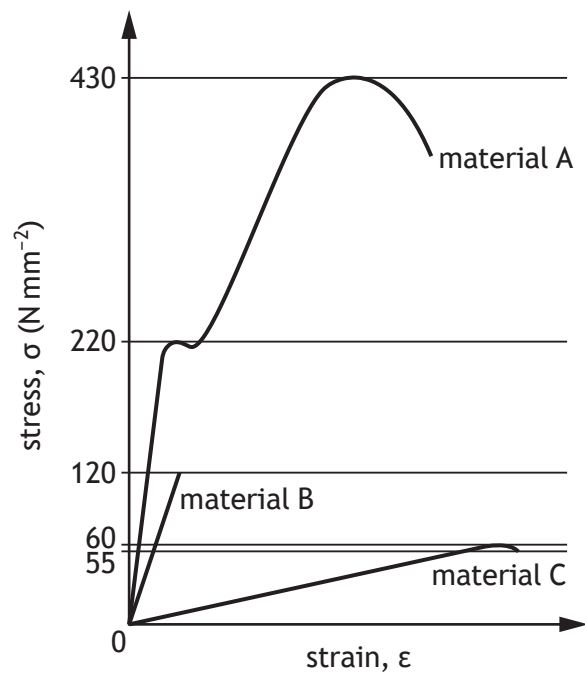

* X 8 2 3 7 6 0 1 0 8 *

7. (continued)

- (a) Describe, with reference to the stress-strain graph, shown opposite, three different properties of material C in relation to material A or material B.

3

Property 1 _____

Property 2 _____

Property 3 _____

[Turn over



* X 8 2 3 7 6 0 1 0 9 *

7. (continued)

A partially completed free-body diagram of the design for the viewing platform is shown.

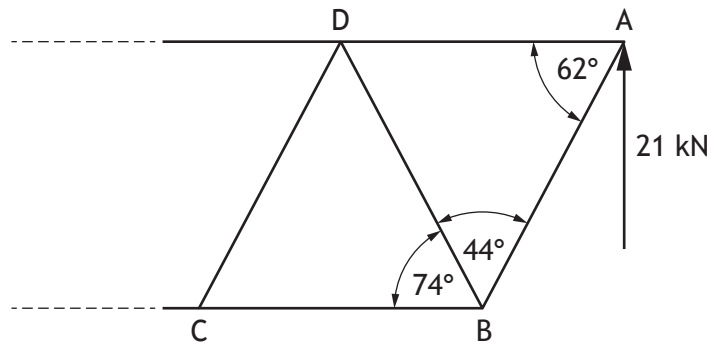

- (b) Calculate, using nodal analysis, the magnitude and nature of the forces in members AB, AD, BD and BC.

Show all working and final units on the page opposite.

Complete the table below.

7

Member	Magnitude	Nature
AB		tie
AD		strut
BD		
BC		



7. (b) (continued)

Space for calculations

node A

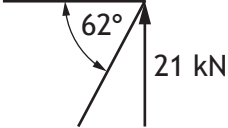

node B

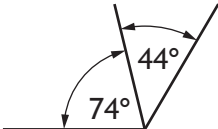

[Turn over



7. (continued)

(c) A number of engineers are involved in the development phase of the viewing platform project.

(i) Describe two skills a structural engineer would use when developing the structure for the viewing platform.

2

Skill 1 _____

Skill 2 _____

(ii) Describe two roles of an environmental engineer during the development phase of the project.

2

Role 1 _____

Role 2 _____



* X 8 2 3 7 6 0 1 1 2 *

[Turn over for next question

DO NOT WRITE ON THIS PAGE



* X 8 2 3 7 6 0 1 1 3 *

8. A prototype of an electrically-powered car is developed and tested by a team of engineers. The car is powered by four motors that each supply 62 kW.



Mike Mareen/Shutterstock.com

- (a) Calculate the rotational speed of one motor if it produces 230 Nm of torque.

1



8. (continued)

When all four of the 62 kW motors are operating at full power the car is 0.81 (81%) efficient. The car's battery stores 363 MJ when fully charged.

- (b) Calculate how much time the car is able to run at full power before the battery is out of charge.

2

[Turn over



8. (continued)

Improving efficiency is a key task for the engineers who design the car.

- (c) Describe one economic and one social impact of improving the efficiency of the car.

2

Economic _____

Social _____

When the car is slowed, an energy recovery system transforms its kinetic energy back into electrical energy to recharge the battery.

During testing, the combined mass of the car and passengers is 2200 kg and the energy recovery system is 0.68 (68%) efficient.

- (d) Calculate the energy recovered if the car's velocity changes from 31 ms^{-1} to 12 ms^{-1} .

3



8. (continued)

Bearings are required on the shafts of each motor to ensure that they are supported and can transfer power to the wheels.

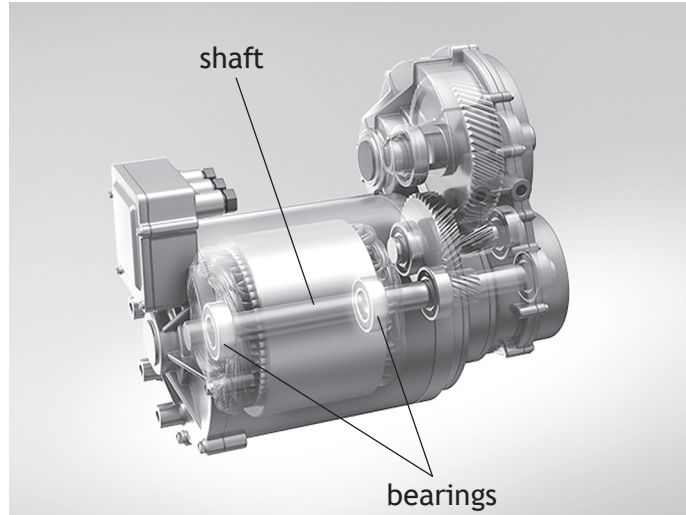

- (e) Explain, giving two examples, why friction needs to be minimised in the bearings.

2

Example 1 _____

Example 2 _____

[Turn over



8. (continued)

A test circuit designed to control the brightness of the dashboard display in the car is shown below. Signals from a microcontroller are sent to the op-amp circuit which outputs an analogue voltage to the display.

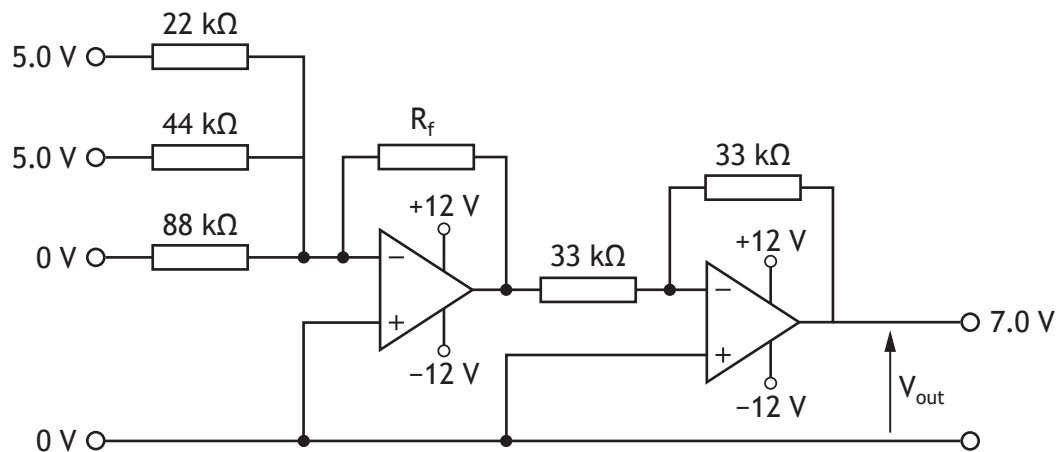

(f) Calculate the value of the feedback resistor, R_f , when V_{out} is 7.0 V.

3



[Turn over for next question

DO NOT WRITE ON THIS PAGE



* X 8 2 3 7 6 0 1 1 9 *

9. A vertical farm grows vegetables in a controlled indoor environment. It has an electronic monitoring system to keep the temperature between 18 °C and 22 °C.



A heat sensor monitors the temperature of the indoor environment and it produces an output voltage, V_{heat} .

A test circuit to ensure correct operation is shown.

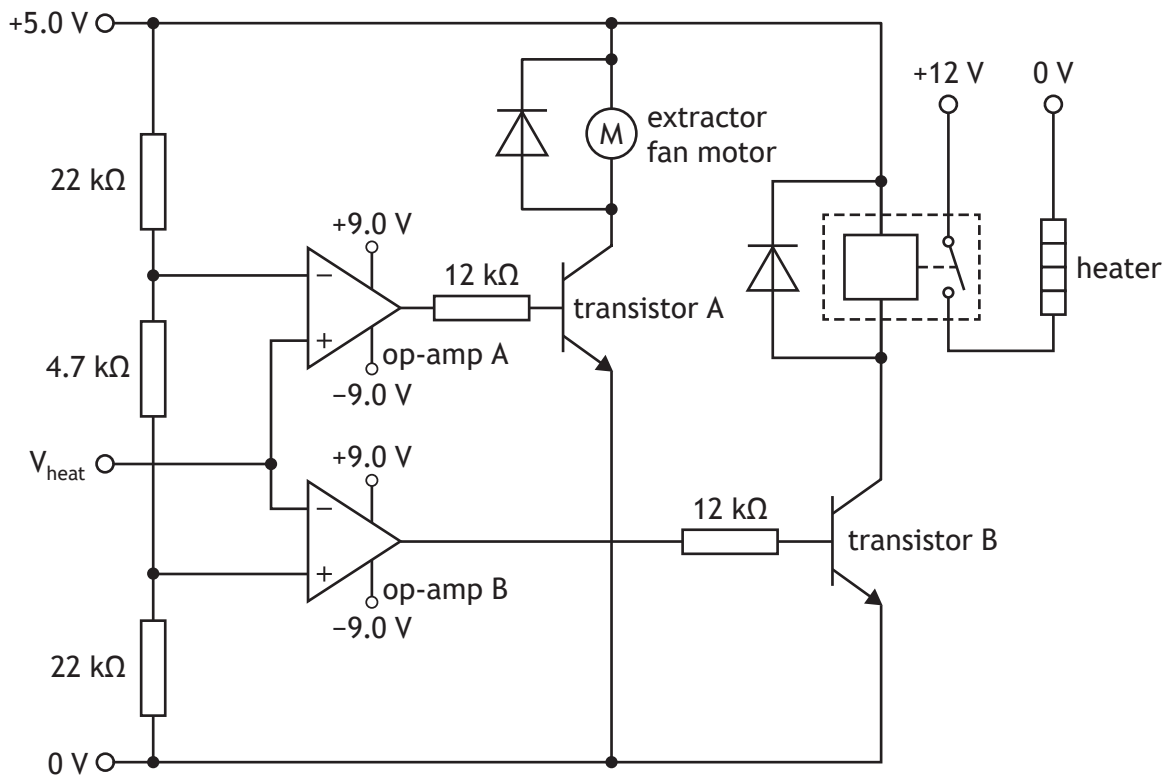

9. (continued)

The voltage divider that sets the reference values for the op-amps is shown in isolation below.

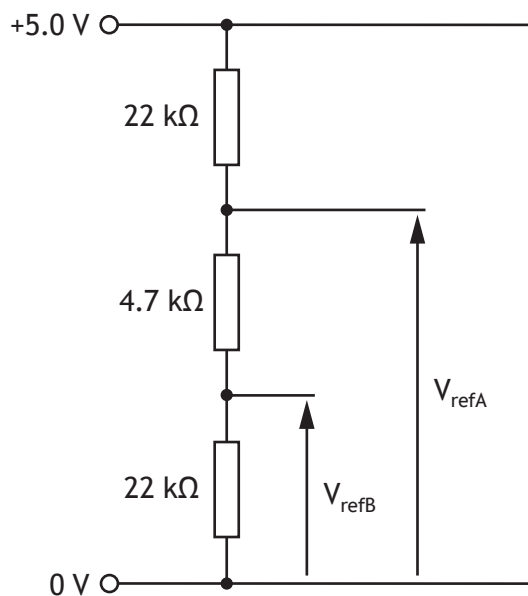

(a) Calculate the reference voltage V_{refA} .

2

[Turn over



9. (continued)

Another section of the circuit is shown.

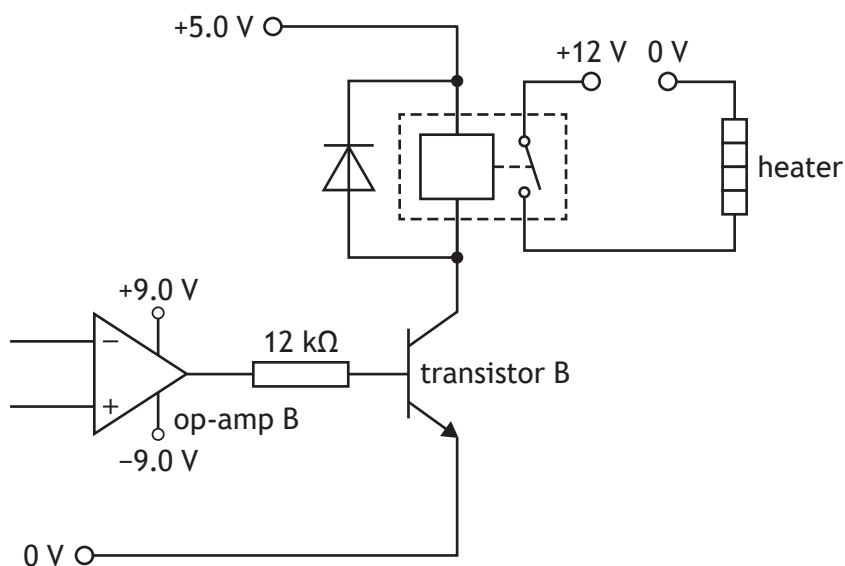

- (b) (i) Calculate the base current for transistor B when op-amp B is saturated positive. (Assume V_{BE} is 0.70 V and that the op-amp saturates at 82% of its supply voltage).

3

Transistor B has a gain, h_{FE} , of 230 for a base current of 610 μA .

- (ii) Calculate the collector current when op-amp B is saturated.

1



[Turn over for next question

DO NOT WRITE ON THIS PAGE



* X 8 2 3 7 6 0 1 2 3 *

9. (continued)

MARKS DO NOT WRITE IN THIS MARGIN

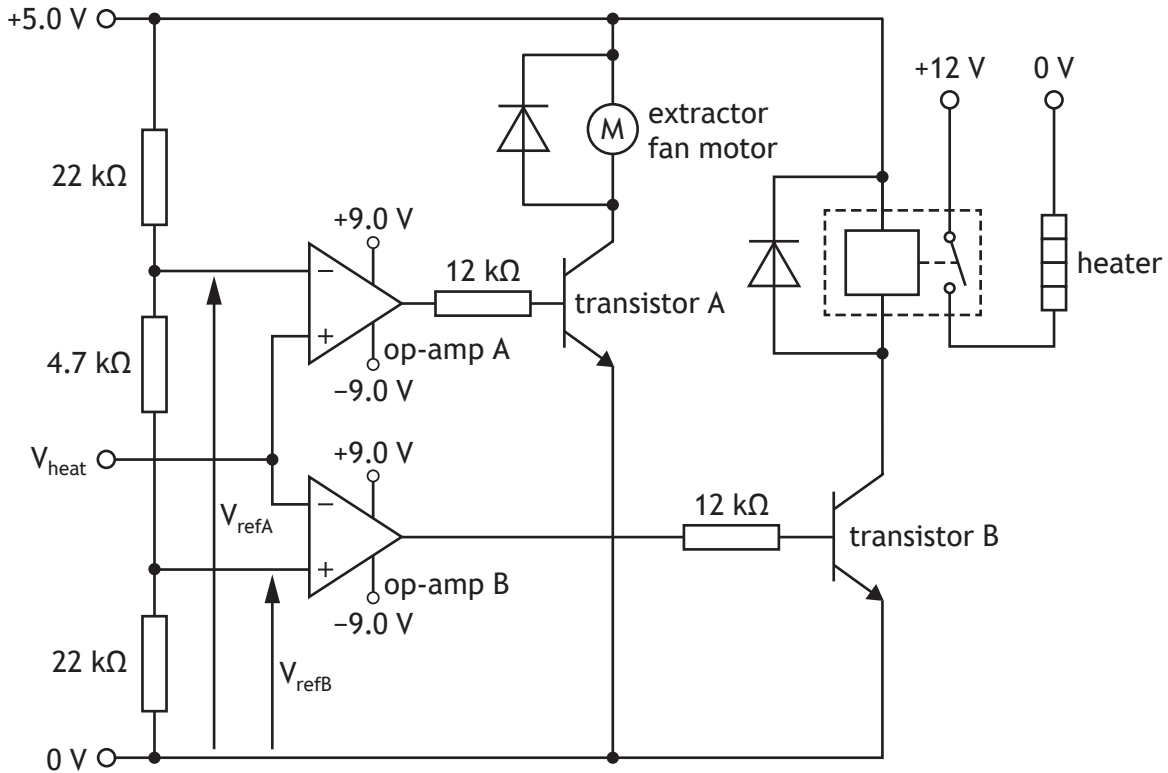

(c) Describe, with reference to the op-amps and transistors in the circuit above, what happens when V_{heat} rises from 0 V to 5.0 V.

6

When V_{heat} is less than V_{refB} _____

When V_{heat} is between V_{refB} and V_{refA} _____

When V_{heat} is greater than V_{refA} _____



* X 8 2 3 7 6 0 1 2 4 *

9. (continued)

An electronic engineer has been asked to improve the system.

It must be adapted to allow users to easily adjust the temperatures at which the heater or fan switch on and off.

- (d) Describe how the control circuit could be adapted and give a justification for your suggestion.

2

Adaptation _____

Justification _____

[Turn over



* X 8 2 3 7 6 0 1 2 5 *

10. A media company is producing an action film.

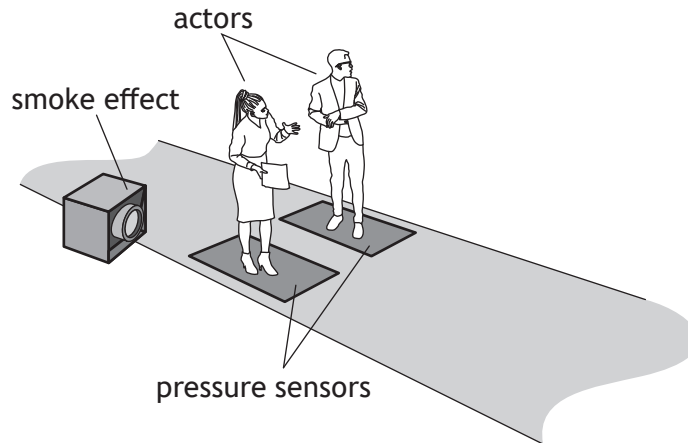

During the production of the film, a smoke effect is to be used. The system involved uses a safety switch (A), two pressure sensors (B and C) and a test switch (D). The smoke effect must only be activated when the following conditions are met:

1. The smoke effect (Z) can only activate if the safety switch is high.
2. The smoke effect will not activate if either pressure sensor is high.
3. The smoke effect will activate if a test switch is high.

(a) Complete a Boolean equation to describe when the smoke effect is activated. 4

Z = _____



[Turn over for next question

DO NOT WRITE ON THIS PAGE



* X 8 2 3 7 6 0 1 2 7 *

10. (continued)

In another scene, when an actor leaves a pressure pad an automated camera must move to film them.

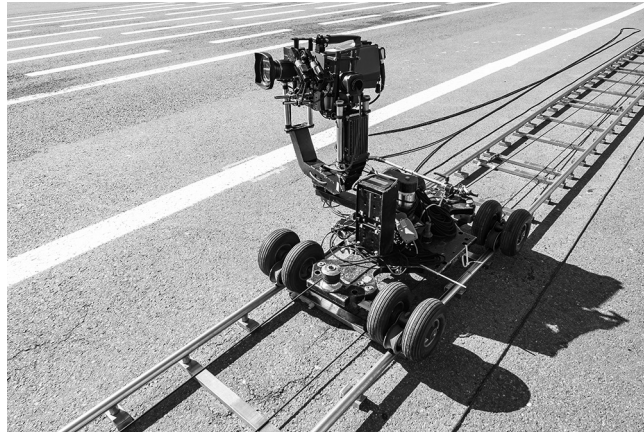

The carriage that moves the camera is powered by a motor. The motor's speed is controlled using pulse-width modulation (PWM) to match the speed of the actor. A speed sensor monitors the speed of the actor.

The PWM signal will have 255 ms pulses.

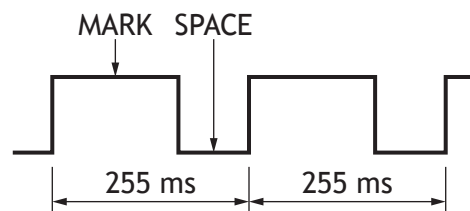

The control sequence for the motor has the following steps:

- The motor will only activate when a safety switch has been pressed and a pressure pad has been released.
- Before the motor starts, a reading is taken from a speed sensor and its value stored in a variable X. (The reading from the speed sensor will be in the range 0–255, where 255 refers to the maximum speed).
- The mark time for PWM must be the value in X.
- The space time will be the difference between the value in X and 255.
- The motor must be switched on and off for the times specified by mark and space.
- The reading of the speed sensor and the production of the PWM signal repeats until a limit switch is pressed or the safety switch is released.
- The system must reset to the start.

Input connections	Pin	Output connections
	7	motor
limit switch (1 = pressed)	3	
pressure sensor (0 = released)	2	
speed sensor (analogue)	1	
safety switch (1 = pressed)	0	



10. (continued)

- (b) Complete, with reference to the control sequence shown opposite, the flowchart for the operation of the motor.

9

start



11. At a porridge factory, containers are filled from an overhead oat hopper as shown below.

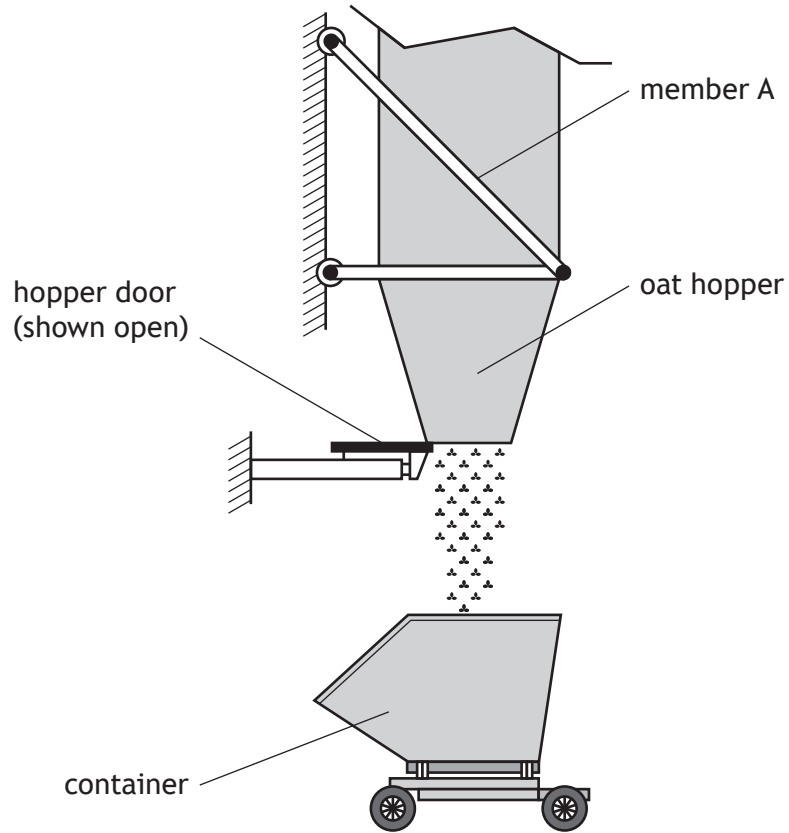

The oat hopper is supported by a frame structure.

Member A within the structure is a solid round aluminium alloy bar of diameter 22 mm. The maximum safe working load in member A is 42 kN.



11. (continued)

(a) Calculate the factor of safety of member A.

4

[Turn over



11. (continued)

A new design uses the following cross-section of mild steel for member A.

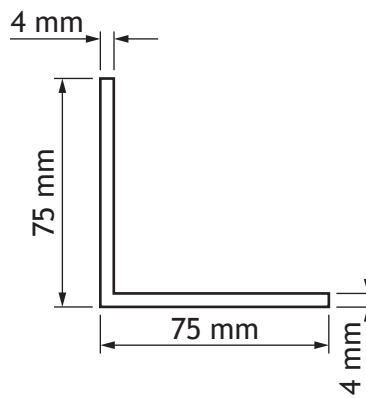

Member A has a length of 2.7 m.

- (b) (i) Calculate the change in length of member A due to the 42 kN load.

5



11. (b) (continued)

A factor of safety of 15 is applied to the new design. However a factor of safety of 2.5 was advised by the structural engineer.

(ii) State two reasons why the structural engineer gave this advice.

2

Reason 1 _____

Reason 2 _____

[Turn over



* X 8 2 3 7 6 0 1 3 3 *

11. (continued)

The hopper door is re-designed so that a cylinder closes a hinged door. When the oat hopper is partially loaded, the door loading is shown as in the diagram below.

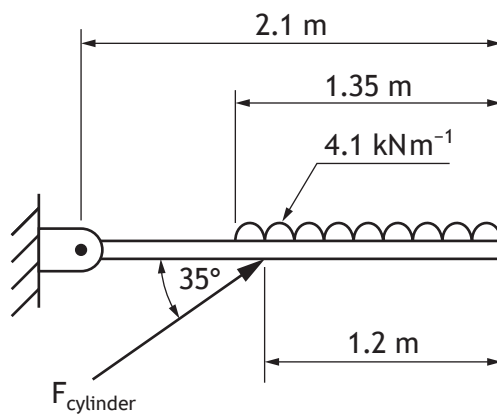

(c) Calculate the magnitude of F_{cylinder} .

3



11. (continued)

After testing, the pressure in the cylinder is changed so that the magnitude of F_{cylinder} is 18 kN and the universal distributed load is 4.8 kNm^{-1} .

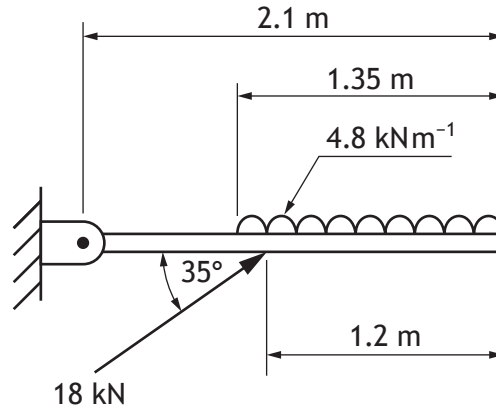

(d) Calculate the magnitude and direction of the reaction at the hinge.

4



12. A pneumatic system will be used in a manufacturing process for holding material in place and then moving it along a production line. The pneumatic circuit diagram is shown below.

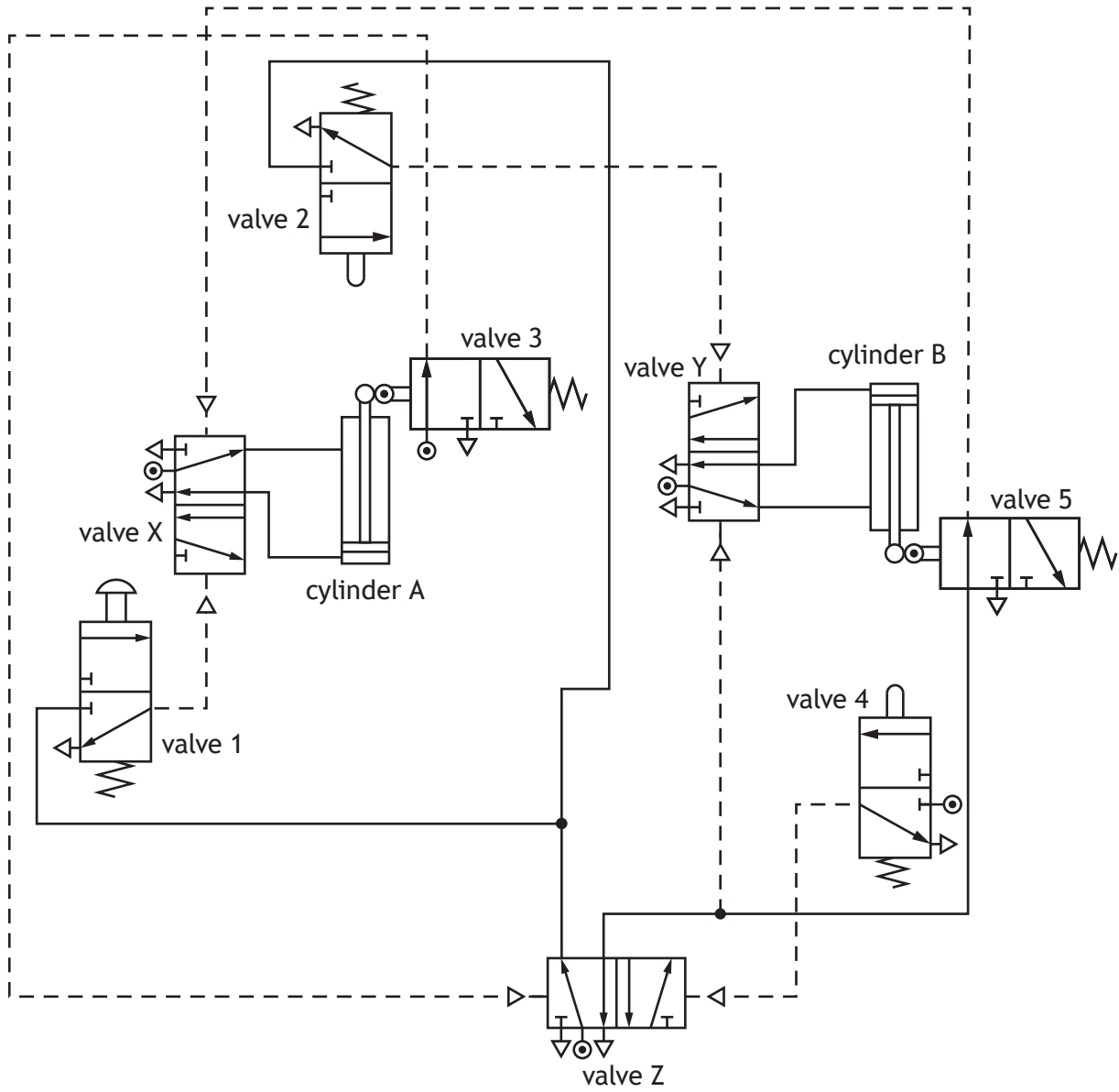

12. (continued)

The push button actuator is to be replaced by a solenoid to allow the pneumatic circuit to be controlled electronically. A diagram of the control circuit for the solenoid is shown.

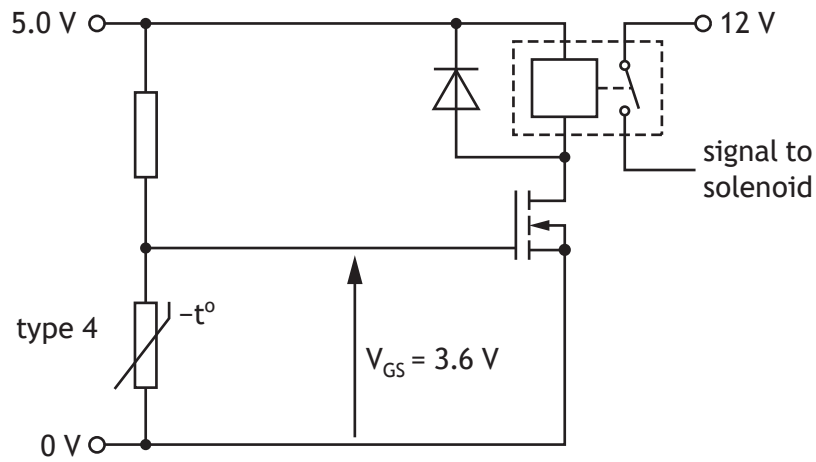

The MOSFET switches on when the gate-source voltage, V_{GS} , reaches 3.6 V. This happens when the thermistor reaches 25 °C.

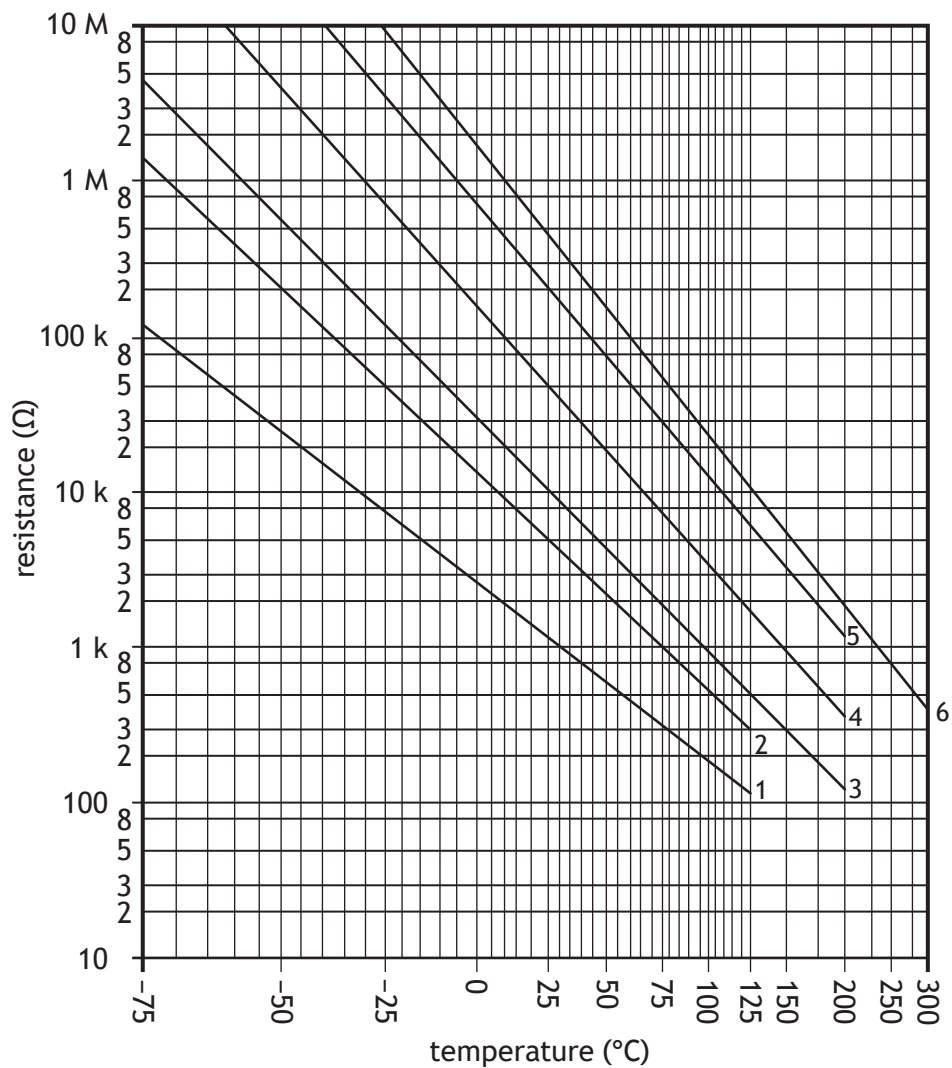

12. (continued)

(b) Describe one advantage of using a MOSFET rather than a bipolar junction transistor (BJT).

1

(c) Describe the meaning of the term 'threshold voltage' as applied to MOSFETs.

1

(d) Calculate, with reference to the graph shown opposite, the resistance of the fixed resistor required to produce a gate-source voltage, V_{GS} , of 3.6 V.

3



12. (continued)

A different stage of the manufacturing process requires a drive system. Part of the design involves rotary motion, from a motor, transforming into linear motion.

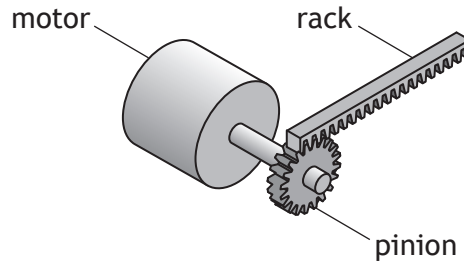

The pinion has 36 teeth and the rack has 120 teeth per metre. The rotational speed of the motor shaft is 75 revs min^{-1} .

- (e) Calculate the linear speed, in metres per second, at which the rack will move.

3



12. (continued)

Part of the circuit controlling the motor is shown below.

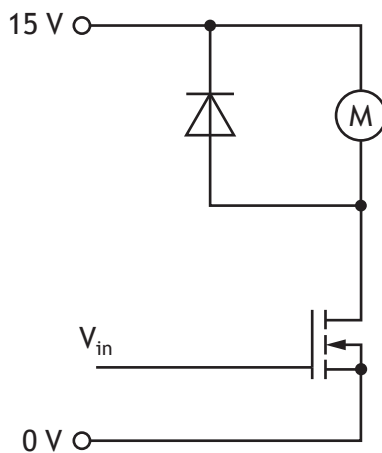

The motor has a rating of 15 V and 5.8 W.

When the motor is switched on the MOSFET has a drain-source resistance of 1.8Ω .

(f) Calculate the MOSFET drain-source current.

3

[END OF QUESTION PAPER]



MARKS DO NOT
WRITE IN
THIS
MARGIN

ADDITIONAL SPACE FOR ANSWERS



* X 8 2 3 7 6 0 1 4 2 *

MARKS DO NOT
WRITE IN
THIS
MARGIN

ADDITIONAL SPACE FOR ANSWERS



* X 8 2 3 7 6 0 1 4 3 *

[BLANK PAGE]

DO NOT WRITE ON THIS PAGE

Acknowledgement of copyright

Question 3 dwphotos/shutterstock.com

Question 4 ApoGapo/shutterstock.com

Question 6 Images are taken from <https://www.roadandtrack.com/car-culture/videos/a29712/the-mill-blackbird-carcommercials/>

SQA has made every effort to trace the owners of copyright of this item and seek permissions. We are happy to discuss permission requirements and incorporate any missing acknowledgement. Please contact question.papers@sqa.org.uk.

Question 7 LyubovKro/shutterstock.com

Question 8 Mike Mareen/shutterstock.com

Question 8 (e) Image is taken from <https://www.nsk.com/eu-en/company/news/2020/nsk-develops-ultra-high-speed-ballbearings-for-ev-motors/>

SQA has made every effort to trace the owners of copyright of this item and seek permissions. We are happy to discuss permission requirements and incorporate any missing acknowledgement. Please contact question.papers@sqa.org.uk.

Question 9 Lano Lan/shutterstock.com

Question 10 FOTOGRIN/shutterstock.com



* X 8 2 3 7 6 0 1 4 4 *