

FOR OFFICIAL USE



National  
Qualifications  
2015

Mark

**X735/76/01**

**Graphic Communication**

THURSDAY, 30 APRIL

1:00 PM – 3:00 PM



\* X 7 3 5 7 6 0 1 \*

Fill in these boxes and read what is printed below.

Full name of centre

Town

Forename(s)

Surname

Number of seat

Date of birth

Day

Month

Year

Scottish candidate number

**Total marks — 70**

Attempt ALL questions.

All dimensions are in mm.

All technical sketches and drawings use third angle projection.

You may use rulers, compasses or trammels for measuring.

In all questions you may use sketches and annotations to support your answer if you wish.

Write your answers clearly in the spaces provided in this booklet. Additional space for answers is provided at the end of this booklet. If you use this space you must clearly identify the question number you are attempting.

Use **blue** or **black** ink.

Before leaving the examination room you must give this booklet to the Invigilator; if you do not, you may lose all the marks for this paper.



\* X 7 3 5 7 6 0 1 0 1 \*

[BLANK PAGE]

DO NOT WRITE ON THIS PAGE



\* X 7 3 5 7 6 0 1 0 2 \*

Total marks — 70  
Attempt ALL questions

1. A CAD Technician created a 3D model of the fire extinguisher, shown below.

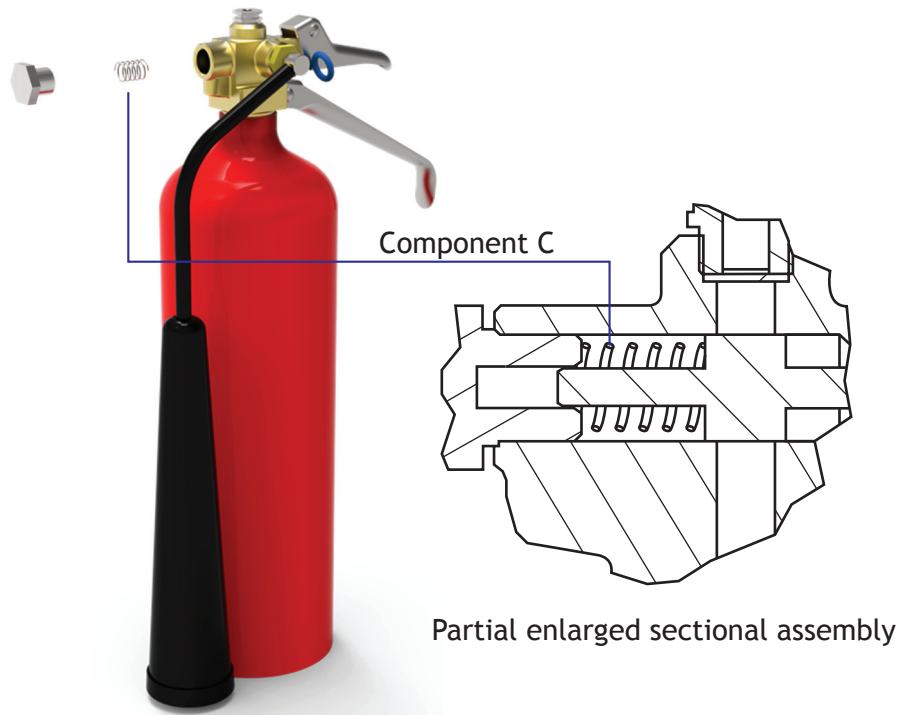

- (a) Component C was modelled using 3D CAD.

Describe the 3D CAD modelling technique used to create component C.  
You may use sketches to illustrate your answer.

2



\* X 7 3 5 7 6 0 1 0 3 \*

1. (continued)

MARKS

DO NOT WRITE IN THIS MARGIN

A drawing of the pipe and nozzle sub-assembly is shown below. This was used by the CAD Technician to create models of the individual components.

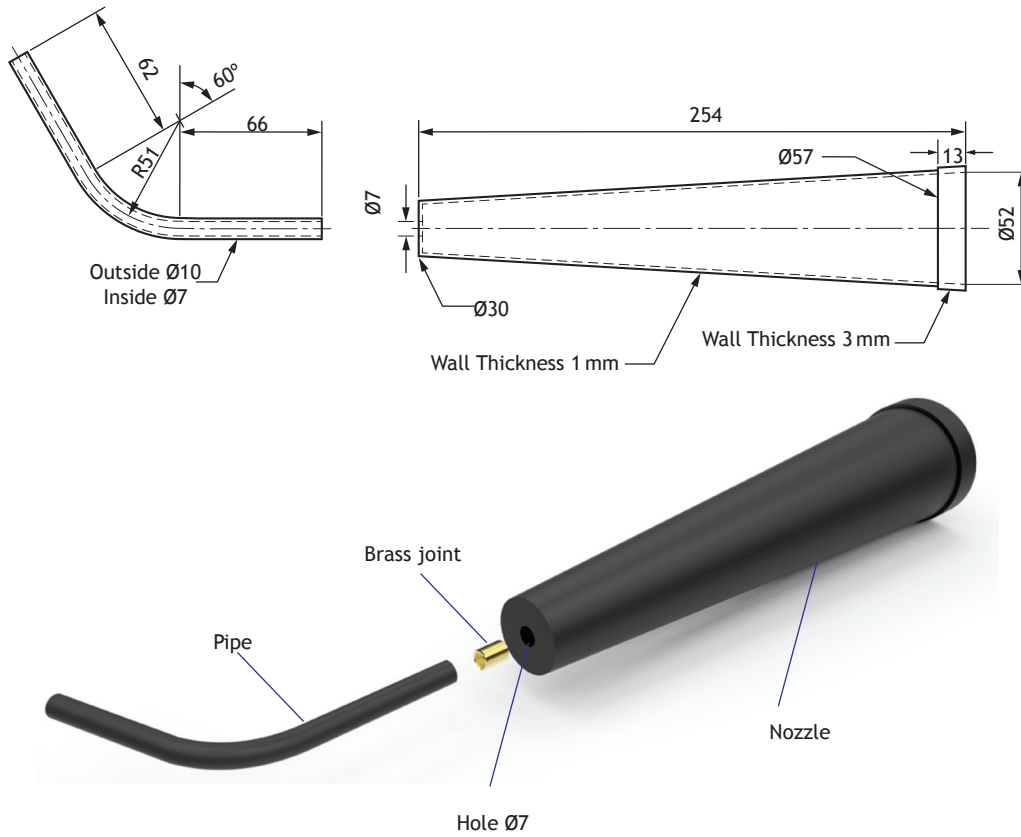

(b) Describe the 3D CAD modelling techniques used to create the pipe component. Refer to the dimensions given in the drawing. 3



MARKS

DO NOT  
WRITE IN  
THIS  
MARGIN

1. (continued)

- (c) Describe the 3D CAD modelling techniques used to create the **nozzle** component. Refer to the dimensions given in the drawing.

6

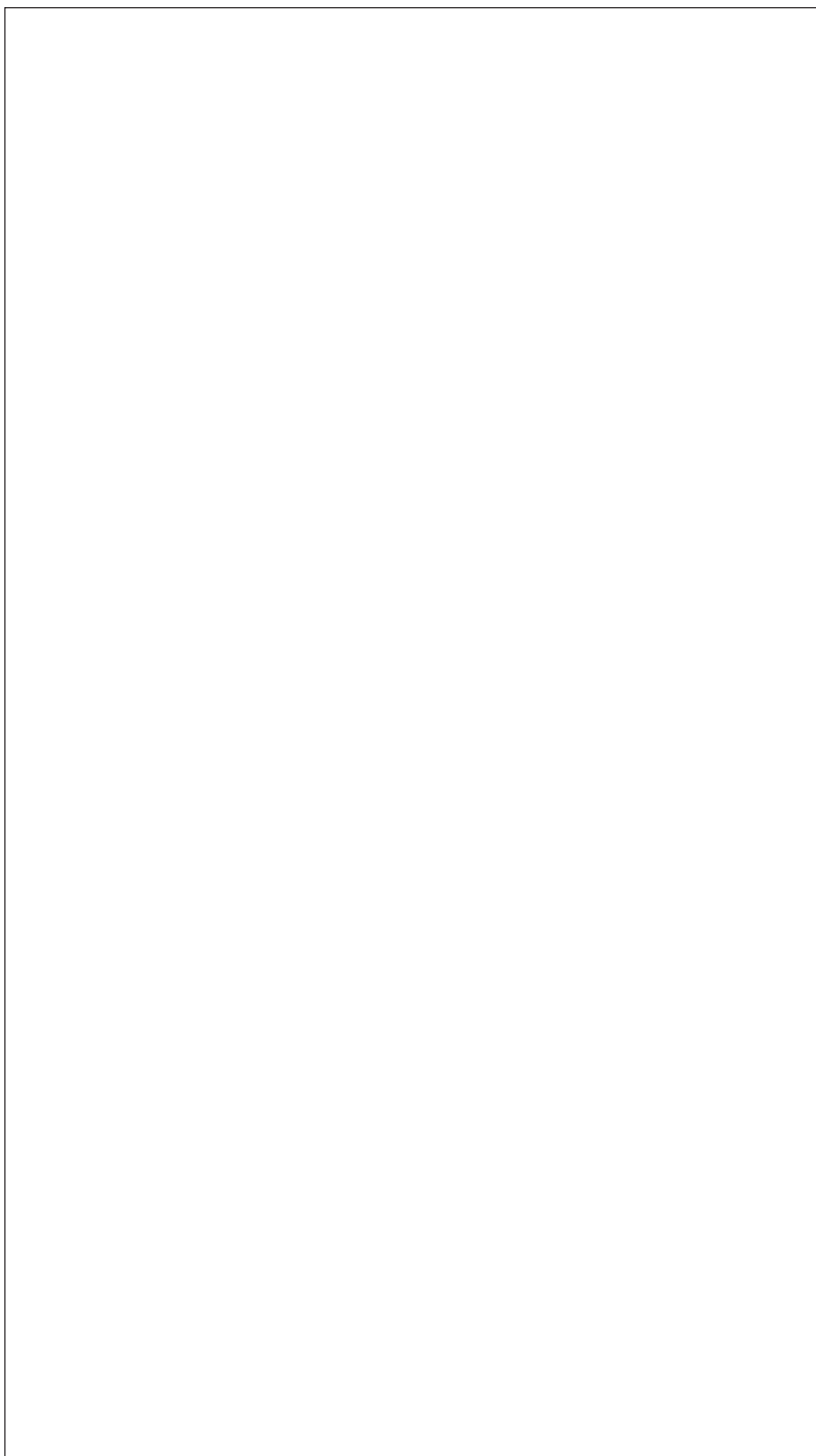

\* X 7 3 5 7 6 0 1 0 5 \*

1. (continued)

The manufacturer of the fire extinguisher would like to provide a simple wall bracket to hold their product.

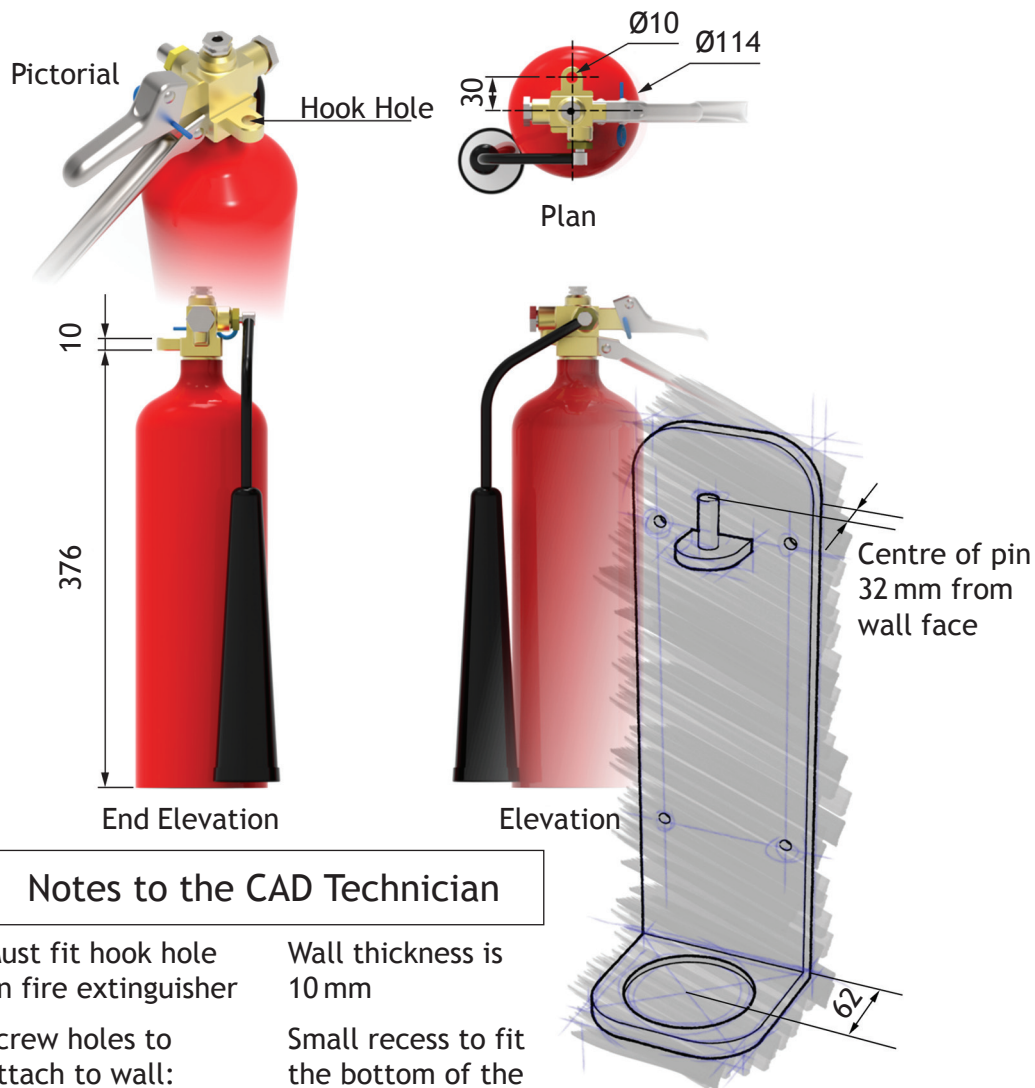

**MARKS**

DO NOT  
WRITE IN  
THIS  
MARGIN

1. (continued)

- (d) Describe the 3D CAD modelling techniques used to create the wall bracket.

Use measurements from the rendered orthographic and the “Notes to the CAD Technician”. You may use sketches to explain your answer.

7



\* X 7 3 5 7 6 0 1 0 7 \*

2. Glasgow Riverside Museum opened in 2011. As with any other building built in this country the architecture firm was required to submit a number of different drawings to the local authority to gain planning permission. During this process the architects also produced a number of other graphics for different purposes.



Figure 1

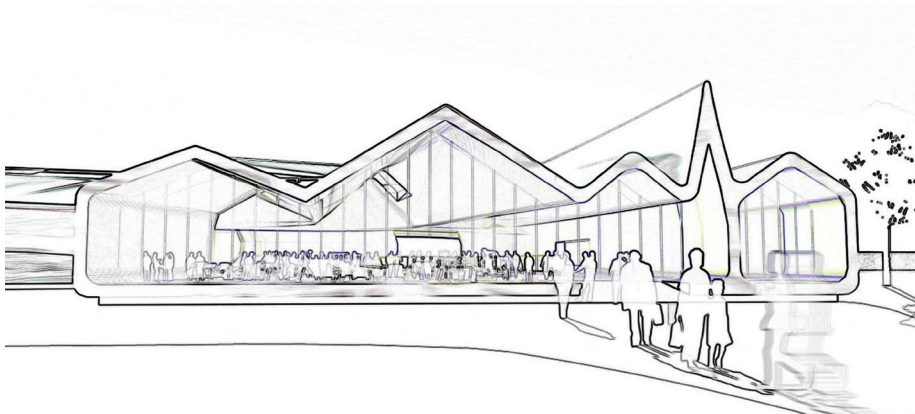

Figure 2



Figure 3



2. (continued)

- (a) Explain, with reference to the 3P's, the purpose of each of the graphics shown in Figures 1, 2 and 3.

3

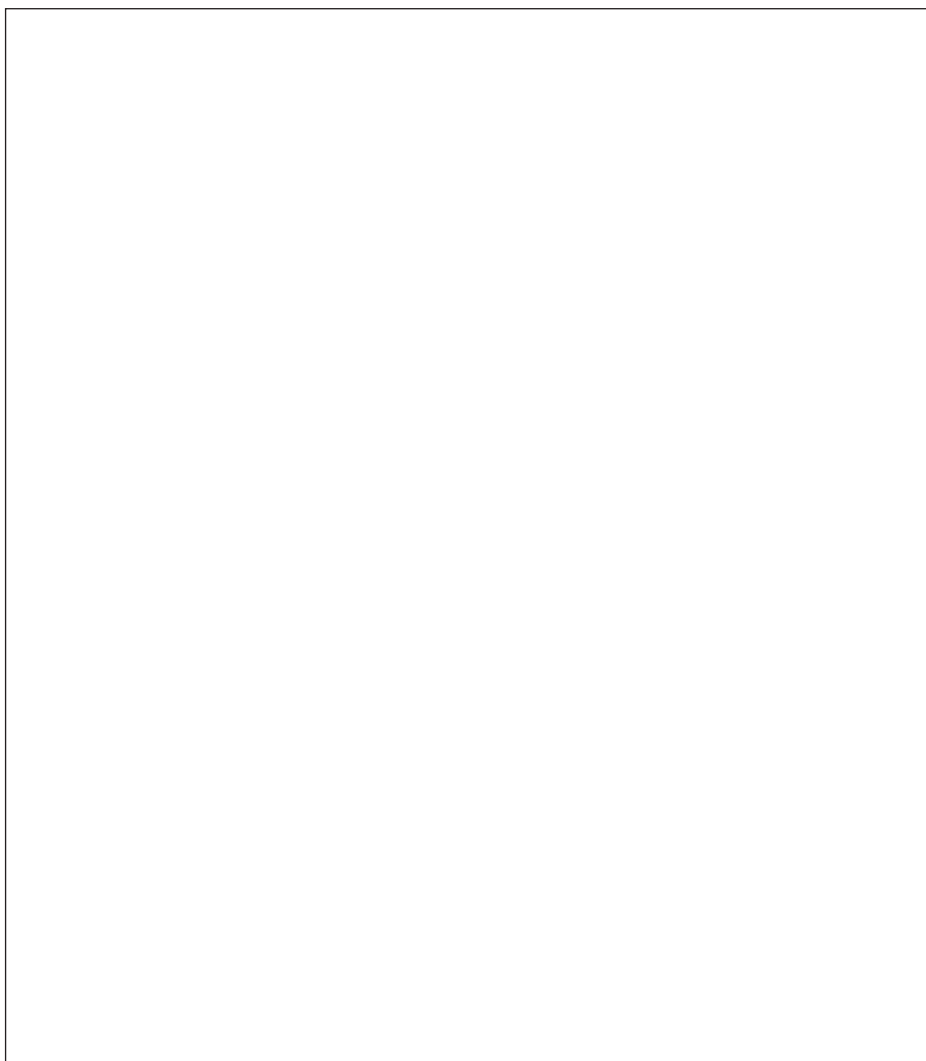

The scales commonly used for figure 3 are 1:50 or 1:100.

- (b) State **two** factors that influence the choice of scale in this type of graphic.

2

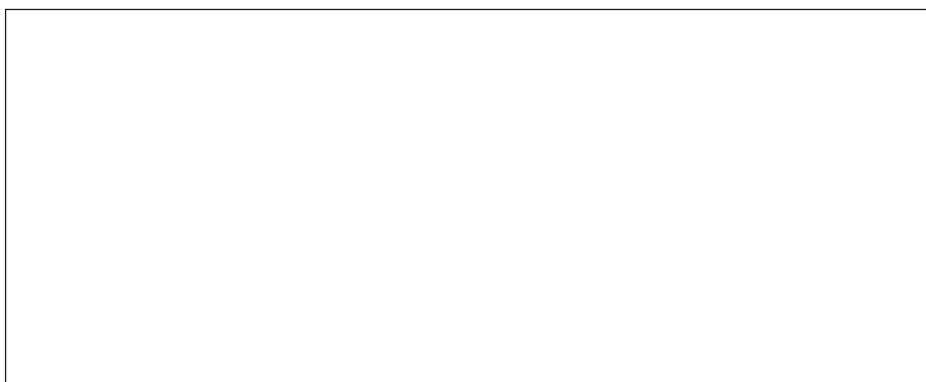

2. (continued)

Sectional views are commonly used in the construction industry. Cross-hatching is a feature found in sectional construction views.

- (c) Describe the benefits of applying cross-hatching to a sectional construction drawing.

2

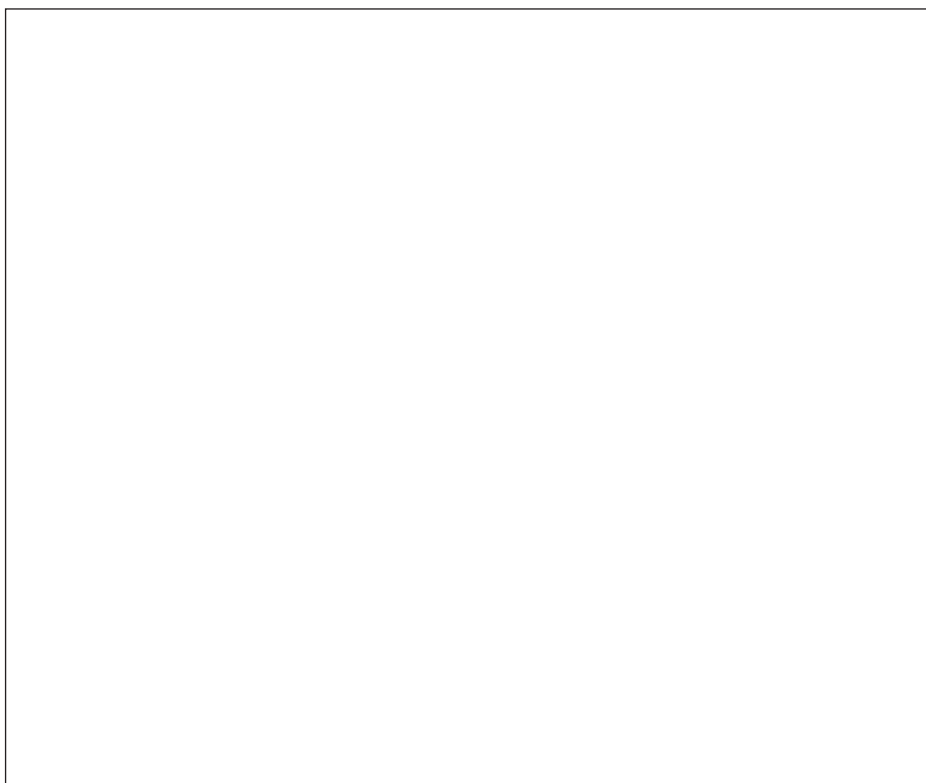

The standardised construction drawing symbols and conventions shown below are commonly found in many construction drawings.

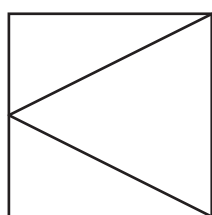

Figure 4

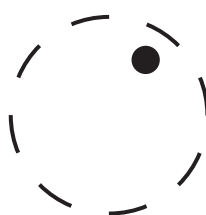

Figure 5



Figure 6

- (d) Identify each of the symbols/conventions.

3

Figure 4 \_\_\_\_\_

Figure 5 \_\_\_\_\_

Figure 6 \_\_\_\_\_



3. With the rise in popularity of tablets and smartphones, publishers now produce most of their publications in both hardcopy and digital versions.



(a) Describe the advantages to the consumer that the digital format offers over the hardcopy.

2

(b) Describe why companies advertising within the publication may prefer the digital format to the hardcopy format.

2



MARKS

DO NOT  
WRITE IN  
THIS  
MARGIN

3. (continued)

Some publishers are considering moving completely to a digital based distribution of their publications.

(c) **Explain** the disadvantages in the distribution of the digital version over the hardcopy version.

4



\* X 7 3 5 7 6 0 1 1 2 \*

MARKS

DO NOT  
WRITE IN  
THIS  
MARGIN

[Turn over for Question 4 on *page fourteen*

DO NOT WRITE ON THIS PAGE



\* X 7 3 5 7 6 0 1 1 3 \*

4. A furniture designer has produced a 3D CAD illustration of a new table design. The furniture designer needs to prepare the design for manufacture.

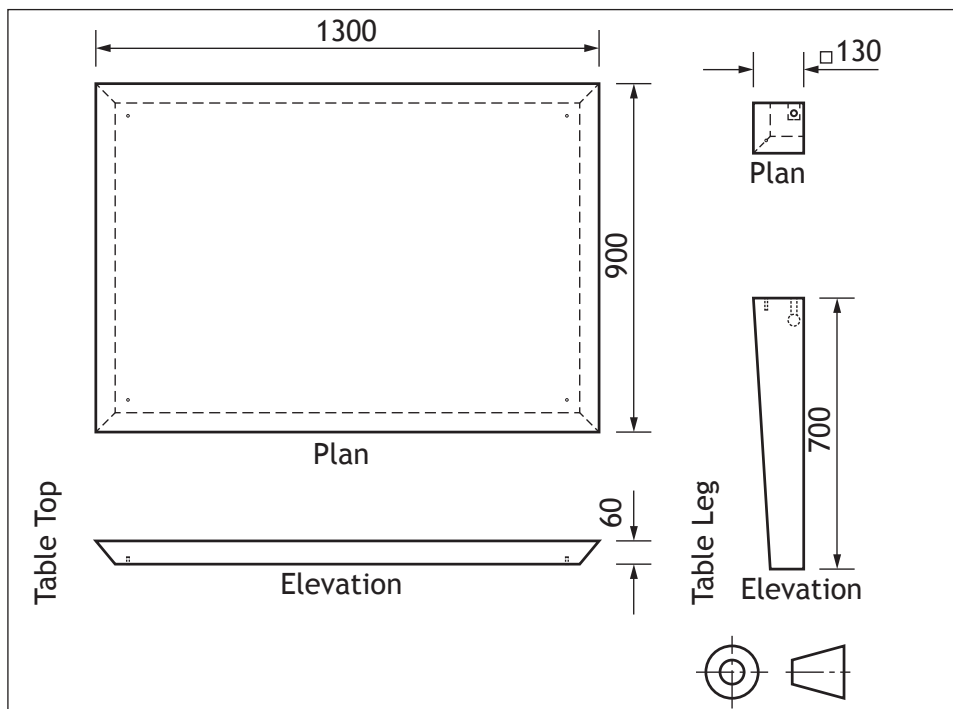

Figure 1

The component drawing of the table top and legs, in Figure 1, are drawn to a scale.

- (a) Measure and calculate the scale used for Figure 1.

1



\* X 7 3 5 7 6 0 1 1 4 \*

4. (continued)

The manufacturer has recommended that tolerances be applied to components of the table. They have suggested the following tolerances;

Length of table leg +1.5mm and -0.5mm

Thickness of table top +2.5 mm and -1.5mm

- (b) Calculate the maximum and minimum allowable heights of the fully assembled table after applying the tolerances. 2

Maximum height \_\_\_\_\_ mm Minimum height \_\_\_\_\_ mm

- (c) Apply the dimensional tolerances to the views below using the correct British Standard conventions. 2

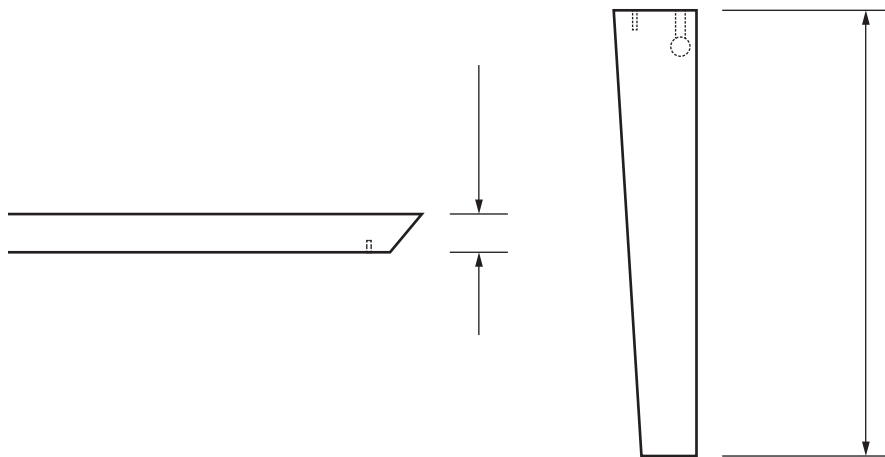

[Turn over



\* X 7 3 5 7 6 0 1 1 5 \*

4. (continued)

Knock-down fittings are commonly used in flat-pack furniture design as they make furniture easy to assemble; they require no specialist skills and are easily mass produced. Shown below are the component drawings for two of the most common knock-down fittings used by the retailer (figures 2 and 3) and extracts from the draft assembly instructions (figures 4 and 5).

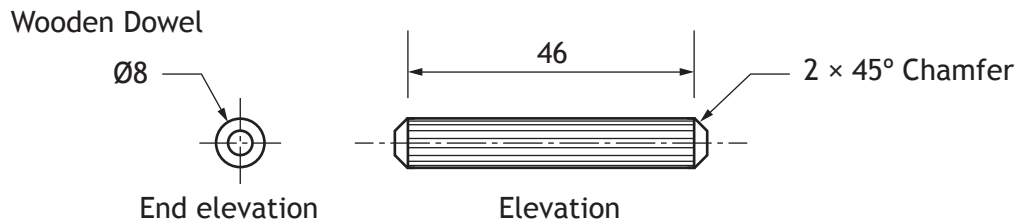

Figure 2  
(not to scale)

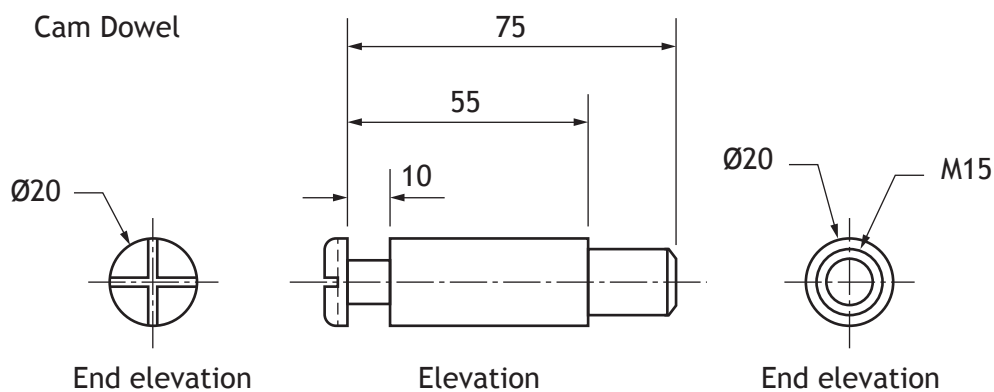

Figure 3  
(not to scale)



Figure 4

Exploded view of assembly method

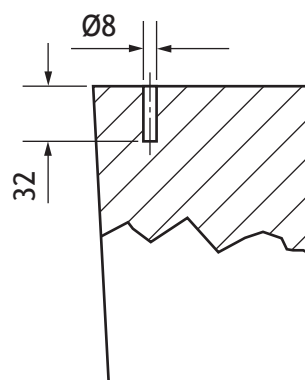

Figure 5

Enlarged technical drawing of dowel joint (not to scale)



4. (continued)

The component drawing for the Cam Dowel is incomplete.

- (d) Apply the British Standard conventions for the screw threads in each view in Figure 6 below.

2

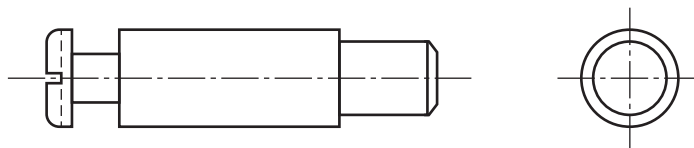

Figure 6

In preparation for manufacture of the table top, the furniture designer has been asked to specify some measurements.

- (e) Calculate how far the wooden dowel protrudes from the table leg when fully inserted.

1

\_\_\_\_\_ mm

- (f) Calculate the minimum depth of hole required to be drilled in the table top to accommodate the Cam Dowel.

1

\_\_\_\_\_ mm

- (g) State the type of linear dimensioning used in the elevation view of the Cam Dowel in Figure 3.

1

\_\_\_\_\_

- (h) State the type of the sectional view in Figure 5.

1

\_\_\_\_\_

[Turn over



\* X 7 3 5 7 6 0 1 1 7 \*

5. Study the magazine pages, read the judges' comments carefully and answer the following questions.

The double page layouts in the magazines have each won graphic design awards.

Below each layout is a comment made by the judges about the success of the layout.

(a)



Judges' comments

“Be yourself – you can’t be anyone else”, an interview with Kelly Osbourne, takes a dynamic image and combines it with the interview in a simple but effective way. The connection with the young female target market is strong and the use of typeface is creative”.

Describe how the designer has used the headline to connect with a target audience and to create visual contrast.

4

5. (continued)

MARKS DO NOT WRITE IN THIS MARGIN

(b)



Judges' comments

“The windsurfing layout captures the excitement of the sport while showing a strongly unified layout across both pages. It uses techniques that connect with its young, sporty target audience.”

(i) Explain the ways in which the designer has used DTP techniques to create unity in the layout. 2

(ii) Describe how the designer used DTP features to introduce proportion in the layout. 2



5. (continued)

(c)



Judges' comments

"The article about T.I. the American rapper and producer, demonstrates clever use of space. The graphic designer took a photograph which oozes attitude and created a clean and modern layout around it. Also, the designer used several clever and subtle tricks to create contrast and visual impact".

The graphic designer uses DTP features to incorporate shape in the layout.

Explain how the designer's use of shape improves the layout.

3



6. A review of music festivals was commissioned by “NEWmusic” magazine. The magazine’s readers are in the 18-28 years age range. The musical styles covered by the magazine are “indie” and “rock”.

Use the two layouts in the **supplementary sheet for use with Question 6** provided to answer this question.

A graphic designer submitted version 1 of his festival review for consideration but this was not accepted for publication. Version 2 was then developed and was published in “NEWmusic” magazine.

The following questions require you to compare how the designer has applied **design elements** and **principles** in each of the versions and describe the impact they have on the layouts.

**Colour** is a feature in both layouts

- (a) Compare the use of **colour** in the layouts.

2

**Alignment** is a consideration whenever a layout is created.

- (b) Compare the use of **alignment** in both layouts.

4



6. (continued)

Designers choose a style of **balance** to suit the purpose of the layout.

(c) Compare the use of **balance** in both layouts.

2

**Texture** can be an important visual feature in a layout.

(d) Compare the use of **texture** in both layouts.

2

Graphic designers use **emphasis** for a number of purposes.

(e) Compare the use of **emphasis** in both layouts.

2

[END OF QUESTION PAPER]



ADDITIONAL SPACE FOR ANSWERS

MARKS  
DO NOT  
WRITE IN  
THIS  
MARGIN



\* X 7 3 5 7 6 0 1 2 3 \*

ADDITIONAL SPACE FOR ANSWERS

MARKS

DO NOT  
WRITE IN  
THIS  
MARGIN



\* X 7 3 5 7 6 0 1 2 4 \*

[BLANK PAGE]

DO NOT WRITE ON THIS PAGE



\* X 7 3 5 7 6 0 1 2 5 \*

[BLANK PAGE]

DO NOT WRITE ON THIS PAGE



\* X 7 3 5 7 6 0 1 2 6 \*

[BLANK PAGE]

DO NOT WRITE ON THIS PAGE



\* X 7 3 5 7 6 0 1 2 7 \*

## ACKNOWLEDGEMENTS

Question 2 – Three images of the Glasgow Riverside Museum of Transport by Zaha Hadid Architects. Reproduced by kind permission of Zaha Hadid Architects.

Question 5(a) – Double page layout from Cosmopolitan, September 2012. Interview by Elaine Lipworth and Photograph by James White.

**SQA has made every effort to trace the owners of copyright materials reproduced in this question paper, and seek permissions. We will be happy to incorporate any missing acknowledgements. Please contact [Janine.Anderson@sqa.org.uk](mailto:Janine.Anderson@sqa.org.uk).**

Question 5(b) – Double page layout from Extreme sports magazine is taken from [cargocollective.com/danmackay](http://cargocollective.com/danmackay). Reproduced by permission of Dan Mackay.

Question 5(c) – Double page layout from Vibe Magazine, May 5 2007. Article by Hillary Crosley and Photograph by Kaseem Black.

**SQA has made every effort to trace the owners of copyright materials reproduced in this question paper, and seek permissions. We will be happy to incorporate any missing acknowledgements. Please contact [Janine.Anderson@sqa.org.uk](mailto:Janine.Anderson@sqa.org.uk).**



\* X 7 3 5 7 6 0 1 2 8 \*



National  
Qualifications  
2015

**X735/76/11**

**Graphic Communication  
Supplementary Sheet**

THURSDAY, 30 APRIL

1:00 PM – 3:00 PM

Supplementary sheet for use with Question 6



\* X 7 3 5 7 6 1 1 \*

# Festivals

## 2013

### UTunes



The UTunes Festival. 30 days of live music from the biggest bands and artists. This jam-packed festival ranged from bands such as Kings of Leon to artists such as Avicii. For anybody who enjoys seeing all of the big bands this is the festival to go to.

### Blastin Merry



Blastin' Merry 2013 sure was a festival to relish. Artists such as Example, Chase and Status, the Rolling Stones, Mumford and Sons and many more contributed to the extremely action packed, enjoyable Festival that everyone seems to know and love. The Rolling Stones made the most impact on festival goers and people of all ages enjoyed their music.

### R&R on the Farm

From Headliners such as Rihanna, Mumford and Sons to Jake Bugg and Alt-J, R&R on the Farm made it big this year. A year in which 'R&R' celebrated its 20th anniversary as the biggest and perhaps best Scottish music festival.



Christian Bertrand/Shutterstock.com

Fans were treated to nice weather too which made a welcome and well deserved change to the weather conditions at recent festivals. It all added up to make Galado a magical place for the entire weekend.



# Festivals 2013

## R&R on the Farm

**F**rom Headliners such as Rihanna, Mumford and Sons to Jake Bugg and Alt-J, R&R on the Farm made it big this year. A year in which 'R&R' celebrated its 20th anniversary as the biggest and perhaps best Scottish music festival. Fans were treated to nice weather too which made a welcome and well deserved change to the weather conditions at recent festivals. It all added up to make Galardo a magical place for the entire weekend.



Christian Bertrand/Shutterstock.com

## Blastin' Merry



Dziurek/Shutterstock.com

**B**lastin' Merry 2013 sure was a festival to relish. Artists such as Example, Chase and Status, the Rolling Stones, Mumford and Sons and many more contributed to the extremely action packed, enjoyable Festival that everyone seems to know and love. The Rolling Stones made the most impact on festival goers and people of all ages enjoyed their music.

## UTunes

**T**he UTunes Festival. 30 days of live music from the biggest bands and artists. This jam-packed festival ranged from bands such as Kings of Leon to artists such as Avicii. For anybody who enjoys seeing almost all of the big bands this is the festival to go to.



## ACKNOWLEDGEMENTS

Supplementary Sheet for use with Question 6 – [melis/shutterstock.com](https://www.shutterstock.com/user/melis)  
[Christian Bertrand/shutterstock.com](https://www.shutterstock.com/user/Christian-Bertrand)  
[Dziurek/shutterstock.com](https://www.shutterstock.com/user/Dziurek)  
[Maxim Blinkov/shutterstock.com](https://www.shutterstock.com/user/Maxim-Blinkov)