

FOR OFFICIAL USE



--	--	--	--	--	--

National
Qualifications
2016

Mark

--

X735/76/01

Graphic Communication

TUESDAY, 10 MAY

1:00 PM – 3:00 PM



Fill in these boxes and read what is printed below.

Full name of centre

Town

--

Forename(s)

Surname

Number of seat

--

--

--

Date of birth

Day

Month

Year

Scottish candidate number

--	--

--	--

--	--

--	--	--	--	--	--	--	--	--	--

Total marks — 70

Attempt ALL questions.

All dimensions are in mm.

All technical sketches and drawings use third angle projection.

You may use rulers, compasses or trammels for measuring.

In all questions you may use sketches and annotations to support your answer if you wish.

Write your answers clearly in the spaces provided in this booklet. Additional space for answers is provided at the end of this booklet. If you use this space you must clearly identify the question number you are attempting.

Use **blue** or **black** ink.

Before leaving the examination room you must give this booklet to the Invigilator; if you do not, you may lose all the marks for this paper.



Attempt ALL questions

Total marks — 70

MARKS

DO NOT
WRITE IN
THIS
MARGIN

1. A CAD technician created the 3D CAD model of an electric guitar.



The technician made use of a **CAD Library** in the production of the guitar 3D CAD model.

- (a) Describe **two** benefits of using a CAD library.

2

The 3D CAD model of the guitar will be used to create production and promotional graphics.

- (b) Describe **one** benefit of using 3D CAD models in:

- (i) Advertising

1

- (ii) Manufacturing

1



* X 7 3 5 7 6 0 1 0 2 *

1. (continued)

MARKS
DO NOT WRITE IN THIS MARGIN

An exploded view and a partial enlargement of the guitar are shown below.

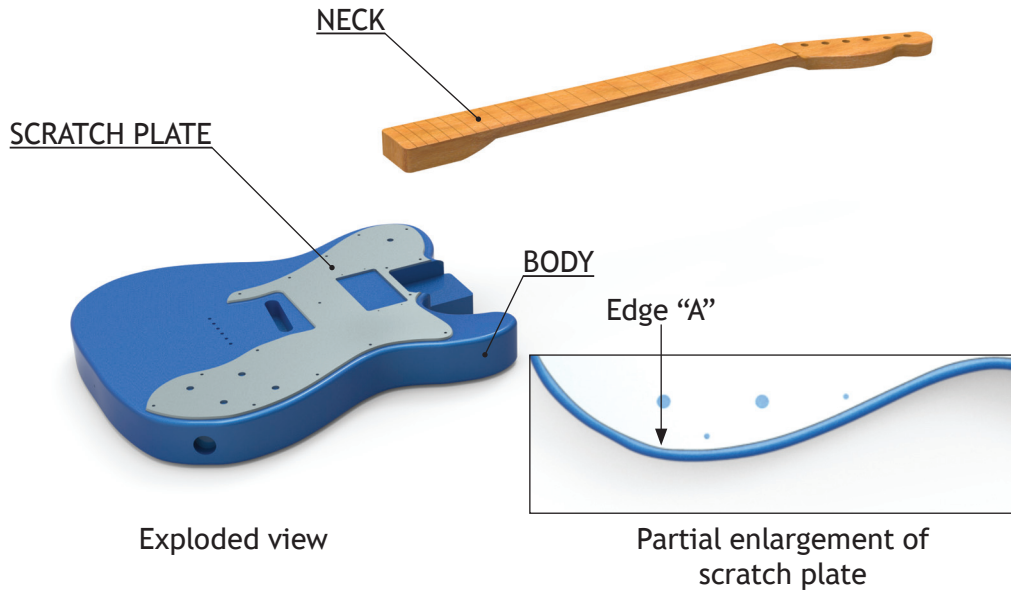

The CAD technician used the process of **top down modelling** to ensure the neck would fit with the body.

(c) Describe the process of **top down modelling**.

2

You may use sketches to support your answer.

The CAD technician wanted the scratch plate to follow the same shape as the body.

(d) (i) State the name of the 2D CAD tool used to ensure the scratch plate was the same shape as the guitar body at **Edge A**, shown above.

1

(ii) Describe how this 2D CAD tool was used.

1

You may use sketches to support your answer.



1. (continued)

A production drawing for a control dial for the guitar is shown below.

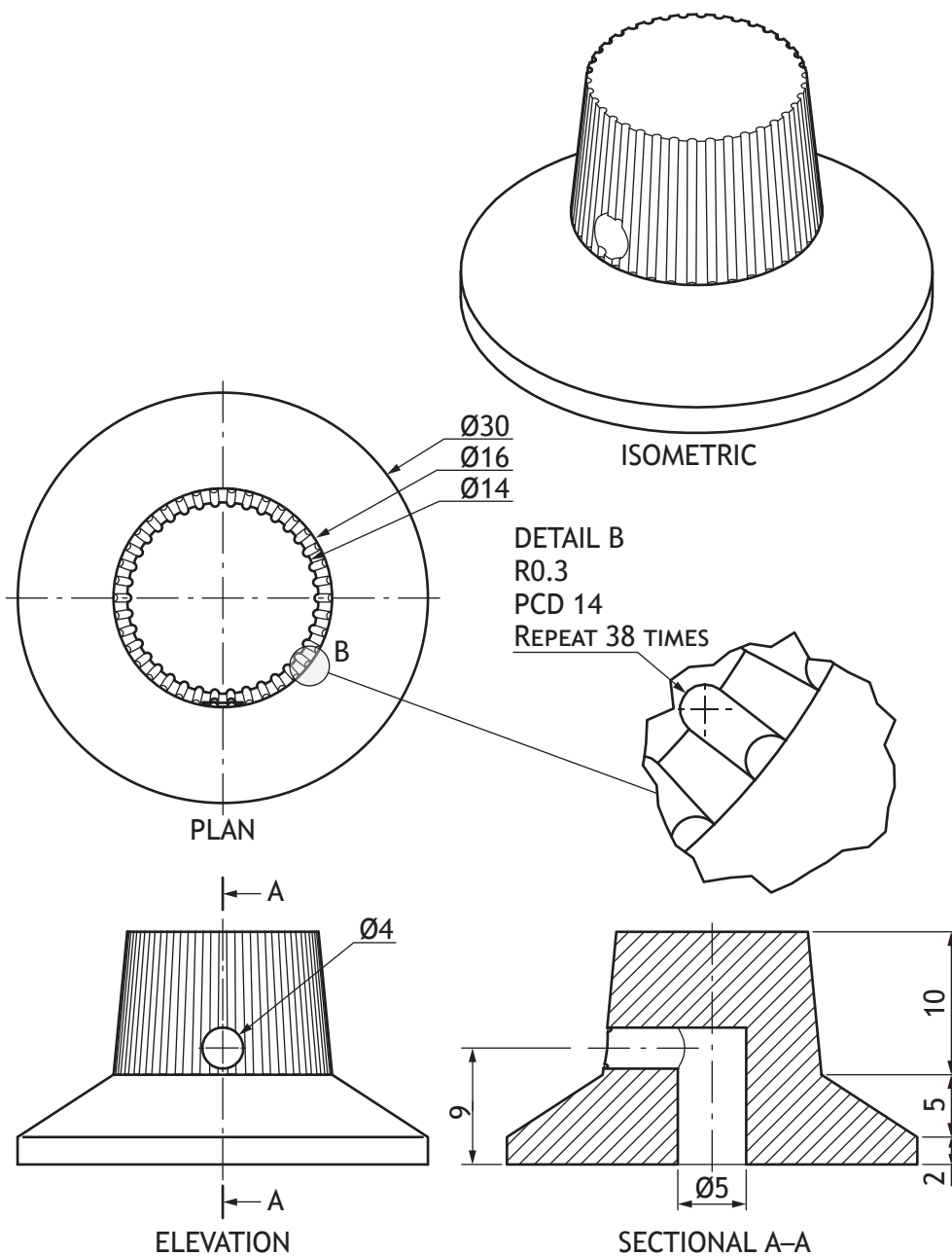

1. (continued)

MARKS

DO NOT
WRITE IN
THIS
MARGIN

- (e) Describe the 3D CAD modelling techniques required to produce the control dial. Make reference to the dimensions given in the production drawing. You may use sketches to support your answer.

8



* X 7 3 5 7 6 0 1 0 5 *

1. (continued)

MARKS
DO NOT
WRITE IN
THIS
MARGIN

An incomplete elevation and a rendered pictorial drawing of a component of the guitar are shown below.

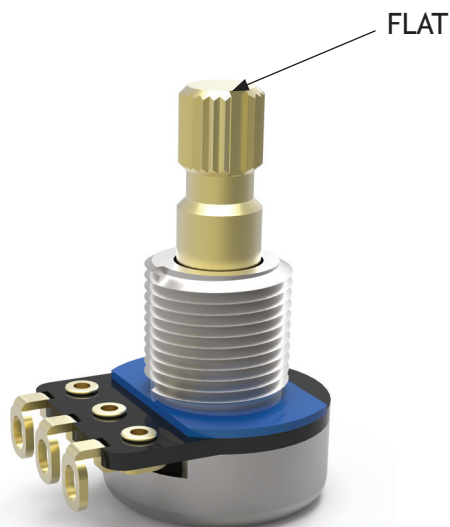
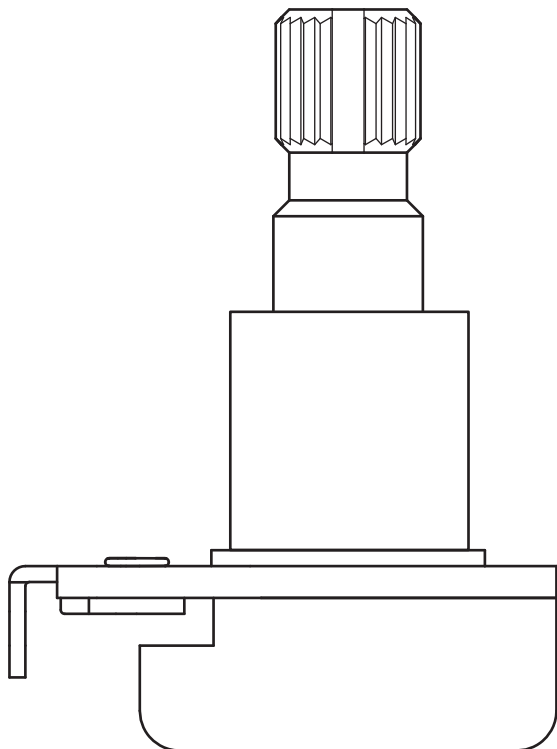

(f) Add the British Standard conventions in the correct location on the incomplete elevation for:

(i) Thread

1

(ii) Flat on shaft

1



1. (continued)

MARKS

DO NOT
WRITE IN
THIS
MARGIN

The headstock for the guitar is shown below. The headstock was modelled using the principles of tangency.

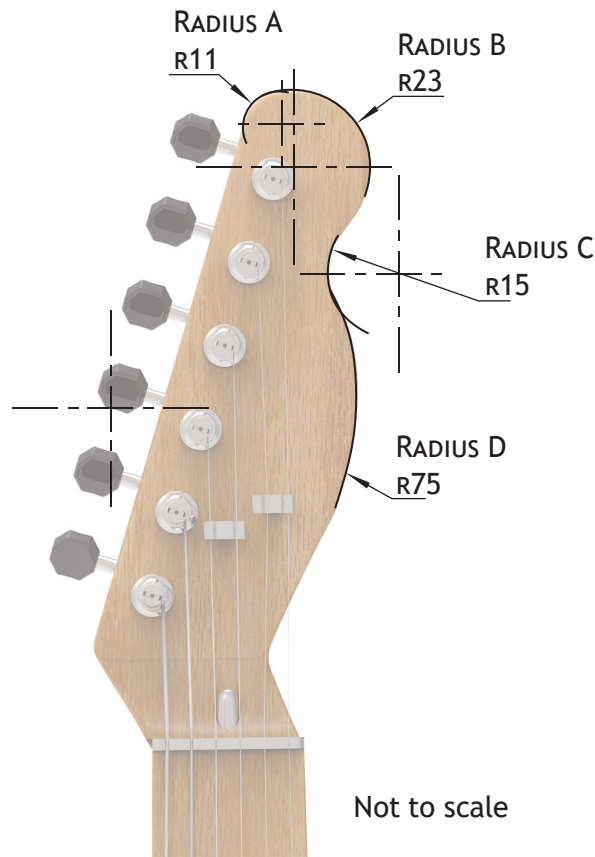

- (g) (i) Calculate the distance from the centre of **radius C** to the centre of **radius D**.

1

- (ii) Calculate the distance from the centre of **radius A** to the centre of **radius B**.

1



1. (continued)

MARKS
DO NOT
WRITE IN
THIS
MARGIN

The 3D CAD model of the guitar neck and a part model are shown below.

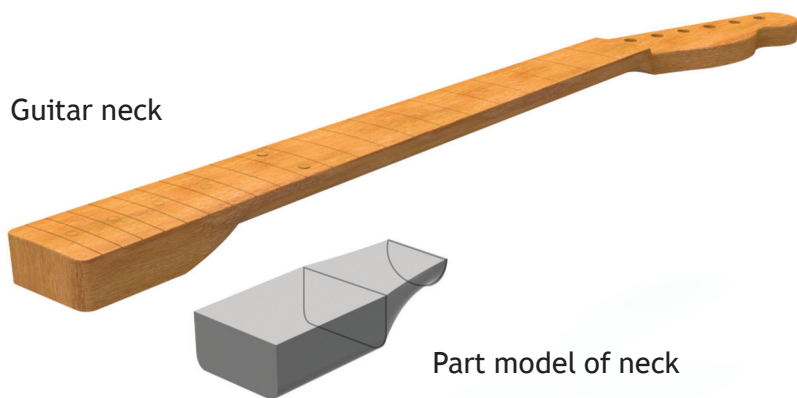

(h) Describe the 3D CAD modelling technique used to create the part model of the neck shown above.

3

You may use sketches to support your answer.



2. A fashion magazine, aimed at 25–35 year old females, is producing an article on sunglasses. A graphic designer created a draft layout for the article shown below.



- (a) Describe the effects the graphic designer has created in the layout by using the following.

(i) White Space

2

(ii) Colour

2



* X 7 3 5 7 6 0 1 0 9 *

2. (a) (continued)

(iii) Typeface

2

(b) Explain how the graphic designer has used **proportion** in the layout.

4

(c) Describe how the designer has created **depth** in the layout.

2

(d) Describe how **line** has been used to enhance the layout.

2



* X 7 3 5 7 6 0 1 1 0 *

2. (continued)

MARKS
DO NOT
WRITE IN
THIS
MARGIN

The Ray Ban logo was made available in a vector file format.



(e) Explain **two** advantages of using a vector file format in the production of the layout.

2

[Turn over



* X 7 3 5 7 6 0 1 1 1 *

2. (continued)

The final layout for the article is shown below.



The final layout was produced in layers using DTP software.



* X 7 3 5 7 6 0 1 1 2 *

2. (continued)

- (f) Describe **three** advantages to the graphic designer of using layers for this layout.

3

The graphic designer has used different types of justification for the sub-heading and main body text of the layout.

- (g) Explain why the graphic designer has chosen to do this for:

- (i) The sub-heading

1

- (ii) The main body text

1

[Turn over



* X 7 3 5 7 6 0 1 1 3 *

Pre-Press Layout



The pre-press layout shown above contains crop and registration marks.

- (h) (i) Explain why the yellow boxes bleed beyond the crop marks. 1

- (ii) Describe the purpose of registration marks in printing. 2



[Turn over for next question

DO NOT WRITE ON THIS PAGE



* X 7 3 5 7 6 0 1 1 5 *

3. Dundee Waterfront is undergoing a £1 billion redevelopment.

The official website includes various types of graphics aimed at promoting the development to the local community. These include:

- **Location plans** of the entire development
- **Site plans** of some of the new proposed buildings

(a) Describe the features for **both** types of plans for providing information about the redevelopment to the local community.

4

A selection of rendered CAD pictorial images of the new train station were uploaded to the website.



3. (continued)

MARKS

DO NOT
WRITE IN
THIS
MARGIN

- (b) Explain **three** advantages of using rendered CAD pictorials to communicate the design to the local community.

3

The architect shared initial sketches of a building idea on the website. These sketches were created using pencil and marker pen.

- (c) (i) Describe how the manual sketches can be converted to digital images for use on the website.

1

- (ii) Explain why a **jpeg** would be a suitable file format for these images.

1

More initial sketches were “digitally sketched” on a touch-screen tablet.

- (d) Describe **two** advantages to the architect of using digital sketching.

2

[Turn over



* X 7 3 5 7 6 0 1 1 7 *

4. An exploded CAD illustration of a castor wheel assembly is shown below.

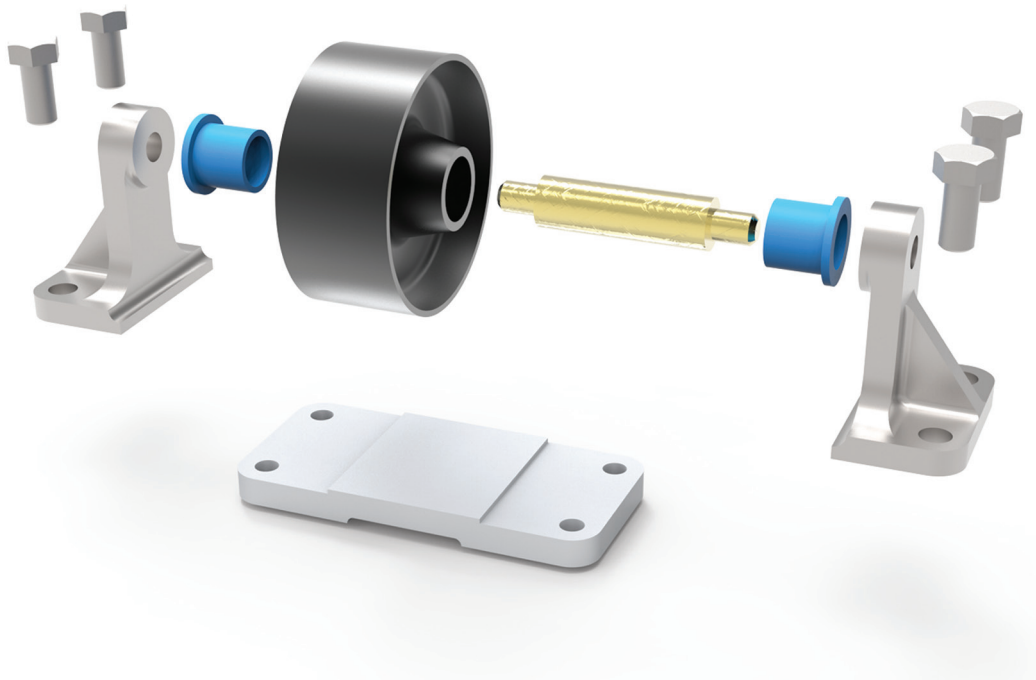

The assembly is made up of several parts that includes four M12 bolts.

The **plan** and **incomplete stepped sectional elevation A-A** are shown on the opposite page.

Complete section A-A by applying hatching lines to appropriate areas in accordance to British Standards.

5



* X 7 3 5 7 6 0 1 1 8 *

4. (continued)

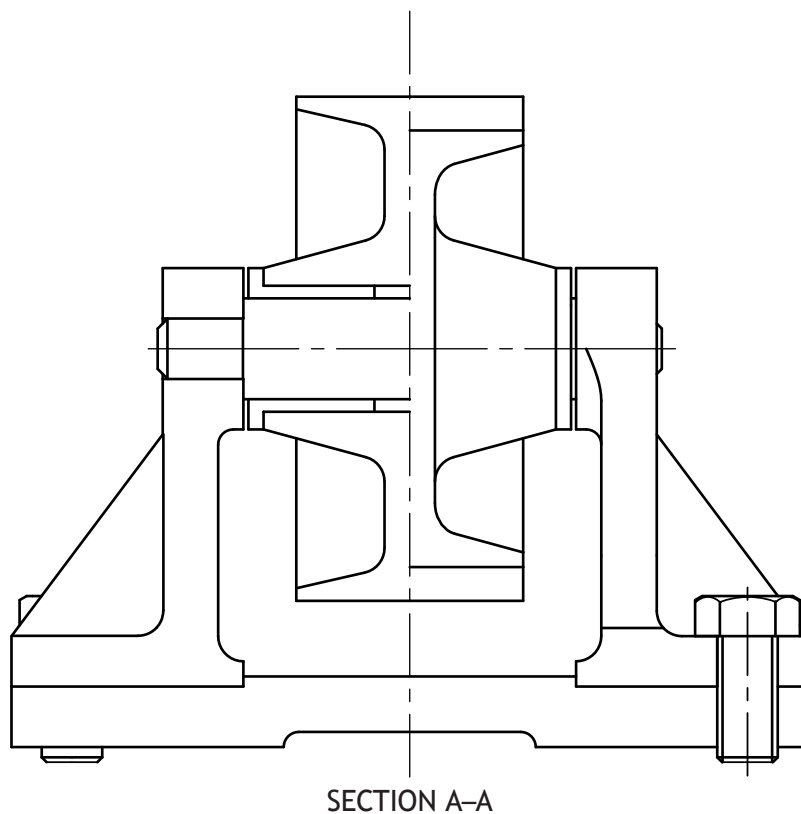
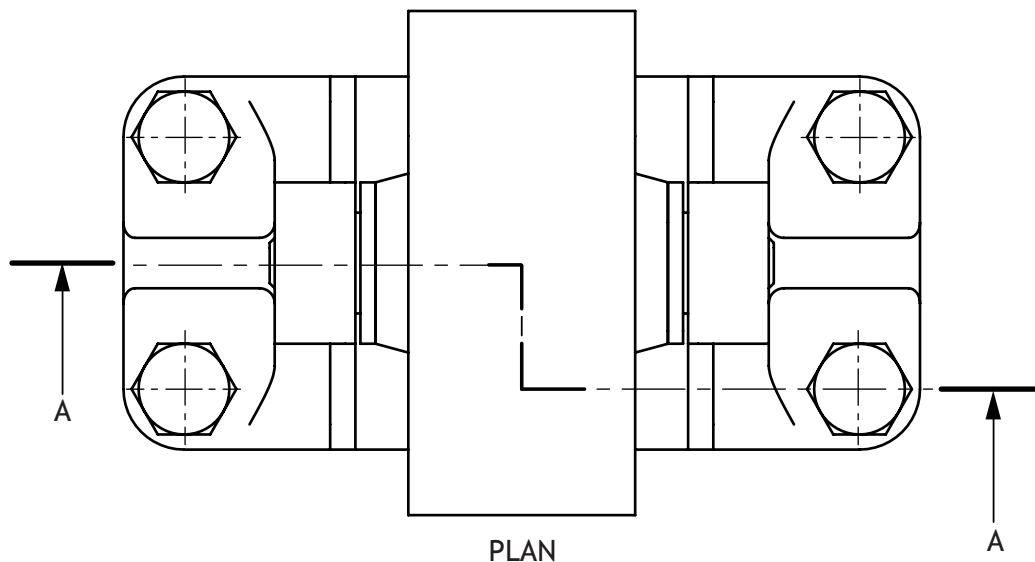

5. A building company is planning a new residential area. The plan shown below has been illustrated for potential customers.

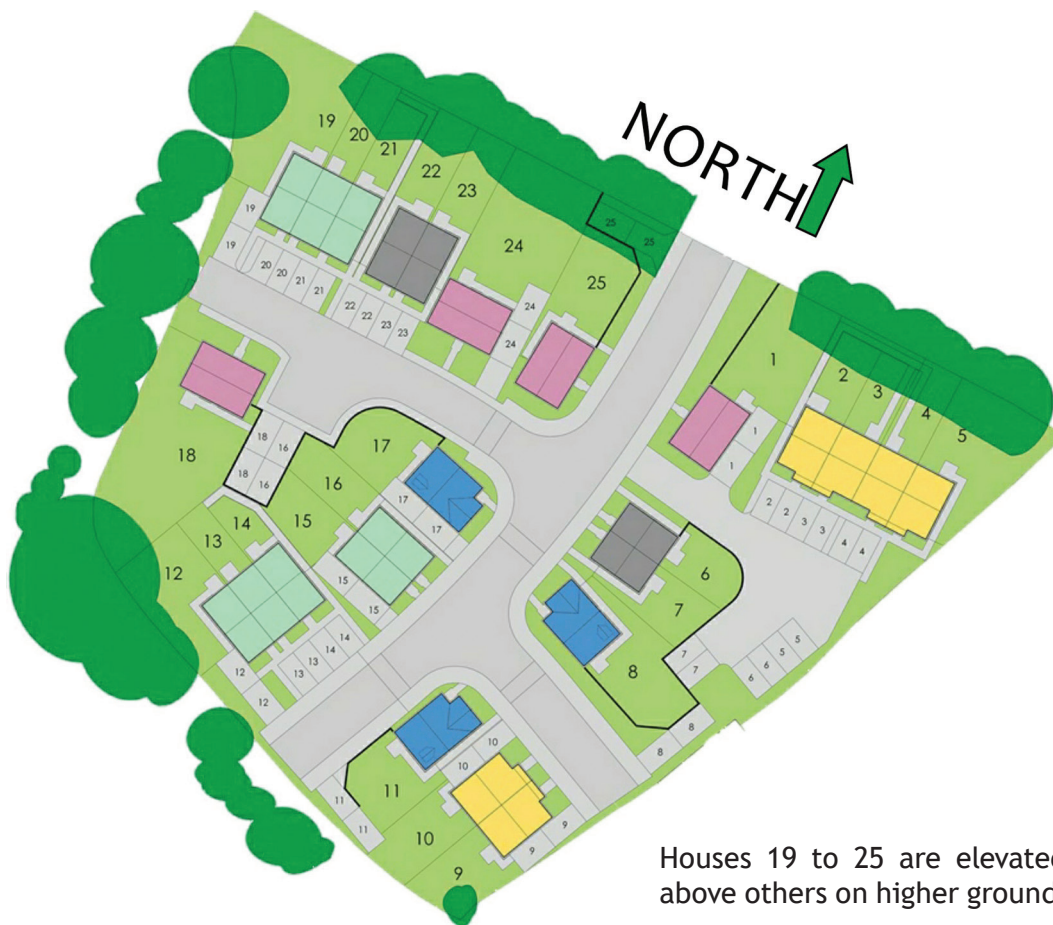

The drawing does not use **British Standard** conventions.

- (a) Identify **three** features of **this drawing** which should be shown on a **British Standards** location plan.

3



* X 7 3 5 7 6 0 1 2 0 *

5. (continued)

MARKS
DO NOT
WRITE IN
THIS
MARGIN

A 3D model of one of the house styles is shown below.



(b) State the total number of houses of this style in the location plan.

1

The architect used the following symbols in drawings of the floor plan

(c) State the correct name for the following symbols.

3

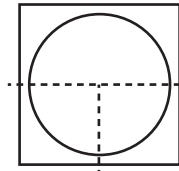
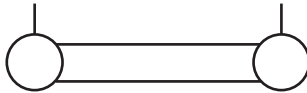
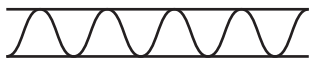

(i) _____ (ii) _____ (iii) _____

[END OF QUESTION PAPER]



* X 7 3 5 7 6 0 1 2 1 *

MARKS

DO NOT
WRITE IN
THIS
MARGIN

ADDITIONAL SPACE FOR ANSWERS



* X 7 3 5 7 6 0 1 2 2 *

MARKS

DO NOT
WRITE IN
THIS
MARGIN

ADDITIONAL SPACE FOR ANSWERS



* X 7 3 5 7 6 0 1 2 3 *

ACKNOWLEDGEMENTS

Question 2 (Image is used behind the word “FAB”) – Image is taken from http://wallpaperswide.com/blue_jeans_and_white_shirt-wallpapers.html. (Author: Unknown).

SQA has made every effort to trace the owners of copyright materials reproduced in this question paper, and seek permissions. We will be happy to incorporate any missing acknowledgements. Please contact Janine.Anderson@sqa.org.uk.

Question 2 – Image of blonde girl wearing sunglasses is taken from http://therooster.sparepartslife.com/wp-content/uploads/2014/07/MG_4434.jpg.

SQA has made every effort to trace the owners of copyright materials reproduced in this question paper, and seek permissions. We will be happy to incorporate any missing acknowledgements. Please contact Janine.Anderson@sqa.org.uk.

Question 2 – Image is taken from <http://rheabue.com/i-see-crop/>.

SQA has made every effort to trace the owners of copyright materials reproduced in this question paper, and seek permissions. We will be happy to incorporate any missing acknowledgements. Please contact Janine.Anderson@sqa.org.uk.

Question 2 – Ray-Ban images and logos.

SQA has made every effort to trace the owners of copyright materials reproduced in this question paper, and seek permissions. We will be happy to incorporate any missing acknowledgements. Please contact Janine.Anderson@sqa.org.uk.

Question 3 – Two images of Dundee Station by Nicoll Russell Studios. Reproduced by kind permission of Nicoll Russell Studios.



* X 7 3 5 7 6 0 1 2 4 *