



Higher Graphic Communication Assignment Assessment task

This document provides information for teachers and lecturers about the coursework component of this course in terms of the skills, knowledge and understanding that are assessed. It **must** be read in conjunction with the course specification.

Valid for session 2018-19 only.

The information in this publication may be reproduced in support of SQA qualifications only on a non-commercial basis. If it is reproduced, SQA must be clearly acknowledged as the source. If it is to be reproduced for any other purpose, written permission must be obtained from permissions@sqa.org.uk.

Where this publication includes material for which SQA does not own the copyright, this material must only be reproduced on a non-commercial basis for the purposes of instruction in an educational establishment. If it is to be reproduced for any other purpose, it is the user's responsibility to obtain the necessary copyright clearance from the copyright owner. The acknowledgements page lists the owners of copyright items that are not owned by SQA.

This edition: January 2019 (version 1.0)

© Scottish Qualifications Authority 2019

Contents

Introduction	1
Instructions for teachers and lecturers	2
Instructions for candidates	6

Introduction

This document contains instructions for teachers and lecturers, and instructions for candidates for the Higher Graphic Communication assignment. You must read it in conjunction with the course specification.

This assignment is worth 50 marks. This is 36% of the overall marks for the course assessment.

This is one of two course assessment components. The other component is a question paper.

Instructions for teachers and lecturers

SQA publishes a new assessment task on the secure website each academic year. The task is valid for that year only. Once complete, you must send the assignment responses to SQA to be marked.

You must conduct the assignment under a high degree of supervision and control. This means:

- ◆ candidates must be within your direct sight
- ◆ candidates must not interact with each other
- ◆ candidates must not have access to e-mail, the internet and mobile phones
- ◆ candidates must complete their work independently – no group work is permitted
- ◆ classroom display materials that might provide assistance must be removed or covered
- ◆ with no interruption for learning and teaching
- ◆ in a classroom environment

Time

Candidates have 8 hours to complete the assignment, starting at an appropriate point in the course after all content has been delivered. Once candidates begin, they must continue in each subsequent class period until the permitted time allocation has been used up.

You have a responsibility to manage candidates' work, distributing it at the beginning and collecting it at the end of each session, and storing it securely in between. This activity does not count towards the total time permitted for candidates to complete the assignment.

Resources

This is a closed-book assessment. Candidates must not have access to learning and teaching materials, the internet, notes, exemplar materials, resources on classroom walls or anything similar.

There may be instances where restriction of internet and/or network use is prohibited (for example, if you have a local authority-managed network with specific limitations or CAD software that is web-based). However, it remains your professional responsibility to make every effort to meet the assessment conditions.

Each assessment task includes instructions and details of any equipment or materials required. Candidates can also use normal classroom equipment, software and hardware (such as drawing instruments, CAD and DTP software, and PCs to run the software) to complete the tasks.

Candidates can use a premade or existing A3 CAD template.

Reasonable assistance

Candidates must progress through each stage of the assignment without your intervention or guidance, having acquired the skills earlier in the course.

Once candidates complete the assignment, you must not return it to them for further work. You must not provide feedback to candidates or offer an opinion on the perceived quality or completeness of the assignment response, at any stage.

You can provide reasonable assistance to support candidates with the following aspects of their assignment:

- ◆ Printing, collating, stapling and labelling their evidence to ensure it is in the format specified by SQA.
- ◆ Ensuring candidates have all the materials and equipment required to complete the assignment.
- ◆ Understanding the information outlined in these instructions.

Evidence

All candidate evidence (whether created manually or electronically) must be submitted to SQA in a paper-based format.

Each task details what evidence is required and how many pages are expected. This is a guide to ensure that candidates do not produce too much work or spend too long on a single task. Single-sided A3 pages are preferred and are typically the most suitable for the tasks; however, it is acceptable to submit A4 pages, if no suitable A3 printer is available.

Each piece of work must be labelled with the task number, for example, task 3a, and the back of each page must be clearly labelled with candidate details.

Alteration or adaptation

You must not alter, adapt or modify the assignment in any way. This includes moving the content of the assignment into a different format or workbook. All candidates must undertake the assignment exactly as it is provided.

Volume

Candidates should present their work on a maximum of 10 single-sided A3-sized pages.

This figure is given to indicate the volume of evidence required; however, no penalty is applied where candidates exceed this. Full details of evidence requirements are contained within each assessment task.

Specific instructions for teachers and lecturers: portable speaker

You must follow these specific instructions. You must ensure that candidates are aware of the assessment conditions and know what they should do for each task.

Prior to candidates starting the assignment, you must download the following electronic files for their use. You must keep these files secure and candidates must not access them prior to assessment.

- ◆ data sheet 7 – copy text
- ◆ data sheet 7 – graphic of the logo
- ◆ data sheet 8 – graphic of a guitar fretboard
- ◆ data sheet 8 – graphic of an electric guitar
- ◆ data sheet 8 – graphic of a hardware interface
- ◆ data sheet 8 – graphic of a mixing desk
- ◆ data sheet 8 – graphic of a speaker mesh
- ◆ data sheet 8 – graphic of a speaker
- ◆ data sheet 8 – graphic of a microphone
- ◆ data sheet 8 – graphic of a condenser microphone
- ◆ data sheet 8 – graphic of a wireless symbol
- ◆ STEP files of a desk lamp, guitar plectrums, speaker components and a 3.5mm jack cable

This assignment has three tasks. Candidates must complete the tasks in order.

Each task has a notional time allocated to it.

Task 1 – 20 marks

(suggested time 3 hours)

- ◆ tasks a to d: production drawings must be produced electronically and generated from a 3D CAD model produced by the candidate

Task 2 – 22 marks

(suggested time 3 hours)

- ◆ task 2a: must be completed electronically
- ◆ task 2b: may be completed manually or electronically – candidates must produce two preliminary layouts/thumbnails of a folding leaflet
- ◆ task 2c: must be completed electronically – candidates must label where they have used rhythm and depth

Task 3 – 8 marks

(suggested time 2 hours)

- ◆ task 3a: it is expected that this will be completed manually – if an electronic method is used, it must not be 3D CAD software (candidates will gain no marks if this software is used)
- ◆ task 3b: must be completed electronically – candidates must label where they have used DTP techniques taken from the following list: cropping, rotate, transparency, reverse, bleed, flow text along a path, drop shadow, colour fill

Note: candidates must not trace drawings for any part of the assignment – they will gain no marks for traced drawings.

All electronically-generated evidence must be printed and compiled for uplift by SQA.

Instructions for candidates

This assessment applies to the assignment for Higher Graphic Communication.

This assignment is worth 50 marks. This is 36% of the overall marks for the course assessment. It assesses the following skills, knowledge and understanding:

- ◆ creativity when responding to graphic design tasks and situations
- ◆ using graphic communication technologies to meet a purpose
- ◆ producing preliminary, production and promotional graphic items in response to a situation or problem
- ◆ applying illustration and presentation techniques to create graphics with relevant visual impact
- ◆ producing 2D and 3D production drawings, applying appropriate standards, protocols and conventions
- ◆ producing promotional graphic publications to meet an agreed content and style
- ◆ reviewing and evaluating your progress, giving justification for your choice of graphic items and the graphic communication techniques employed

This is a closed-book assessment. Your teacher or lecturer will let you know if there are any specific conditions for doing this assessment.

Note: you must not trace drawings for any part of the assignment – you will gain no marks for traced drawings.

In this assessment, you have to produce a range of graphics in response to a brief:

- ◆ in the order presented
- ◆ which assess aspects of the skills and knowledge listed above
- ◆ in 8 hours, excluding the time needed to set up and clear away any equipment, and for any printing that is required

You are not permitted to use any text, images or other items from any other source unless created by yourself within the 8-hour assignment.

There are three tasks, with marks allocated as follows:

Task 1 – 20 marks: producing production drawings for a portable speaker
(suggested time 3 hours)

Task 2 – 22 marks: producing preliminary and promotional graphics for the portable speaker and a folding leaflet
(suggested time 3 hours)

Task 3 – 8 marks: producing preliminary and promotional graphics for the luggage tag and luggage tag graphic
(suggested time 2 hours)

Your teacher or lecturer will provide you with:

- ◆ tasks sheets 1 to 3 – graphic communication briefs, including some initial research information
- ◆ data sheets 1 to 9
- ◆ STEP files of a desk lamp, a guitar plectrum, speaker components, and a 3·5mm jack cable
- ◆ electronic files of the graphics shown in data sheets 7 and 8

Submitting your work

You must label each piece of evidence with the task number (for example task 3a), and the back of each page with your:

- ◆ name
- ◆ date of birth
- ◆ Scottish Candidate Number (SCN)
- ◆ centre name
- ◆ centre number

Graphic Communication brief

Online music company LWR Music is developing a new portable speaker and is hoping to attract young people and musicians to purchase it.

Initial market research has identified that people are looking for a speaker that is **inexpensive**, and incorporates a **simple colour scheme**, with a **mixture of different materials**.

As part of the graphic proposal, LWR Music has asked you to create:

- ◆ production drawings to manufacture the portable speaker casing
- ◆ a promotional item for the portable speaker, with relevant desktop-published graphics that will be distributed inside customer order packages.

You have been provided with the following:

- a company logo, font and colours
- copy text
- several pre-approved promotional images

Note: you cannot alter the company name, logo, font or company colours

You have data sheets to guide you through the assignment.

Task 1: portable speaker

A graphic artist has produced a series of sketches to aid the manufacture of the portable speaker casing.

Using the preliminary sketches and information shown on data sheets 1, 2, 3, 4 and 5, model and assemble the speaker casing components using 3D CAD software.

From these models, produce production drawings that will allow the speaker casing to be manufactured.

You may use top-down modelling or bottom-up modelling in your work. You must produce views in the same orientation as each individual data sheet.

1a (i) Produce, at a scale of 1:1, an elevation, a plan, and a sectional end elevation through the cutting plane of the back casing (Data sheet 2, part 1).

(ii) Produce, at a scale of 1:1, an elevation, a plan, and a sectional end elevation through the cutting plane of the front casing (Data sheet 3, part 2).

Your drawings must be complete with hidden detail, appropriate dimensions for manufacture and annotations.

(6 marks)

1b Produce an elevation, a plan, and a stepped sectional end elevation of the assembled speaker casing. This must be at a scale of 1:1 to show how the front casing (Data sheet 3, part 2) and the speaker disc (Data sheet 4, part 3) fit together, and how the back casing (Data sheet 2, part 1) and the stabilising rod (Data sheet 5, part 4) fit together.

Your drawing should include an enlarged detail view to show how the front casing (data sheet 3, part 2) and the speaker disc (Data sheet 4, part 3) fit together.

Do not show hidden detail or add dimensions to assembled views.

(8 marks)

1c Produce an exploded isometric view of the assembled speaker casing.

(3 marks)

1d Include correct British Standard conventions and line types on all of your drawings.

(3 marks)

Note: you must create the production drawings for task 1 electronically and print out your work.

You should complete task 1 on three or four single-sided A3-sized pages.

You should spend approximately 3 hours on task 1.

Your completed assignment (tasks 1 to 3) should be on no more than 10 single-sided A3-sized pages.

Task 2: portable speaker and promotional item

LWR Music will be distributing a promotional leaflet for the speaker inside the packaging for customer orders.

Initial market research has identified that people are looking for a speaker that:

- ◆ incorporates a simple colour scheme and a mixture of different materials
- ◆ has memorable branding and a positive product identity

Produce preliminary and promotional graphics for the portable speaker, using the information on data sheets 6, 7 and 8, and the following instructions.

- 2a Using the assembled speaker casing you created in task 1, produce a 3D CAD rendered pictorial illustration of your speaker in a simple scene.

Your illustration should include:

- ◆ the assembled speaker casing and at least one of the STEP files provided, placed in a suitable scene. Illustrated examples of the STEP files are provided on data sheet 6
- ◆ the logo from data sheet 7 attached to at least one component part
- ◆ two walls and a flat surface (counter, shelf or tabletop) with appropriate materials attached to them
- ◆ appropriate colours, materials, highlights, shadows and textures applied to speaker casing components and STEP file(s)

(7 marks)

- 2b Produce two preliminary layouts/thumbnails of both sides of a folding leaflet, using data sheets 7 and 8.

Your layouts/thumbnails must include:

- ◆ the design principles of rhythm and depth
- ◆ the assembled speaker from task 1
- ◆ the company name, logo, colours and copy text from data sheet 7
- ◆ at least two images from data sheet 8

You can add any other graphic items you wish, however, you must create them within the 8 hours of this assignment.

You can use the images on data sheet 8 as they are, or you can edit them to suit your design.

(3 marks)

2c Produce a full-size version of both sides of your folding leaflet using one of your preliminary layouts/thumbnails.

This must be complete with the assembled speaker, company name, logo, copy text and your chosen images. You must identify and fully justify where you have used rhythm and depth in your layout.

You must use:

- ◆ the design features given on data sheet 7 - company name, font style, logo, colour scheme and copy text
- ◆ at least two images from data sheet 8
- ◆ the assembled speaker from task 1
- ◆ the sizes shown on data sheet 7

(12 marks)

Note: you must produce tasks 2a and 2c electronically and print out your work. You can complete task 2b manually or electronically – if electronically, you must print out your work.

You should complete task 2 on three or four single-sided A3-sized pages.

You should spend approximately 3 hours on task 2.

Your completed assignment (tasks 1 to 3) should be on no more than 10 single-sided A3-sized pages.

Task 3: musical instrument luggage tag

As part of LWR Music's overall promotional campaign, customer order packages will include the promotional folding leaflet for the speaker and a free luggage tag for musical instruments.

Data sheet 9 contains information on the proposed luggage tag.

For the graphic proposal, you have to create:

- ◆ an exploded pictorial sketch of the luggage tag, appropriately illustrated to showcase the intended colour
- ◆ relevant graphics for a 2-sided luggage tag, which effectively promotes the company. You have been provided with the following:
 - a company font, colours
 - several pre-approved promotional images

Note: you cannot alter the company font, colours or copy text

You will not gain any marks if you measure, trace or use any drawing instruments (other than a straight edge).

- 3a Produce preliminary and promotional graphics for the luggage tag, using the information on data sheets 8 and 9.

Sketch an exploded pictorial view of the luggage tag.

Your pictorial sketch must include parts A, B and C from data sheet 9, and meet the following criteria:

- ◆ Your pictorial sketch must demonstrate the appropriate assembly methods for the three sketched components.
- ◆ Your pictorial sketch must include appropriate highlights and shadows.
- ◆ Parts A and C must be illustrated using either the colour blue or orange.
- ◆ Part B can remain unillustrated and can be sketched pictorially as a simple cuboid.

(4 marks)

- 3b Produce promotional layouts for sides 1 and 2 of part B of the luggage tag and printout both sides of the graphic to a scale of 2:1.

You do not need to use the LWR Music company logo from task 2, but you can if you wish.

You are not required to submit preliminary planning activities for task 3b.

You must make use of:

- ◆ the design features given on data sheet 9 – copy text, font style and colour scheme
- ◆ at least one image from data sheet 8
- ◆ a minimum of three desktop-publishing techniques from the following list: cropping, rotate, transparency, reverse, bleed, flow text along a path, drop shadow, and colour fill

You can add any other graphic items you wish, however, you must create them within the 8 hours of this assignment.

You can use the images on data sheet 8 as they are, or you can edit them to suit your design.

On your scale 2:1 printout, you must clearly label and justify your three desktop-publishing techniques.

(4 marks)

Note: you can complete task 3a manually or electronically – if electronically, you must print out your work.

You must complete task 3b electronically and print out your work.

You should complete task 3 on one or two single-sided A3-sized pages.

You should spend approximately 2 hours on task 3.

Your completed assignment (tasks 1 to 3) should be on no more than 10 single-sided A3-sized pages.

Data sheet 1 – sketches of speaker casing components

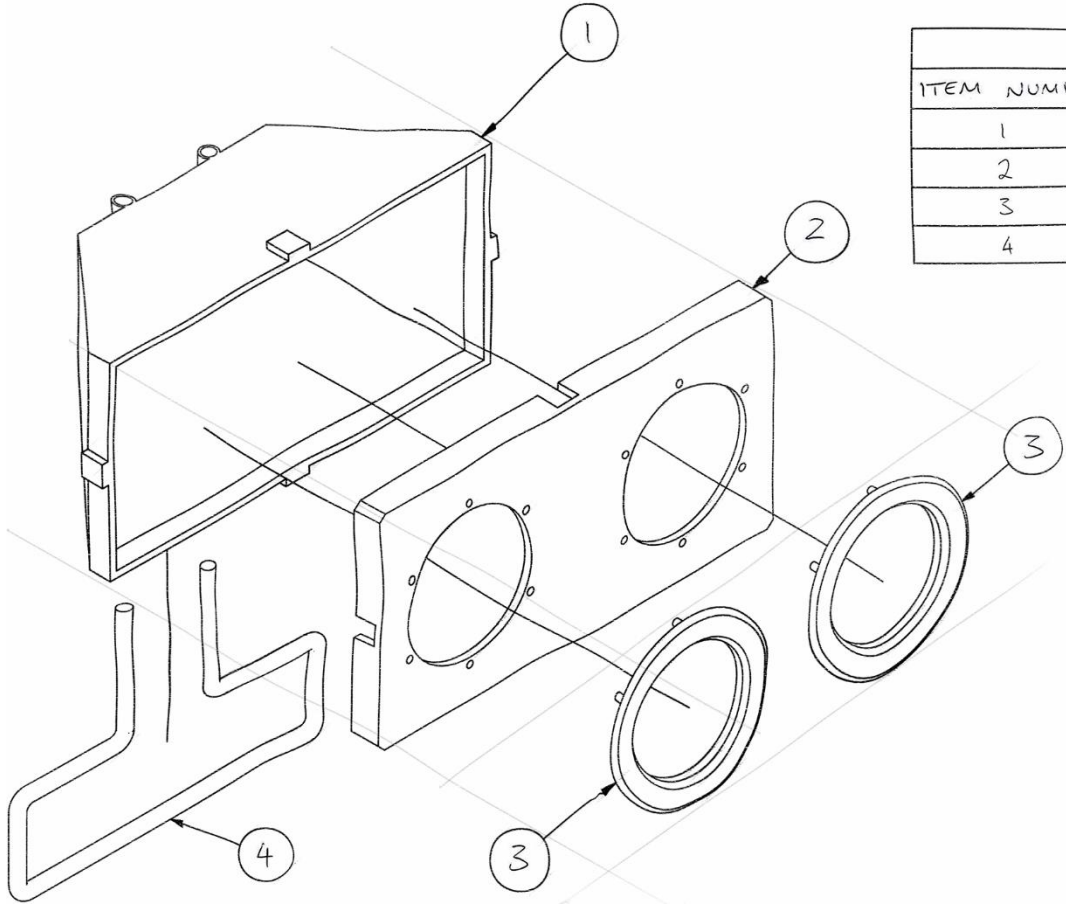

PARTS LIST		
ITEM NUMBER	QUANTITY	COMPONENT
1	1	BACK CASING
2	1	FRONT CASING
3	2	SPEAKER DISC
4	1	STABILISING ROD

Data sheet 2 – sketches of speaker casing components – (part 1) back casing

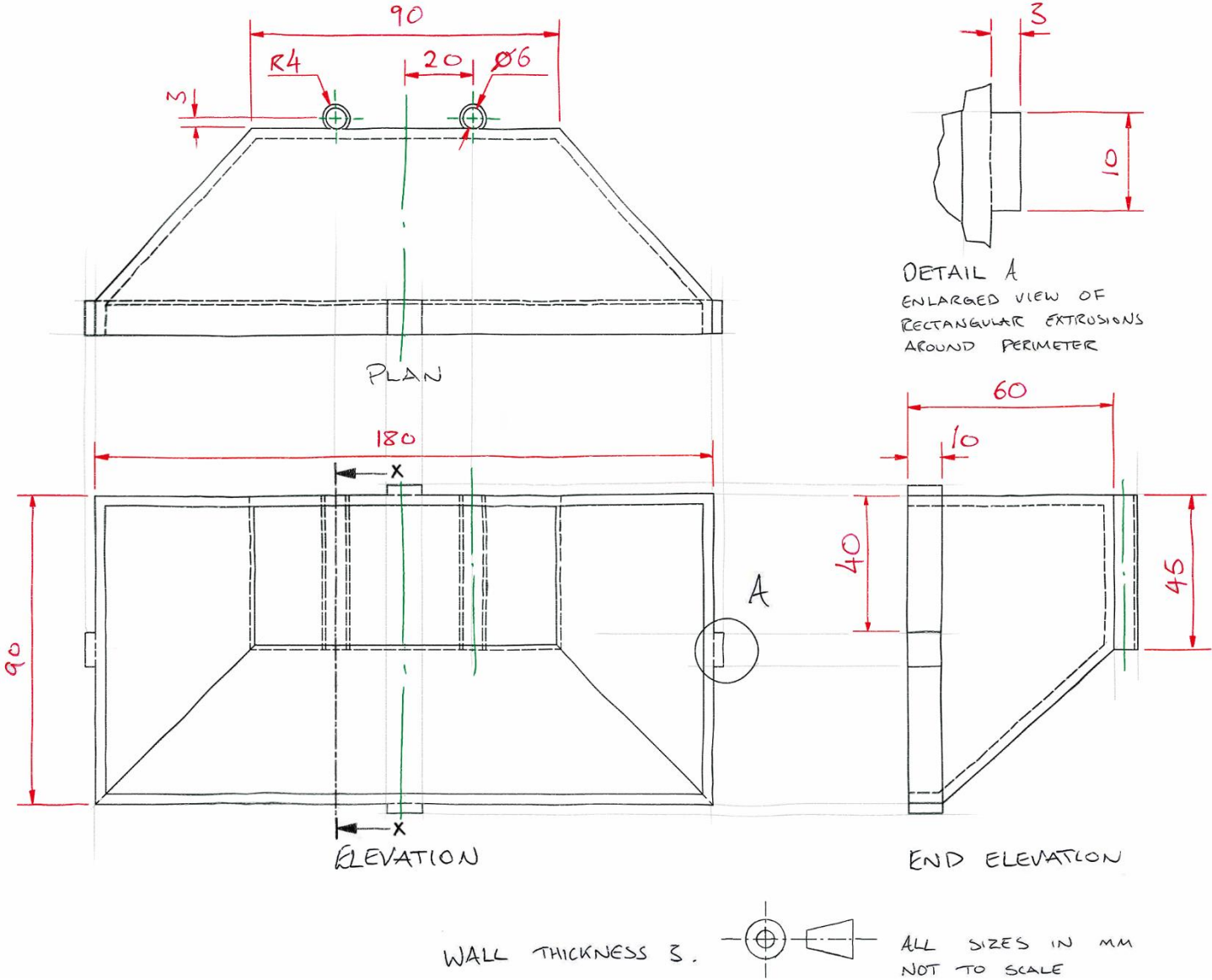

Data sheet 3 – sketches of speaker casing components – (part 2) front casing

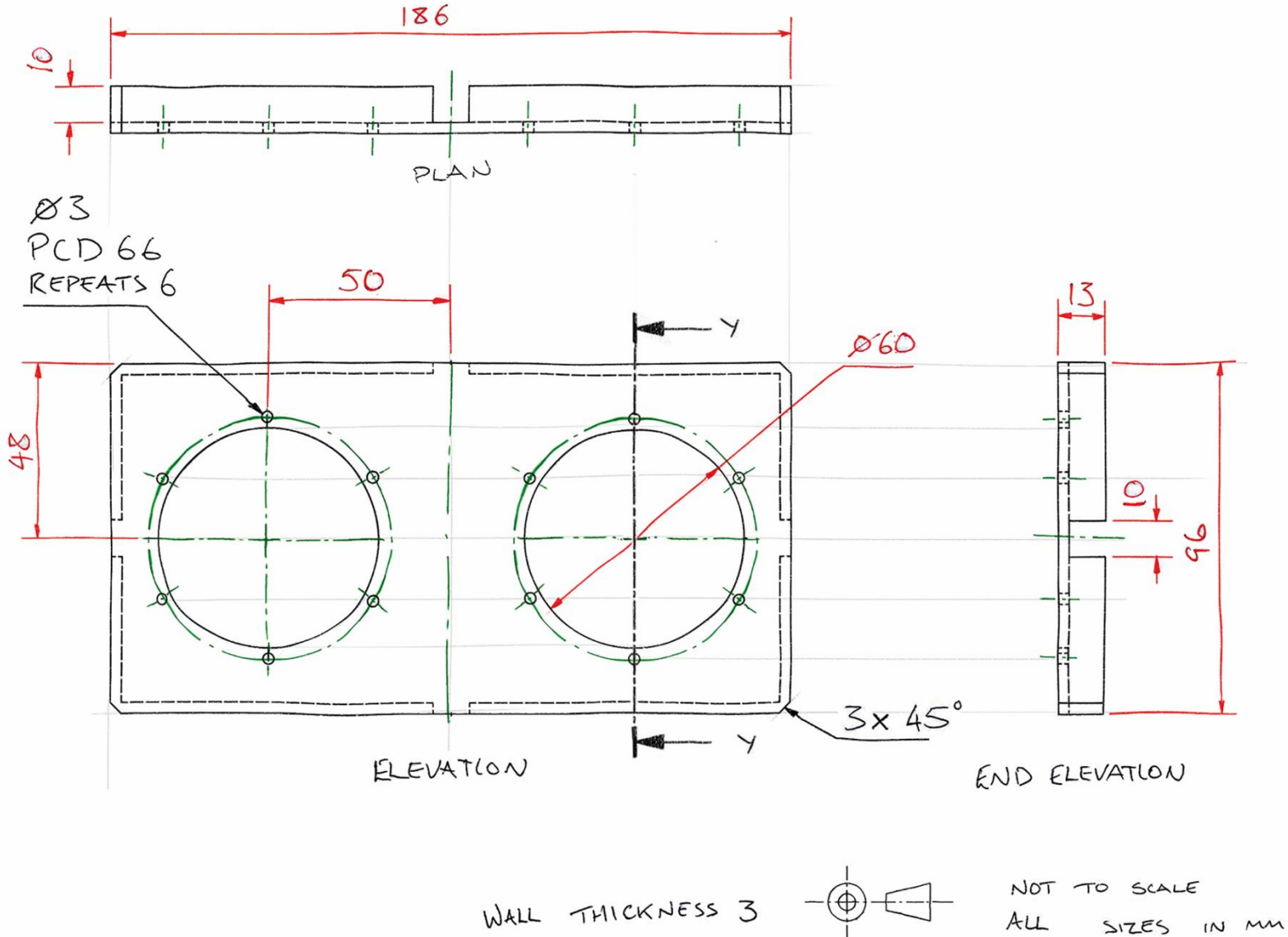

Data sheet 4 – sketches of speaker casing components – (part 3) speaker disc

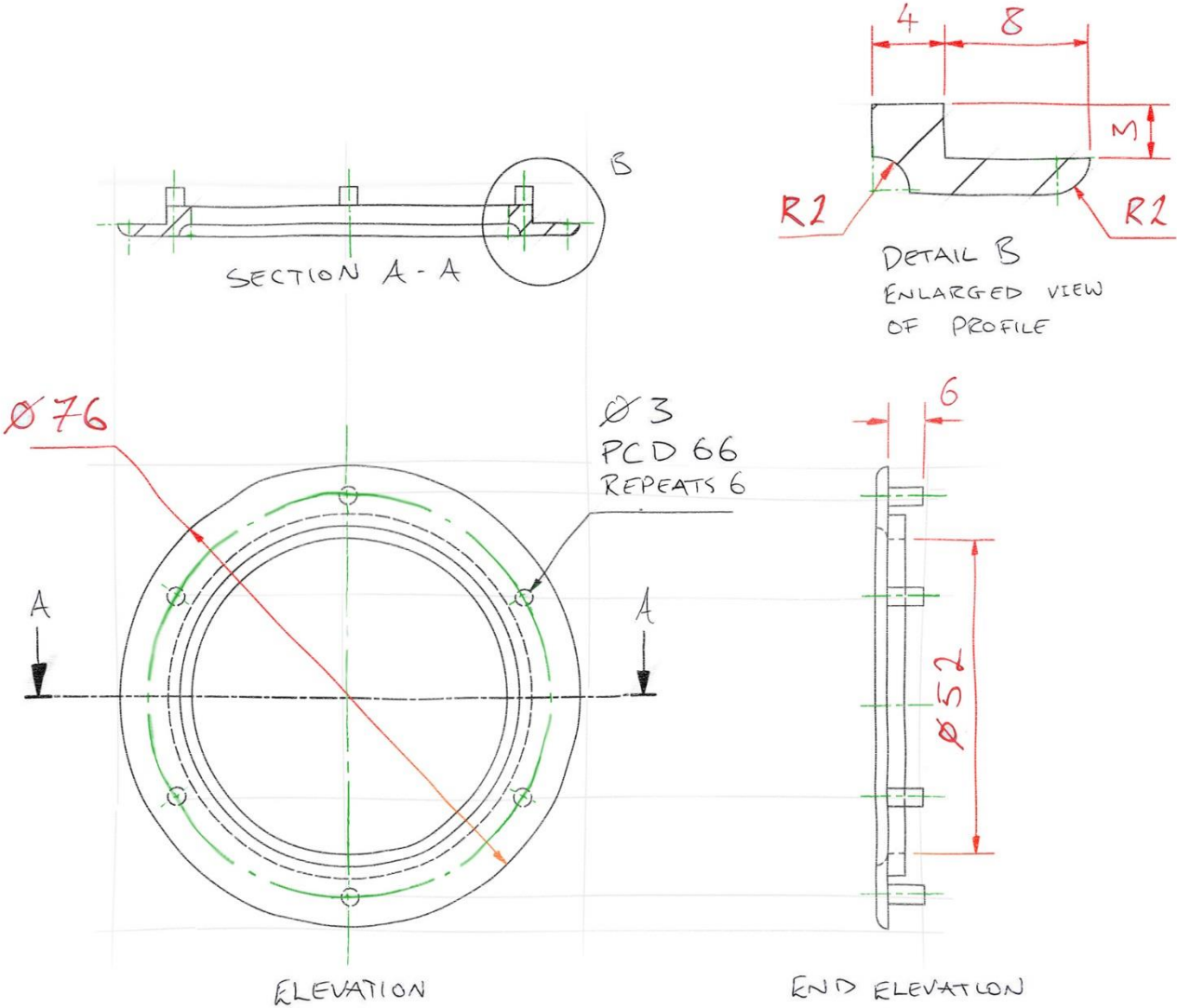

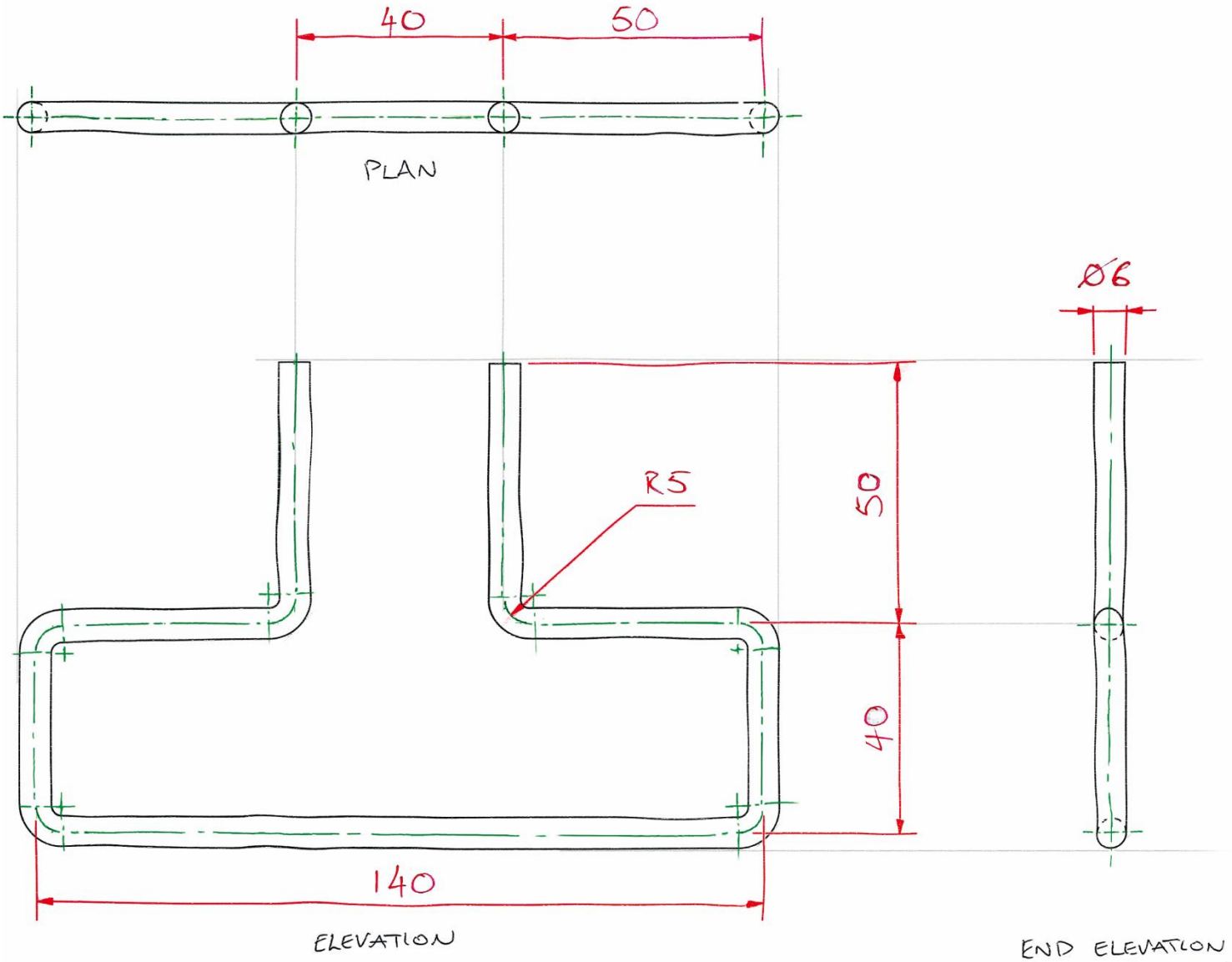

 ALL SIZES IN MM
 NOT TO SCALE

Data sheet 5 – sketches of speaker casing components – (part 4) stabilising rod

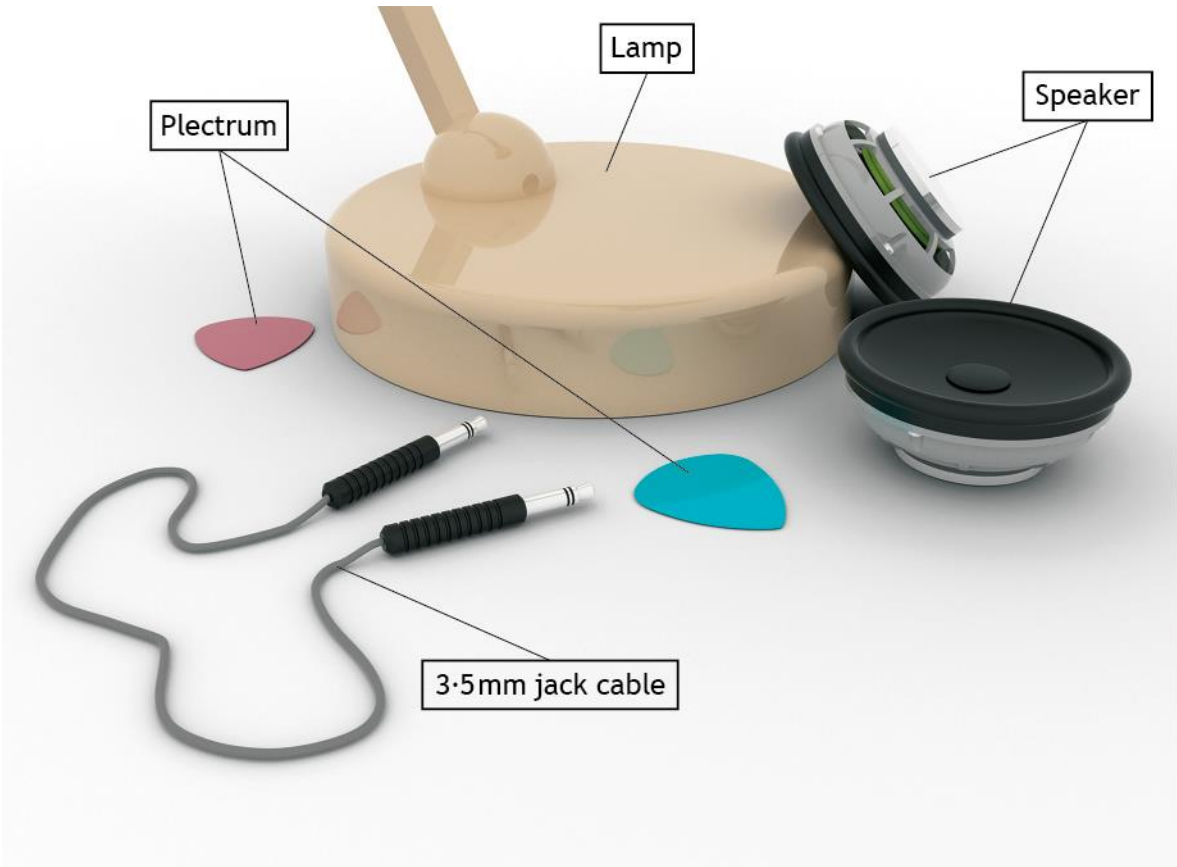

NOT TO SCALE
ALL SIZES IN MM

Data sheet 6 – illustrated examples of STEP files



Data sheet 7 – logo, font, colour scheme and copy text

Copy text:

“The LWR Music portable wireless speaker remains lightweight, while still delivering a powerful and rich listening experience. The twin-speaker setup produces clean vocal sounds and boasts a powerful bass response.

Featuring a range of pre-set sound setups, the LWR Music portable wireless speaker can be customised to suit your every need; from house party music, to relaxation sounds. The compact nature of this speaker makes it an ideal product if you are on the move, or simply enjoy listening to your sounds in a variety of rooms and locations around your home.

The musician’s wingman – this portable speaker features electric and bass guitar connectivity. This allows you to connect your instrument (using our mobile phone app) directly to your speaker to use as a practice amplifier.

Visit our website www.lwrmusic.co.uk for more details on this product.”

Company name: LWR Music

Font: Century Gothic or Calibri



Logo: supplied as jpg file

Company colours:	Colour 1 C55	Colour 2 C25	Colour 3 C9
	M0	M74	M58
	Y8	Y0	Y92
	K0	K0	K1

Promotional item:

Folding leaflet with three panels:

1. Front
2. Back
3. Double panel spread

Back and front must be **200mm x 100mm**, with a fold directly in the centre (100mm from left edge).

Double panel spread must be **200mm x 100mm**.

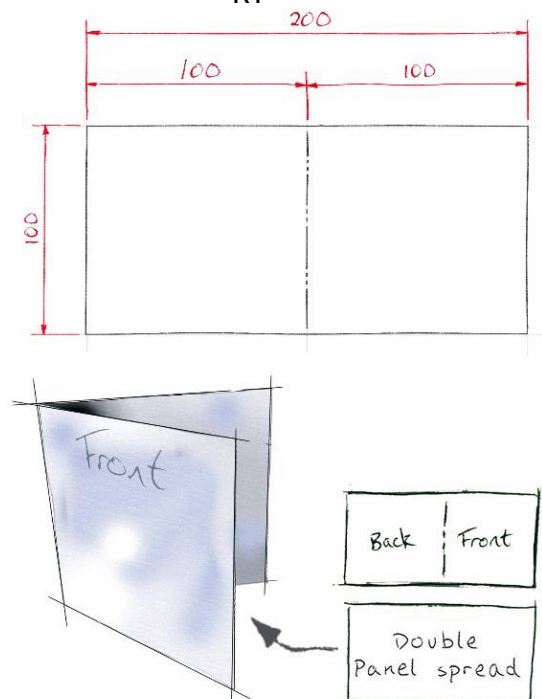

Data sheet 8 – promotional display item images



Data sheet 9 – sketches of luggage tag, font, colour scheme and copy text

Non-visible area highlighted in red can be used as a bleed area but must not contain text

copy text

Side 1 → www.LWRmusic.co.uk
 → The ultimate online music catalogue

Font: Century Gothic
 OR Calibri

Colour:

C55	C25	C9
M0	M74	M58
Y8	Y0	Y92
K0	K0	K1

Side 2 → Name:
 → Address:
 → TEL.:

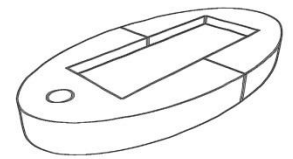

Pictorial

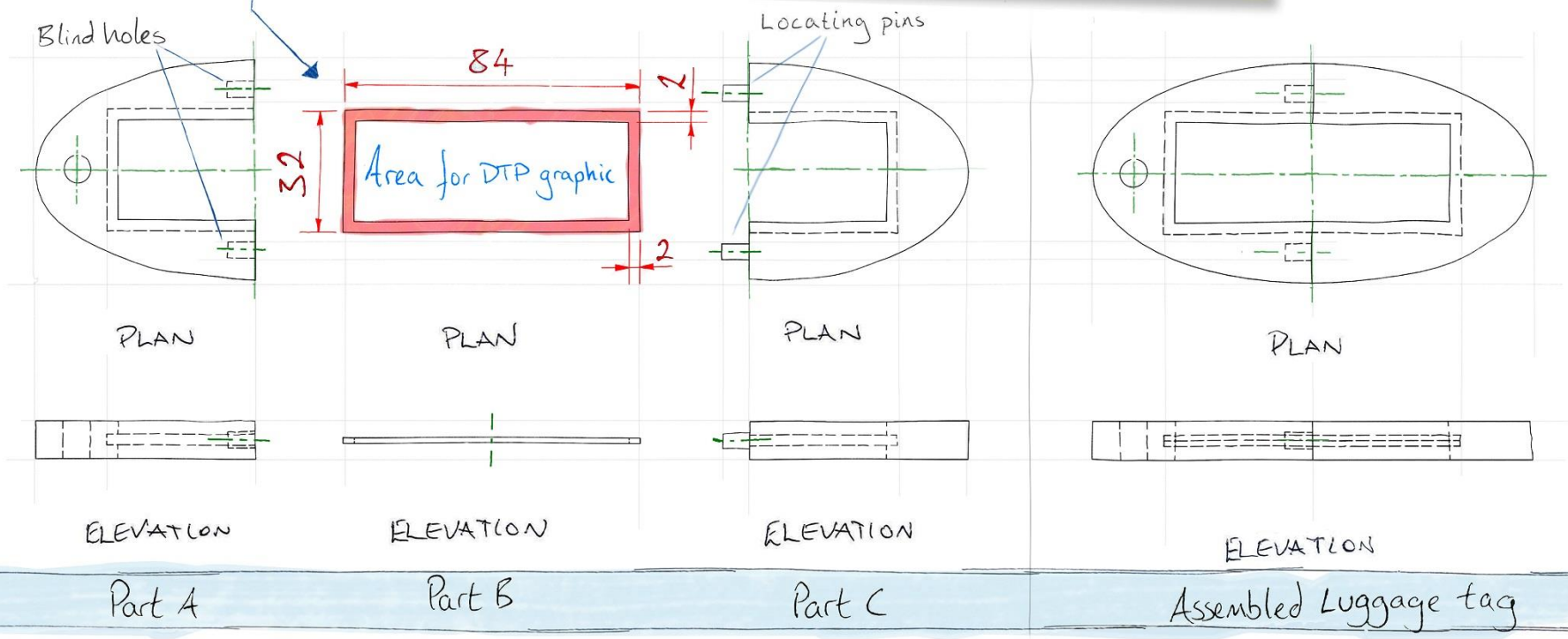

NOT TO SCALE
 ALL SIZES IN MM

Acknowledgement of copyright
All images copyright SQA.

Administrative information

Published: January 2019 (version 1.0)

History of changes

Version	Description of change	Date

Note: you are advised to check SQA's website to ensure you are using the most up-to-date version of this document.

Security and confidentiality

This document can be used by SQA approved centres for the assessment of National Courses and not for any other purpose.