



National
Qualifications
2019

2019 Graphic Communication

Higher

Finalised Marking Instructions

© Scottish Qualifications Authority 2019

These marking instructions have been prepared by examination teams for use by SQA appointed markers when marking external course assessments.

The information in this document may be reproduced in support of SQA qualifications only on a non-commercial basis. If it is reproduced, SQA must be clearly acknowledged as the source. If it is to be reproduced for any other purpose, written permission must be obtained from permissions@sqa.org.uk.



General marking principles for Higher Graphic Communication

Always apply these general principles. Use them in conjunction with the specific marking instructions, which identify the key features required in candidates' responses.

- (a) Always use positive marking. This means candidates accumulate marks for the demonstration of relevant skills, knowledge and understanding; marks are not deducted for errors or omissions.
- (b) If a candidate response does not seem to be covered by either the principles or detailed marking instructions, and you are uncertain how to assess it, you must seek guidance from your team leader.
- (c) For 'Describe' questions
Candidates must provide a statement or structure of characteristics and/or features, not just an outline or a list. For example they can refer to a concept, experiment, situation or facts in the context of and appropriate to the question. The number of marks available for a question indicates the number of factual/appropriate points required.
- (d) For 'Explain' questions
Candidates must relate cause and effect and/or define relationships. This must be in the context of the question, or a specific area within the question.
- (e) For 'Compare' questions
Candidates must demonstrate knowledge and understanding of the similarities and/or differences between things, methods, or choices. This must be in the context of the question, or a specific area within the question.
- (f) Candidates can respond to any question using text, sketching, annotations or combinations of these. Award marks for the information conveyed. Do not award marks for the quality of sketching.

Marking instructions for each question

Question			Expected response	Max mark	Additional guidance
1.	(a)		Application of <ul style="list-style-type: none"> • light • shadow • reflection • perspective • materials • textures • decals. 	2	Any two Do not accept one word answers, a description related to the model.
	(b)	(i)	<ul style="list-style-type: none"> • Create dia 105mm, 10mm thick cylinder (extruded, revolved or lofted). • Sketch dia 105mm circle, sketch square 50mm. • Workplane 110mm between dia 105 circle and 50 square. • Loft between dia 105mm circle and 50mm square. • Shell to 4mm wall thickness, remove bottom face. • Add ring to base, OD 113mm & ID97mm, extruded 4mm. Or loft between planes 4mm apart with OD113 & ID97 circles on both planes. 	6	1 mark for each bullet point Dia 105, 10mm and modelling technique for 1 mark. If shell has been applied to the bottom face after completion of the modelling do not award mark for the shell.

Question			Expected response	Max mark	Additional guidance
1.	(b)	(ii)	<ul style="list-style-type: none"> • Sketch centre axis and 14mm x 4mm rectangle in correct position and revolve around centre axis. • Vertical workplane mentioned or profile sketch is shown on an elevation. • Sketch R2 semi-circle 9mm from base (or 1mm from lip). • Revolve R2 semi-circle 30 degrees around centre axis. • Repeat sketch on other side and 30 degrees opposite direction. 	5	<p>1 mark for each bullet point</p> <p>48.5mm if taken to inside edge, 52.5mm if taken from outside edge or sketched to be in line with existing edge of lid.</p> <p>If mirroring feature a perpendicular work plane created at 15 degrees to centre line must be described/ sketched.</p> <p>The feature could also be created using a radial array.</p>
	(c)		<ul style="list-style-type: none"> • Centre Axis all three components. • Mate top surface of Blade One to underside of Pin head. • Offset 10mm between two correct surfaces (top or bottom). • Orientate at 120 degrees angle using angular constraint. 	4	<p>1 mark for each bullet point</p>

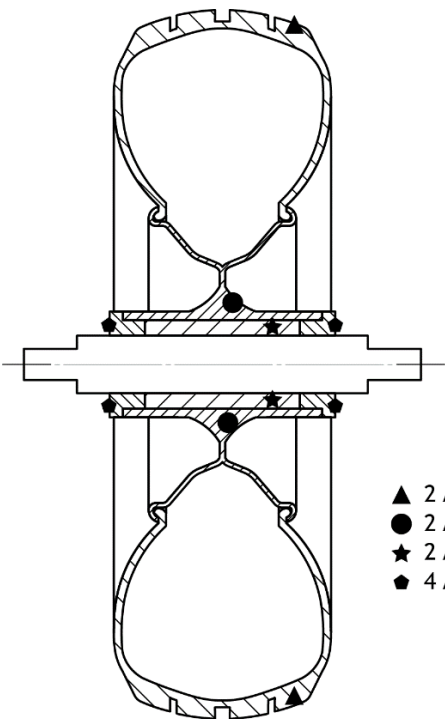
Question	Expected response	Max mark	Additional guidance
2.	 <p data-bbox="742 757 949 873"> ▲ 2 Areas - 1 mark ● 2 Areas - 1 mark ★ 2 Areas - 1 mark ◆ 4 Areas - 1 mark </p> <p data-bbox="406 1008 742 1041">ENLARGED SECTIONAL VIEW A-A</p>	4	<p data-bbox="973 224 1460 302">1 mark for each correctly sectioned component.</p> <p data-bbox="973 324 1460 403">No marks deducted for extra areas hatched</p> <p data-bbox="973 436 1460 548">Each component which has two areas hatched, the hatching style must match.</p> <p data-bbox="973 582 1460 694">Clear distinction between components should be reflected in the hatching style applied.</p>

Question			Expected response	Max mark	Additional guidance
3.	(a)	(i)	<ul style="list-style-type: none"> • Scalable without pixelation. • Easy to edit background colour, text colour, line colour in DTP software. • Transparency can easily be applied to background. • Vector graphics have a smaller file size than raster graphics. 	2	Any two
		(ii)	.svg (scalable vector graphic)	1	
		(iii)	<ul style="list-style-type: none"> • Improves corporate image of company. • Easier to enable remote working. • Easier to collaborate on projects remotely. • Reduced costs from storage. • Reduced costs from use of ink, toner or paper OR reduced environmental impact from use of ink or toner. 	2	Any two Candidates can only score a maximum of 1 mark for either, ink, toner or paper.
	(b)	(i)	<ul style="list-style-type: none"> • Separates graphic into different sections. • Separates text into different sections. • Aids clarity for reading. • Thin/narrow lines help to emphasise bold text. • Creates grid structure. 	2	Any two Description must indicate where line has been used in the given layouts.
		(ii)	<ul style="list-style-type: none"> • Alignment of text centered down R.H column. • Alignment of header with vertical line and name of pass holder. • Alignment of 'PRESS' and 'ARTIST' with camera, speaker silhouettes or triangle. • Blocks of colour fill are in alignment with each other. • Blocks of colour fill are in alignment with Scotrock Headline. 	2	Award a mark where the candidate has identified 2 features which are correctly aligned.

Question			Expected response	Max mark	Additional guidance
3.	(b)	(iii)	<p>Asymmetrical balance creates movement from left to right across the page.</p> <p>OR</p> <p>Asymmetrical balance creates visual interest.</p>	2	<p>Answer must state 'Asymmetrical balance' and justification of how it is used.</p> <p>1 mark for 'Asymmetrical balance'.</p> <p>1 mark for explanation of how it is used.</p>
		(iv)	<ul style="list-style-type: none"> • Contrast with serif/sans serif/script typefaces. • Contrast between large/bold and small typefaces. • Reverse effect with text creates contrast. • Square shapes/straight lines contrast with circle in header. • Contrast between central justification of text and right justification. • Contrast between vertical and horizontal text. • Contrast between vertical and horizontal lines. 	2	Any two

Question			Expected response	Max mark	Additional guidance
3.	(c)	(i)	<ul style="list-style-type: none"> • Can show DTP work in realistic setting. • To give an idea of the ease of readability/clarity in a sited environment. • No need to print full-size samples. • Gives clients an idea of scale. • Different conditions can be shown ie how publications look in light/dark rooms or in sunny/dark conditions. 	2	Any two
		(ii)	<ul style="list-style-type: none"> • Changes can be made without the need for reprinting. • Scrolling screens can be added allowing more information or advertisements to be shown. • Live information can be added eg bus arrival/departure boards or live pricing on advertisements. • Moving images/video can be added. 	3	Any three No marks to be awarded for answers which do not relate to the advantages of the digital screen eg paper costs, printing costs etc.
	(d)	(i)	<ul style="list-style-type: none"> • Metal texture on publication creates visual interest on document. • Metal texture on publication creates contrast with the plain white background. • The texture gives a 3D effect with the ridges. • Metal texture on publication links with festival theme via links to industrial music/metal music/ links with metal structures at festival. 	2	Any two
		(ii)	<ul style="list-style-type: none"> • Drop shadows give impression of depth. • Layering of elements gives the impression of depth. • Perspective in image gives impression of depth. 	2	Any two Candidates must identify where the drop shadow/layering have been used for bullets 1 and 2.

Question			Expected response	Max mark	Additional guidance
3.	(d)	(iii)	<ul style="list-style-type: none"> • Reverse effect/coloured boxes emphasises text. • Scale/proportion of ‘Scotrock’ header creates emphasis. Eye is drawn to it as it is the largest element on the page. • White outline/glow on SCOTROCK logo. • Colour in image at top and ‘you are here’ box create emphasis. • Drop shadows behind rectangular shapes creates emphasis. • Layering of elements creates emphasis. • Website address in colour creates emphasis. • Capitalized and larger bolder font creates emphasis. 	2	Any two
		(iv)	Unity created by: <ul style="list-style-type: none"> • Repetition of colour throughout. • Repetition of typefaces (header & body text). • Rectangles containing headers overlapping shapes. • Repetition of triangular shapes throughout. • Repetition of the metallic texture at the top and bottom. 	2	Any two
		(v)	<ul style="list-style-type: none"> • Vertical columns created within document to separate information for clarity. • To separate information horizontally. (Music Festival, Bronze Silver, Gold packages and shuttle bus services) • The table at the bottom separates information for clarity. 	2	Any two

Question		Expected response	Max mark	Additional guidance
	(vi)	<ul style="list-style-type: none"> • Text and images can be edited separately. • Layers can be turned on and off to improve clarity during the production of the layout. • The layers can provide a master-page for similar future layouts. • Edit layers without effecting other parts of the layout. • Layers can be reordered, moved to front, moved to back. • Layers can be locked to stop them being edited or moved by mistake. 	2	Any two

Question		Expected response	Max mark	Additional guidance
4.	(a)	<ul style="list-style-type: none"> Diameter/radius of profile 2.5mm, from axis @ 8.75mm. Length of spring @ 50mm or 5 revolutions of profile, pitch 10mm. Feature as a helix. 	3	<p>1 mark for each bullet point</p> <p>Do not accept coil, spring</p>
	(b)	<p>Top (4)</p> <ul style="list-style-type: none"> Creation of top as shown in detail view B with relevant dimensions. Centre plane, circle profile 5mm, extrude subtract through part. Creation of slot 5 x dia 16 x 20mm. Top edges chamfer 2mm. <p>Bottom (2)</p> <ul style="list-style-type: none"> Path and profile with dimensions. Extrude/sweep along a path. 	6	<p>Top can also be made through lofting.</p> <p>1 mark for each bullet point</p> <p>If revolved centre axis and correct profile dimensions. If lofted correct profiles and offset workplanes. If extruded correct dimensions and taper angle 10 degrees.</p> <p>Candidate must make reference to the correct modelling technique eg extrude subtract when removing material</p>

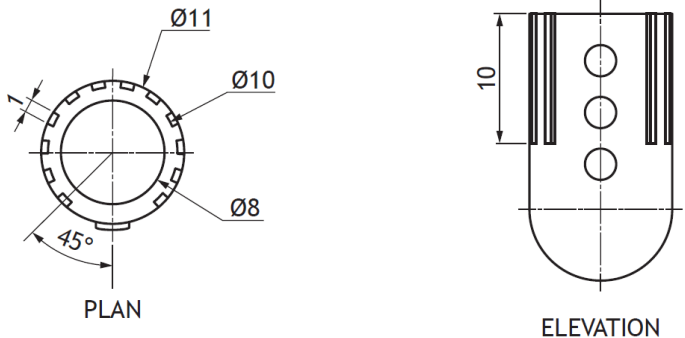
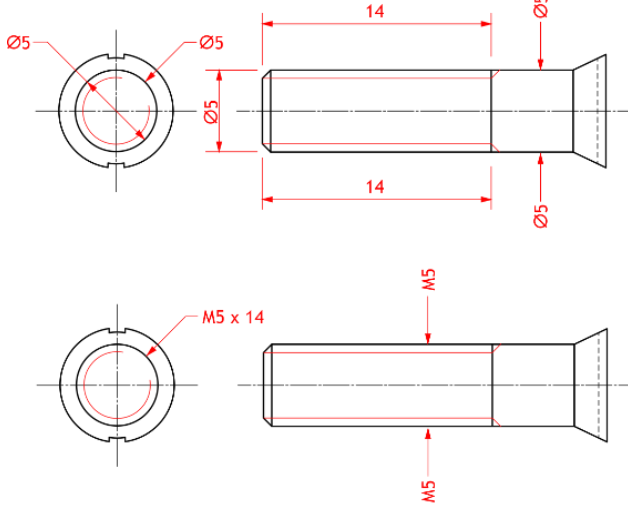
Question	Expected response	Max mark	Additional guidance
4. (c)	 <ul style="list-style-type: none"> • Draw profile with correct dimensions. • Extrude subtract profile 10mm. • Radial Array 12 times over 270 degrees. 	3	<p>1 mark for each bullet point</p> <p>Must be curved top and bottom to dia 10 and dia 11mm.</p> <p>Accept 11 plus original profile sketch.</p>
(d)		<p>(i) 1</p> <p>(ii) 1</p> <p>(iii) 2</p>	<p>(i) Diameter 5mm or M5, position and arrows to BS.</p> <p>(ii) Correct length, position, arrows, projection lines and gaps to BS.</p> <p>(iii) Correct BS thread convention on</p> <ul style="list-style-type: none"> • elevation (1 mark) • end elevation (1 mark) ignore thread runout.

Question		Expected response	Max mark	Additional guidance
	(e)	<ul style="list-style-type: none"> • Projection symbol. • Measurements in inches. • Dimensioning through leader lines. • Dimension orientation. • Centre line on hole wrong linetype. • Ends of cutting plane should go from short dash to thick long dash. • Inconsistent projection line gap. 	5	Any five

Question		Expected response	Max mark	Additional guidance
5.	(a)	<p>Figure 1 - Production graphic</p> <ul style="list-style-type: none"> • Technical details which allow construction of the building. <p>Figure 2 - Promotional graphic</p> <ul style="list-style-type: none"> • Promotion or advertising for the festival. • A simplistic map for use of non-specialist persons. • Clear details of all site amenities. <p>Figure 3 - Preliminary Graphic</p> <ul style="list-style-type: none"> • Gives a sense of scale of site on OS map. • No specific information can be gained. • Used to give a sense of how the site will be divided. 	3	<p>Must include the relevant 3P and mention the building and not a generic product.</p> <p>Must include the relevant 3P and relate to the festival graphic and not generic features of a promotional item.</p> <p>Must include the relevant 3P and relate to the preliminary map and not generic features of a preliminary item.</p>
	(b)	<ul style="list-style-type: none"> • North sign. • Contour lines. • Scale. • Roads/streets/street names • Boundary lines. • Geographical features, woodland, rivers. • Buildings. • Location of buildings. 	3	Any three
	(c)	<ul style="list-style-type: none"> • Contour lines close together, hilly area not suitable for camping. • Too many people in one area. • Camping area closer to entrance. • Easier access for disabled access. • Closer to entertainment. • Closer to amenities. 	2	<p>Any two</p> <p>For amenities candidates can state more than one eg charging point, Wi-Fi, drinking water and achieve 1 mark for each point.</p>
	(d)	5	1	
	(e)	<ul style="list-style-type: none"> • Access to build the site. • Access in/out of the buildings. 	1	

Question		Expected response	Max mark	Additional guidance
5.	(f)	<ul style="list-style-type: none"> Built around the existing natural environment. Replaced the number of trees that they have removed. Used reclaimed timber on the decked area. Removed trees could have been used to build the cabins. 	2	Any two
	(g)	<ul style="list-style-type: none"> Size of building. Size of paper. Amount of detail being shown. 	2	Any two Do not accept size of object, product, must state building for first bullet
	(h)	<ul style="list-style-type: none"> Multi-platform compatibility eg iOS, Android, PC. Compatible with different screen sizes and aspect ratios. Can increase scale without loss of clarity. Image contrast high for clarity. File size for download speed accessibility. Colour contrast. 	2	Any two
	(i)	<ul style="list-style-type: none"> Promoting event to a wider audience. Promoting 'their' product outwith the festival. Free advertising. Positive company image. Communication for family friends - safety. Ability to upload images - promotion. Ability to stream live feeds of the event. Potential advertising of products to users accessing the site. To gain more profit through ticket sales or advertising. 	2	Any two

[END OF MARKING INSTRUCTIONS]