

FOR OFFICIAL USE



National
Qualifications
2021 ASSESSMENT RESOURCE

Mark

X835/76/01

Graphic Communication

Duration — 2 hours



Fill in these boxes and read what is printed below.

Full name of centre

Town

Forename(s)

Surname

Number of seat

Date of birth

Day

Month

Year

Scottish candidate number

Total marks — 75

Attempt ALL questions.

All dimensions are in mm.

All technical sketches and drawings use third angle projection.

You may use rulers, compasses or trammels for measuring.

In all questions you may use sketches and annotations to support your answer if you wish.

Write your answers clearly in the spaces provided in this booklet. Additional space for answers is provided at the end of this booklet. If you use this space you must clearly identify the question number you are attempting.

Use **blue** or **black** ink.

Before leaving the examination room you must give this booklet to the Invigilator; if you do not, you may lose all the marks for this paper.



Total marks — 75
Attempt ALL questions

DO NOT
WRITE IN
THIS
MARGIN

1. Graphics of a vanity mirror are shown below.



Figure A

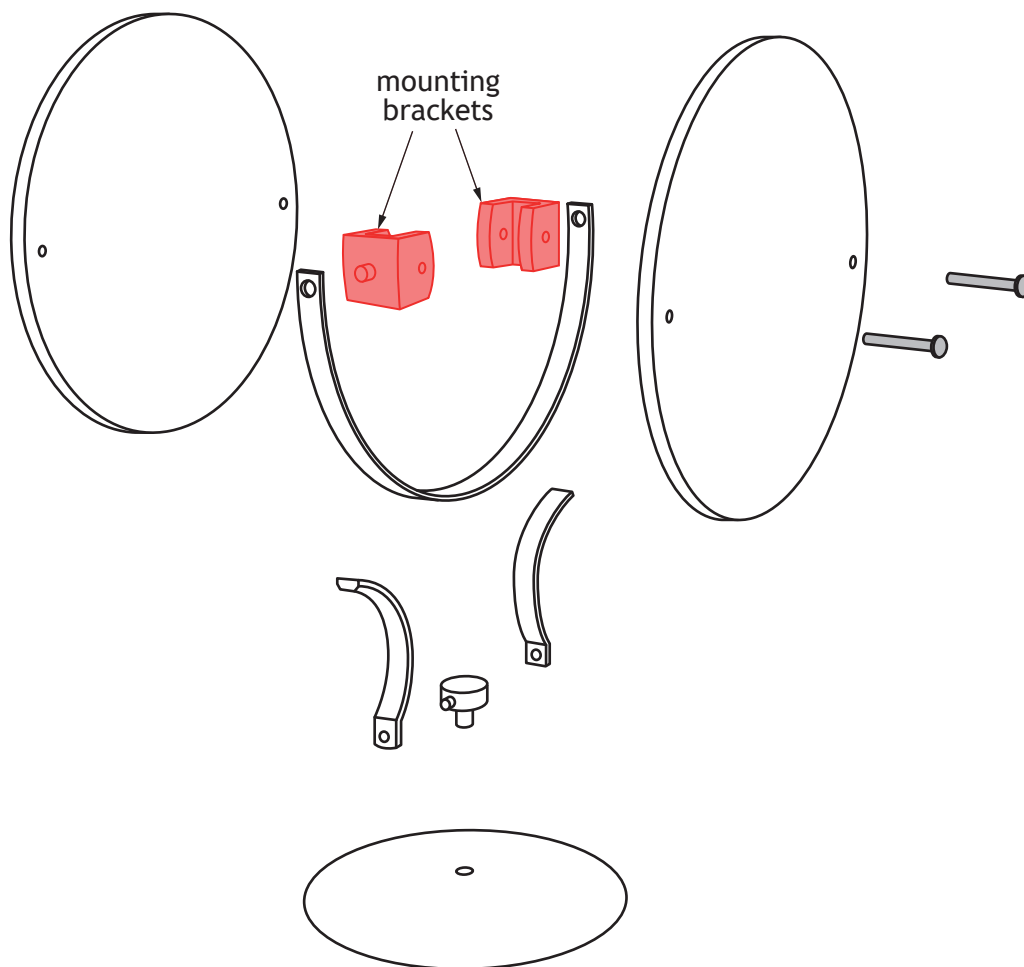

Figure B



* X 8 3 5 7 6 0 1 0 2 *

1. (continued)

MARKS
DO NOT
WRITE IN
THIS
MARGIN

- (a) (i) Describe the 3D CAD modelling techniques used to create the **mounting bracket** components, shown in **Figure B**.

4

You must use the additional information and dimensions provided on **supplementary sheets 1 and 2** to answer this question.

You may use sketches to support your answer.

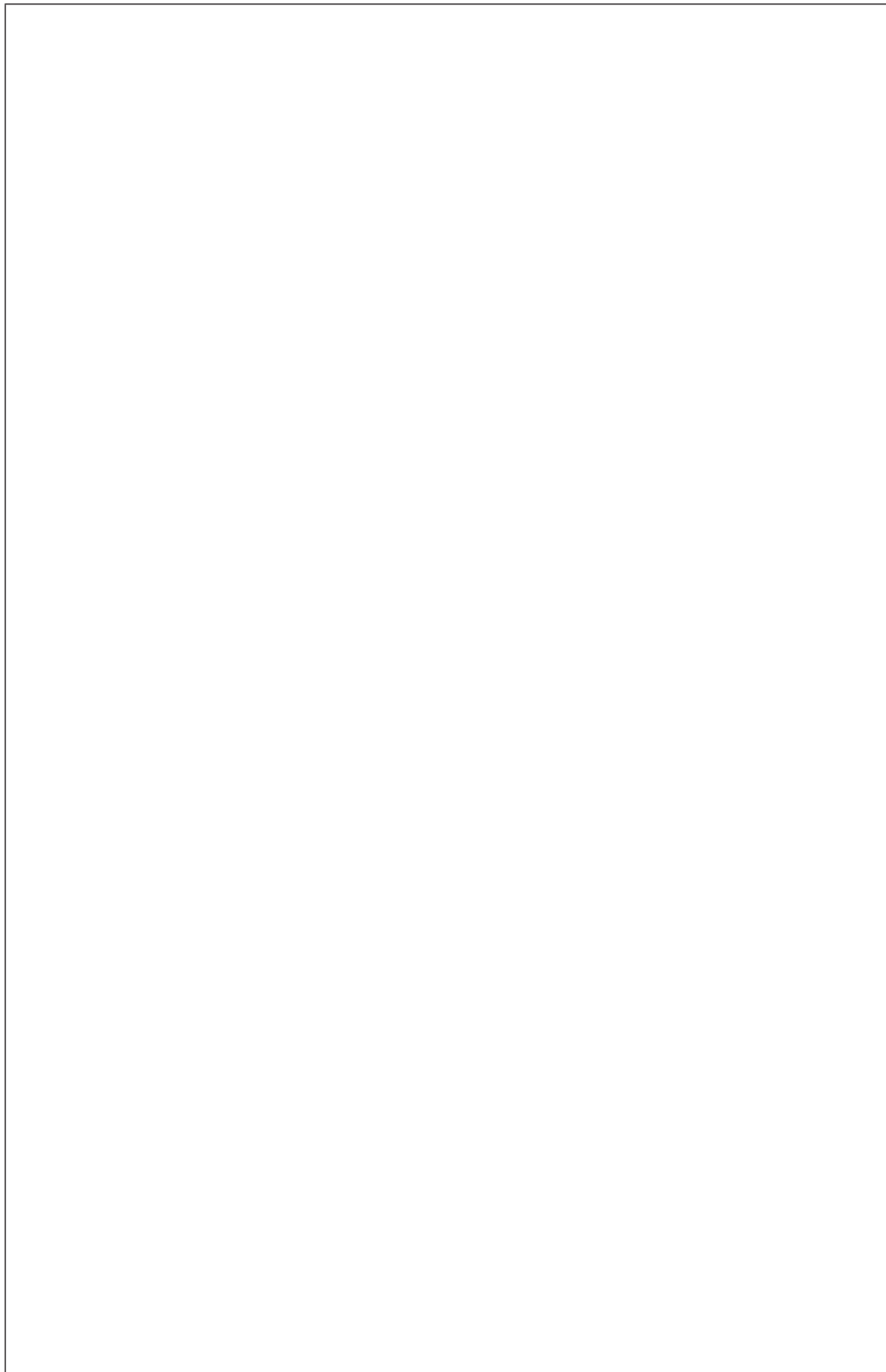

* X 8 3 5 7 6 0 1 0 3 *

1. (a) (continued)

You must use the additional information provided on **supplementary sheets 1 and 2** to answer this question.

- (ii) State the sizes of the missing dimensions **X**, **Y** and **Z** shown on the **Assembled Orthographic** views on **supplementary sheet 1**.

3

Dimension X _____ mm

Dimension Y _____ mm

Dimension Z _____ mm



* X 8 3 5 7 6 0 1 0 4 *

1. (continued)

MARKS
DO NOT
WRITE IN
THIS
MARGIN

3

- (b) Describe, using 3D CAD terms, how to assemble and constrain the mounting bracket onto the frame so that the mirror will sit in the vertical position.

You may annotate the illustration and use sketches to support your answer.

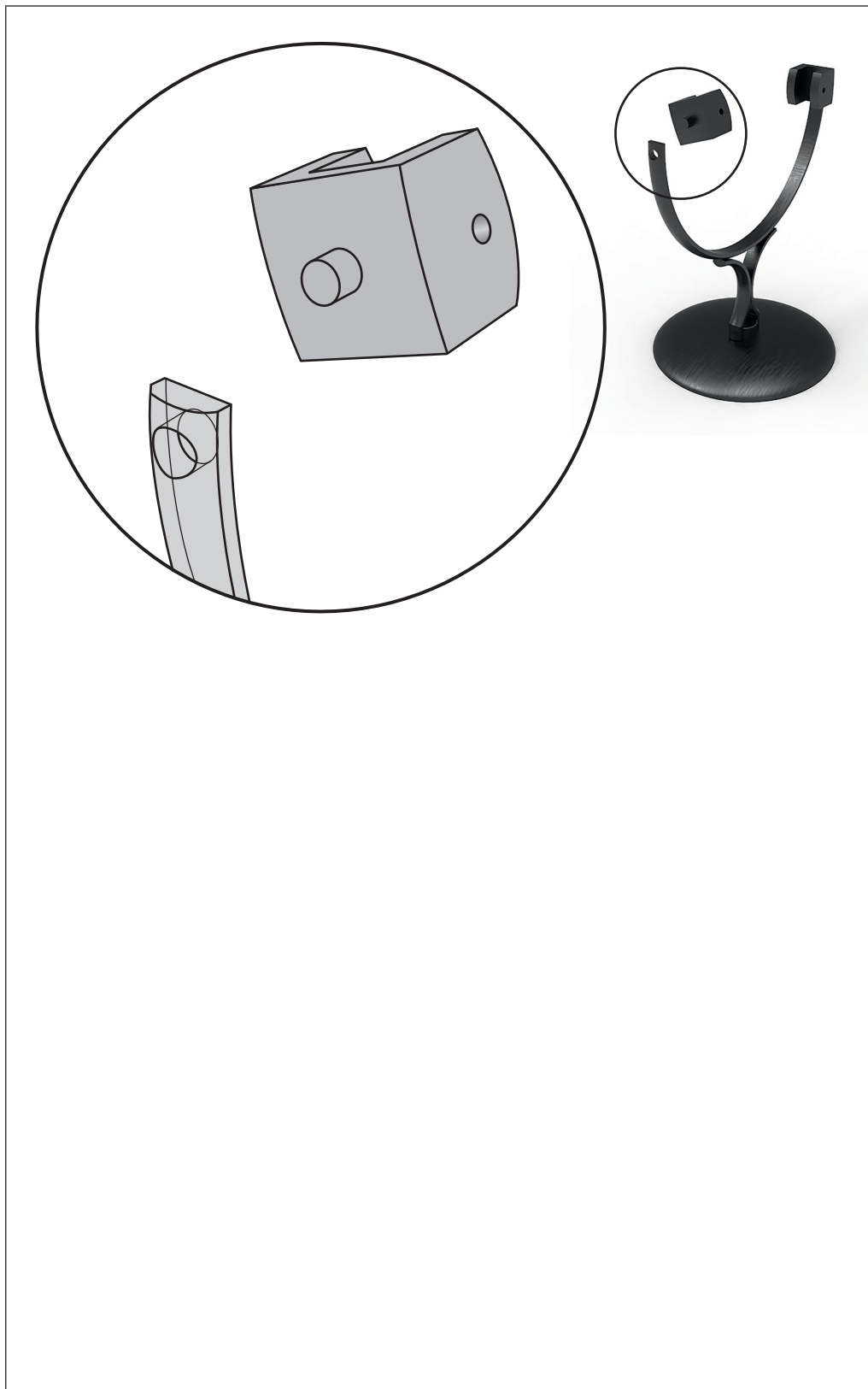

2. You must use the additional information provided on **supplementary sheets 3 and 4** to answer this question.

Information for the support arm component of a cutlery holder is shown below.

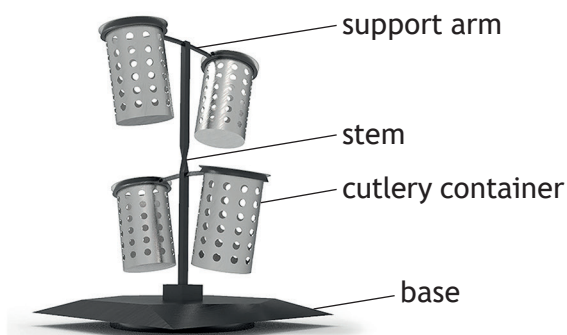

Figure C

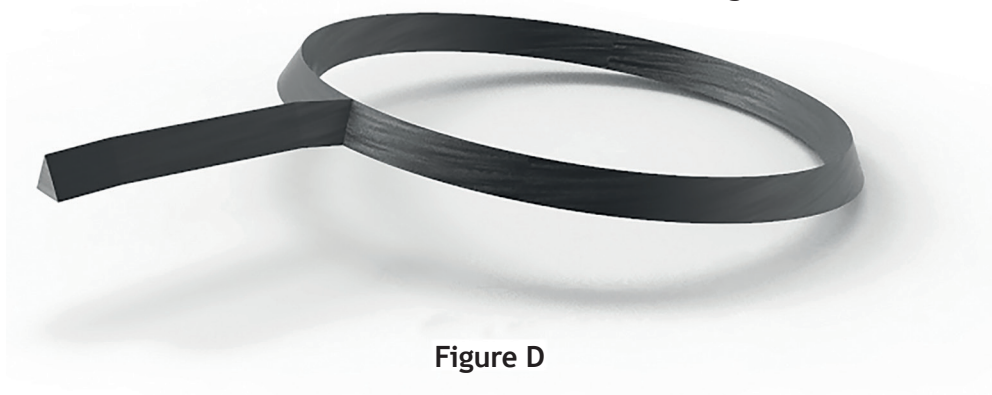
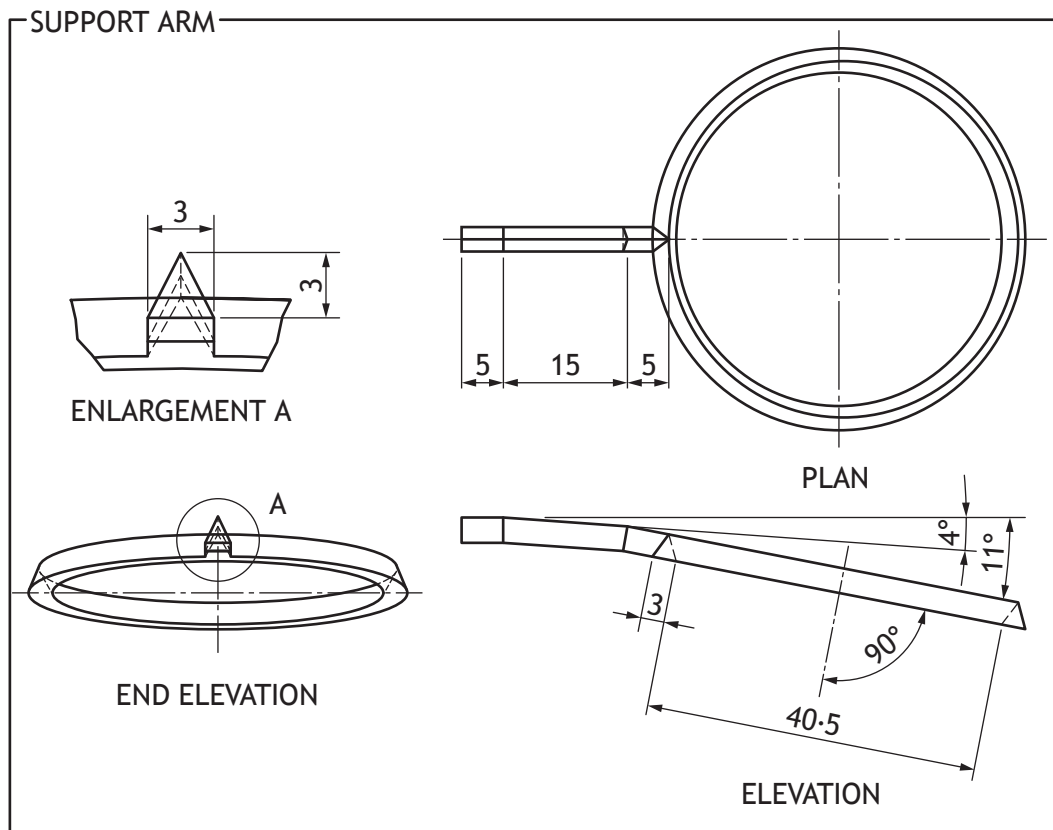

Figure D



2. (continued)

MARKS
DO NOT
WRITE IN
THIS
MARGIN

- (a) Describe the 3D CAD modelling techniques used to create the **support arm** component, shown in **Figure D** on the opposite page.
You must make reference to the dimensions shown on the opposite page.
You may use sketches to support your answer.

4



2. (continued)

MARKS
DO NOT
WRITE IN
THIS
MARGIN

An illustration of the **stem** component with twist is provided below in **Figure E**.

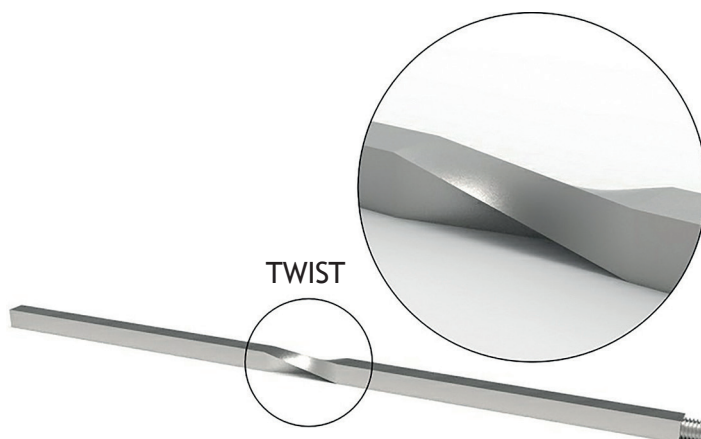

Figure E

- (b) Describe the 3D CAD modelling techniques used to create the **stem** component with twist, shown above in **Figure E**.

3

You must use the information and dimensions on **supplementary sheet 4** to answer this question.

You may use sketches to support your answer.



[Turn over for next question

DO NOT WRITE ON THIS PAGE



* X 8 3 5 7 6 0 1 0 9 *

2. (continued)

DO NOT
WRITE IN
THIS
MARGIN

The cutlery container has been redesigned as shown below.

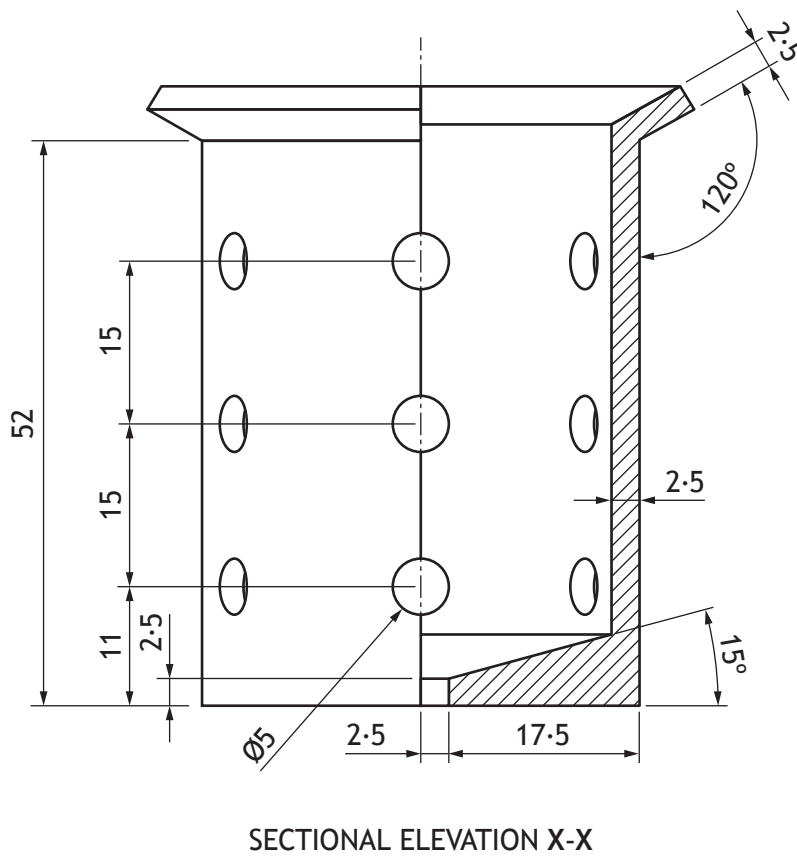
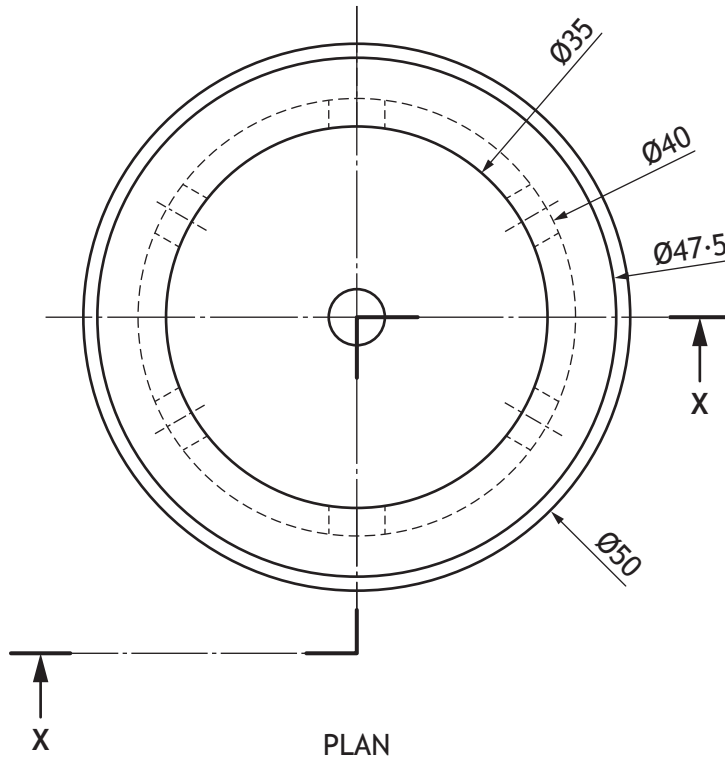

* X 8 3 5 7 6 0 1 1 0 *

2. (continued)

MARKS
DO NOT
WRITE IN
THIS
MARGIN

- (c) Describe the 3D CAD modelling techniques used to create the redesigned **cutlery container** component, shown on the opposite page.

4

You must make reference to the dimensions shown on the opposite page.

You may use sketches to support your answer.

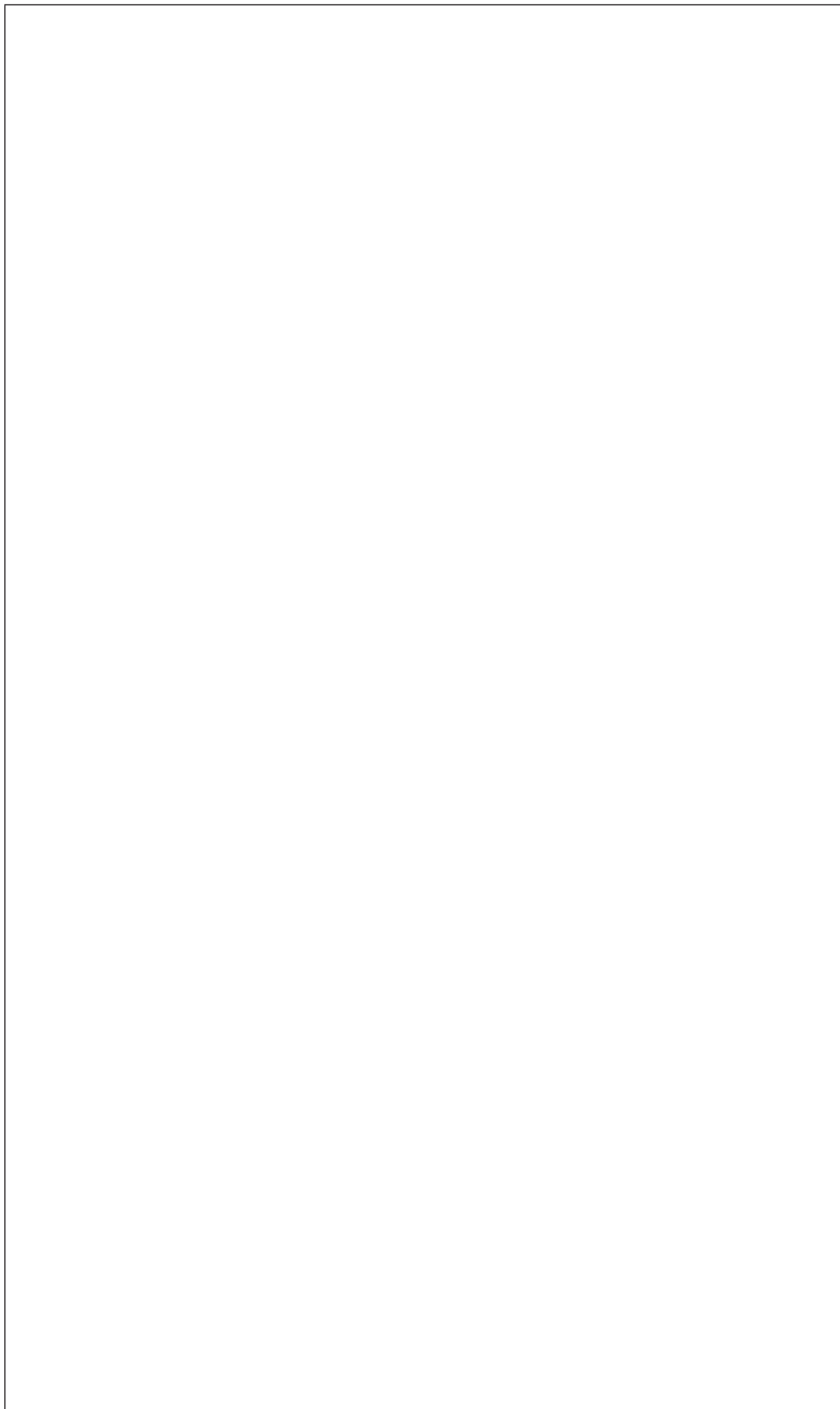

* X 8 3 5 7 6 0 1 1 1 *

3. A menu for a restaurant has been created by a graphic designer.
You must use the menu graphic provided on **supplementary sheet 5** to answer this question.

(a) (i) Describe two ways the designer has used **line** to enhance the layout of the graphic. 2

(ii) Describe two ways the designer has used **alignment** in the graphic. 2

(iii) Describe three ways the designer has created **contrast** in the graphic. 3

(iv) Describe two ways the designer has used **value** in the graphic. 2



* X 8 3 5 7 6 0 1 1 2 *

3. (a) (continued)

(v) Describe two ways the designer has used **unity** in the graphic.

2

(vi) Describe two ways the designer has used **grid structure** in the graphic.

2

[Turn over



* X 8 3 5 7 6 0 1 1 3 *

3. (continued)

MARKS
DO NOT
WRITE IN
THIS
MARGIN



logo

The logo from the menu graphic was produced in .dxf format.

- (b) Describe two advantages of using .dxf instead of .jpg as the format for the logo.

2



Part of the logo was created from a stock image with a watermark as shown above.

- (c) Explain, giving two reasons, why watermarks are added to the stock images.

2



4. A water park is planning an extension. A range of graphics have been produced for this as shown below.

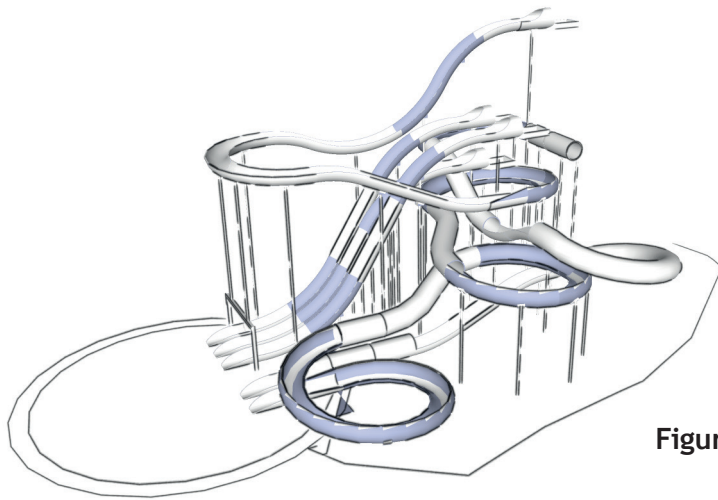

Figure 1

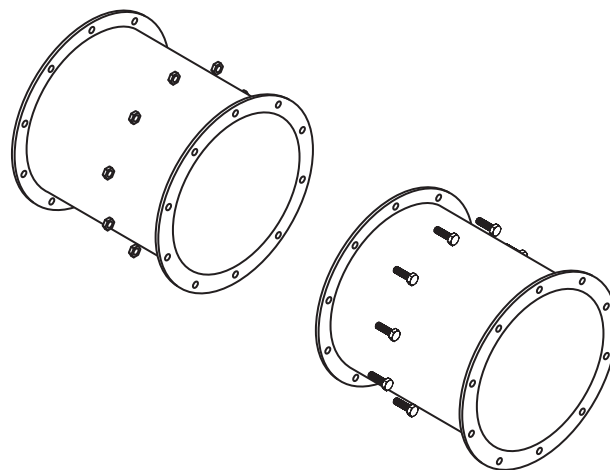

Figure 2

- (a) Explain with reference to preliminary, production and promotional graphics, the purpose of **Figure 1** and **Figure 2**.

Figure 1

1

- (i) _____

Figure 2

1

- (ii) _____



* X 8 3 5 7 6 0 1 1 5 *

4. (continued)

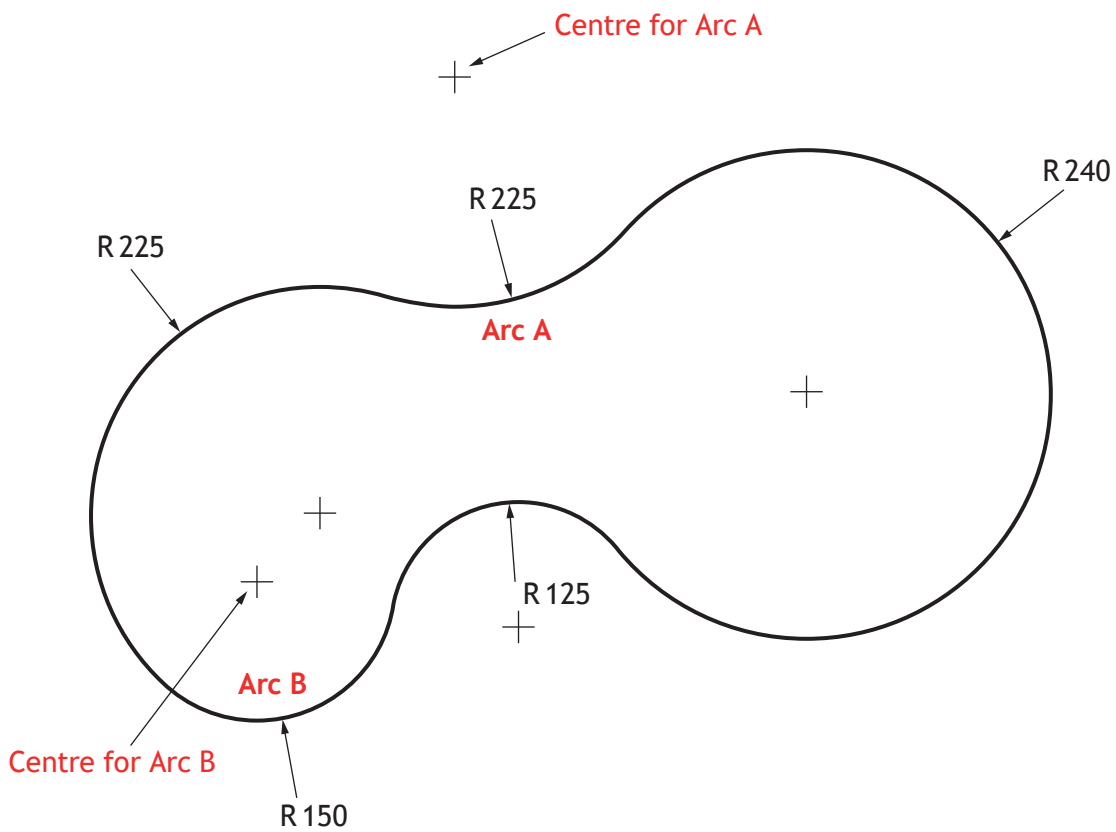

A new pool shape for the water park was constructed using tangency.

- (b) Calculate the two radii required to find the centre point for Arc A. 2

- (c) Calculate the two radii required to find the centre point for Arc B. 2



* X 8 3 5 7 6 0 1 1 6 *

4. (continued)

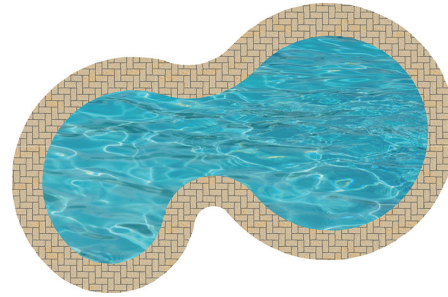
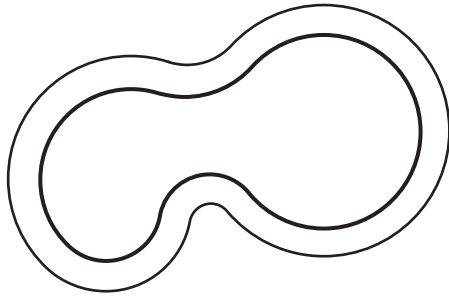

The designer wanted the pool edging to follow the same shape as the pool.

- (d) State the name of the 2D CAD tool used to ensure the pool edging was the same shape as the pool shown above.

1

A 3D CAD model can be used to aid manufacture.

- (e) Describe two benefits of using 3D CAD models in manufacture.

2

[Turn over



* X 8 3 5 7 6 0 1 1 7 *

4. (continued)

The water park will install a new double tower flume design.



- (f) Describe the 3D CAD modelling technique used to produce the section of the water flume shown below. Make reference to the dimensions given below. You may use sketches to support your answer.

3

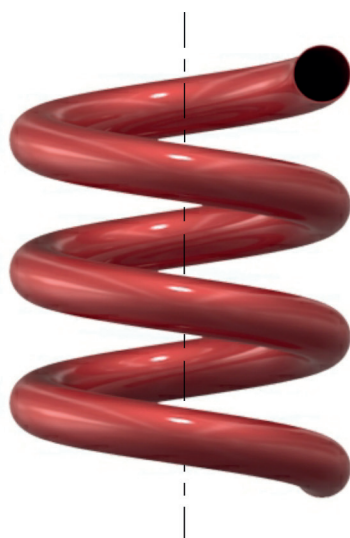

Flume profile diameter 900 mm
Thickness of material 20 mm
Flume diameter 4500 mm
Flume pitch 2250 mm

4. (continued)

- (g) The water flume designs were designed and assembled using a component part library. The 3D modelling files were saved in the STEP file format.

Name another suitable 3D modelling file format that could be used for manufacture.

1

- (h) Explain the 3D CAD term **bottom up modelling**, making reference to parts and assemblies.

2

- (i) The design team uses CAD software that makes use of cloud computing.

- (i) Describe two advantages that cloud computing can offer the design team for site visits.

2

- (ii) Describe two disadvantages of cloud storage for the design team.

2

[Turn over



* X 8 3 5 7 6 0 1 1 9 *

5. Two graphics showing the outside and inside of a brochure for the water park are shown below.

Graphic 1



Graphic 2



* X 8 3 5 7 6 0 1 2 0 *

5. (continued)

MARKS

DO NOT
WRITE IN
THIS
MARGIN

- (a) Explain why the designer's use of shape enhances the layout of **Graphic 1**.

3

- (b) Describe two ways the designer has used DTP techniques to create **depth** in the layouts.

2

- (c) Describe two ways the designer has used DTP features to introduce **proportion** in the layouts.

2

- (d) Describe three ways the designer has used **texture** to add context to the brochure.

3



* X 8 3 5 7 6 0 1 2 1 *

5. (continued)

(e) State the DTP edit applied to the text to follow the wave profile.

1



The company are aware of their corporate identity, and want to be socially and environmentally friendly.

(f) Describe how the company could reduce their carbon footprint, other than promoting and advertising their business online.

2



* X 8 3 5 7 6 0 1 2 2 *

5. (continued)

MARKS DO NOT WRITE IN THIS MARGIN

The brochure shown below is in prepress format.



(g) State the name of the prepress features shown at A and B. 2

Feature A _____

Feature B _____

(h) Explain why the features are important to the graphic designer and the print house. 2

Feature A _____

Feature B _____

(i) Identify where **bleed** has been used in the prepress brochure shown above. 1

[END OF QUESTION PAPER]



* X 8 3 5 7 6 0 1 2 3 *

MARKS

DO NOT
WRITE IN
THIS
MARGIN

ADDITIONAL SPACE FOR ANSWERS



* X 8 3 5 7 6 0 1 2 4 *

MARKS

DO NOT
WRITE IN
THIS
MARGIN

ADDITIONAL SPACE FOR ANSWERS



* X 8 3 5 7 6 0 1 2 5 *

[BLANK PAGE]

DO NOT WRITE ON THIS PAGE



* X 8 3 5 7 6 0 1 2 6 *

[BLANK PAGE]

DO NOT WRITE ON THIS PAGE



* X 8 3 5 7 6 0 1 2 7 *

[BLANK PAGE]

DO NOT WRITE ON THIS PAGE

Acknowledgement of copyright

Question 3 (b) file404/shutterstock.com

Question 4 Photograph of flume is taken from Aquarena. Reproduced by permission of Aquarena. ©
AQUARENA GmbH.

Question 5 Image of girls in sunglasses is taken from Pexels
Image of soccer ball in swimming pool is taken from Pexels
Image of flumes is taken from Pixabay

Question 5 Google maps and logo are taken from Google



* X 8 3 5 7 6 0 1 2 8 *