



Higher Graphic Communication Assignment Assessment task

This document provides information for teachers and lecturers about the coursework component of this course in terms of the skills, knowledge and understanding that are assessed. It must be read in conjunction with the course specification.

Valid for session 2021-22 only.

This assessment is given to centres in strictest confidence. You must keep it in a secure place until it is used.

This edition: December 2021 (version 1.0)

© Scottish Qualifications Authority 2021

Contents

Introduction	1
Instructions for teachers and lecturers	2
Instructions for candidates	6

Introduction

This document contains instructions for teachers and lecturers, and instructions for candidates for the Higher Graphic Communication assignment. You must read it in conjunction with the course specification.

This assignment has 50 marks out of a total of 125 marks available for the course assessment.

This is one of two course assessment components. The other component is a question paper.

Instructions for teachers and lecturers

You must conduct the assignment under a high degree of supervision and control. This means:

- ◆ candidates must be within your direct sight
- ◆ candidates must not interact with each other
- ◆ candidates must not have access to e-mail, the internet and mobile phones
- ◆ candidates must complete their work independently – no group work is permitted
- ◆ classroom display materials that might provide assistance must be removed or covered
- ◆ with no interruption for learning and teaching
- ◆ in a classroom environment

For session 2021-22 there is an additional point of guidance about assessment conditions. If a centre is temporarily closed or if candidates are isolating, they can work on the assignment from home. Where possible, you should adhere to the published conditions of assessment to maintain the reliability and validity of the evidence generated.

Time

Candidates have 8 hours to complete the assignment, starting at an appropriate point in the course after all content has been delivered. Once candidates begin, they must continue in each subsequent class period until the permitted time allocation has been used up.

You have a responsibility to manage candidates' work, distributing it at the beginning and collecting it at the end of each session, and storing it securely in between. This activity does not count towards the total time permitted for candidates to complete the assignment.

For session 2021-22 there is an additional point of guidance about time. Candidates can spend additional time on the assignment if necessary – for example, if a centre is temporarily closed. You should use your professional judgement to decide if additional time is necessary, as the assignment is designed to be completed in 8 hours. Spending more time on it could affect candidates' ability to cover all the learning required for the course and prepare for the question paper.

Resources

This is a closed-book assessment. Candidates must not have access to learning and teaching materials, the internet, notes, exemplar materials, resources on classroom walls or anything similar.

There may be instances where restriction of internet and/or network use is prohibited (for example, if you have a local authority-managed network with specific limitations or CAD software that is web-based). However, it remains your professional responsibility to make every effort to meet the assessment conditions.

Each assessment task includes instructions and details of any equipment or materials required. Candidates can also use normal classroom equipment, software and hardware (such as drawing instruments, CAD and DTP software, and PCs to run the software) to complete the tasks.

Candidates can use a pre-made or existing A3 CAD template.

Reasonable assistance

Candidates must progress through each stage of the assignment without your intervention or guidance, having acquired the skills earlier in the course.

Once candidates complete the assignment, you must not return it to them for further work. You must not provide feedback to candidates or offer an opinion on the perceived quality or completeness of the assignment response at any stage.

You can provide reasonable assistance to support candidates with the following aspects of their assignment:

- ◆ printing, collating, stapling and labelling their evidence to ensure it is in the format specified by SQA
- ◆ ensuring candidates have all the materials and equipment required to complete the assignment
- ◆ understanding the information outlined in these instructions

Evidence

All candidate evidence (whether created manually or electronically) must be submitted to SQA in a paper-based format.

Each task details what evidence is required and how many pages are expected. This is a guide to ensure that candidates do not produce too much work or spend too long on a single task. Single-sided A3 pages are preferred and are typically the most suitable for the tasks; however, it is acceptable to submit A4 pages if an A3 printer is not available.

Each piece of work must be labelled with the task number, for example task 3a, and the back of each page must be clearly labelled with candidate details.

Alteration or adaptation

You must not alter, adapt or modify the assignment in any way. This includes moving the content of the assignment into a different format or workbook. All candidates must undertake the assignment exactly as it is provided.

Volume

Candidates should present their work on a maximum of 10 single-sided A3-sized pages.

This figure is given to indicate the volume of evidence required; however, no penalty is applied where candidates exceed this. Full details of evidence requirements are contained within each assessment task.

Specific instructions for teachers and lecturers

You must follow these specific instructions. You must ensure that candidates are aware of the assessment conditions and know what they should do for each task.

Prior to candidates starting the assignment, you must download the following electronic files for their use. You must keep these files secure and candidates must not access them prior to assessment.

- ◆ data sheet 6 – graphic of the logo
- ◆ data sheet 6 – PNG file of DTP layout template
- ◆ data sheet 7 – copy text
- ◆ data sheet 8 – graphic of the dune digger toy
- ◆ data sheet 8 – graphic of the hoverchopper toy
- ◆ data sheet 8 – graphic of Cozzlebots toy
- ◆ data sheet 8 – graphic of the roaming rocket toy
- ◆ data sheet 8 – graphic of an astronaut
- ◆ data sheet 8 – graphic of a young girl
- ◆ data sheet 8 – graphic of a constellation
- ◆ data sheet 8 – graphic of a young boy
- ◆ data sheet 8 – graphic of a circuit board
- ◆ data sheet 8 – graphic of the moon
- ◆ data sheet 8 – graphic of planet earth
- ◆ data sheet 8 – graphic of a rocket
- ◆ data sheet 8 – graphic of Saturn
- ◆ data sheet 8 – graphic of moon texture
- ◆ data sheet 9 – graphic of launch pad
- ◆ data sheet 9 – STEP files of a product display stand with a wall and floor, the roaming rocket toy, the Cozzlebots toy, and the hoverchopper toy

This assignment has three tasks. Candidates must complete the tasks in order.

Each task has a notional time allocated to it.

Task 1 – 21 marks

(suggested time 3 hours and 30 minutes)

- ◆ Tasks a-d: production drawings must be produced electronically and generated from a 3D CAD model produced by the candidate.

Task 2 – 21 marks

(suggested time 3 hours and 30 minutes)

- ◆ Task 2a: must be completed electronically – candidates must label and justify where they have used two design elements and/or principles from the following list: **rhythm, balance, texture, proportion, value and emphasis**. Candidates must also label where they have used **flow text along a path, transparency and reverse**.
- ◆ Task 2b: must be completed electronically.

Task 3 – 8 marks

(suggested time 1 hour)

- ◆ Tasks a and b: candidates should complete this task manually – if they use an electronic method, it must not be 3D CAD software (candidates will gain no marks if they use this software).

Note: candidates must not trace drawings for any part of the assignment. They will gain no marks for traced drawings.

All electronically generated evidence must be printed and compiled for uplift by SQA.

Instructions for candidates

This assessment applies to the assignment for Higher Graphic Communication.

This assignment has 50 marks out of a total of 125 marks available for the course assessment. It assesses the following skills, knowledge and understanding:

- ◆ creativity when responding to graphic design tasks and situations
- ◆ using graphic communication technologies to meet a purpose
- ◆ producing preliminary, production and promotional graphic items in response to a situation or problem
- ◆ applying illustration and presentation techniques to create graphics with relevant visual impact
- ◆ producing 2D and 3D production drawings, applying appropriate standards, protocols and conventions
- ◆ producing promotional graphic publications to meet an agreed content and style
- ◆ reviewing and evaluating your progress, giving justification for your choice of graphic items and the graphic communication techniques employed

This is a closed-book assessment. Your teacher or lecturer will let you know if there are any specific conditions for doing this assessment.

Note: you must not trace drawings for any part of the assignment – you will gain no marks for traced drawings.

In this assessment, you have to produce a range of graphics in response to a brief:

- ◆ in the order presented
- ◆ which assess aspects of the skills and knowledge listed above
- ◆ in 8 hours, excluding the time needed to set up and clear away any equipment, and for any printing that is required

You must not use any text, images, or other items from any other source unless you create them during this 8-hour assignment.

There are three tasks, with marks allocated as follows:

Task 1 – 21 marks: producing production drawings for a dune digger toy
(suggested time 3 hours and 30 minutes)

Task 2 – 21 marks: producing promotional graphics for the product display stand
(suggested time 3 hours and 30 minutes)

Task 3 – 8 marks: producing preliminary graphics for new product proposals
(suggested time 1 hour)

Your teacher or lecturer will provide you with:

- ◆ tasks sheets 1 to 3 – graphic communication briefs
- ◆ data sheets 1 to 12
- ◆ a PNG file of the DTP layout template
- ◆ STEP files of a product display stand with a wall and floor, the roaming rocket toy, the Cozzlebots toy, and the hoverchopper toy
- ◆ electronic files of the graphics shown in data sheets 6, 8 and 9

Submitting your work

You must label each piece of evidence with the task number (for example task 1a), and the back of each page with your:

- ◆ name
- ◆ date of birth
- ◆ Scottish Candidate Number (SCN)
- ◆ centre name
- ◆ centre number

Graphic Communication brief

Cozzlebots, a toy company, are launching a new product.

The new product, a dune digger toy, will be displayed in UK stores alongside other toys from the same product range. Cozzlebots has designed a custom product display stand.

As part of the graphic proposal, Cozzlebots has asked you to create:

- ◆ production drawings to manufacture the dune digger toy
- ◆ a promotional item that will be featured in stores, with relevant desktop-published graphics. Cozzlebots has provided:
 - their company logo, fonts and company colours
 - copy text
 - several pre-approved promotional images

Note: you cannot change the company name, company logo, fonts or company colours

- ◆ a 3D illustrated environment to showcase the product display stand
- ◆ preliminary sketches of product proposals for the Cozzlebots toy range

You have data sheets to guide you through the assignment.

Task 1: dune digger toy

A CAD technician has prepared a series of draft CAD drawings to aid the manufacture of the dune digger toy.

Using the draft CAD drawings and information shown on data sheets 1, 2, 3, 4 and 5, model the dune digger toy components using 3D CAD software.

From these models, produce production drawings based on the dune digger toy.

You may use top-down modelling or bottom-up modelling in your work.

Elevations, end elevations and plan views must be produced in the same orientation as the given orthographic views on each individual data sheet.

- 1a (i) Produce a plan, a stepped sectional elevation through cutting plane Z, and a right-hand end elevation of the cab (part 1). You must produce all views at a scale of 1:4. (4 marks)
- (ii) Produce an elevation, a plan, and an end elevation of the bucket (part 2). You must produce all views at a scale of 1:2. (2 marks)
- (iii) Complete your drawing to include hidden detail, appropriate dimensions for manufacture and annotations. (3 marks)
- 1b Produce an elevation, a sectional plan through cutting plane Y, and a sectional end elevation through cutting plane X of the assembled dune digger toy. You must produce the three orthographic views at a scale of 1:4.
- Your drawing must include an enlargement view to show how the cab (part 1) and the hook (part 4) fit together. The enlargement view must display an angular dimension of 45° between the cab (part 1) and the hook (part 4), as shown in data sheet 1.
- Your drawing must also include an enlargement view to show how the cab (part 1) and the wheel (part 3) fit together.
- Do not show hidden detail. (6 marks)
- 1c Produce an exploded isometric view, in the same orientation as shown on data sheet 1, of the assembled dune digger toy. (3 marks)

1d Include the following British Standard conventions in your drawings:

- linear, radial, diameter and angular dimensions
- third angle projection symbol and title block including relevant information
- labelled views

(3 marks)

Note: you must create all the production drawings for task 1 electronically and print out all your work.

You should complete task 1 on four or five single-sided A3-sized pages.

You should spend approximately 3 hours and 30 minutes on task 1.

Your completed assignment (tasks 1 to 3) should be on no more than 10 single-sided A3-sized pages.

Task 2: promotional graphics for product display stand

A product display stand for the dune digger toy will be placed in UK stores. A three-panel information graphic will be attached to the backboard of the product display stand to promote the range of Cozzlebots products.

Data sheets 6, 7, 8, 9 and 10 contain information on the proposed three-panel information graphic and the 3D computer rendered environment of the product display stand.

Cozzlebots has asked you to create:

- ◆ graphics for the three-panel information graphic, which effectively promote the company. They have provided:
 - an A3 template in PNG file format
 - a company logo, fonts and company colours
 - copy text
 - several pre-approved promotional imagesNote: you cannot alter the company name, company logo, fonts or company colours
- ◆ a 3D computer rendered environment of the product display stand, which includes the assembled dune digger toy you created in task 1

Produce promotional graphics, using the information on data sheets 6, 7, 8, 9 and 10.

2a Using data sheets 6, 7 and 8, produce a **full-size** version of your desktop-published three-panel information graphic.

You should use the file 'data sheet 6 - PNG file of DTP layout template' to ensure the correct layout shape is created.

Your layout must include:

- ◆ **two** design principles and/or elements from:
 - rhythm
 - balance
 - texture
 - proportion
 - value
 - emphasis

You must include appropriate annotation to justify how you have used both of your chosen design principles and/or elements.

- ◆ effective use of the desktop-publishing techniques **flow text along a path**, **transparency**, and **reverse**

You must clearly label where you have used these techniques.

- ◆ the company name, company logo, a minimum of one font and all four colours from data sheet 6
- ◆ an area that contains no copy text
This is highlighted on data sheet 6.
- ◆ the header, headline, extended text and footer from data sheet 7
- ◆ at least three images from data sheet 8

You can add any other graphic items as long as you create them during this 8-hour assignment.

You can use the images on data sheet 8 as they are, or you can edit them to suit your design.

(12 marks)

2b Using the assembled dune digger toy you created in task 1, produce pictorial illustrations of your dune digger toy sited on the product display stand STEP file.

You must produce pictorial illustrations from **two** different viewpoints, similar to those shown on **data sheet 10**.

You must print each viewpoint on an individual landscape sheet. You must scale each viewpoint as large as possible to fit the sheet.

Your illustrations must include:

- ◆ the STEP file of the product display stand provided, which includes a floor and a wall
- ◆ the assembled dune digger toy, suitably scaled and placed on **surface B** of the product display stand STEP file
Surface B is highlighted on data sheet 9.
- ◆ the remaining three STEP files provided
These must be suitably scaled and similarly positioned to the locations highlighted on data sheet 9. Illustrated examples of the STEP files are provided on data sheet 9.
- ◆ the colour and image specifications for each STEP file, as highlighted on data sheet 9
- ◆ appropriate highlights and shadows applied to the assembled dune digger toy and STEP files

(9 marks)

Note: you may attach the image of the three-panel information graphic from task 2a to the backboard of the product display stand, however, you are not required to do so.

You must produce task 2a electronically and print out all your work. You must also create all 3D computer renders for task 2b electronically and print out all your work.

You should complete task 2 on three single-sided A3-sized pages.

You should spend approximately 3 hours and 30 minutes on task 2.

Your completed assignment (tasks 1 to 3) should be on no more than 10 single-sided A3-sized pages.

Task 3: Cozzlebots sketches

A graphic artist has produced a series of sketches of new products for the Cozzlebots toy range.

Using the preliminary sketches shown on data sheets 11 and 12, produce additional pictorial and orthographic sketches to showcase the new products.

You will not gain any marks if you measure, trace or use any drawing instruments (other than a straight edge). If you use an electronic method, it must not be 3D CAD software. You will gain no marks if you use this software.

3a Produce a preliminary **pictorial** sketch of Cozzlebots Toy A, using the information on data sheet 11.

- ◆ Your sketch must accurately represent the Cozzlebots toy shown in the orthographic sketch on data sheet 11.
- ◆ You do not need to include colour, highlights or shadows.
- ◆ You do not need to sketch the eyes and mouth of the Cozzlebots toy.

(4 marks)

3b Produce a preliminary **orthographic** sketch of Cozzlebots Toy B, using the information on data sheet 12.

- ◆ Your sketch must accurately represent the Cozzlebots toy shown in the pictorial sketches on data sheet 12.
- ◆ Your sketch must include an elevation, a plan, and an end elevation of the Cozzlebots toy, in the orientation highlighted on data sheet 12.
- ◆ Your orthographic sketch must be produced in third angle projection.
- ◆ Your orthographic sketch must include centre lines and hidden detail.
- ◆ You do not need to include colour, highlights or shadows.
- ◆ You do not need to sketch the eyes and mouth of the Cozzlebots toy.

(4 marks)

Note: you can complete task 3 manually or electronically. If you complete task 3 electronically, you must print out your work.

You should complete task 3 on one or two single-sided A3-sized pages.

You should spend approximately 1 hour on task 3.

Your completed assignment (tasks 1 to 3) should be on no more than 10 single-sided A3-sized pages.

Data sheet 1 – draft CAD drawing of assembled dune digger toy

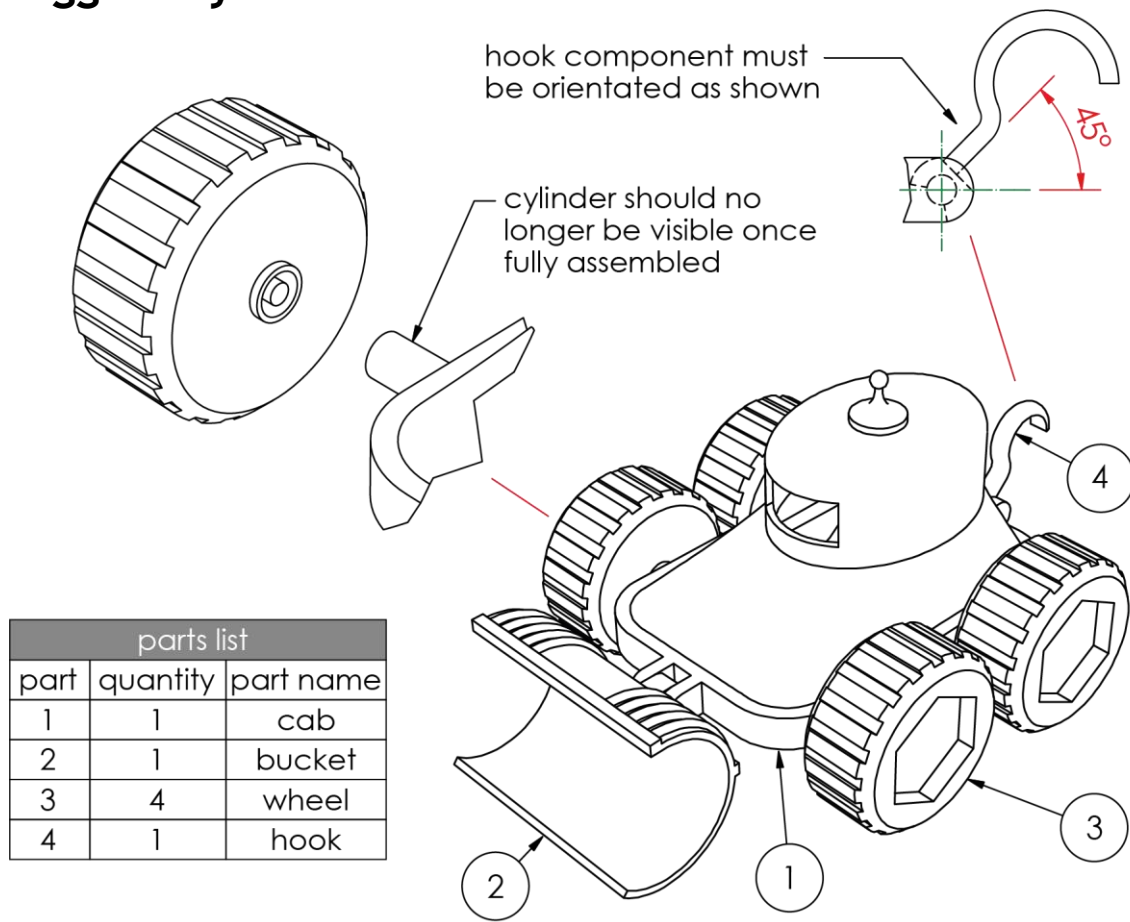

parts list		
part	quantity	part name
1	1	cab
2	1	bucket
3	4	wheel
4	1	hook

ASSEMBLY DETAILS

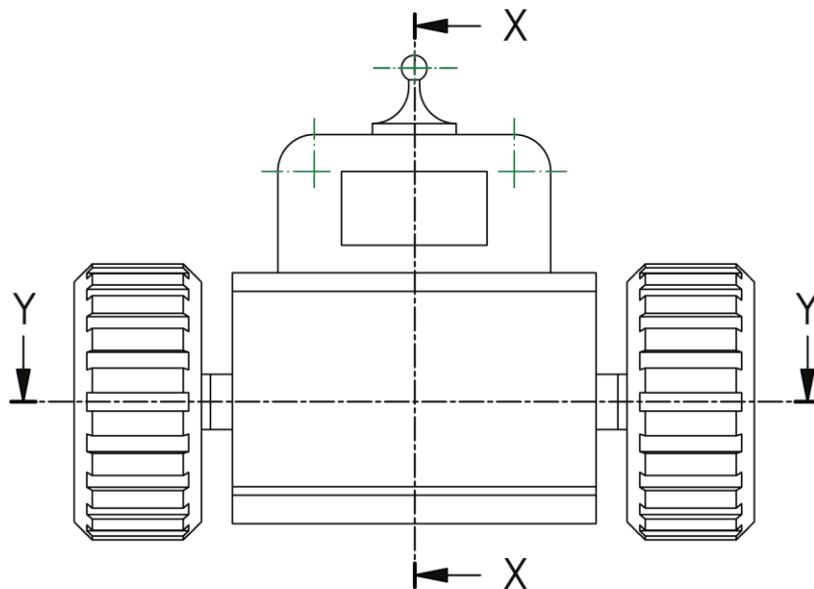

ORTHOGRAPHIC VIEW
(ELEVATION)

Not to scale

Data sheet 2 – draft CAD drawing of cab (part 1)

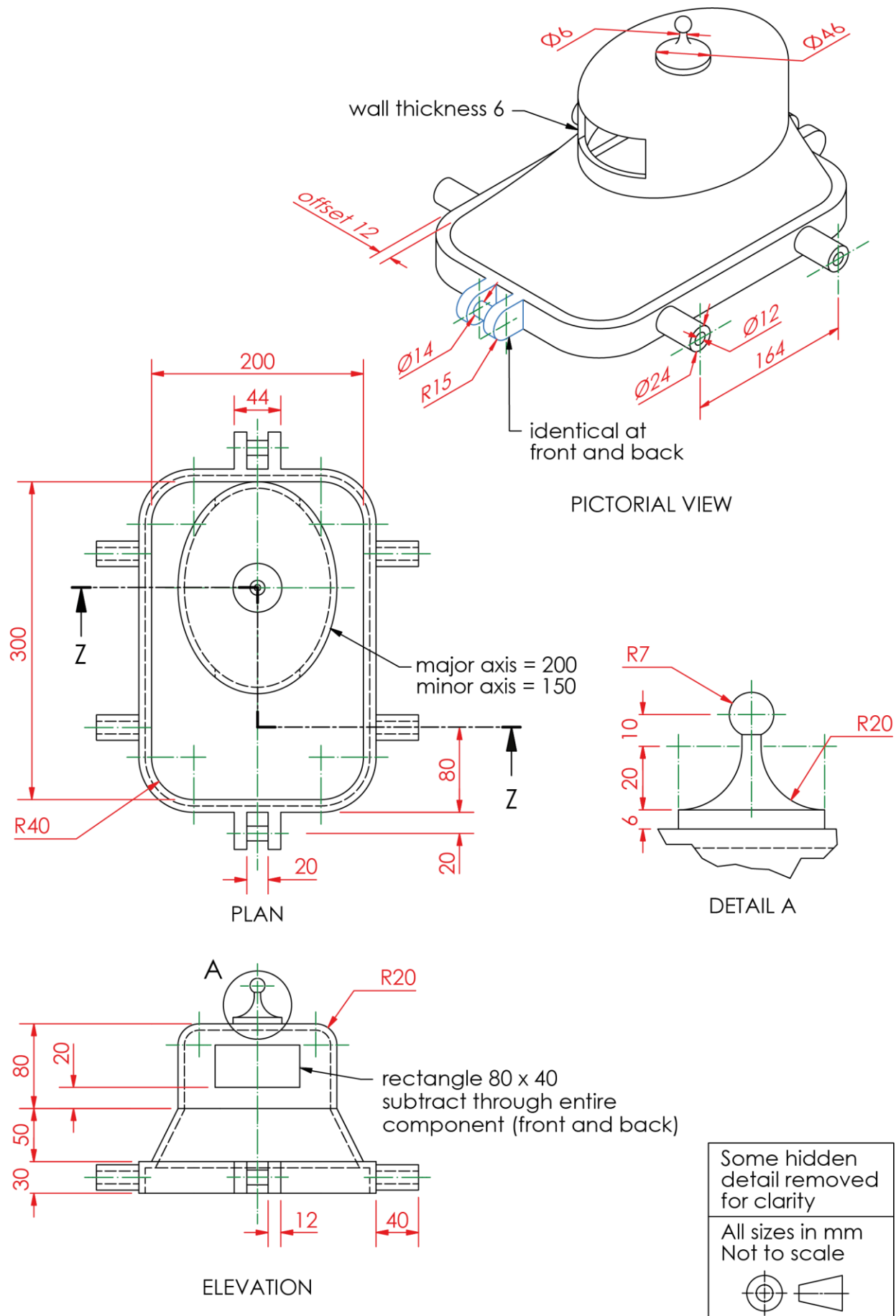

Data sheet 3 – draft CAD drawing of bucket (part 2)

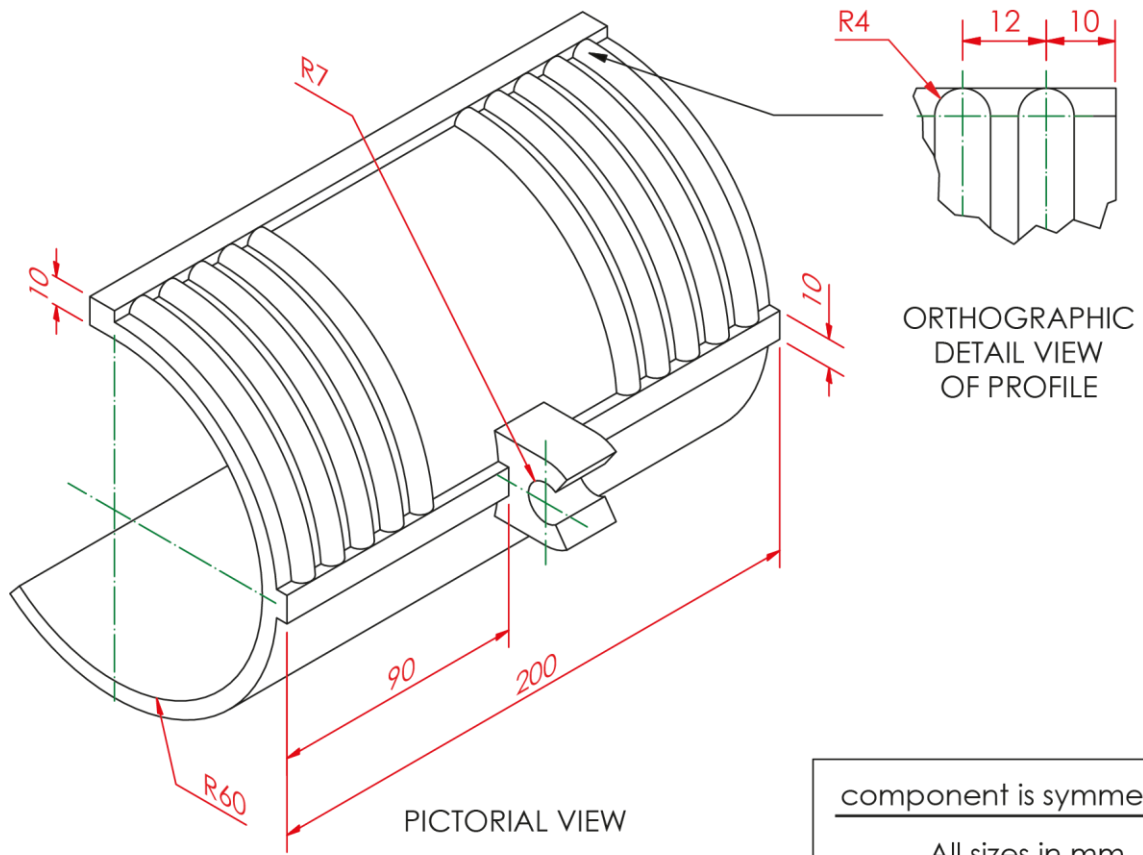

component is symmetrical
All sizes in mm
Not to scale

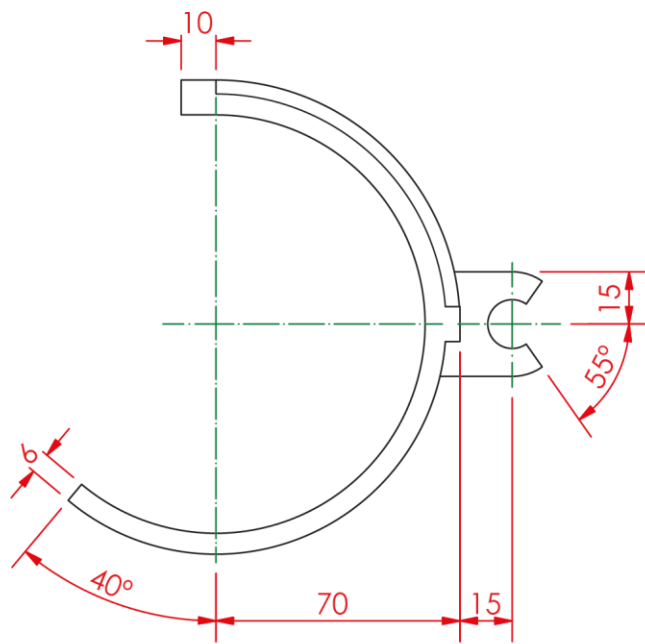

Data sheet 4 – draft CAD drawing of wheel (part 3)

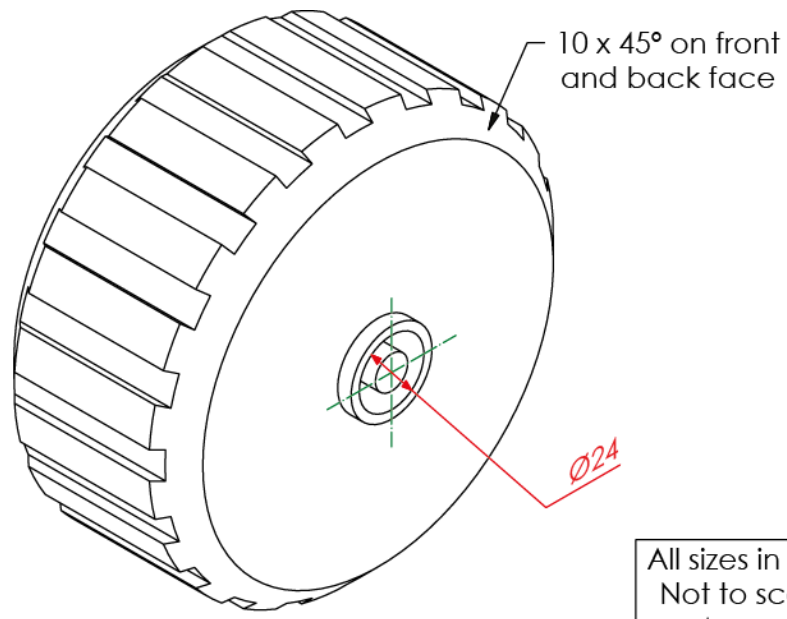

PICTORIAL VIEW

All sizes in mm
Not to scale

Hidden detail of tyre tread removed to aid clarity in elevation

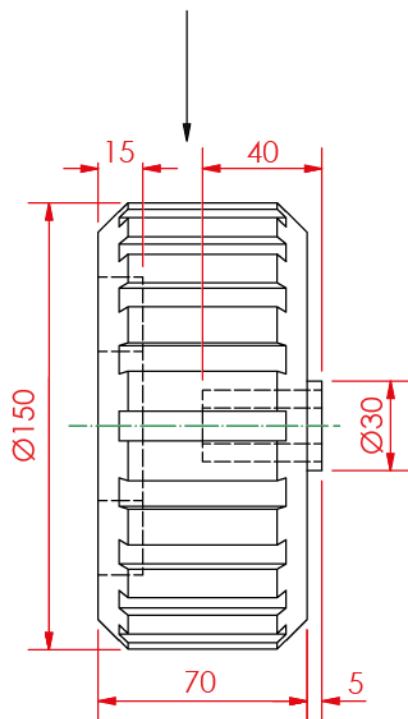

ELEVATION

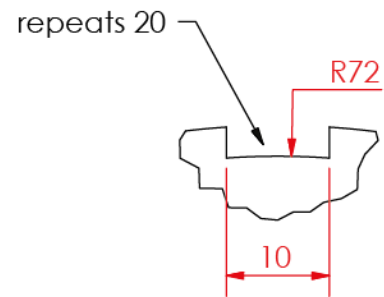

DETAIL A

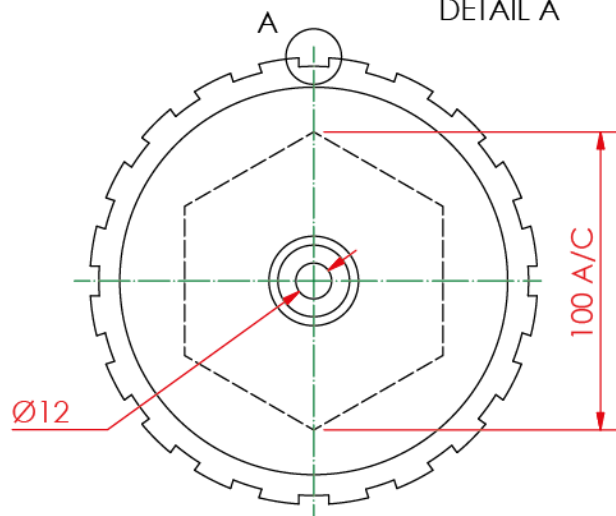

END ELEVATION

Data sheet 5 – draft CAD drawing of hook (part 4)

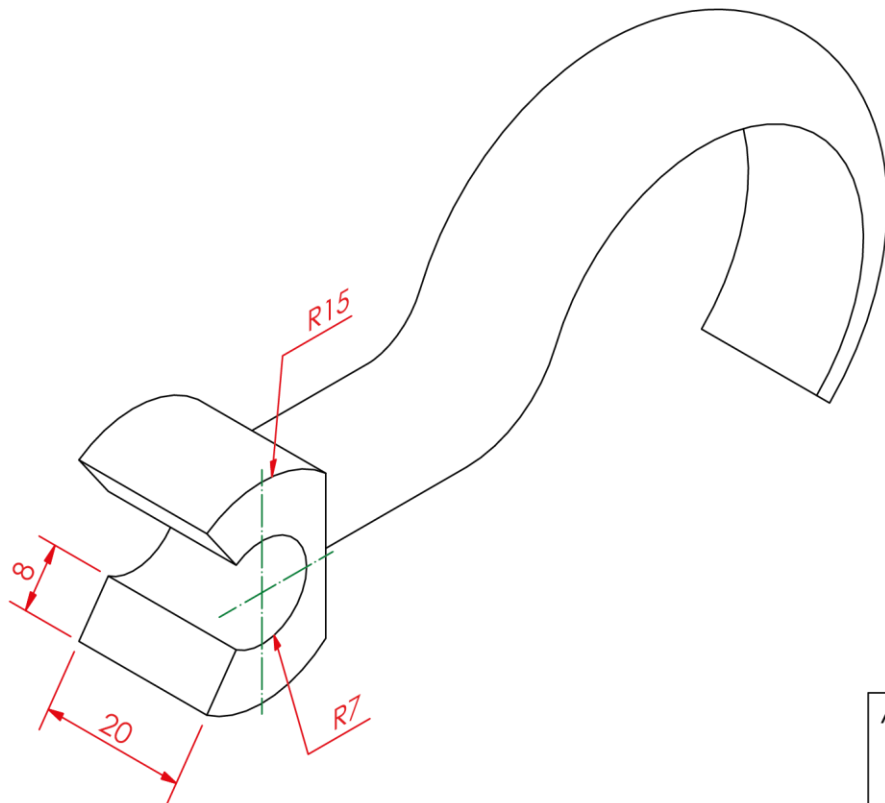

PICTORIAL VIEW

All sizes in mm
Not to scale

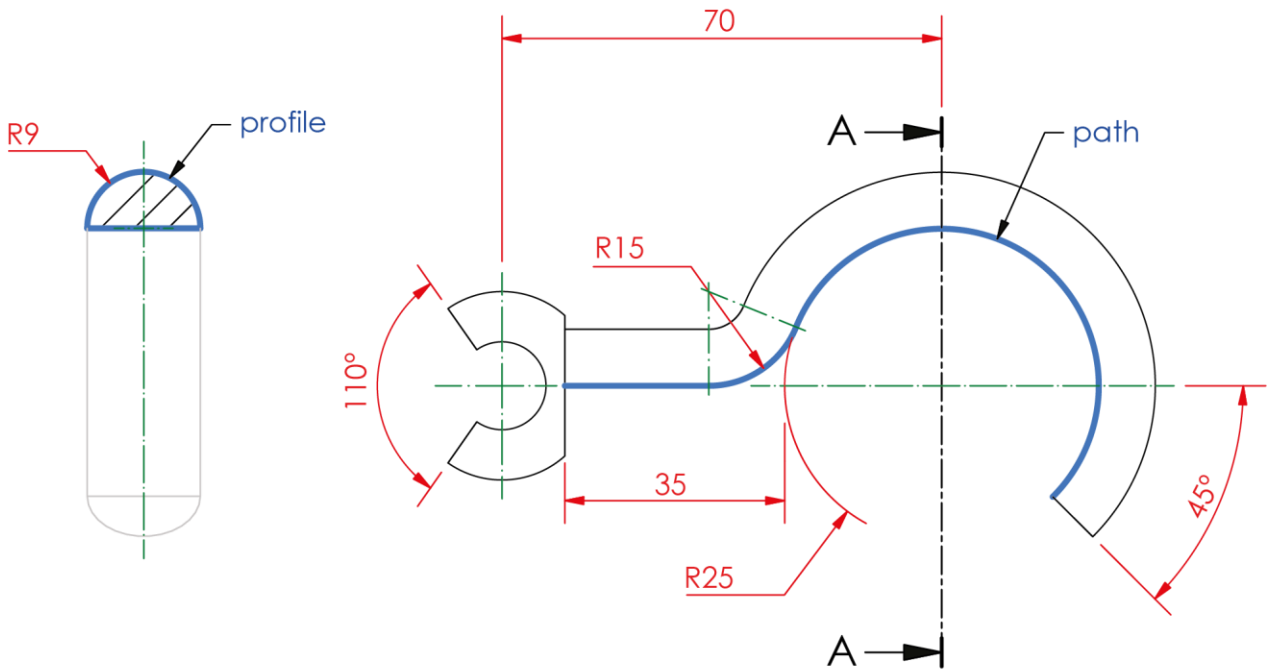

SECTION A-A

END ELEVATION

Data sheet 6 – three-panel product display stand information graphic

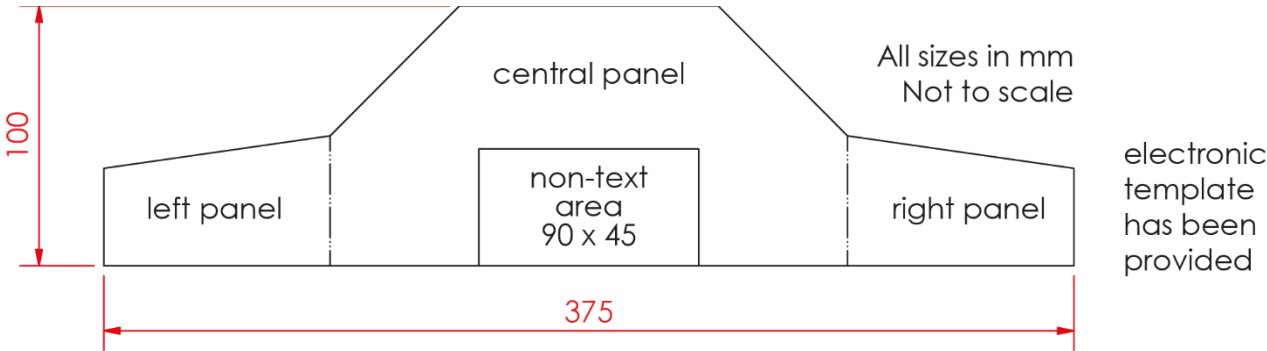

approved colours

1	C: 93 M: 73 Y: 8 K: 1	2	C: 50 M: 91 Y: 0 K: 0
3	C: 9 M: 95 Y: 90 K: 1	4	C: 48 M: 40 Y: 40 K: 4

approved fonts

- Century Gothic
- Lucida Sans
- **Impact**
- Calibri

logo

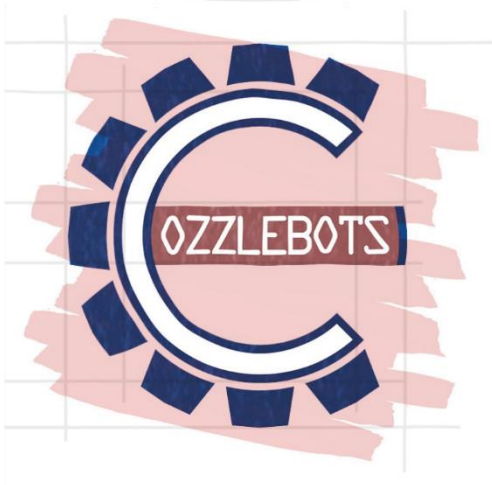

Data sheet 7 – copy text

Header – Cozzlebots 2022

Headline – The Cozzlebots Product Range

Extended text

Cozzlebots are fast becoming the most popular range of toys in the UK! All Cozzlebots products are available in a range of styles and colours, allowing you to fully customise your Cozzle-collection.

The Cozzlebots – The Cozzlebots are a robot species that live on the planet Cozatica.

Roaming Rocket – The Cozzlebots use the Roaming Rocket to travel to near-by planets.

Dune Digger – The Dune Digger is used by the Cozzlebots to excavate on the surface of their planet, Cozatica.



Hoverchopper – This machine is used frequently by Cozzlebots and is the main source of transport on planet Cozatica and in the Emerald Galaxy.

Footer – For more information visit our website at www.cozzlebots.co.uk.

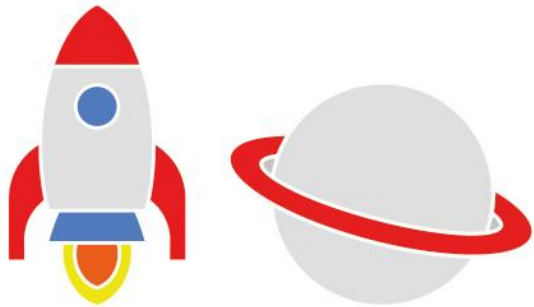
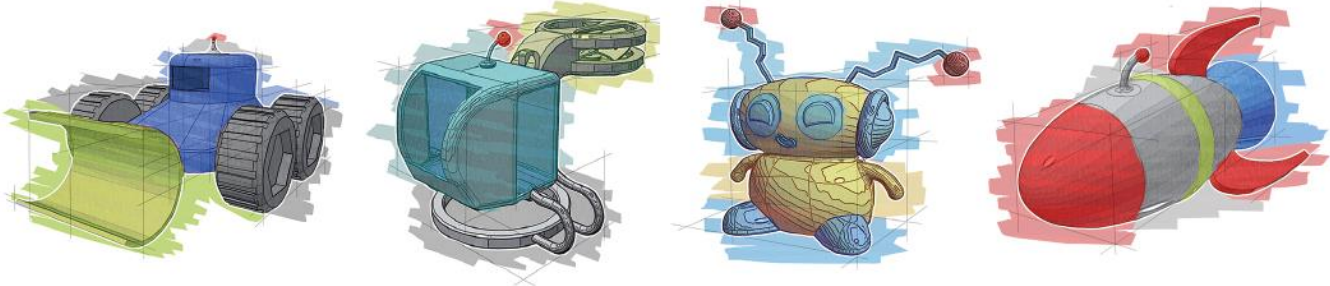



Data sheet 8 – image bank

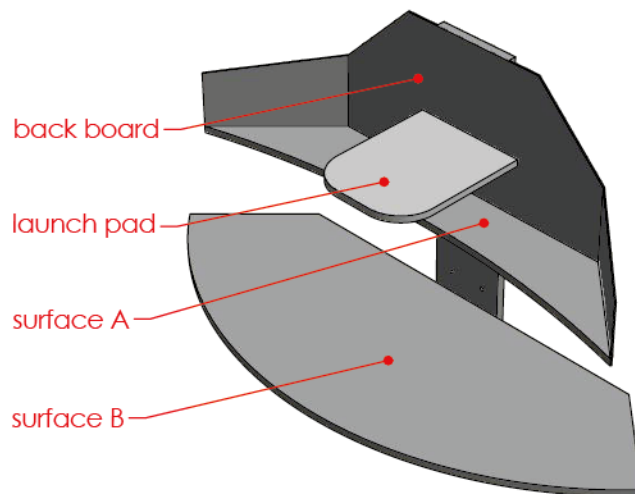

Data sheet 9 – 3D computer rendered environment

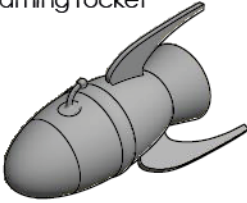
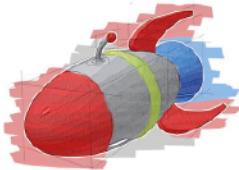
display stand specification		
surface	details	image
back board	any material, colour or image is permitted	
launch pad	must include image of launch pad	
surface A	any material, colour or image is permitted	
surface B	must include image of Moon texture	

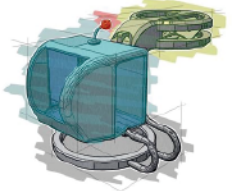
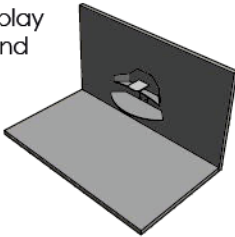

STEP file specification		
STEP file	details	example
roaming rocket 	Must be placed on the Launch Pad surface. A minimum of 3 colours from the approved colour list must be applied. An example is provided. Approved colour list: red, blue, yellow, white, grey	
cozzlebot 	Must be placed on Surface A. A minimum of 3 colours from the approved colour list must be applied. An example is provided. Approved colour list: red, blue, yellow, white, grey	
hoverchopper 	Must be placed on Surface B. A minimum of 3 colours from the approved colour list must be applied. An example is provided. Approved colour list: red, blue, yellow, white, grey	
display stand 	Display Stand specification is provided above. Any appropriate material/colour is permitted for wall and floor.	

Data sheet 10 – 3D computer rendered environment viewpoints

Landscape layout of viewpoint 1

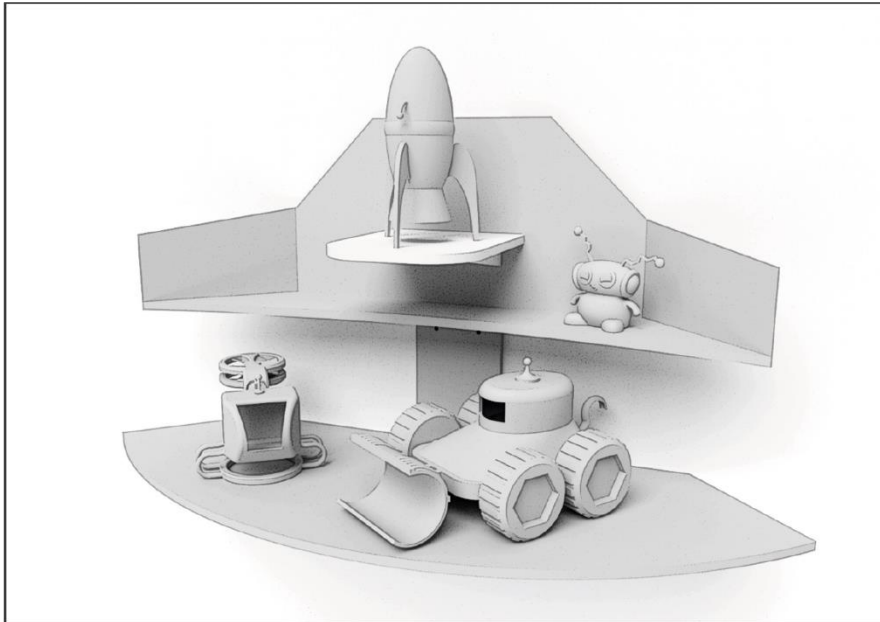

Landscape layout of viewpoint 2

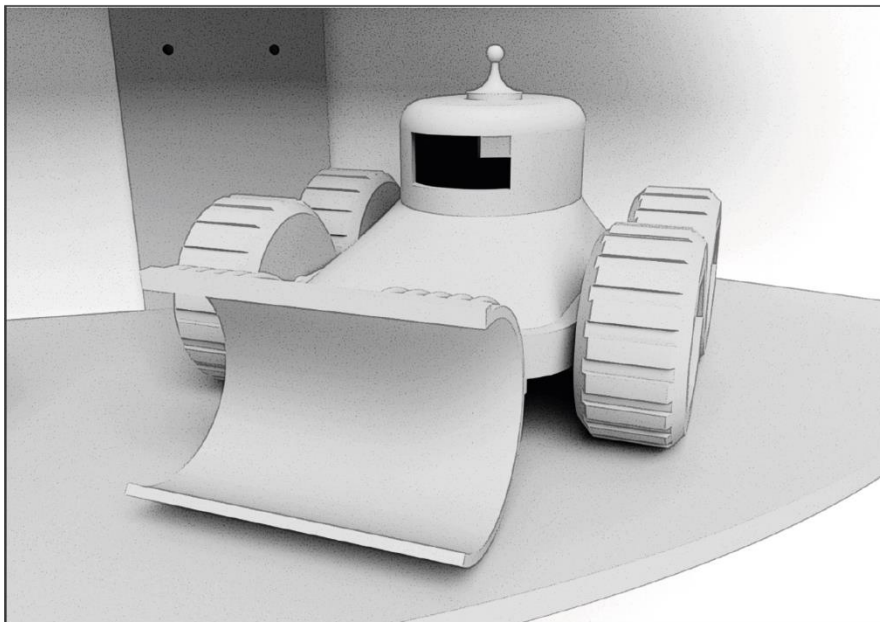

Data sheet 11 – Cozzlebots toy A preliminary sketch

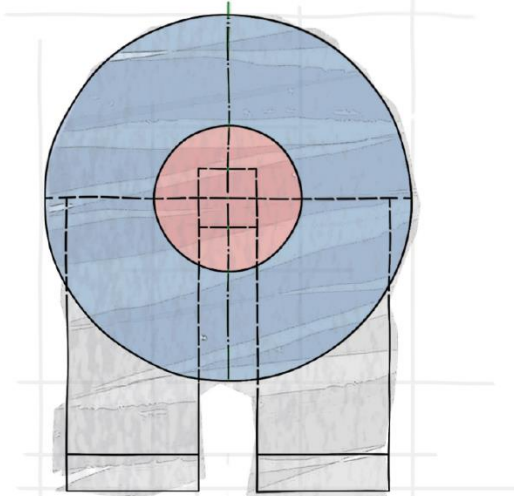

PLAN

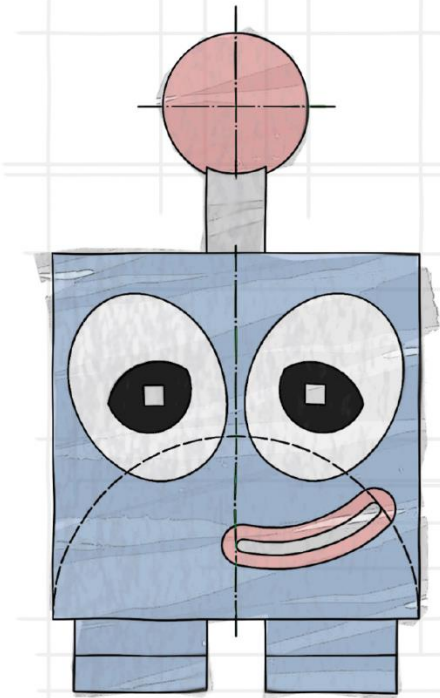

ELEVATION

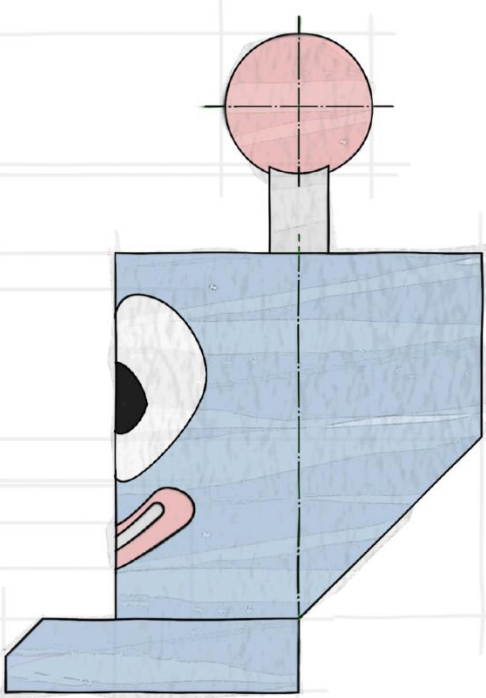

END ELEVATION

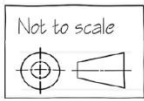

Data sheet 12 – Cozzlebots toy B preliminary sketch

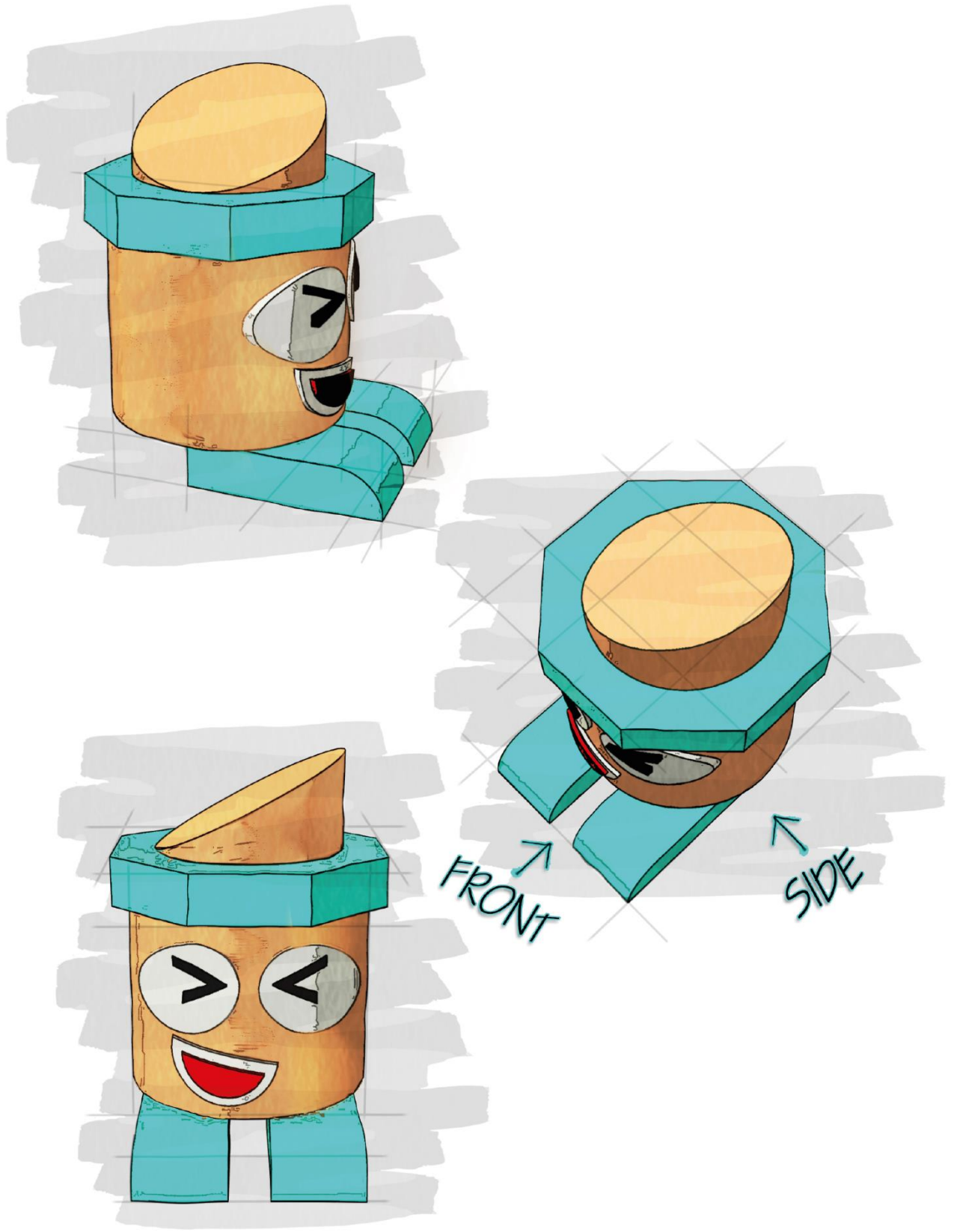

Copyright acknowledgements

Data sheets 8 and 9: various images – Creative Commons CC0 and sourced www.pexels.com.

Administrative information

Published: December 2021 (version 1.0)

History of changes

Version	Description of change	Date

Security and confidentiality

This document can be used by SQA approved centres for the assessment of National Courses and not for any other purpose.

This document may only be downloaded from SQA's designated secure website by authorised personnel.

© Scottish Qualifications Authority 2021