

FOR OFFICIAL USE



--	--	--	--	--	--

National
Qualifications
2022 MODIFIED

Mark

--

X835/76/01

Graphic Communication

MONDAY, 16 MAY
1:15 PM – 3:15 PM



Fill in these boxes and read what is printed below.

Full name of centre

--

Town

--

Forename(s)

--

Surname

--

Number of seat

--

Date of birth

Day

--	--

Month

--	--

Year

--	--

Scottish candidate number

--	--	--	--	--	--	--	--	--	--

Total marks — 75

Attempt ALL questions.

All dimensions are in mm.

All technical sketches and drawings use third angle projection.

You may use rulers, compasses or trammels for measuring.

In all questions you may use sketches and annotations to support your answer if you wish.

Write your answers clearly in the spaces provided in this booklet. Additional space for answers is provided at the end of this booklet. If you use this space you must clearly identify the question number you are attempting.

Use **blue** or **black** ink.

Before leaving the examination room you must give this booklet to the Invigilator; if you do not, you may lose all the marks for this paper.



Total marks — 75
Attempt ALL questions

1. A garden landscaping company has invested in new software. It allows clients to scan site plans and view them as 3D rendered models as shown below.

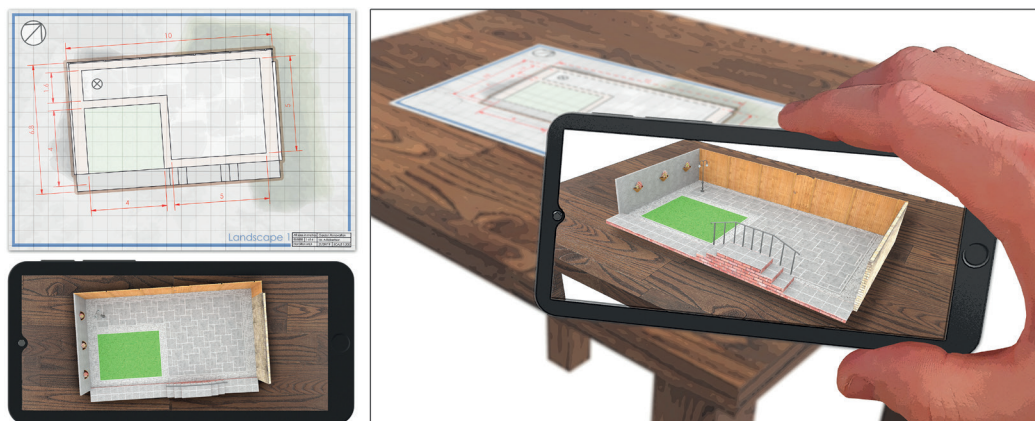

- (a) Describe, giving two reasons, how the use of this software could aid discussions with clients.

2

- (b) When creating preliminary sketches of ideas the drawings are often digitally sketched on a touch-screen tablet.
Describe two advantages to a landscape architect of using digital sketching.

2



1. (continued)

- (c) A client has requested that a small outdoor workshop is constructed. The graphics shown below were generated by a CAD technician during the planning stages of the project.



Graphic 1

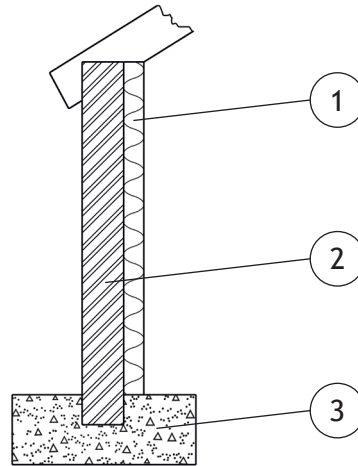

Graphic 2

- (i) Explain, giving two reasons, why the CAD technician would use a CAD library when producing construction drawings for this project.

2

[Turn over



1. (c) (continued)

The CAD technician frequently uses the dxf file format when saving CAD drawings.

(ii) Explain why dxf is a suitable format for CAD drawings.

1

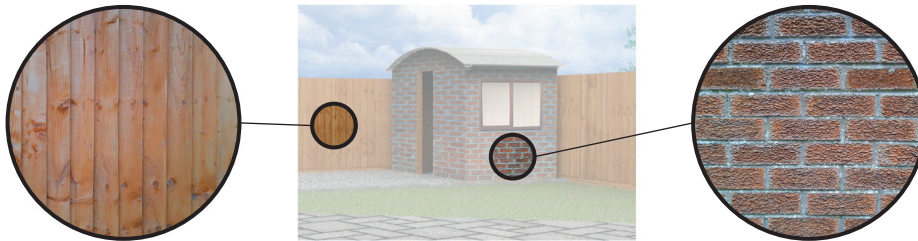

(d) Real outdoor textures were captured and applied to the external surfaces of the 3D CAD illustration as shown above.

(i) State the name of a suitable input device that could be used to capture the image of the outdoor textures.

1

(ii) Describe three benefits to the landscaping company of only using images created by their own staff, rather than using stock images.

3



STONE BENCH

All sizes in mm
Not to scale

The technical drawing includes three views:

- PLAN:** A rectangular top view with a length of 365 mm and a width of 30 mm. A dashed line indicates a hole in the center.
- ELEVATION:** A front view showing a trapezoidal shape with a top width of 200 mm, a bottom width of 280 mm, and a height of 180 mm. A decorative plate with a grid of star-shaped holes is shown on the front face. A section line 'A-A' is drawn across the plate.
- DETAIL A (NOT TO SCALE):** A circular magnified view of one star-shaped hole, showing an 'Outer Profile' and an 'Inner Profile'.

A **RENDERED ILLUSTRATION** shows the stone bench in a 3D perspective. It is a dark grey stone with a decorative plate on the front face. The plate has a grid of yellow star-shaped holes. A label 'Decorative Plate' points to the front face.

(e) A set of production drawings for a stone bench has been produced by the CAD technician, as shown above.

(i) State the type of array used to produce the repeated feature shown in the elevation.

1

(ii) Complete the table below to include the correct spacing for the array shown in the elevation.

2

Array		
Direction	Repeats	Spacing
→	5	
↓	4	

(iii) State the name of the 2D CAD tool used to ensure that the outer profile is the same shape as the inner profile on DETAIL A.

1



1. (continued)

The production drawing for the stone bench leg is shown below.

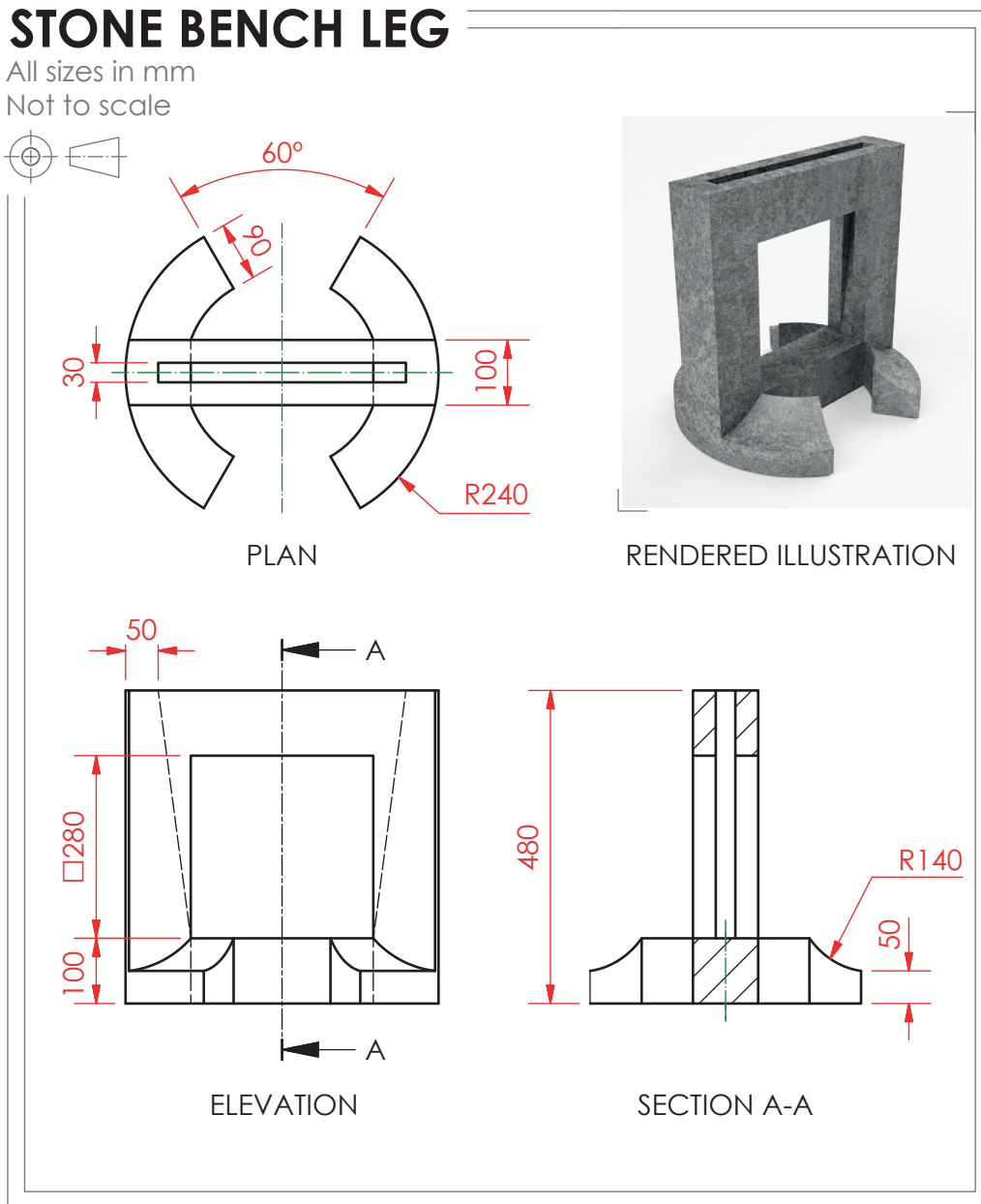

1. (continued)

(f) Describe the 3D CAD modelling techniques used to create the stone bench leg.

You must make reference to the dimensions shown in the 2D production drawing on the opposite page to answer this question.

You may use sketches to support your answer.

8



2. A CAD technician has created a 3D model of a coffee machine, shown below. The coffee machine has multiple components, and some have been labelled.



- (a) Describe the benefits of using **top-down modelling** to create the wand cap. 2

- (b) **Bottom-up modelling** was used to create other components of the coffee machine. Describe the process of bottom-up modelling. 2



2. (continued)

The coffee machine water reservoir component was created using 3D CAD modelling software. Steps in the modelling process are shown below.

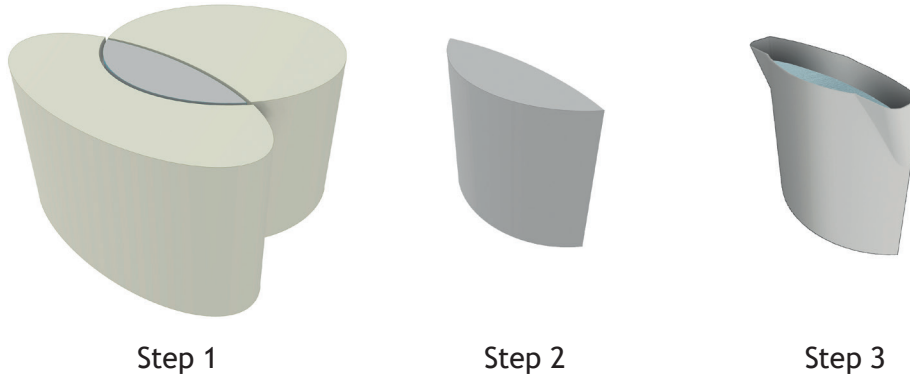

(c) State the name of the modelling edit used between Step 1 and Step 2.

_____ 1

(d) An error was made during the modelling process of the drip tray.



MODELLING TREE

- > 1 Extrude main body shape
- > 2 Fillet outer edges
- > 3 Extrude subtract arrayed holes
- > 4 Shell to correct wall thickness

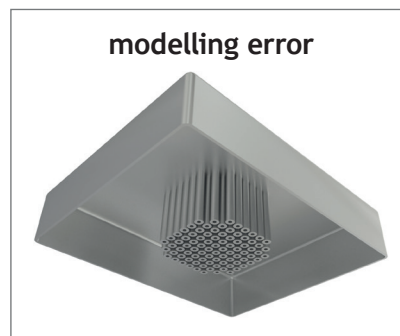
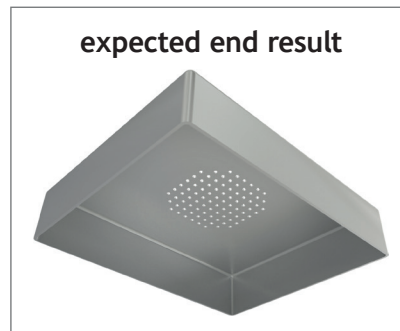

Describe the change that needs to be made to the modelling tree to fix the error and achieve the expected end result.

_____ 1



2. (continued)

The production drawing for the coffee filter is shown below.

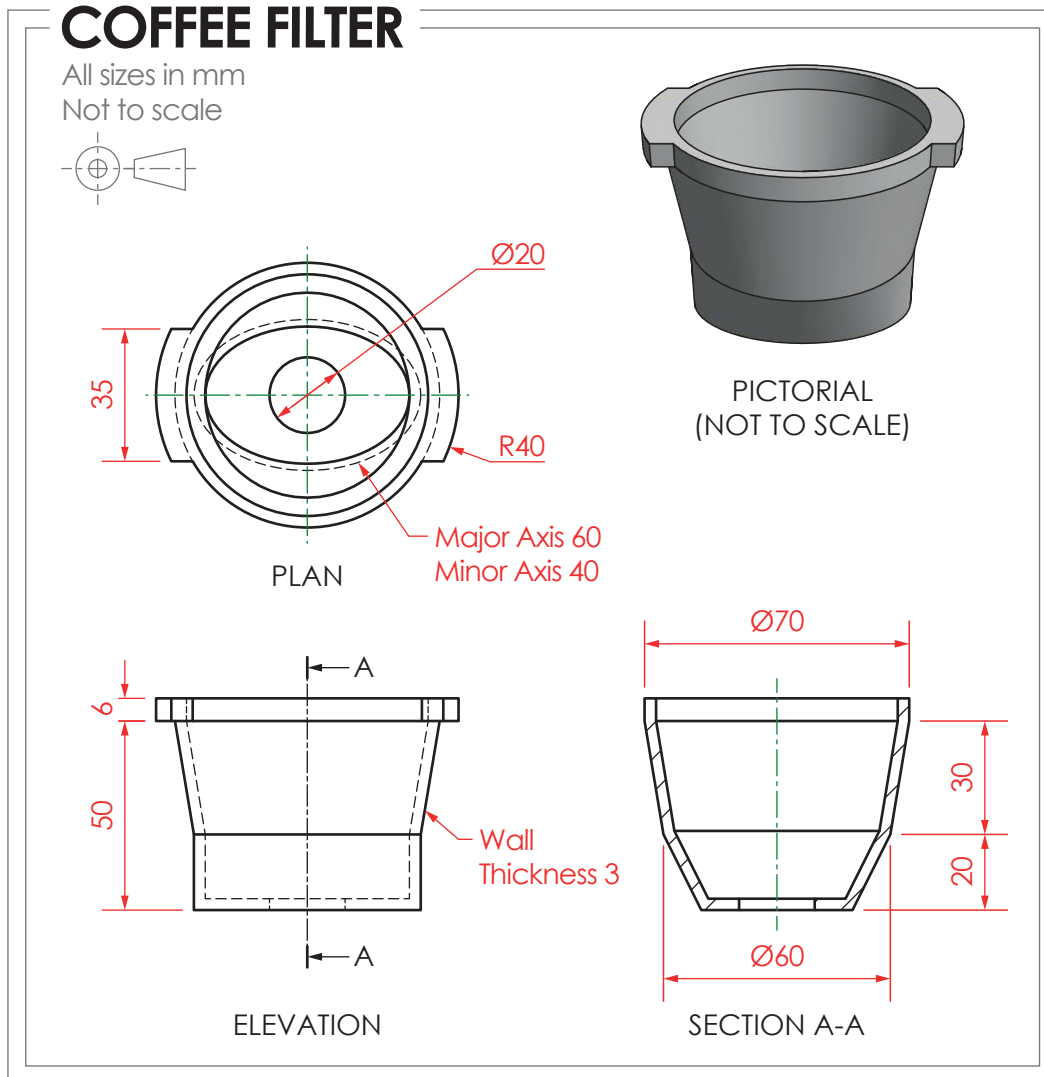

* X 8 3 5 7 6 0 1 1 0 *

2. (continued)

(e) Describe the 3D CAD modelling techniques used to create the coffee filter.

You must make reference to the dimensions shown in the 2D production drawing on the opposite page to answer this question.

You may use sketches to support your answer.

6



2. (continued)

The production drawing for the steam wand is shown below.

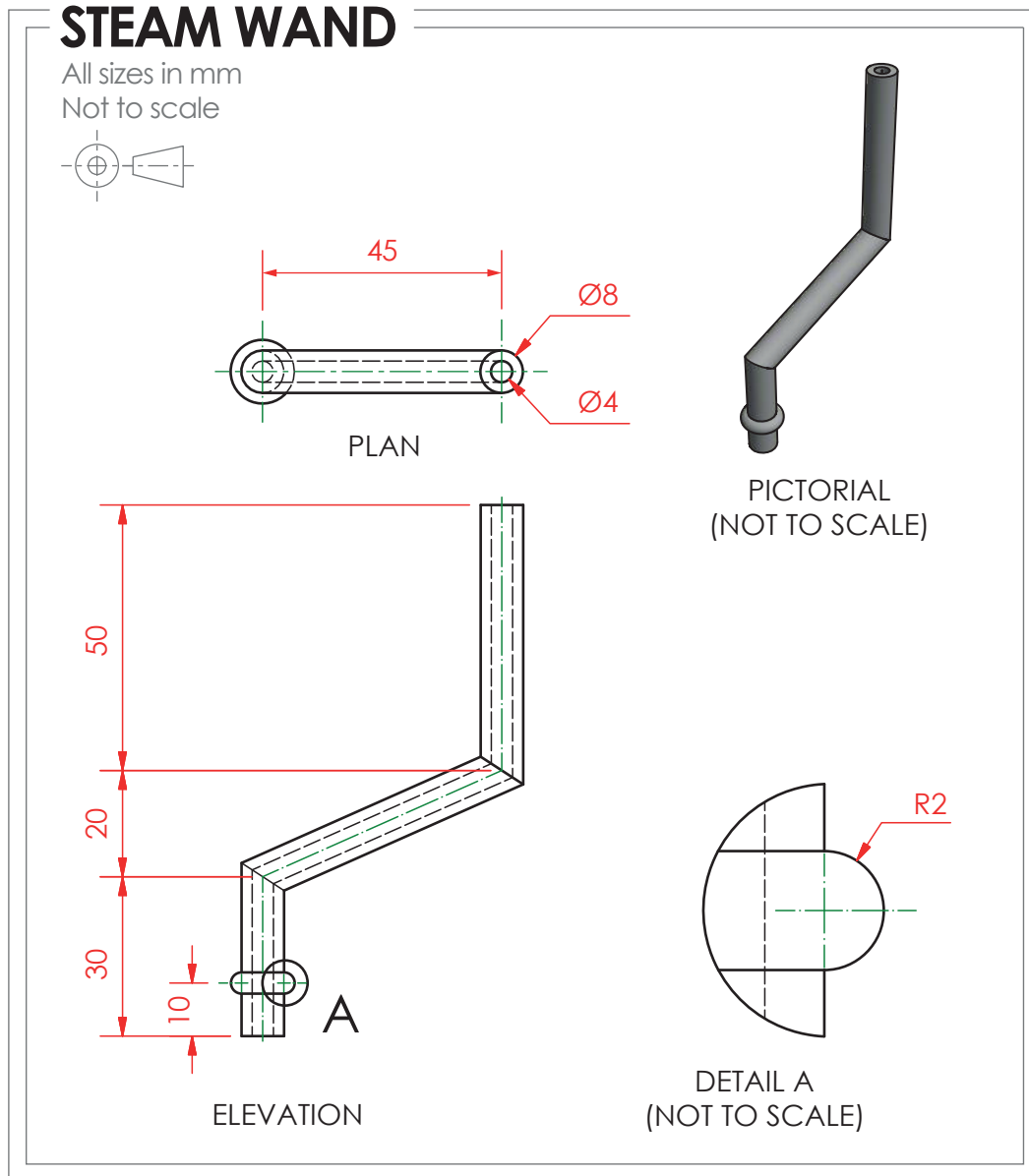

2. (continued)

(f) Describe the 3D CAD modelling techniques used to create the steam wand.

You must make reference to the dimensions shown in the 2D production drawing on the opposite page to answer this question.

You may use sketches to support your answer.

4



2. (continued)

A graphic designer for the Expres Coffee company created **Draft 1** as an idea for a loyalty card.

DTP edits were made to improve the layout. These are shown on **Draft 2**.

The guidelines used during the production of both DTP layouts are shown in green.

Draft 1

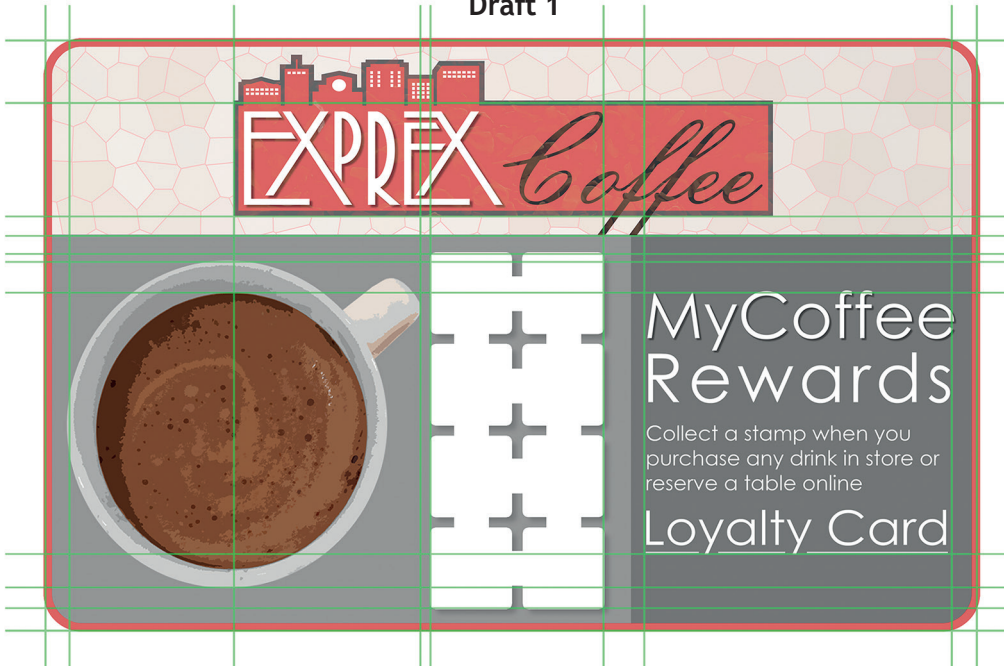

Draft 2



* X 8 3 5 7 6 0 1 1 4 *

2. (continued)

(g) Explain why the following design elements and principles have been used to improve the layout in **Draft 2**.

(i) Alignment _____ 2

(ii) Depth _____ 2

(iii) Unity _____ 2

(h) Registration marks were added to the pre-press copy of the loyalty card, as shown below.

Describe the purpose of registration marks in printing. 2





3. A proposal for a sheet metal garden chair is shown on the supplementary sheet for use with question 3. The panels that form the back and seat have been removed from the orthographic views for clarity.

You must use the graphic provided on the supplementary sheet for use with question 3 to answer this question.

- (a) Indicate the correct auxiliary view for direction A by ticking (✓) a box below.

You may use rulers, compasses or trammels for measuring.

1

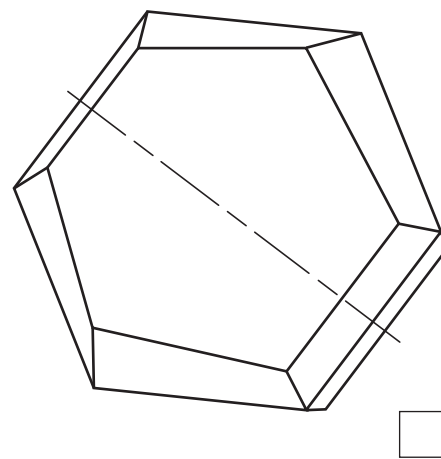
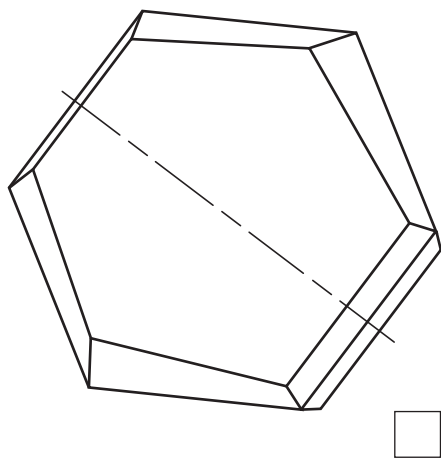
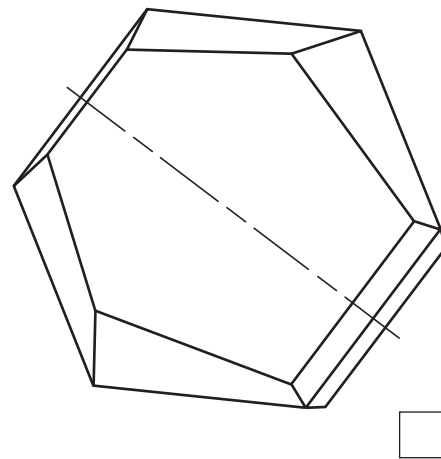
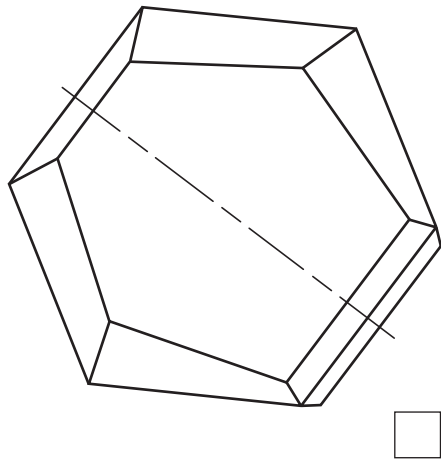

3. (continued)

(b) Indicate the correct auxiliary view for direction B by ticking (✓) a box below.
You may use rulers, compasses or trammels for measuring.

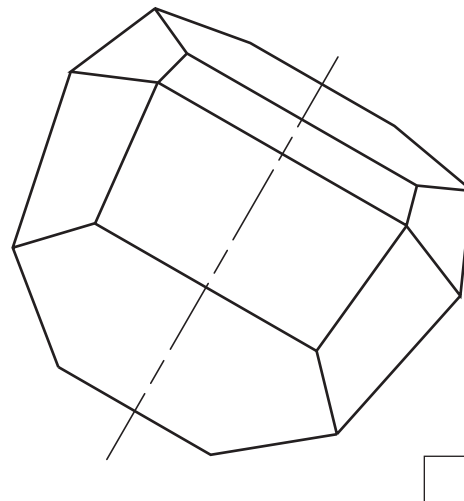
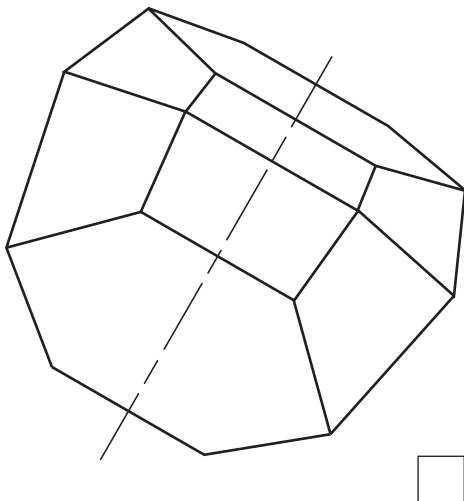
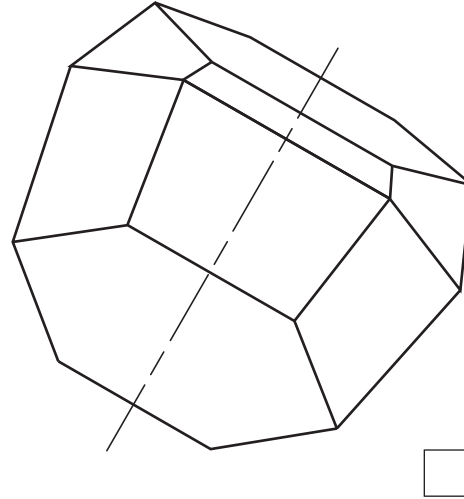
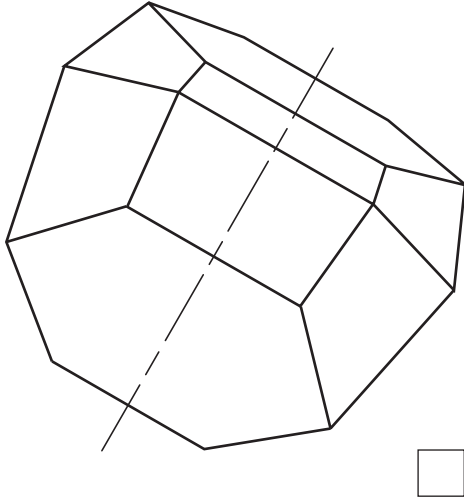

[Turn over



3. (continued)

(c) Indicate the correct auxiliary view for direction C by ticking (✓) a box below.
You may use rulers, compasses or trammels for measuring.

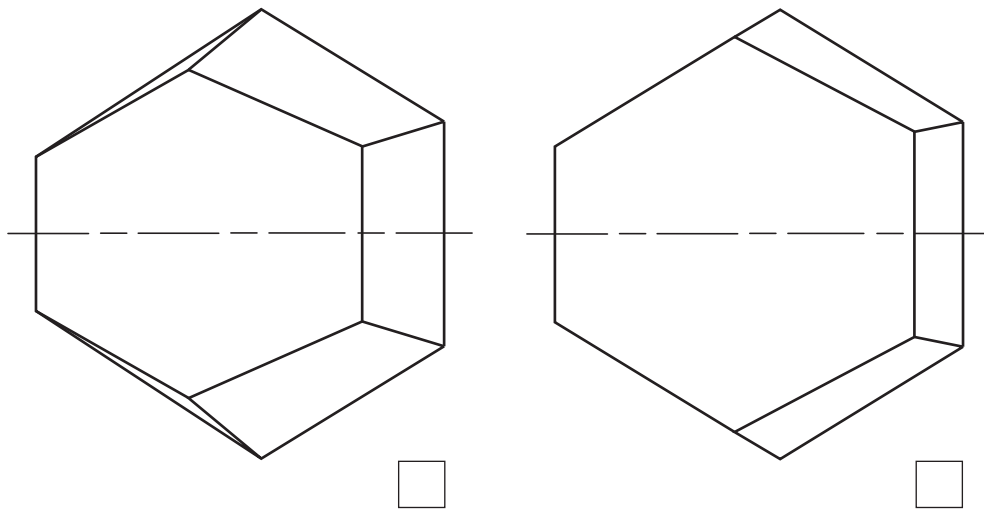
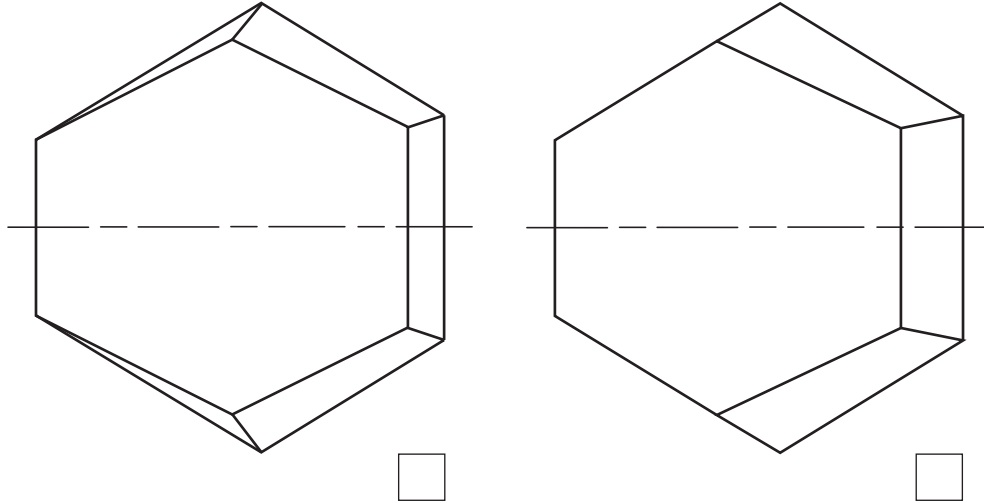

3. (continued)

MARKS DO NOT WRITE IN THIS MARGIN

The chair will have different shapes cut out on various faces. CAD illustrations and orthographic views of the proposal are shown below.

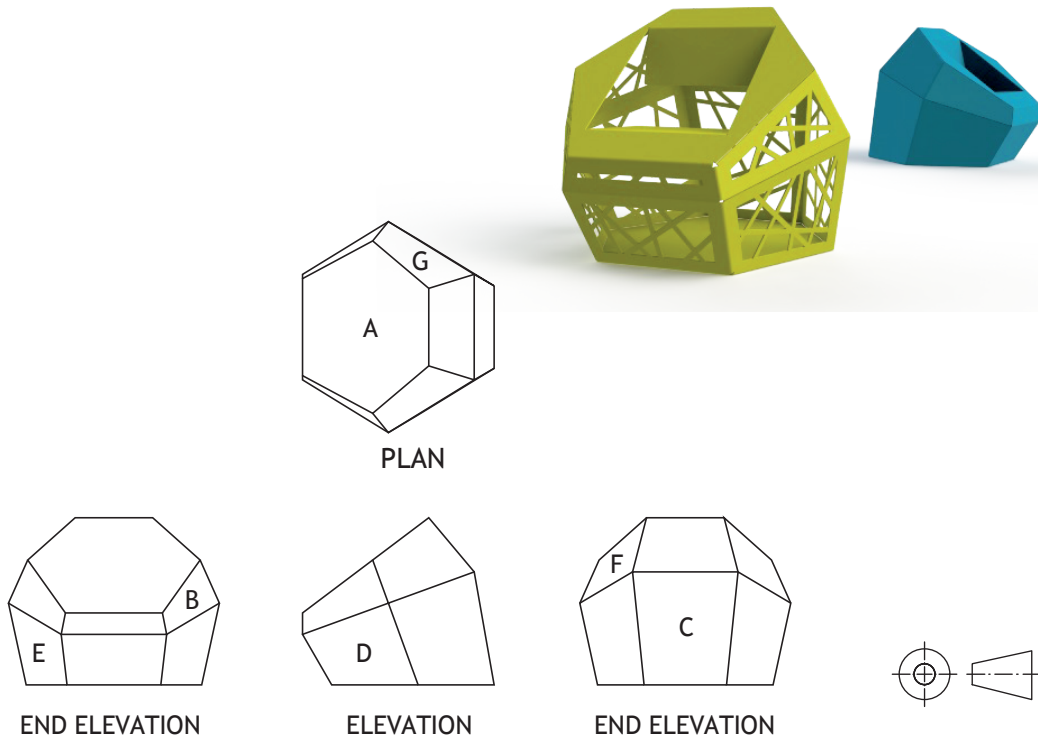

- (d) Indicate the position of faces A–G on the surface development below.
The surface development is shown from the **outside**.

7

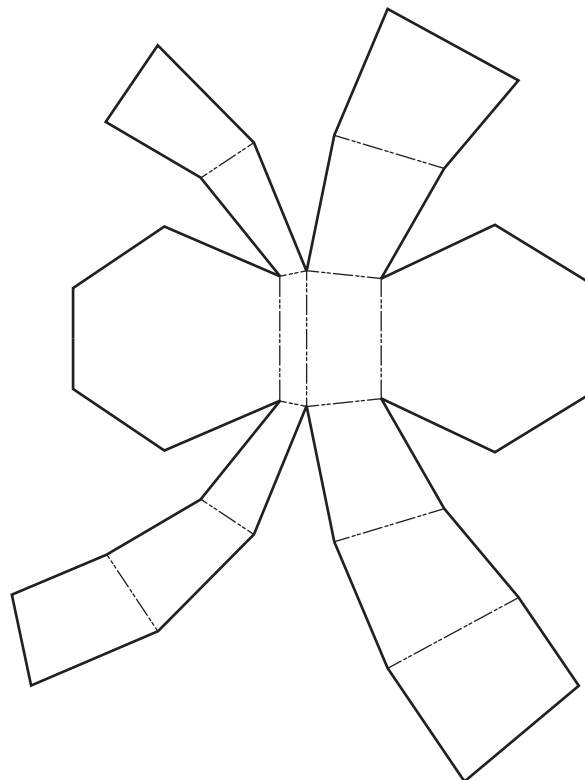

4. A digital, online, version of a travel magazine is being developed. A graphic artist has created a new layout for it.

You must use the graphic provided on the supplementary sheet for use with question 4 to answer this question.

(a) Describe how the graphic artist has created **balance** throughout the layout. 2

(b) Describe the effect that the graphic artist's use of **white space** has created within the layout. 2

(c) Describe how **shape** has been used to enhance the layout. 2

(d) Describe how **transparency** has been used to enhance the layout. 2



4. (continued)

The graphic artist has used various types of cropping to edit the images used in the layout.

Image 2



original → cropped

Image 4



original → cropped

(e) State the name of the type of crop applied to the images above.

(i) Image 2 _____ 1

(ii) Image 4 _____ 1

(iii) Describe the effects that the two types of cropping have created within the layout. 2

[Turn over



4. (continued)

Placeholder text was used throughout the layout.



(f) Explain the advantage to the graphic artist of using placeholder text.

2



4. (continued)

The layout was produced in layers using DTP software.



(g) Describe two advantages to the graphic artist of using layers to produce the layout.

2

[Turn over



4. (continued)

The digitised travel magazine has been optimised for viewing across a range of devices.



(h) Explain two benefits to consumers of reading the travel magazine online.

2

[END OF QUESTION PAPER]



MARKS DO NOT
WRITE IN
THIS
MARGIN

ADDITIONAL SPACE FOR ANSWERS



* X 8 3 5 7 6 0 1 2 5 *

MARKS DO NOT
WRITE IN
THIS
MARGIN

ADDITIONAL SPACE FOR ANSWERS



* X 8 3 5 7 6 0 1 2 6 *

[BLANK PAGE]

DO NOT WRITE ON THIS PAGE



* X 8 3 5 7 6 0 1 2 7 *

[BLANK PAGE]

DO NOT WRITE ON THIS PAGE

Acknowledgement of copyright

Question 4 <https://www.pexels.com/photo/woman-wearing-red-and-gold-kimono-2918482/>
<https://www.pexels.com/photo/person-holding-brush-drawing-kanji-script-1498273/>
<https://www.pexels.com/photo/japanese-lucky-coin-cat-932261/>
<https://www.pexels.com/photo/grayscale-photography-of-people-walking-towards-torigate-96931/>
<https://www.pexels.com/photo/red-umbrella-707673/>
<https://www.pexels.com/photo/app-business-connection-device-221185/>
<https://pixabay.com/photos/paper-white-grey-handmade-1332019/>

