



Higher  
Coursework  
Assessment Task



# Higher Graphic Communication Assignment Assessment Task

Valid for session 2022-23 only.

**This assessment is given to centres in strictest confidence. You must keep it in a secure place until it is used.**

This edition: January 2023 (version 2.0)

© Scottish Qualifications Authority 2023

# Contents

Introduction	1
Instructions for teachers and lecturers	2
Instructions for candidates	6

# Introduction

This document contains instructions for teachers and lecturers, and instructions for candidates for the Higher Graphic Communication assignment.

This is one of two course assessment components. The other component is a question paper.

To support teachers, lecturers and candidates, the modifications to the assignment that were in place for session 2021-22, which we reiterate below, remain in place for session 2022-23.

We have published the assignment in December 2022 rather than at the end of January 2023.

Existing assessment conditions (the assignment must be conducted under a high degree of supervision and control) remain in place, with the additional guidance from last session:

- ◆ Candidates can work on the assignment at home if necessary – for example, if a centre is temporarily closed. Where possible, adhere to the published conditions of assessment to maintain the reliability and validity of the evidence generated.
- ◆ Candidates can spend additional time on the assignment if necessary – for example, if a centre is temporarily closed. Use professional judgement to decide if additional time is necessary, as the assignment is designed to be completed in 8 hours. Spending more time on it could affect candidates' ability to cover all the learning required for the course and prepare for the question paper.

# Instructions for teachers and lecturers

You must conduct the assignment under a high degree of supervision and control. This means:

- ◆ candidates must be within your direct sight
- ◆ candidates must not interact with each other
- ◆ candidates must not have access to email, the internet and mobile phones
- ◆ candidates must complete their work independently – no group work is permitted
- ◆ classroom display materials that might provide assistance must be removed or covered
- ◆ with no interruption for learning and teaching
- ◆ in a classroom environment

## Time

Candidates have 8 hours to complete the assignment, starting at an appropriate point in the course after all content has been delivered. Once candidates begin, they must continue in each subsequent class period until the permitted time allocation has been used up.

You have a responsibility to manage candidates' work, distributing it at the beginning and collecting it at the end of each session, and storing it securely in between. This activity does not count towards the total time permitted for candidates to complete the assignment.

## Resources

This is a closed-book assessment. Candidates must not have access to learning and teaching materials, the internet, notes, exemplar materials, resources on classroom walls or anything similar.

There may be instances where restriction of internet and/or network use is prohibited (for example, if you have a local authority-managed network with specific limitations or CAD software that is web-based). However, it remains your professional responsibility to make every effort to meet the assessment conditions.

Each assessment task includes instructions and details of any equipment or materials required. Candidates can also use normal classroom equipment, software and hardware (such as drawing instruments, CAD and DTP software, and PCs to run the software) to complete the tasks.

Candidates can use a pre-made or existing A3 CAD template.

## Reasonable assistance

Candidates must progress through each stage of the assignment without your intervention or guidance, having acquired the skills earlier in the course.

Once candidates complete the assignment, you must not return it to them for further work. You must not provide feedback to candidates or offer an opinion on the perceived quality or completeness of the assignment response, at any stage.

You can provide reasonable assistance to support candidates with the following aspects of their assignment:

- ◆ printing, collating, stapling and labelling their evidence to ensure it is in the format specified by SQA
- ◆ ensuring candidates have all the materials and equipment required to complete the assignment
- ◆ understanding the information outlined in these instructions

## Evidence

All candidate evidence (whether created manually or electronically) must be submitted to SQA in a paper-based format.

Each task details what evidence is required and how many pages are expected. This is a guide to ensure that candidates do not produce too much work or spend too long on a single task. Single-sided A3 pages are preferred and are typically the most suitable for the tasks; however, it is acceptable to submit A4 pages if an A3 printer is not available.

Each piece of work must be labelled with the task number, for example, task 3a, and the back of each page must be clearly labelled with candidate details.

## Alteration or adaptation

You must not alter, adapt or modify the assignment in any way. This includes moving the content of the assignment into a different format or workbook. All candidates must undertake the assignment exactly as it is provided.

## Volume

Candidates should present their work on a maximum of 10 single-sided A3-sized pages.

This figure is given to indicate the volume of evidence required; however, no penalty is applied where candidates exceed this. Full details of evidence requirements are contained within each assessment task.

## Specific instructions for teachers and lecturers

You must follow these specific instructions. You must ensure that candidates are aware of the assessment conditions and know what they should do for each task.

Prior to candidates starting the assignment, you must download the following electronic files for their use. You must keep these files secure and candidates must not access them prior to assessment.

- ◆ data sheet 1 – graphic of a table number
- ◆ data sheet 7 – two-fold menu template
- ◆ data sheet 8 – copy text
- ◆ data sheet 9 – graphic of a company logo
- ◆ data sheet 9 – graphic of Background image 1 - colour gradient
- ◆ data sheet 9 – graphic of Background image 2 - wooden panels
- ◆ data sheet 9 – graphic of Background image 3 - grey wooden panels
- ◆ data sheet 9 – graphic of Background image 4 - brickwork
- ◆ data sheet 9 – graphic of Café image 1 - cappuccino being poured
- ◆ data sheet 9 – graphic of Café image 2 - two espresso cups
- ◆ data sheet 9 – graphic of Café image 3 - coffee and laptop
- ◆ data sheet 9 – graphic of Café image 4 - coffee, phone and notepad
- ◆ data sheet 9 – graphic of Café image 5 - cappuccino
- ◆ data sheet 9 – graphic of Café image 6 - café
- ◆ data sheet 9 – graphic of Café image 7 - cupcake
- ◆ data sheet 9 – graphic of Café image 8 - lemon and lime cake
- ◆ data sheet 9 – graphic of Café image 9 - chocolate fudge cake
- ◆ data sheet 9 – graphic of Café image 10 - pancake stack
- ◆ data sheet 9 – graphic of Café image 11 - bowl of soup
- ◆ data sheet 9 – graphic of Café image 12 - sandwich
- ◆ data sheet 10 – STEP files of walls and a floor, a table, a chair and a cup

This assignment has three tasks. Candidates must complete the tasks in order.

Each task has a notional time allocated to it.

### Task 1 – 21 marks

(suggested time 3 hours and 30 minutes)

- ◆ Tasks a to d: production drawings must be produced electronically and generated from a 3D CAD model produced by the candidate.

**Task 2 – 23 marks**

(suggested time 3 hours and 30 minutes)

- ◆ Task 2a: must be completed electronically. Candidates must identify where they have used the design principles **rhythm** and **alignment**. Candidates must also label where they have used two other principles or elements from the following list: shape, texture, value, balance or white space.
- ◆ Task 2b: must be completed electronically.

**Task 3 – 6 marks**

(suggested time 1 hour)

- ◆ Candidates are expected to complete this task manually. If they use an electronic method, it must not be 3D CAD software. Candidates will gain no marks if this software is used. If candidates use electronic sketching software, they are only permitted to use a straight edge. No other tools are permitted.

Note: candidates must not trace drawings for any part of the assignment. They will gain no marks for traced drawings.

All electronically generated evidence must be printed and compiled for uplift by SQA.

# Instructions for candidates

This assessment applies to the assignment for Higher Graphic Communication.

It assesses the following skills, knowledge and understanding:

- ◆ creativity when responding to graphic design tasks and situations
- ◆ using graphic communication technologies to meet a purpose
- ◆ producing preliminary, production and promotional graphic items in response to a situation or problem
- ◆ applying illustration and presentation techniques to create graphics with relevant visual impact
- ◆ producing 2D and 3D production drawings, applying appropriate standards, protocols and conventions
- ◆ producing promotional graphic publications to meet an agreed content and style
- ◆ reviewing and evaluating your progress, giving justification for your choice of graphic items and the graphic communication techniques employed

Note: you must not trace drawings for any part of the assignment – you will gain no marks for traced drawings.

In this assessment, you have to produce a range of graphics in response to a brief:

- ◆ in the order presented
- ◆ which assess aspects of the skills and knowledge listed above
- ◆ in 8 hours, excluding the time needed to set up and clear away any equipment, and for any printing that is required

**You must not use any text, images or other items from any other source unless you create them during this 8-hour assignment.**

There are three tasks, with marks allocated as follows:

**Task 1 – 21 marks: producing production drawings for a menu, salt and pepper holder**  
(suggested time 3 hours and 30 minutes)

**Task 2 – 23 marks: producing promotional graphics for a refurbished café**  
(suggested time 3 hours and 30 minutes)

**Task 3 – 6 marks: producing preliminary graphics for a takeaway drinks box proposal**  
(suggested time 1 hour)

Your teacher or lecturer will provide you with:

- ◆ tasks sheets 1 to 3
- ◆ data sheets 1 to 12
- ◆ STEP files of walls and a floor, a table, a chair and a cup
- ◆ electronic files of the graphics shown in data sheets 1 and 9

## Assessment conditions

This is a closed-book assessment. You must undertake the assignment under a high degree of supervision and control. This means:

- ◆ you must be within direct sight of your teacher or lecturer
- ◆ you must not interact with other candidates
- ◆ you must not have access to email, the internet and mobile phones
- ◆ you must complete your work independently – no group work is permitted

You have 8 hours to complete the assignment. Once you begin, you must continue in each subsequent class period until the permitted time allocation has been used up.

## Reasonable assistance

You must progress through each stage of the assignment without intervention or guidance from your teacher or lecturer.

Once you have completed the assignment, it will not be returned to you for further work. You will not be provided with feedback on the perceived quality or completeness of the assignment response at any stage.

You can be provided reasonable assistance to support with the following aspects of your assignment:

- ◆ printing, collating, stapling and labelling your evidence to ensure it is in the format specified by SQA
- ◆ ensuring you have all the materials and equipment required to complete the assignment
- ◆ understanding the information outlined in these instructions

## Submitting your work

You must label each piece of evidence with the task number (for example task 1a), and the back of each page with your:

- ◆ name
- ◆ date of birth
- ◆ Scottish Candidate Number (SCN)
- ◆ centre name
- ◆ centre number

## Graphic Communication brief

A café in Aviemore is being refurbished. As part of the refurbishment, the café owners have requested a range of graphics for a new two-fold menu and a menu, salt and pepper holder. The café owners have asked you to create:

- ◆ production drawings to manufacture the menu, salt and pepper holder
- ◆ a new two-fold menu design, with relevant desktop published graphics

You have been provided with:

- a company logo and colours
- copy text
- several pre-approved promotional images

Note: you cannot alter the company name, logo or company colours

- ◆ a 3D illustrated environment that showcases a single table set-up
- ◆ preliminary sketches of a takeaway drinks box

Use the data sheets provided to guide you through the assignment.

# Task 1: menu, salt and pepper holder

A CAD technician has prepared a series of draft CAD drawings to help with the manufacture of the menu, salt and pepper holder.

Using the draft CAD drawings and information on data sheets 1, 2, 3, 4, 5 and 6, model the menu, salt and pepper holder components using 3D CAD software.

From these models, produce production drawings based on the menu, salt and pepper holder shown.

You may use top-down modelling or bottom-up modelling in your work.

When completing task 1, all drawings must:

- ◆ be produced in the same orientation as the given orthographic views on each individual data sheet
- ◆ have correctly labelled views with an appropriate font size
- ◆ include the following British Standard conventions:
  - linear (parallel and chain as appropriate), radial, diameter and angular dimensions
  - the third angle projection symbol, where appropriate
  - a title block including relevant information
- ◆ include hidden detail, appropriate dimensions for manufacture, and annotations, unless stated

1a (i) Produce an elevation, a plan and an end elevation of the base (part 1). All views must be produced at a scale of 1:1.

Your drawing must include a detail view of one of the bosses from the plan view.

**(5 marks)**

(ii) Produce an elevation, a plan and an end elevation of the salt and pepper top (part 3). All views must be produced at a scale of 2:1.

Your drawing must include:

- ◆ three related views of the salt and pepper top (part 3)
- ◆ an auxiliary plan at a scale of 2:1 of surface X, showing the true shape of surface X shown on data sheet 5
- ◆ an enlargement view of one of the repeated semi-circles taken from the plan
- ◆ a minimum of one dimension on the enlargement view

**(6 marks)**

1b Produce a drawing of the assembled menu, salt and pepper holder as shown on data sheet 2.

Your drawing must include:

- ◆ a plan
- ◆ a sectional elevation through cutting plane X
- ◆ a stepped-sectional end elevation through cutting plane Y of the menu, salt and pepper holder. The sectional view may show the web either hatched or unhatched
- ◆ an enlargement view to show how the salt and pepper bottom (part 2) and the salt and pepper top (part 3) fit together

The three orthographic views must be produced at a suitable scale and must be assembled as shown on data sheet 2.

**Do not include dimensions or hidden detail.**

**(5 marks)**

1c Produce an exploded isometric view of the assembled menu, salt and pepper holder from task 1b.

- ◆ Do not show hidden detail.
- ◆ You must produce the view as a line drawing.
- ◆ You must not render the exploded isometric view.

**(2 marks)**

1d Include British Standard conventions in all of your drawings.

**(3 marks)**

**Note:** you must create all the production drawings for task 1 electronically and print out all your work.

You should complete task 1 on four or five single-sided A3-sized pages.

You should spend approximately 3 hours and 30 minutes on task 1.

Your completed assignment (tasks 1 to 3) should be on no more than 10 single-sided A3-sized pages.

## Task 2: promotional graphics

As part of the café refurbishment an updated two-fold menu and a new table set-up is being proposed.

Data sheets 1, 7, 8, 9 and 10 contain information on the proposed two-fold menu design and the 3D computer rendered environment of the table set-up.

The café owners have asked you to create:

- ◆ relevant graphics for a two-fold menu, which effectively promotes the company. You have been provided with:
  - a company logo and colours
  - copy text
  - several pre-approved promotional images)

Note: you cannot alter the company name, logo or company colours

- ◆ a 3D computer rendered environment of the new table set-up, which includes the assembled menu, salt and pepper holder you created in task 1

Produce promotional graphics, using the information on data sheets 1, 7, 8, 9 and 10.

- 2a Produce a **full-size** version of a desktop published two-fold menu using data sheets 7, 8 and 9, that demonstrates your skill in the use of design elements and principles and has a high level of visual impact.

You must use the file ‘**two-fold menu template**’ provided to ensure the correct layout shape is created.

Your layout must include:

- ◆ the design principles **rhythm** and **alignment**. You must include appropriate annotations to identify where you have used both of your design principles
- ◆ two design principles or elements from the following list: shape, texture, value, balance or white space. You must include appropriate annotations to identify where you have used your chosen design principles or elements
- ◆ effective use of the desktop publishing techniques **pull quote** and **cropping (square or full)**. You must include appropriate annotations to identify where you have used both desktop publishing techniques
- ◆ the company logo from data sheet 9 on panel B2
- ◆ effective use of two contrasting fonts
- ◆ one background image from data sheet 9 on panel B2
- ◆ a minimum of three CMYK colours from data sheet 7 (this must include CMYK colour 1 used on panel A2, as shown on data sheet 7)
- ◆ at least two café images from data sheet 9

You can add other graphic items as long as you create them within the 8 hours of this assignment.

You can use the images on data sheet 9 as they are, or you can edit them to suit your design.

(14 marks)

2b Using the assembled menu, salt and pepper holder you created in task 1, produce pictorial illustrations of your menu, salt and pepper holder sited on the table STEP file.

You must produce high-quality pictorial illustrations from **two** different viewpoints, similar to those shown on data sheet 10. These must be renders rather than screen grabs.

Your illustrations must be free from pixilation and grain. Your application of lighting must be high quality.

Each viewpoint should be printed on an individual landscape sheet and must be scaled to fit the entire page.

Your illustrations must include:

- ◆ the STEP files provided of the walls and floor, table, chair (x2) and cup (x2). These must be suitably scaled and similarly positioned to the locations illustrated on data sheet 10
- ◆ the menu, salt and pepper holder, suitably scaled and placed on the table STEP file, as highlighted on data sheet 10
- ◆ appropriate colours or materials to meet the specifications for each STEP file, as highlighted on data sheet 10
- ◆ appropriate colours or materials to meet the specifications for the menu, salt and pepper holder, as highlighted on data sheet 1
- ◆ a table number graphic decaled on to the menu, salt and pepper holder, as illustrated on data sheet 1
- ◆ appropriate wall and/or floor materials or colours that fit with the context of the café
- ◆ appropriate highlights and shadows applied to the scene

**(9 marks)**

You must produce task 2a electronically and print out all your work. You must also create all 3D computer renders for task 2b electronically and print out all your work.

You should complete task 2 on three or four single-sided A3-sized pages.

You should spend approximately 3 hours and 30 minutes on task 2.

Your completed assignment (tasks 1 to 3) should be on no more than 10 single-sided A3-sized pages.

## Task 3: takeaway drinks box

A CAD technician has prepared a draft CAD drawing of a proposed takeaway drinks box and a pictorial drawing of a travel mug.

This task assesses your sketching skills. Do not use a drawing board. If you measure, trace or use any drawing instruments other than a straight edge, you will gain no marks for this task.

You should complete this task manually. If you use an electronic method, it must not be 3D CAD software, you will gain no marks if this is used. If you use electronic sketching software, you are only permitted to use a straight edge. No other tools are permitted (for example, snapping tools, line and shape tools and colour fill tools).

- 3a Produce a preliminary **pictorial** sketch of the assembled takeaway drinks box using the information on data sheet 11.

Your pictorial sketch must:

- ◆ represent the takeaway drinks box shown in the draft CAD drawing on data sheet 11
- ◆ include one fully assembled drinks cup in the takeaway drinks box
- ◆ be presented taking note of the edge nearest the viewer

**You must not include colour, highlights or shadows.**

**(3 marks)**

- 3b Produce a preliminary **orthographic** sketch of the travel mug using the information on data sheet 12.

Your orthographic sketch must:

- ◆ accurately represent the travel mug shown on the pictorial drawing on data sheet 12
- ◆ include an elevation and a plan of the travel mug in the orientation highlighted on data sheet 12
- ◆ be produced in third angle projection

**You must not include colour, highlights or shadows. Do not include hidden detail or centre lines.**

**(3 marks)**

Note: if you complete task 3 electronically you must print out all your work.

You should complete task 3 on one or two single-sided A3-sized pages.

You should spend approximately 1 hour on task 3.

Your completed assignment (tasks 1 to 3) should be on no more than 10 single-sided A3-sized pages.

# Data sheet 1 – menu, salt and pepper holder components and decal

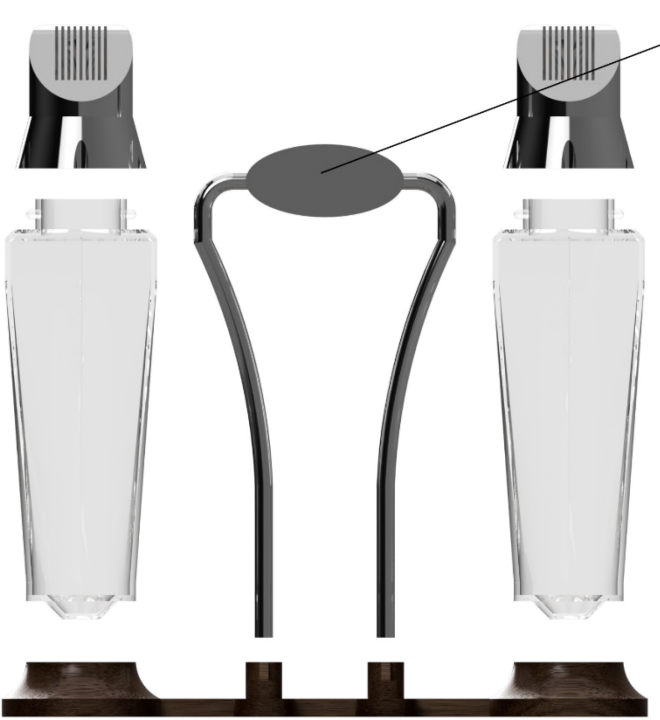

PARTS LIST			
PRT	QTY	NAME	MATERIAL
1	1	base	wood
2	2	salt and pepper bottom	transparent plastic or glass
3	2	salt and pepper top	metal
4	2	table number plate	metal

# Data sheet 2 – assembled menu, salt and pepper holder

## MENU, SALT AND PEPPER HOLDER

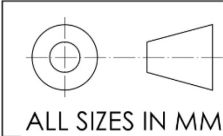

ALL SIZES IN MM  
NOT TO SCALE  
SOME CENTRE LINES REMOVED FOR CLARITY

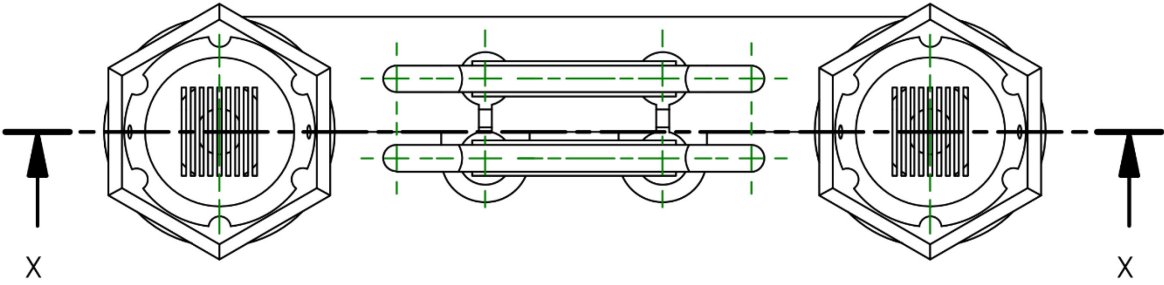

PLAN

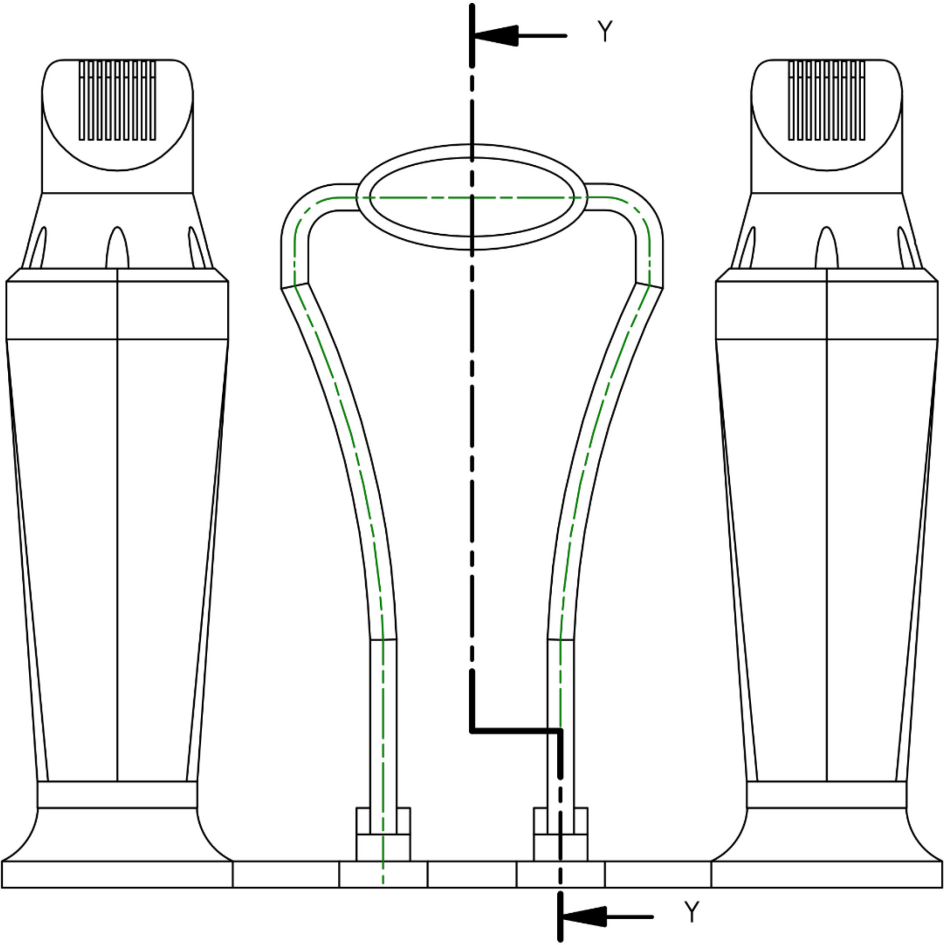

ELEVATION

# Data sheet 3 – base (part 1)

MENU, SALT AND PEPPER HOLDER

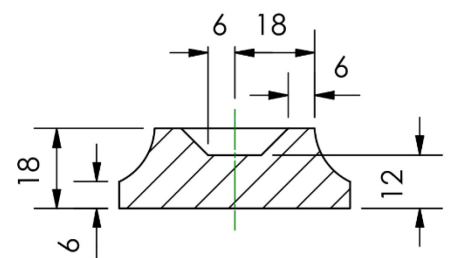
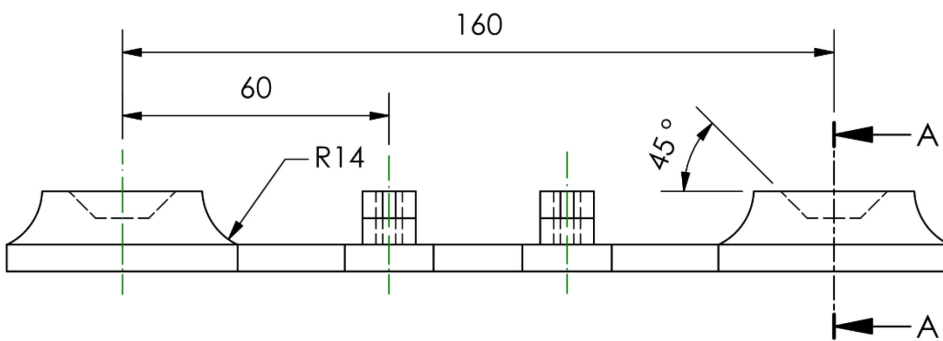
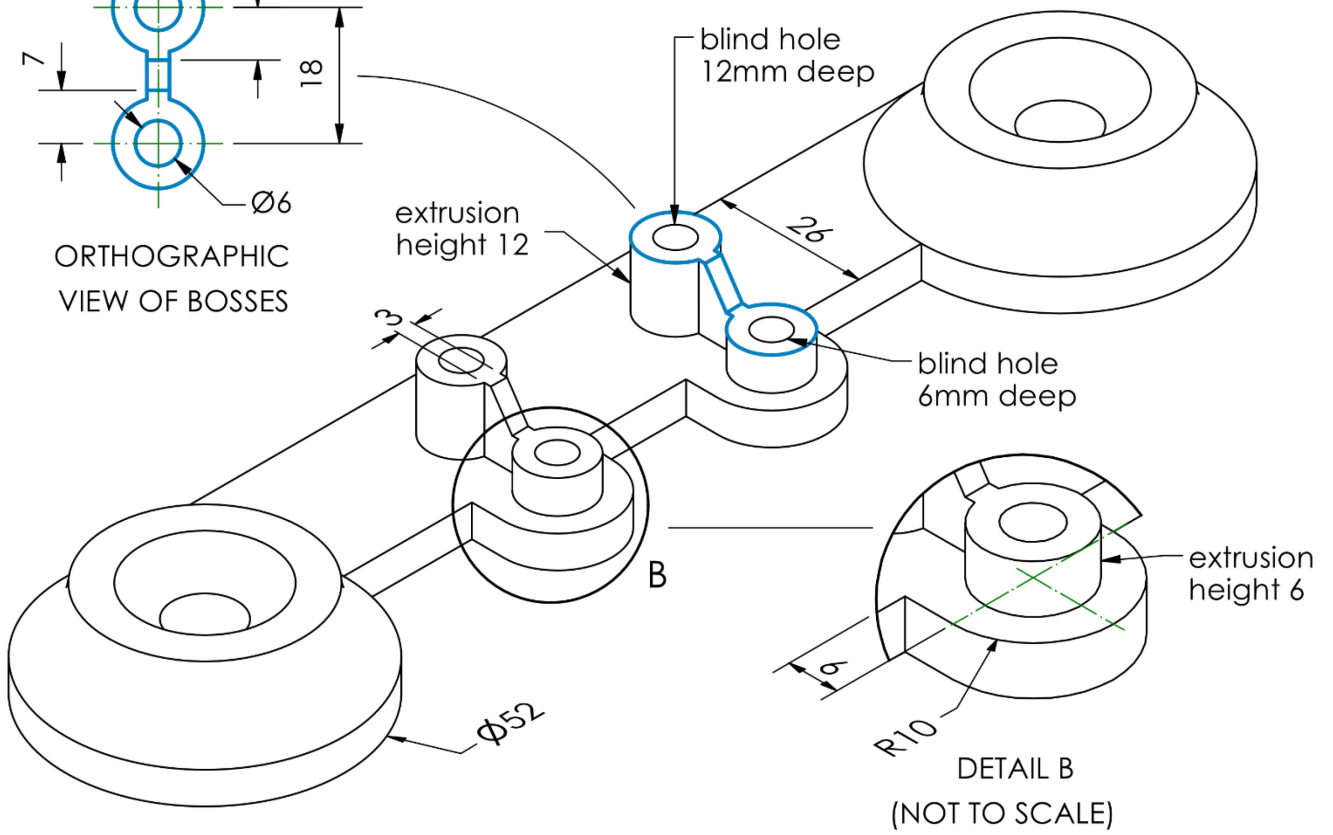
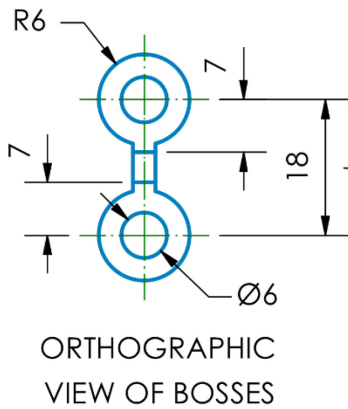
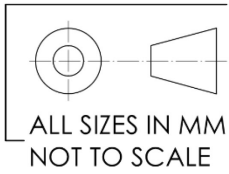

# Data sheet 4 – salt and pepper bottom (part 2)

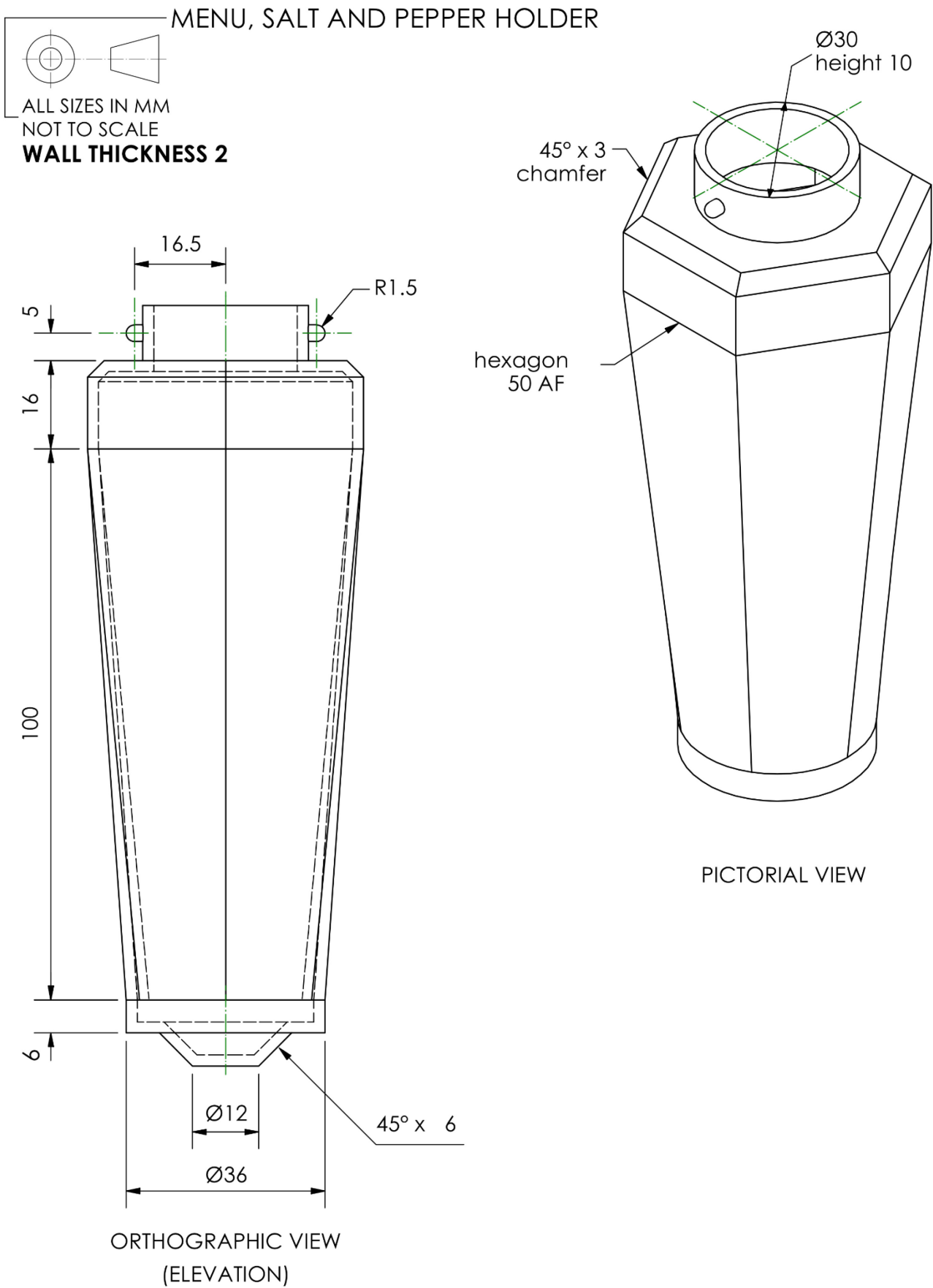

# Data sheet 5 – salt and pepper top (part 3)

MENU, SALT AND PEPPER HOLDER

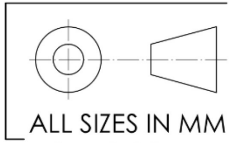

ALL SIZES IN MM  
NOT TO SCALE

**WALL THICKNESS 3.5**

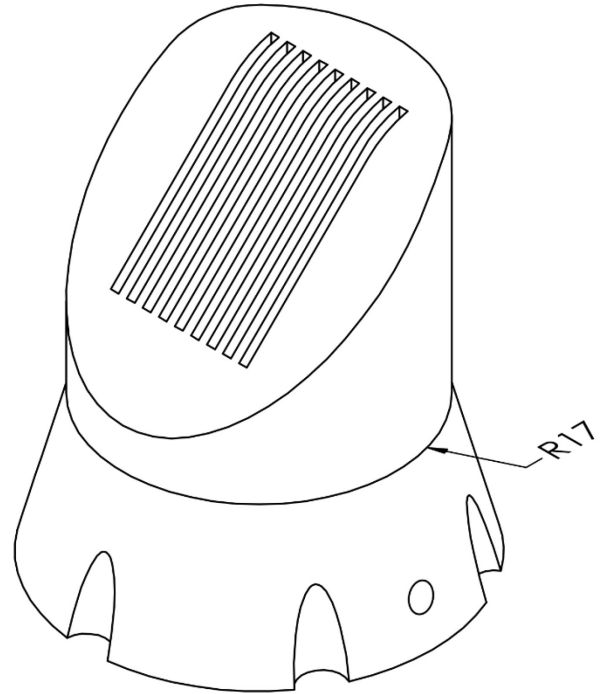
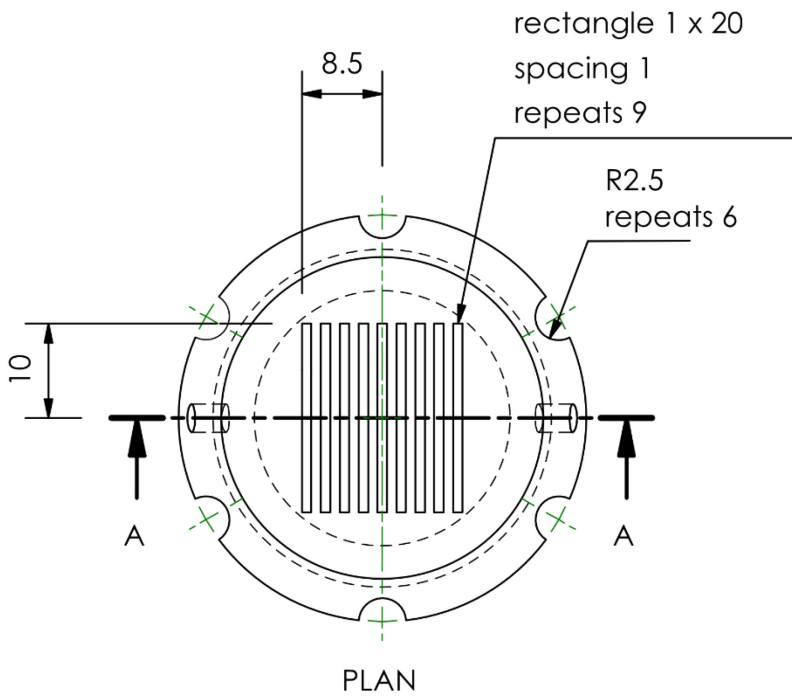

PICTORIAL VIEW

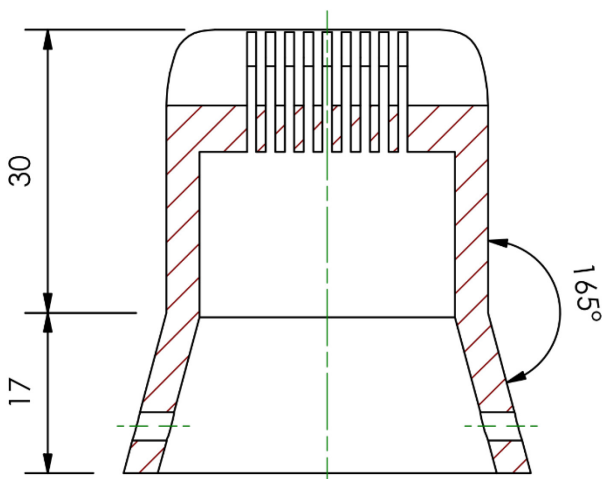

SECTION A-A

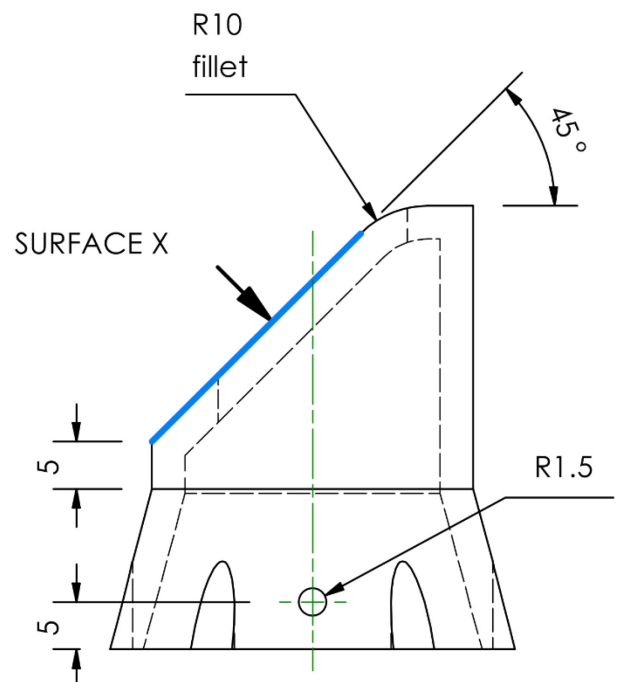

END ELEVATION

# Data sheet 6 – table number plate (part 4)

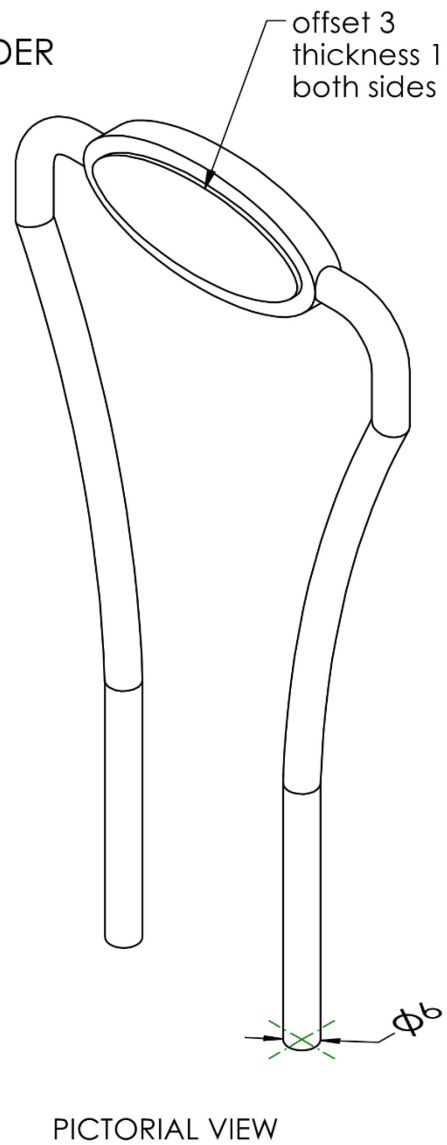
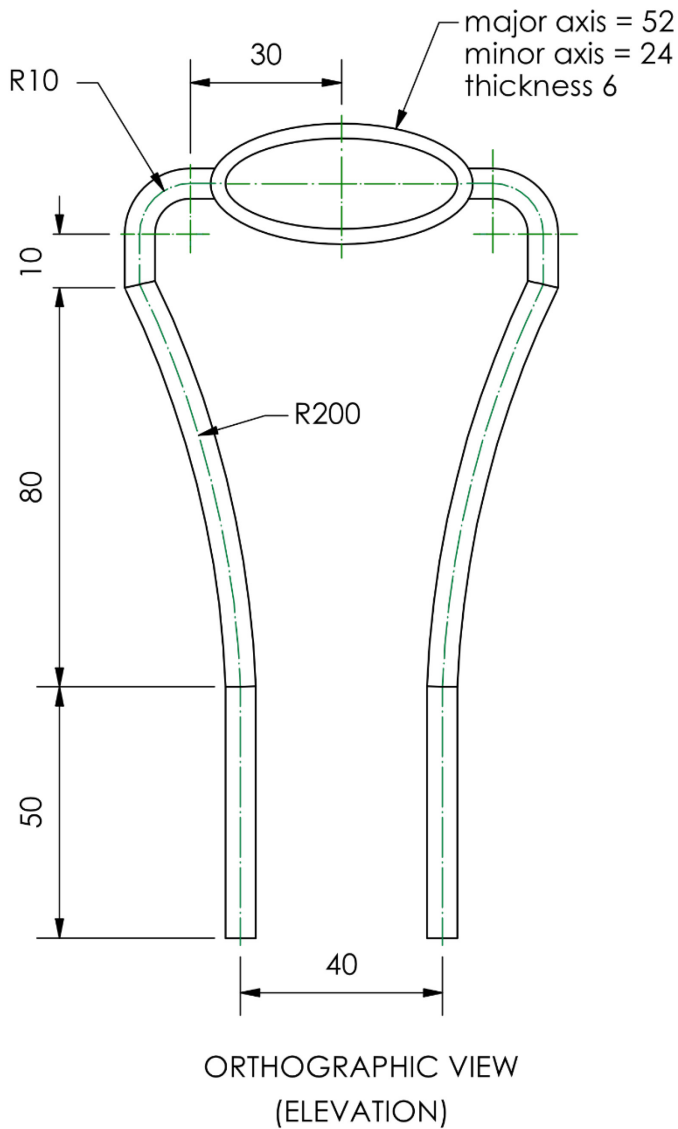
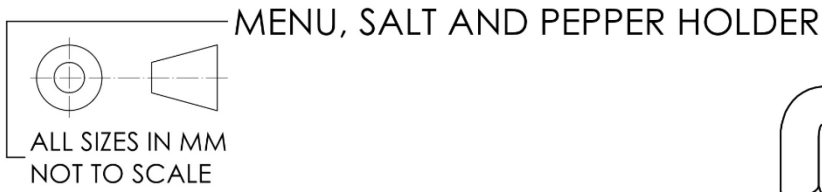

# Data sheet 7 – two-fold menu

## TWO-FOLD MENU

ALL SIZES IN MM  
NOT TO SCALE  
A template has been provided.

area must include  
CMYK colour 1

CMYK colours	
colour 1	C:57 M:0 Y:69 K:0
colour 2	C:37 M:0 Y:32 K:0
colour 3	C:73 M:58 Y:0 K:0
colour 4	C:26 M:0 Y:96 K:0

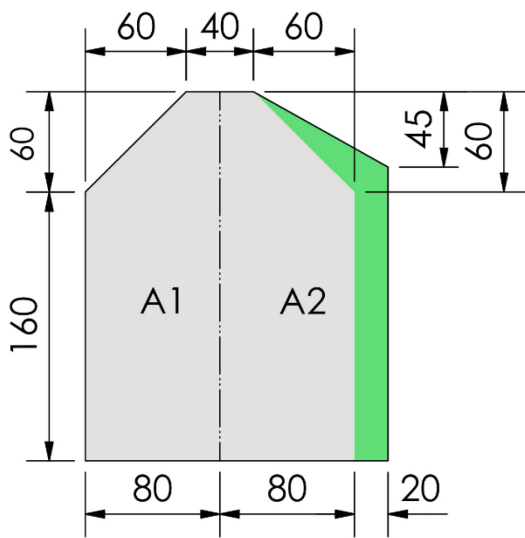
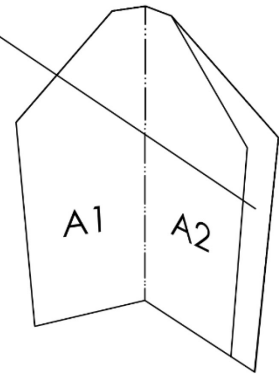

leaflet open  
(inside)

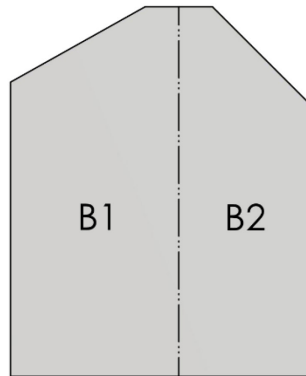

leaflet open  
(back)

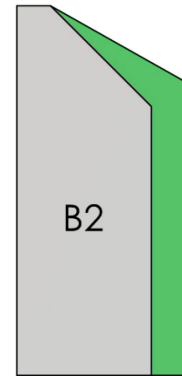

leaflet closed  
(front)

# Data sheet 8 – copy text

## Panel A1

*Subheading* – Sandwiches (gluten-free bread available)

Parma ham and mozzarella  
Chargrilled chicken  
Brie and bacon  
Coronation chickpea (VG)  
Roasted vegetables with vegan pesto (VG)

*Subheading* – Toasties (gluten-free bread available)

Tuna melt  
Cheese and onion (V)  
Mozzarella, tomato and pesto (V)

*Subheading* – Soups

Minestrone (V)  
Tomato and basil (VG)  
Scotch broth

*Subheading* – Breakfast

Bacon and fried egg breakfast roll  
Home-made granola with berries and Greek-style yogurt (VG)  
Croissant with jam and butter (V)  
Fluffy pancakes with maple syrup (VG)  
Smoked salmon bagel

*Footer* – vegetarian (V), vegan (VG)

## Panel A2

*Subheading* – Sweet bakery

Empire biscuit (VG)  
Strawberry tart (V)  
Fruit scone (V)  
Chocolate brownie (V)  
Millionaire's shortbread (V, gluten-free)  
Lemon and lime cake (VG)  
Red velvet cupcake (V)

*Footer* – vegetarian (V), vegan (VG)

## **Panel B1**

### *Subheading – Coffee*

Deiana's ristretto  
Espresso  
Americano  
Latte  
Cappuccino

### *Subheading – Tea*

Breakfast tea  
Lemon and ginger  
Peppermint  
Camomile  
Red berry

*Footer – Dairy-free alternatives available.*

### *Subheading – About us*

Deiana's Café is a family-run business based in Aviemore. Mario Deiana moved to Scotland in 1957 and opened a small bakery on Grampian Road in Aviemore. Since opening, the business has expanded and now Deiana's Cafés can be found in locations all across Scotland. The chain of cafés was recently described by local restaurant critic Jeremy Dempsie as, "An outstanding treat that won't be forgotten in a hurry!". Mario retired in 2003 but can still be seen occasionally indulging in his signature Deiana's ristretto coffee in the original Grampian Road café.

*Pull quote – An outstanding treat that won't be forgotten in a hurry!*

# Data sheet 9 – image bank

logo



include on panel B2

background images - one image to be used

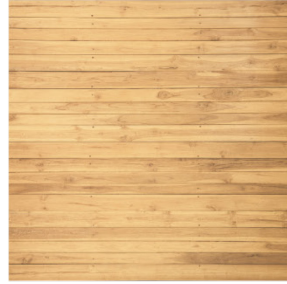
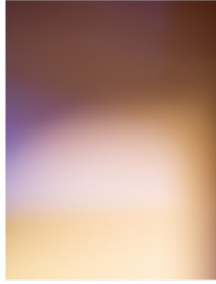

cafe images - minimum two images to be used



## Data sheet 10 – STEP files

Component	Material or colour
Walls and floor	Walls - white Floor - wooden flooring
Table	Table top - white Table and base and stand - polished metal
Chairs	Light blue plastic
Cups	Yellow
Menu, salt and pepper holder	See data sheet 1

**Landscape layout of viewpoint 1** - to show all models with correct materials or colours applied.

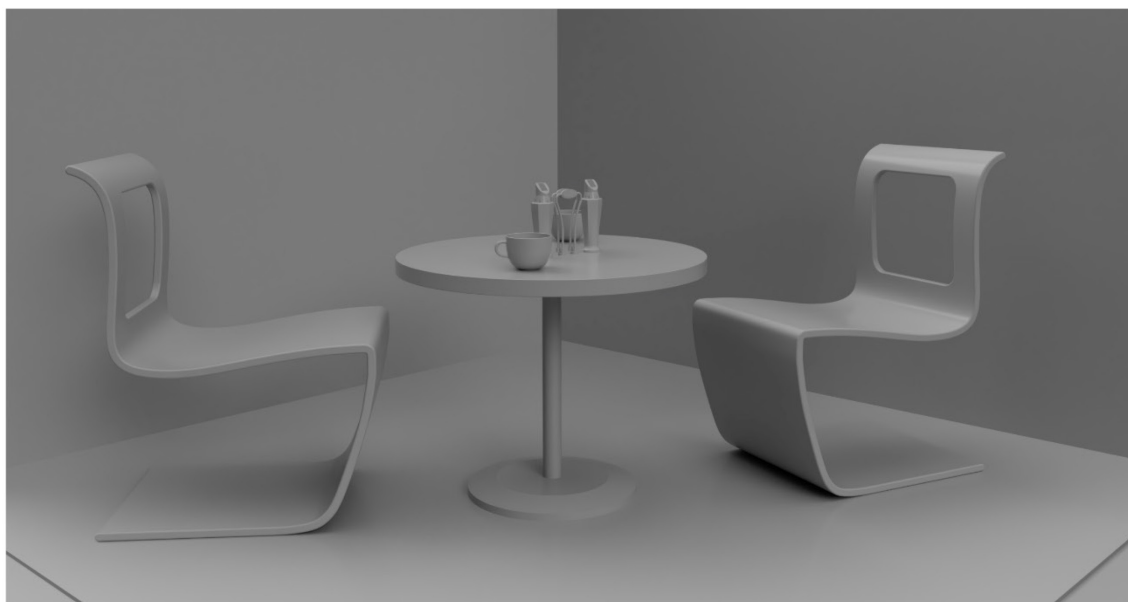

**Landscape layout of viewpoint 2** - to show candidate model with greater clarity and correct application of table number decal.

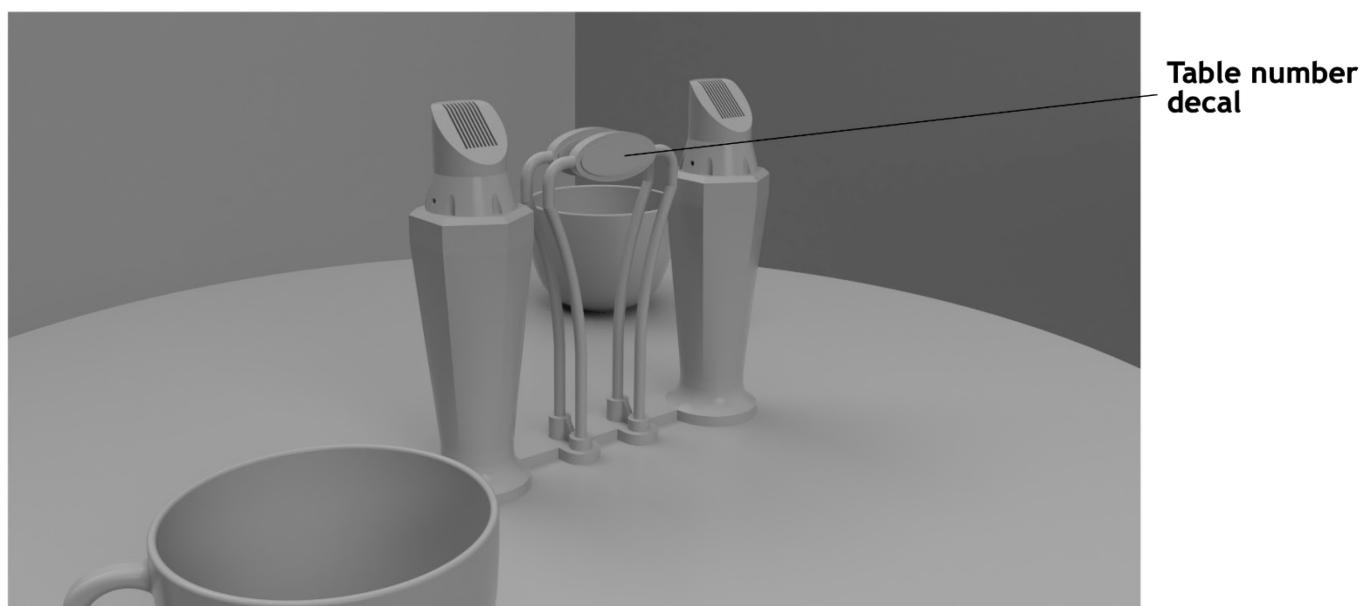

# Data sheet 11 – takeaway drinks box



NOTE: you do not need to show the thickness of the cardboard in your sketch

The takeaway drinks box is asymmetrical across the central axis when viewed from the elevation. Partial hidden detail has been included to aid clarity of the takeaway cup.

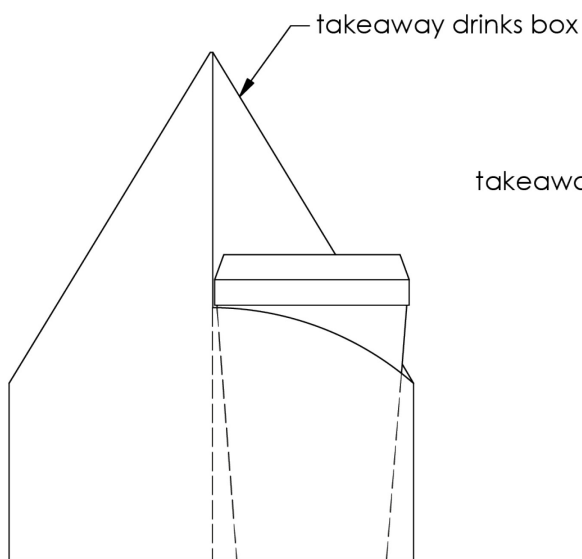
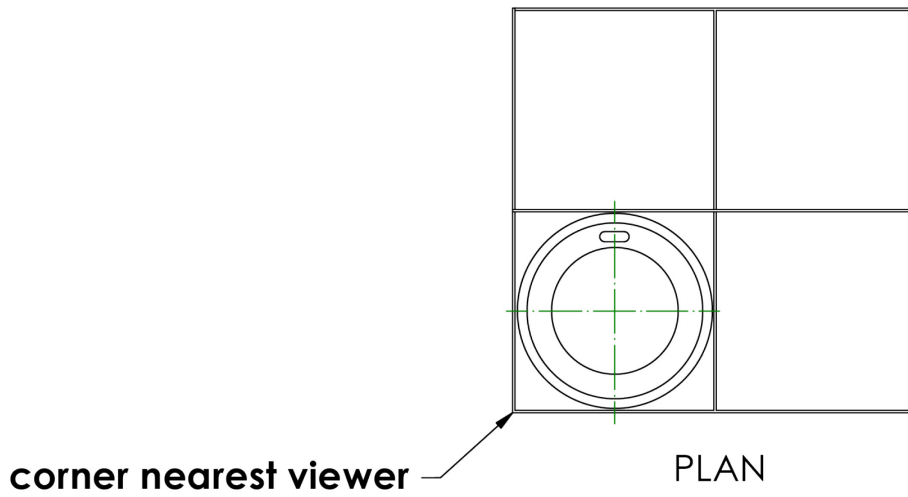

END ELEVATION

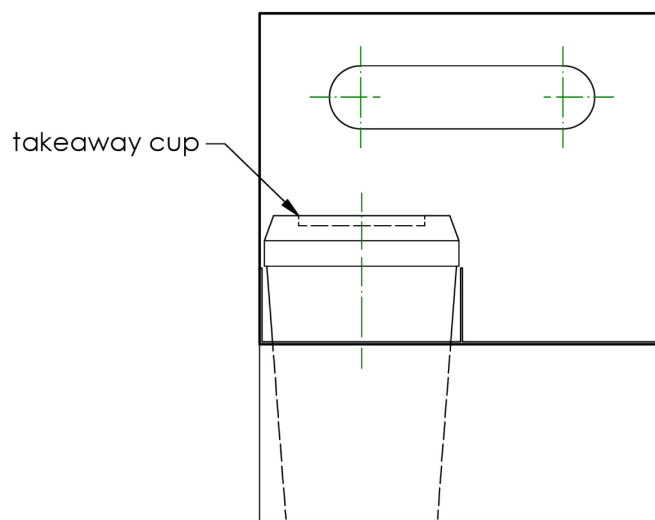

ELEVATION

# Data sheet 12 – travel mug

TRAVEL MUG  
NOT TO SCALE

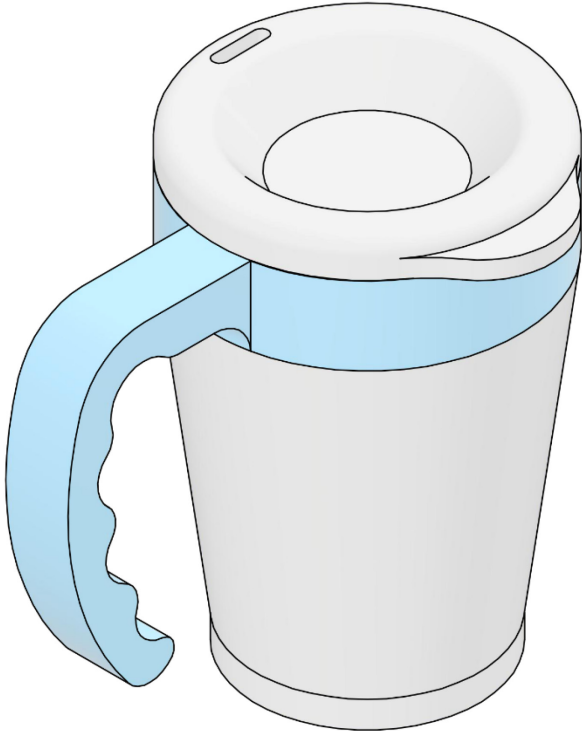
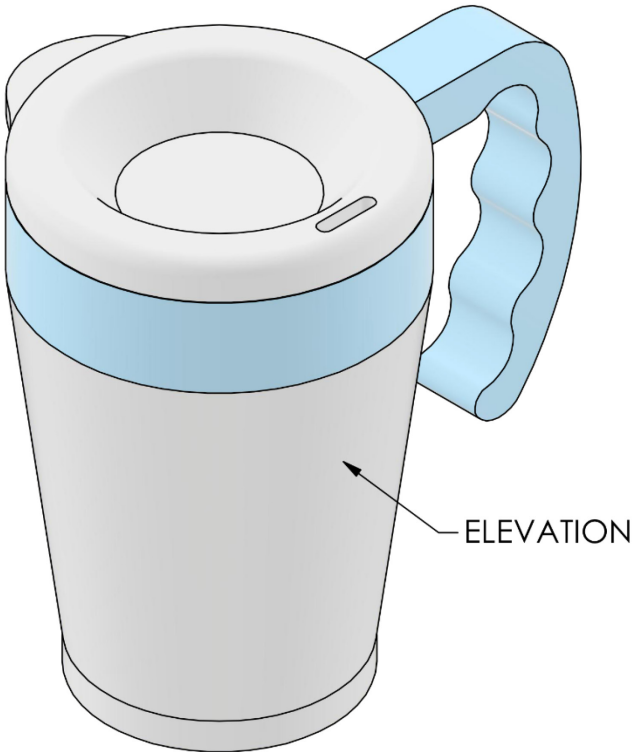

## Copyright acknowledgements

Data Sheet 9

All images are taken from Pexels - Creative Commons Zero Licence

Electronic Files

All images are taken from Pexels - Creative Commons Zero Licence

## Administrative information

---

Published: December 2022 (version 1.0)

---

### History of changes

Version	Description of change	Date
2.0	Change to Data Sheet 11	16/01/23

## Security and confidentiality

This document can be used by SQA approved centres for the assessment of National Courses and not for any other purpose.

This document may only be downloaded from SQA's designated secure website by authorised personnel.

© Scottish Qualifications Authority 2023