

FOR OFFICIAL USE



--	--	--	--	--	--

National  
Qualifications  
2023 MODIFIED

Mark

--

**X835/76/01**

**Graphic Communication**

THURSDAY, 11 MAY

1:15 PM – 3:15 PM



\* X 8 3 5 7 6 0 1 \*

Fill in these boxes and read what is printed below.

Full name of centre

--

Town

--

Forename(s)

--

Surname

--

Number of seat

--

Date of birth

Day

--	--

Month

--	--

Year

--	--

Scottish candidate number

--	--	--	--	--	--	--	--	--	--

**Total marks — 75**

Attempt ALL questions.

All dimensions are in mm.

All technical sketches and drawings use third angle projection.

You may use rulers, compasses or trammels for measuring.

In all questions you may use sketches and annotations to support your answer if you wish.

Write your answers clearly in the spaces provided in this booklet. Additional space for answers is provided at the end of this booklet. If you use this space you must clearly identify the question number you are attempting.

Use **blue** or **black** ink.

Before leaving the examination room you must give this booklet to the Invigilator; if you do not, you may lose all the marks for this paper.



\* X 8 3 5 7 6 0 1 0 1 \*

Total marks — 75  
Attempt ALL questions

1. 3D CAD modelling software was used to create the sub-assembly of the door handle shown below.
- (a) (i) Describe, using 3D CAD terms, how to constrain the three door handle components.
- You may annotate the drawings and use sketches to support your answer. 4

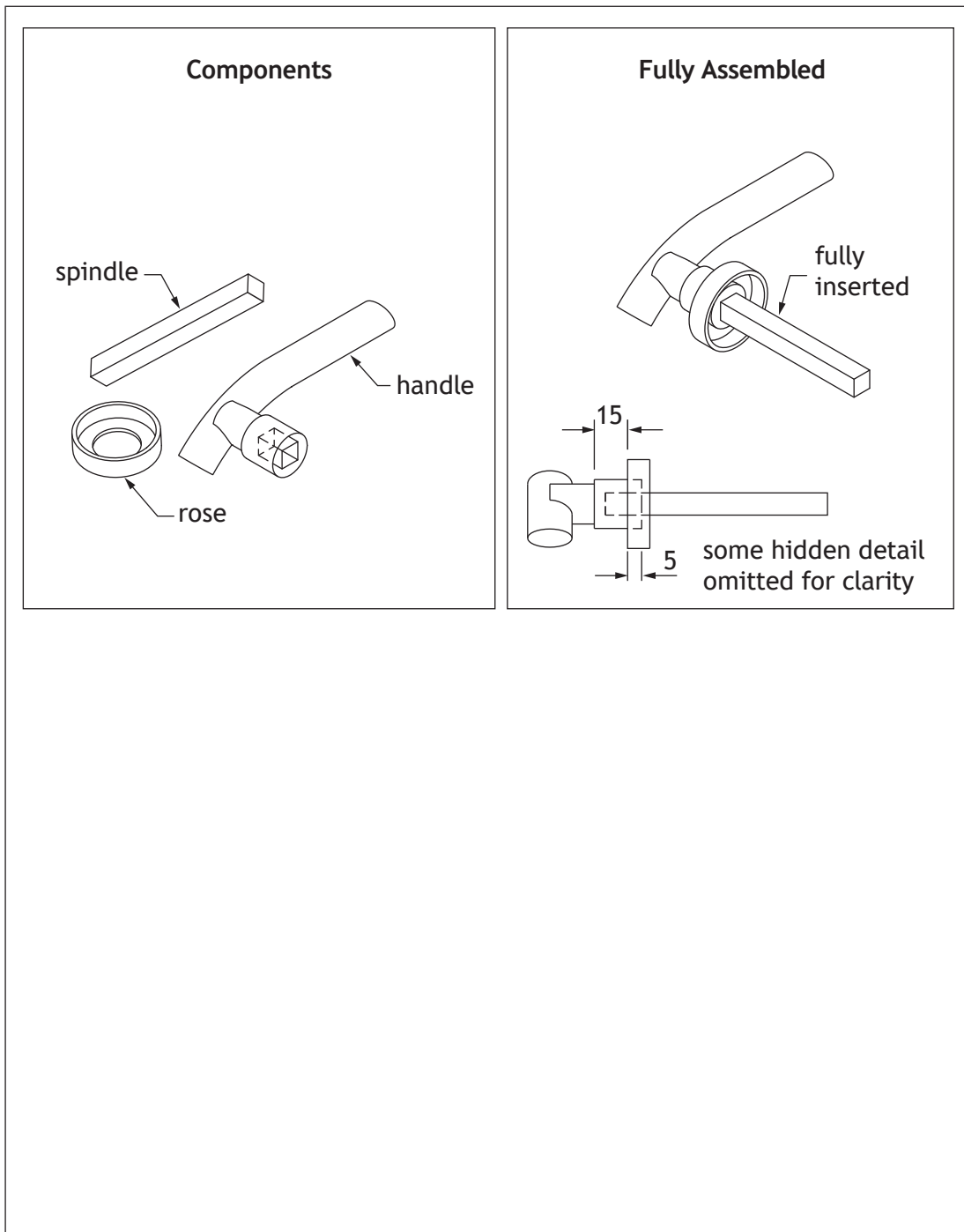

1. (a) (continued)

(ii) Explain the term sub-assembly.

1

---



---

The CAD technician used top-down modelling to model the sub-assembly components.

(iii) Describe **two** advantages to the CAD technician of using top-down modelling.

2

---



---



---



---

(b) You must use the drawing provided on the **supplementary sheet for use with question 1 (b)** to answer this question.

(i) State the name of sectional view X, shown on the elevation.

1

---

(ii) Explain the purpose of a detail view.

1

---



---

(iii) Describe, giving **two** reasons, the purpose of an exploded isometric view.

2

---



---



---



---



1. (continued)

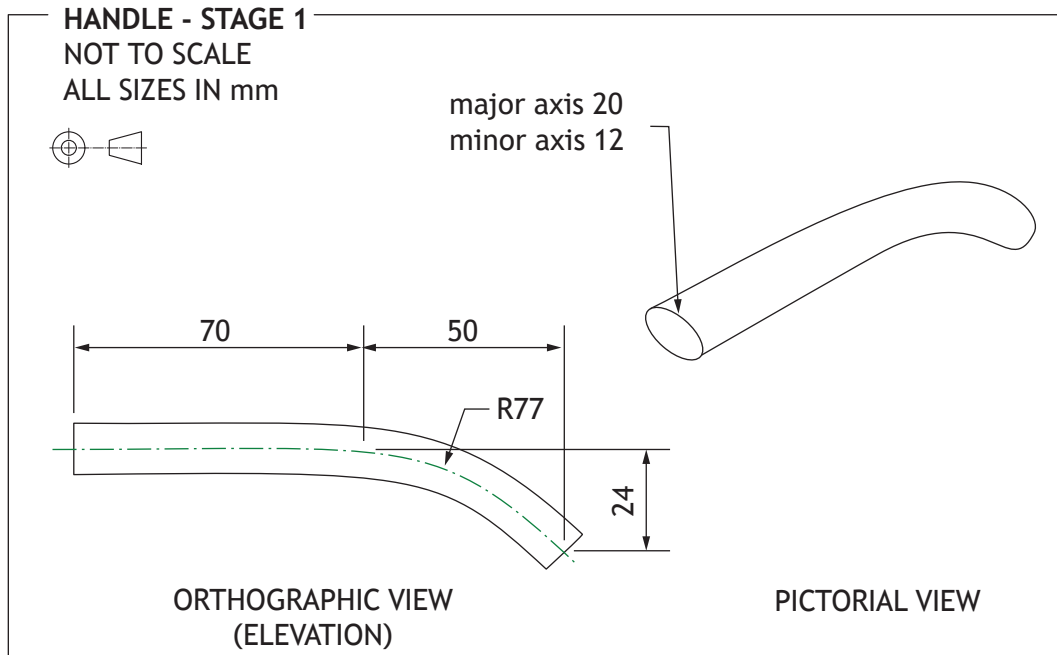

The CAD technician created the handle component in several stages. Dimensions for stage 1 of the 3D modelling process are provided on the working drawing above.

- (c) Describe, using CAD modelling techniques, how to create stage 1.  
 You must refer to the dimensions given in the drawing.  
 You may use sketches to support your answer.

3



2. Graphics for a toy are provided on the **supplementary sheets for use with question 2 (a)**.

(a) Describe the 3D CAD modelling techniques used to create the central support of the toy.

You must refer to the dimensions given on the **supplementary sheets for use with question 2 (a)**.

You may use sketches to support your answer.

8

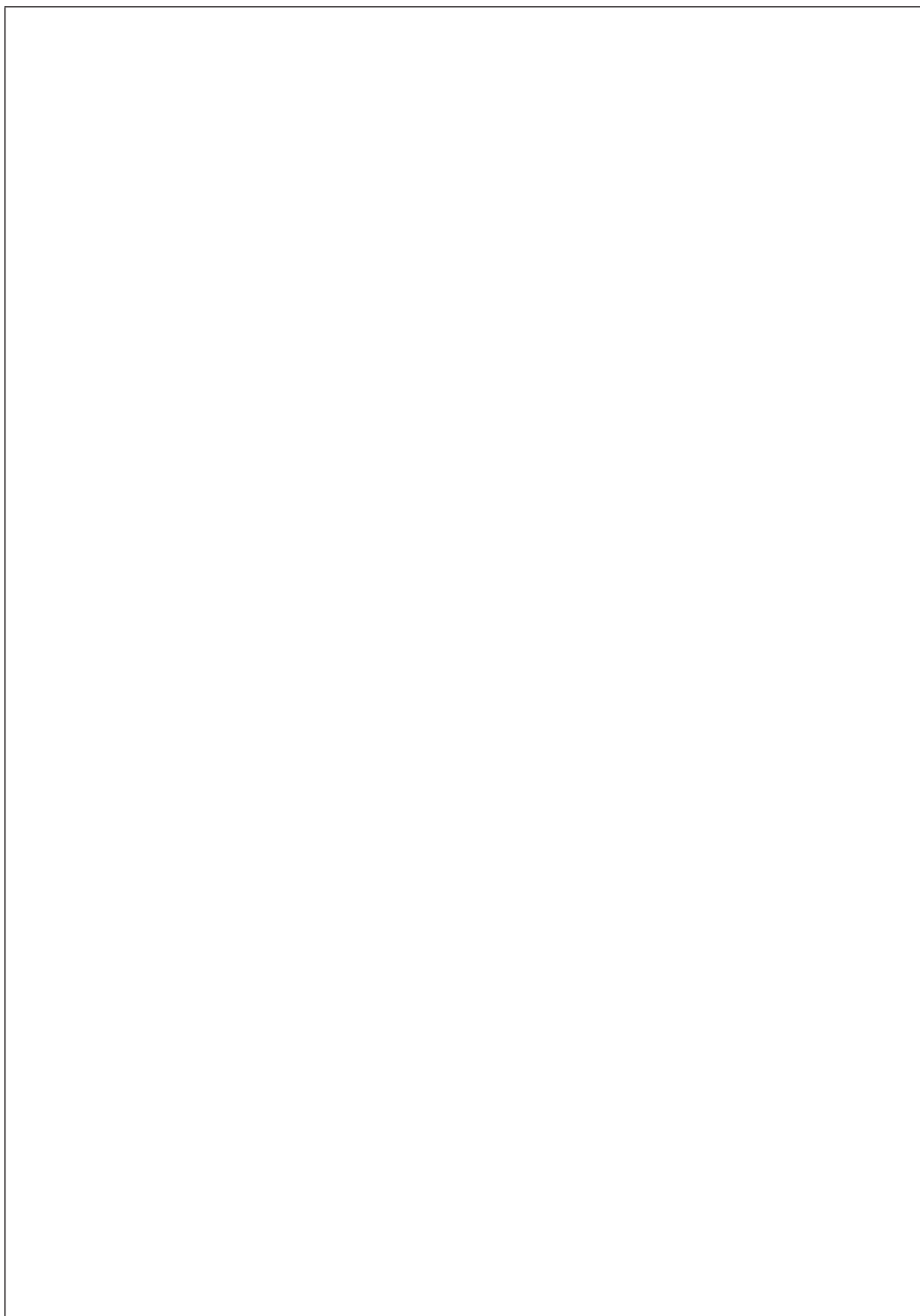

2. (continued)

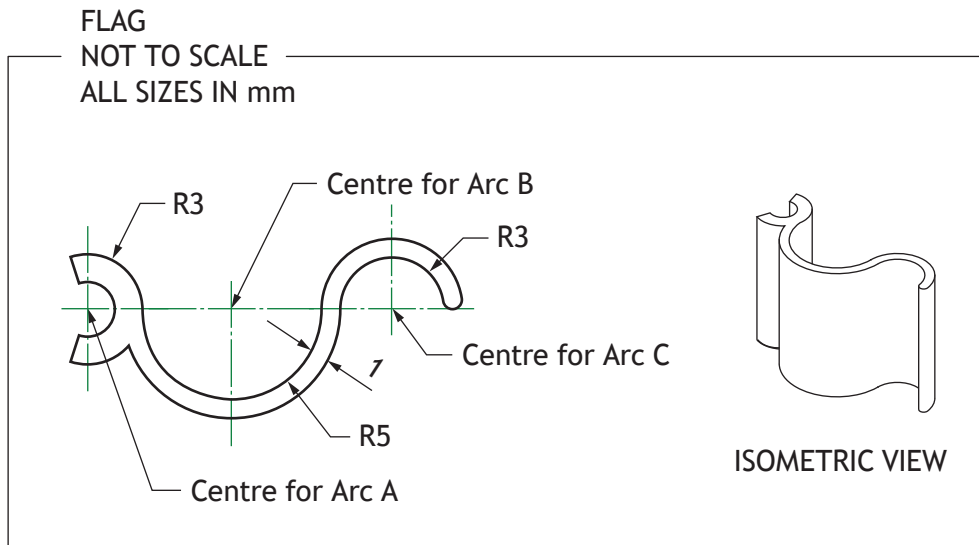

The toy flag component was modelled using tangency.

(b) (i) Explain the term tangency.

You may use sketches to illustrate your answer.

1

(ii) Calculate the following distances.

2

The distance from the centre of arc A to the centre of arc B.

---

The distance from the centre of arc A to the centre of arc C.

---



2. (continued)

MARKS DO NOT WRITE IN THIS MARGIN

A drawing of the toy slide component is shown below.

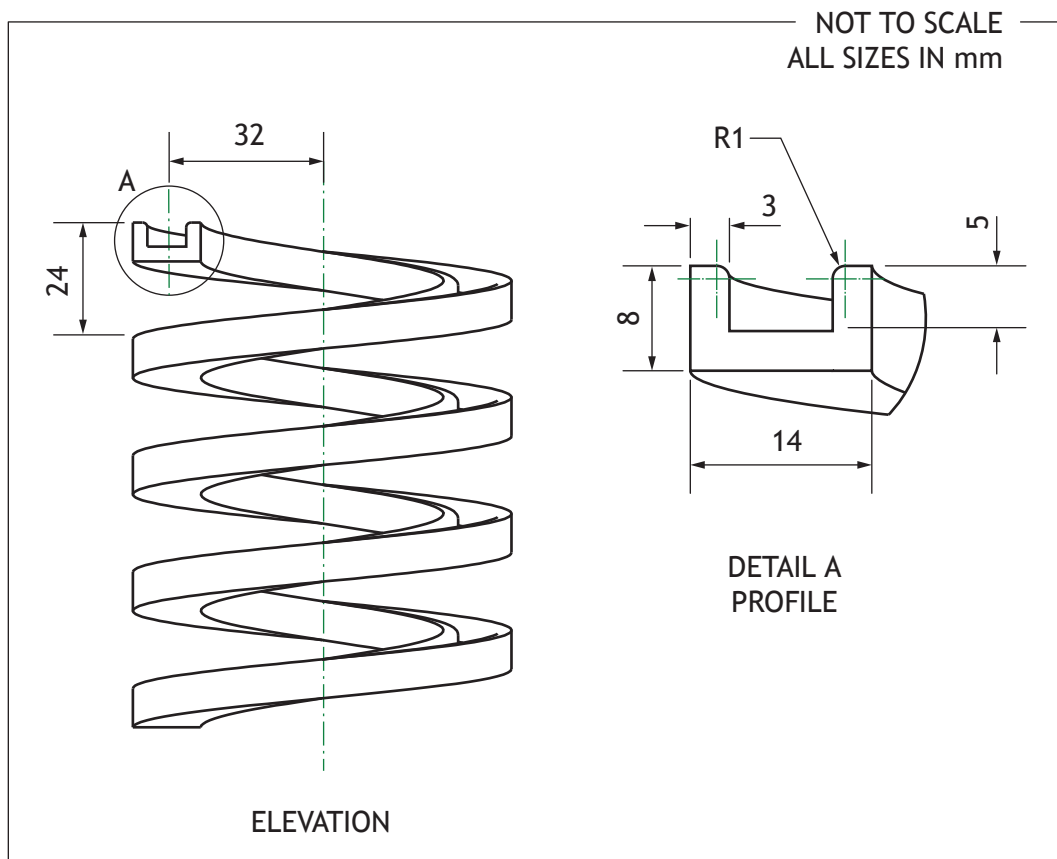

- (c) Describe the single 3D CAD modelling technique used to create the slide component.

You must refer to the dimensions shown in the orthographic drawing shown above.

You may use sketches to support your answer.

4

Blank area for the student's answer.



3. A designer created a rendered 3D CAD illustration and electronic sketches of a concept delivery vehicle shown below.

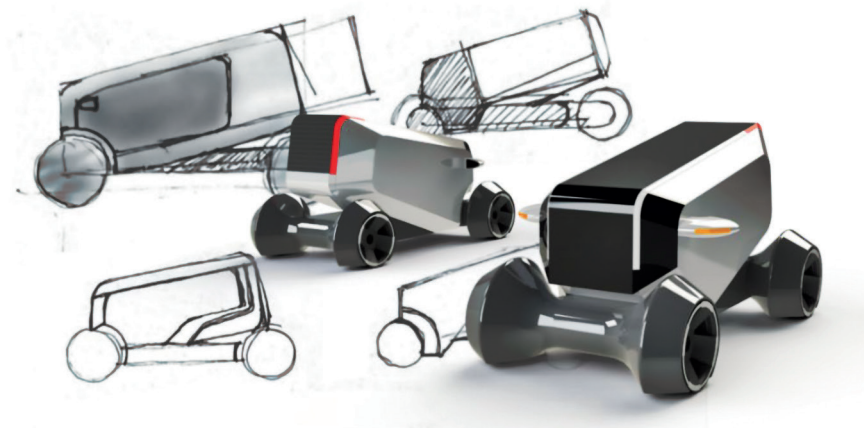

(a) Describe **two** advantages to the designer of using digital sketching instead of manual sketching.

2

---



---



---



---

(b) Describe **three** benefits of using rendered 3D CAD illustrations to show design concepts to a client.

3

---



---



---



---



---



---



3. (continued)

The designer also produced a 3D CAD illustration of the concept delivery vehicle using a sited environment.

- (c) Describe, giving **two** reasons, the purpose of a sited environment. 2

---

---

---

---

The illustrations are saved in a raster file format.

- (d) Explain, giving **two** reasons, why a raster file format is used. 2

---

---

---

---

The designer that carried out the work uses cloud computing-based CAD software.

- (e) Explain, giving **two** reasons, the benefits of using cloud computing. 2

---

---

---

---

[Turn over



3. (continued)

Production drawings of a component from the concept delivery vehicle are shown below.

DO NOT  
WRITE IN  
THIS  
MARGIN

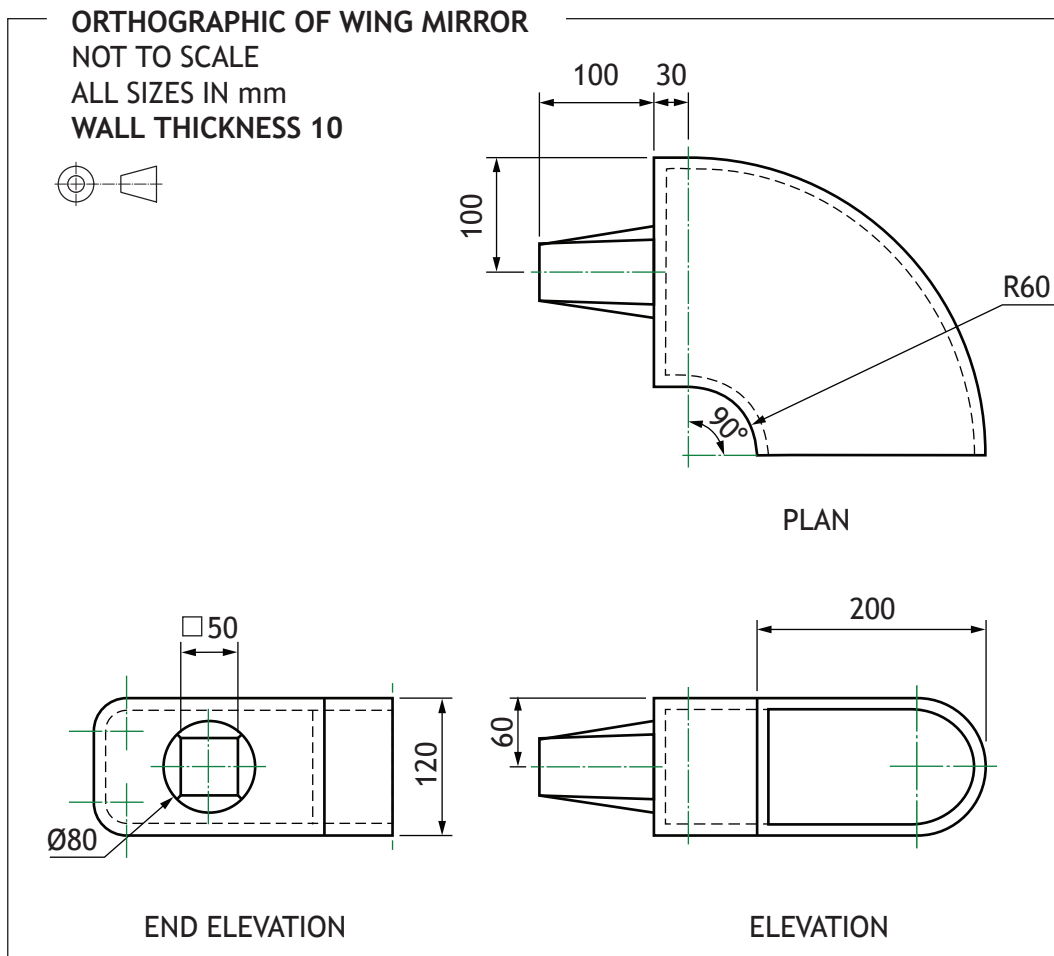
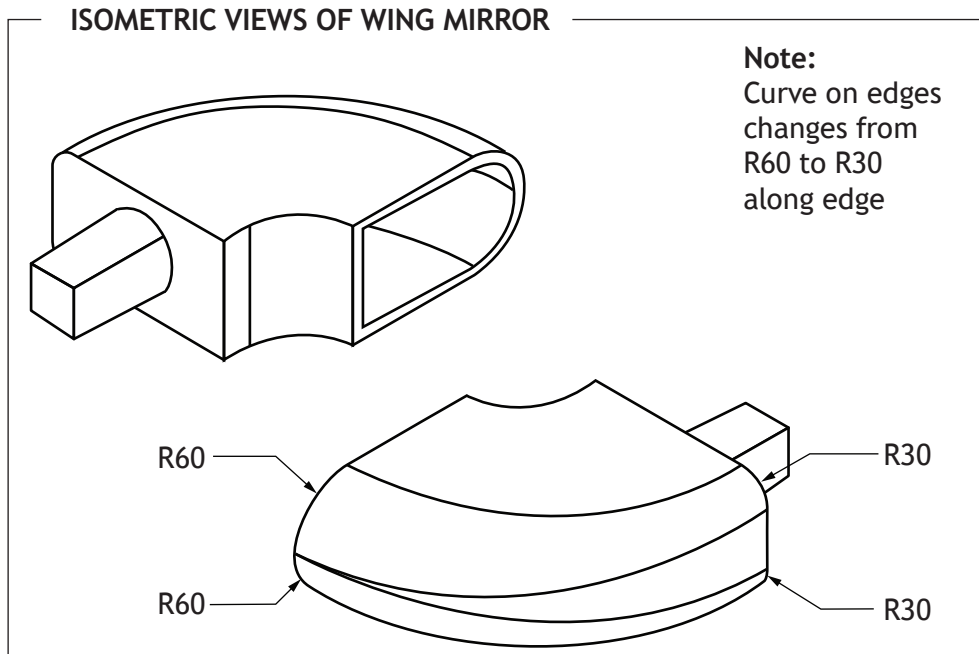

3. (continued)

- (f) Describe the 3D CAD modelling techniques used to create the wing mirror component.

You must refer to the dimensions shown in the drawings on the opposite page to answer this question.

You may use sketches to support your answer.

6



3. (continued)

The 3D CAD model of the wing mirror will be used to create production graphics.

- (g) Describe, giving **two** examples, the benefits of using 3D CAD models in manufacturing.

2

---

---

---

---

---

---

---



4. A range of technical graphics have been produced to support the manufacture of a mounting bracket.

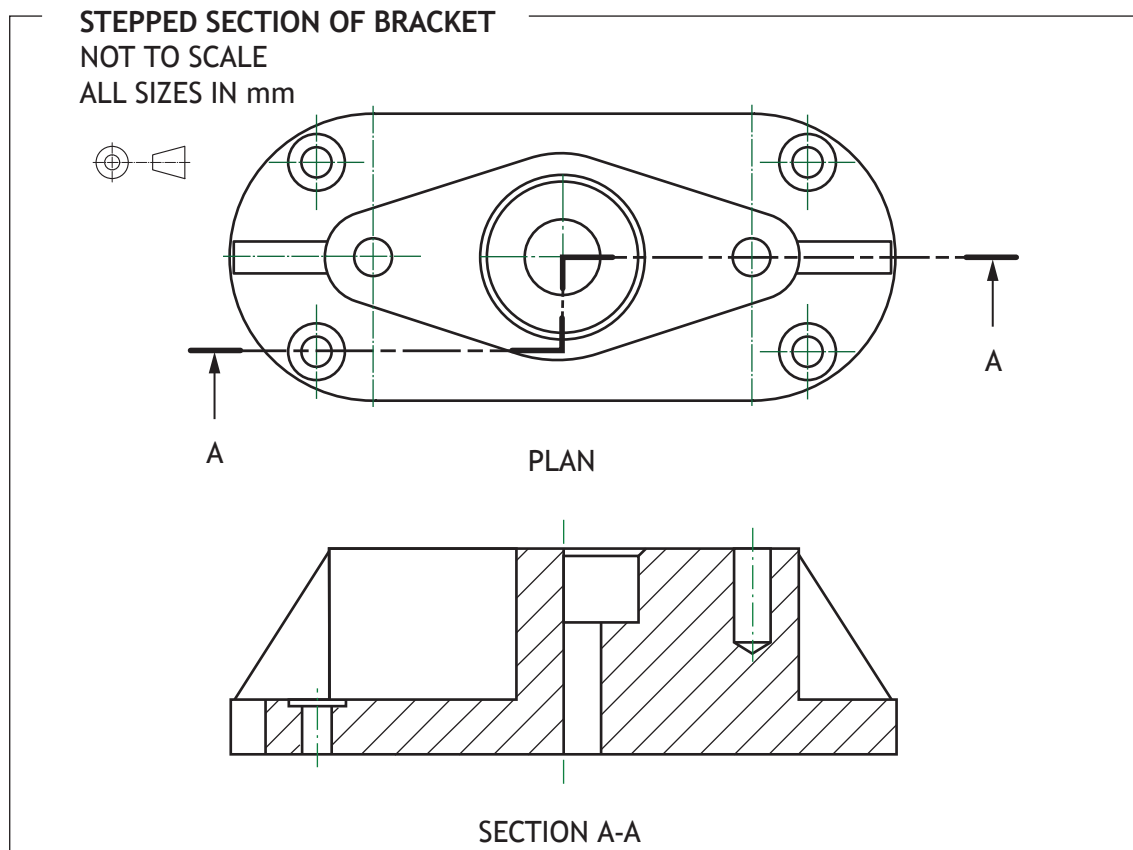
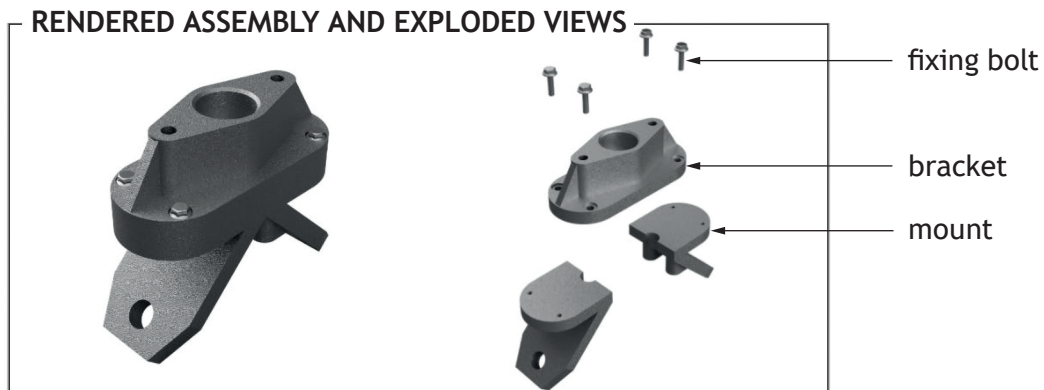

- (a) Explain why a stepped section was used in the drawing above.

1

---



---



---



4. (continued)

The orthographic drawing of the mount is shown below.

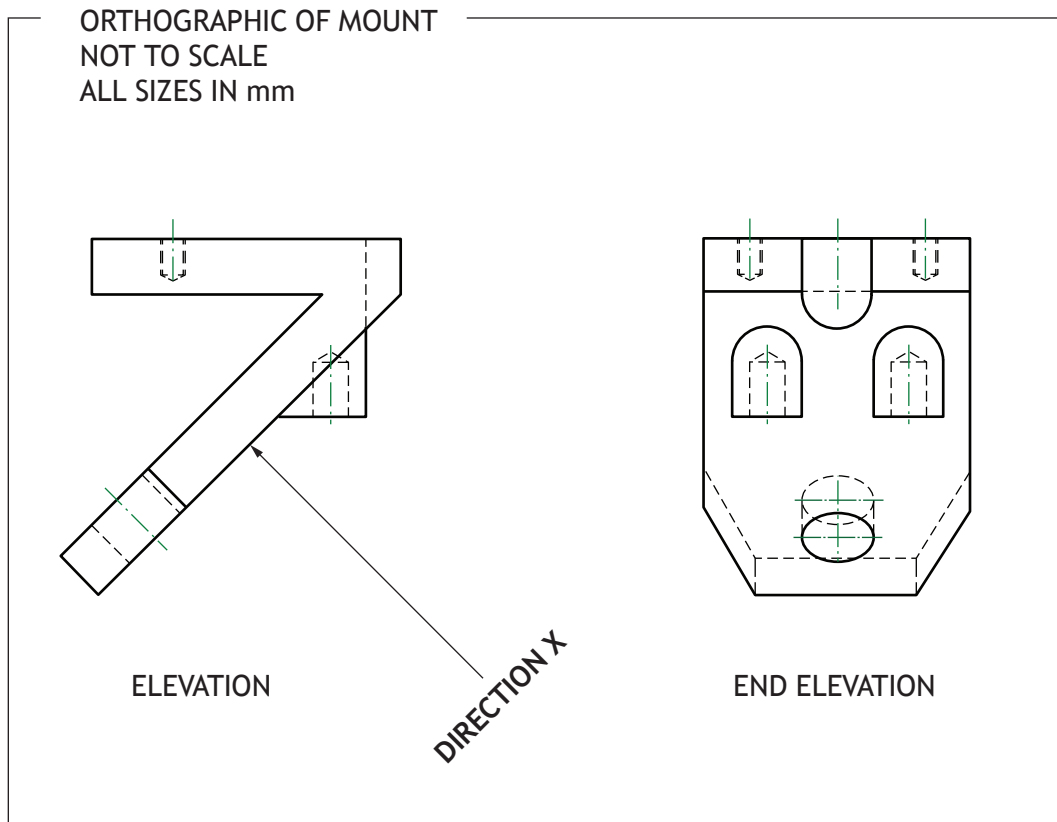

4. (continued)

(b) Identify the correct auxiliary view of the mount in **direction X**, shown in the drawing opposite, by ticking (✓) a box below.

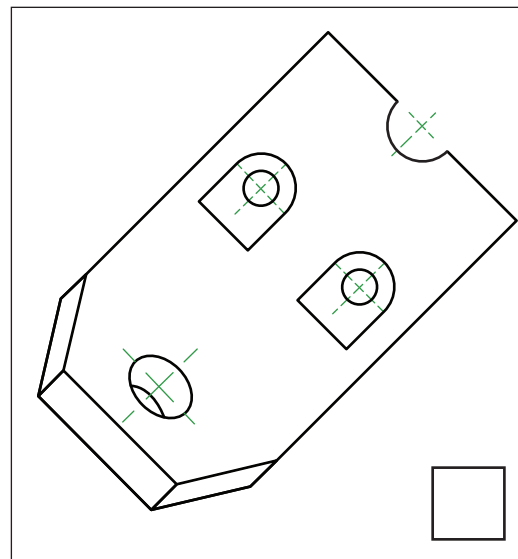
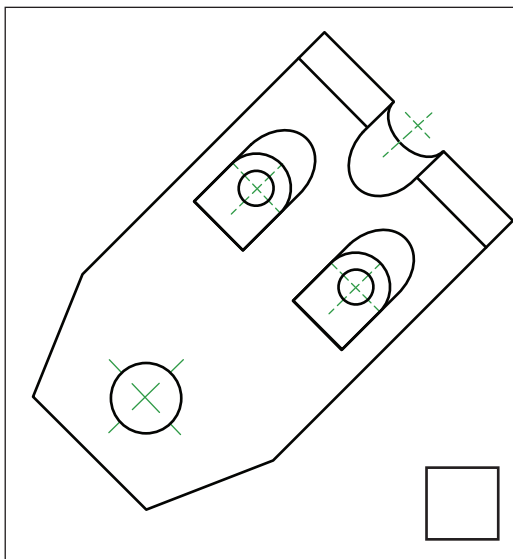
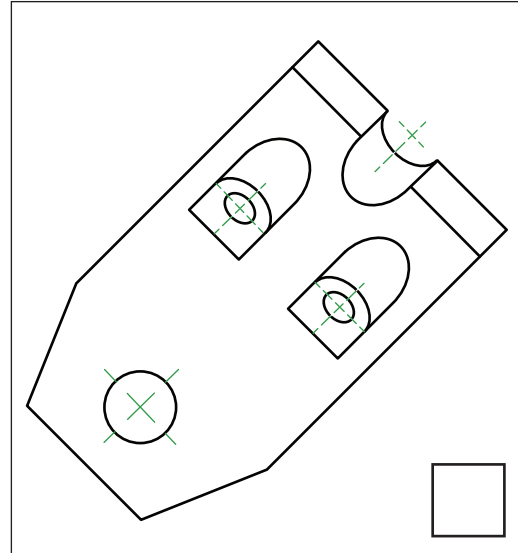
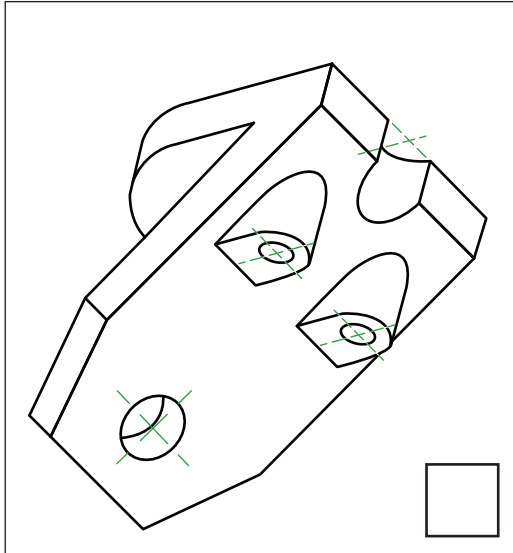

[Turn over



4. (continued)

For question 4(c) you must refer to the supplementary sheets for use with question 4(c).

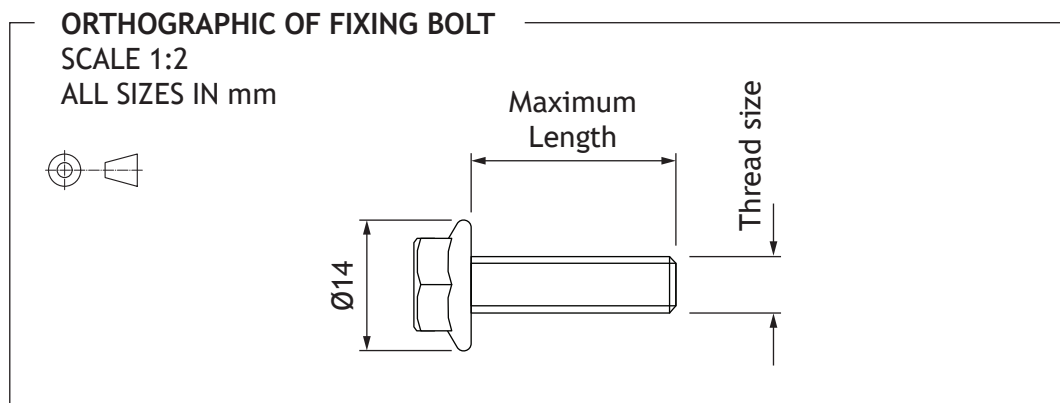

(c) (i) Calculate the maximum length of the threaded section of the fixing bolt. 1

\_\_\_\_\_

(ii) State the thread size of the fixing bolt. 1

\_\_\_\_\_



5. A graphic design company have been asked to create a range of electronic and printed promotional graphics for a travel agent.  
Layouts for a travel app are shown below.

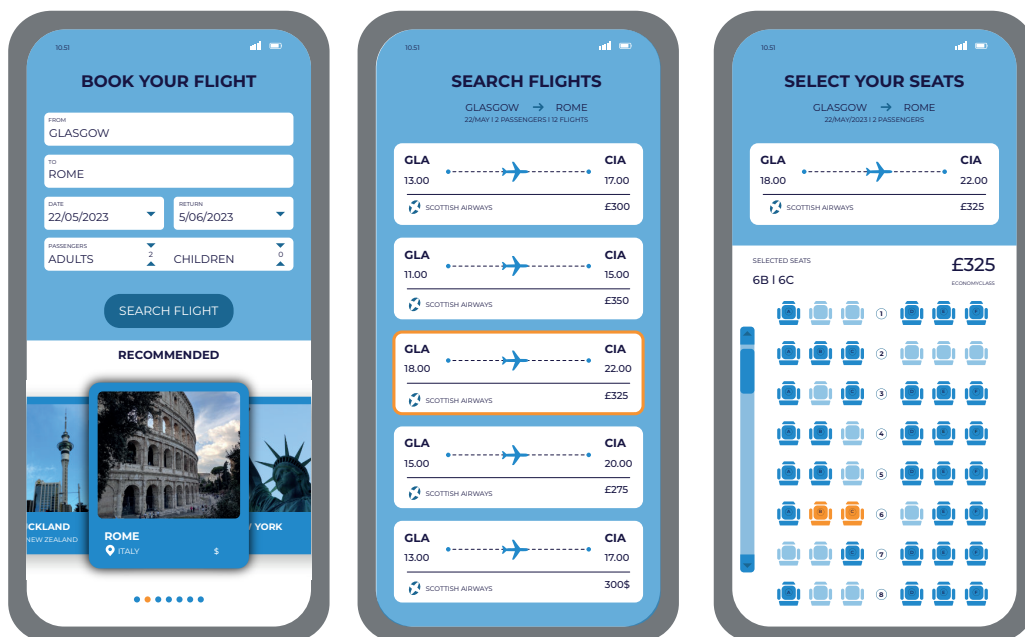

- (a) (i) Explain, giving two reasons, why a limited colour palette and simple graphics have been used for the travel app layouts.

2

---



---



---



---

- (ii) Describe, giving two examples, how the graphic designer has created emphasis in the travel app layouts.

2

---



---



---



---



5. (continued)

MARKS DO NOT WRITE IN THIS MARGIN

In questions 5 (b) to (d) you must refer to the layouts on the supplementary sheets for use with questions 5 (b) to (d).

A series of double page spreads used to advertise holidays are shown on the supplementary sheets for use with questions 5 (b) to (d).



- (b) (i) Describe, giving **two** examples, how the graphic designer has created depth to enhance the layouts.

2

---

---

---

---

---

- (ii) Explain, giving **two** examples, why the graphic designer's use of proportion has enhanced the layouts.

2

---

---

---

---

---

---

---



5. (b) continued

MARKS  
DO NOT  
WRITE IN  
THIS  
MARGIN

(iii) Describe, giving **two** examples, how the graphic designer has created rhythm to enhance the layouts.

2

---

---

---

---

(iv) Explain, giving **two** examples, why the graphic designer's use of shape has enhanced the layouts.

2

---

---

---

---

(v) Describe, giving **two** examples, how the graphic designer has used mass to enhance the layouts.

2

---

---

---

---

Drop caps have been used throughout the layouts.

(c) Explain, giving **two** reasons, why a drop cap can be used to enhance the readability of a document.

2

---

---

---

---

[Turn over



5. (continued)

A pre-press version of the document was created for quality assurance prior to mass printing.

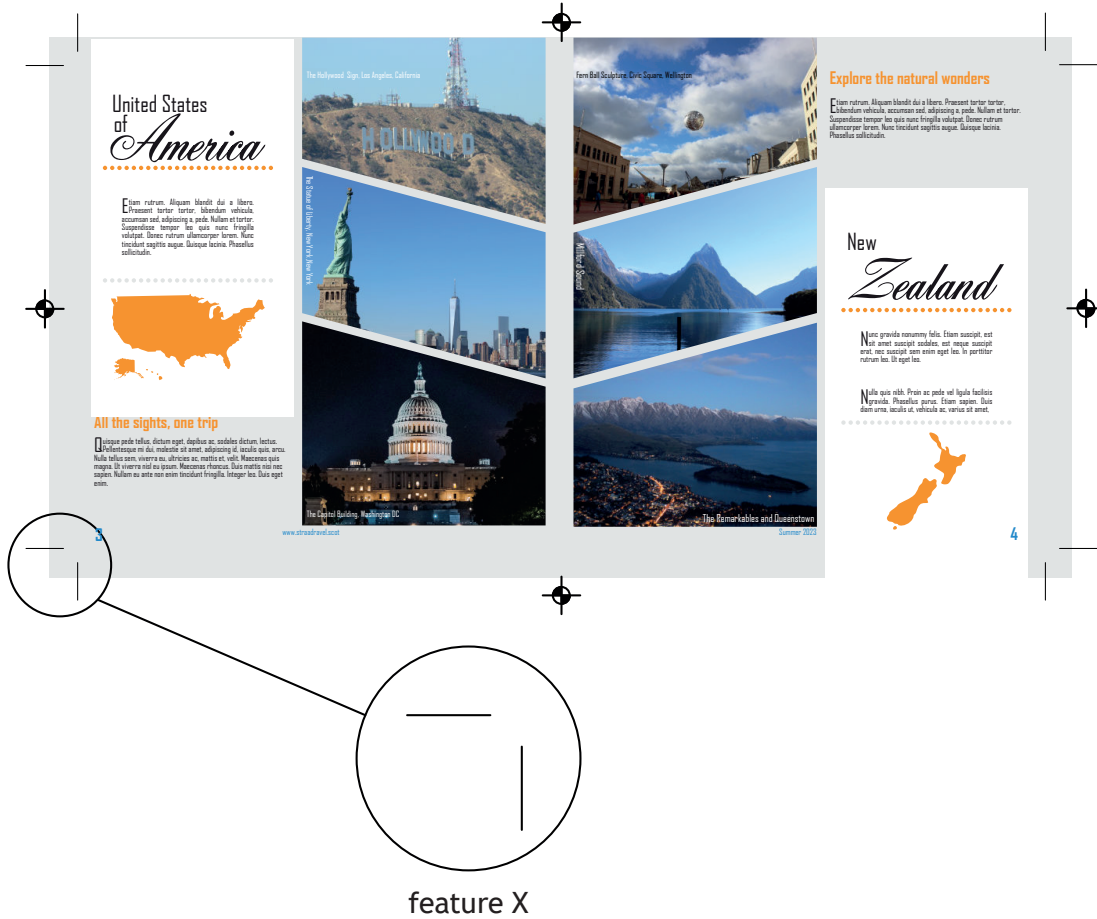

(d) Explain the purpose of feature X.

1

---



---

5. (continued)

The graphic design company employed local photographers for the desktop published items.

- (e) Describe **two** advantages of the company using photographs they own the rights to.

2

---

---

---

---

Vector graphics were used in the layouts.

- (f) Describe **two** advantages of using vector graphics.

2

---

---

---

---

The graphic design company are keen to improve their environmental impact.

- (g) Explain **two edits** that could be made **to the layouts** that would improve their environmental impact.

2

---

---

---

---

---

---

---

[END OF QUESTION PAPER]



MARKS DO NOT  
WRITE IN  
THIS  
MARGIN

ADDITIONAL SPACE FOR ANSWERS



\* X 8 3 5 7 6 0 1 2 2 \*

MARKS DO NOT  
WRITE IN  
THIS  
MARGIN

ADDITIONAL SPACE FOR ANSWERS



\* X 8 3 5 7 6 0 1 2 3 \*

[BLANK PAGE]

DO NOT WRITE ON THIS PAGE

*Acknowledgement of copyright*

Question 5      Image by Monstera is taken from pexels.com,  
                         <https://www.pexels.com/photo/a-world-map-on-the-wall-7412035/>  
                         Image by Jason Gomes is taken from pexels.com, US Capitol Building in Washington  
                         during Night Time · Free Stock Photo (pexels.com)  
                         Image by Liger Pham is taken from pexels.com, Mt. Fuji, Japan · Free Stock Photo  
                         (pexels.com)

