



Higher Graphic Communication Assignment Assessment task

This document provides information for teachers and lecturers about the coursework component of this course in terms of the skills, knowledge and understanding that are assessed. It must be read in conjunction with the course specification.

Valid for session 2023-24 only.

This assessment is given to centres in strictest confidence. You must keep it in a secure place until it is used.

This edition: January 2024 (version 1.1)

© Scottish Qualifications Authority 2024

Contents

Introduction	1
Instructions for teachers and lecturers	2
Instructions for candidates	6

Introduction

This document contains instructions for teachers and lecturers, and instructions for candidates for the Higher Graphic Communication assignment.

This assignment is worth 50 marks. This is 36% of the overall marks for the course assessment.

This is one of two course assessment components. The other component is a question paper.

Instructions for teachers and lecturers

You must conduct the assignment under a high degree of supervision and control. This means:

- ◆ candidates must be within your direct sight
- ◆ candidates must not interact with each other
- ◆ candidates must not have access to email, the internet and mobile phones
- ◆ candidates must complete their work independently – no group work is permitted
- ◆ classroom display materials that might provide assistance must be removed or covered
- ◆ with no interruption for learning and teaching
- ◆ in a classroom environment

Time

Candidates have 8 hours to complete the assignment, starting at an appropriate point in the course after all content has been delivered. Once candidates begin, they must continue in each subsequent class period until the permitted time allocation has been used up.

You have a responsibility to manage candidates' work, distributing it at the beginning and collecting it at the end of each session, and storing it securely in between. This activity does not count towards the total time permitted for candidates to complete the assignment.

Resources

This is a closed-book assessment. Candidates must not have access to learning and teaching materials, the internet, notes, exemplar materials, resources on classroom walls or anything similar.

There may be instances where restriction of internet and/or network use is prohibited (for example, if you have a local authority-managed network with specific limitations or CAD software that is web-based). However, it remains your professional responsibility to make every effort to meet the assessment conditions.

Each assessment task includes instructions and details of any equipment or materials required. Candidates can also use normal classroom equipment, software and hardware (such as CAD and DTP software, and PCs to run the software) to complete the tasks.

Candidates can use a pre-made or existing A3 CAD template.

Reasonable assistance

Candidates must progress through each stage of the assignment without your intervention or guidance, having acquired the skills earlier in the course.

Once candidates complete the assignment, you must not return it to them for further work. You must not provide feedback to candidates or offer an opinion on the perceived quality or completeness of the assignment response, at any stage.

You can provide reasonable assistance to support candidates with the following aspects of their assignment:

- ◆ printing, collating, stapling and labelling their evidence to ensure it is in the format specified by SQA
- ◆ ensuring candidates have all the materials and equipment required to complete the assignment
- ◆ understanding the information outlined in these instructions

Evidence

All candidate evidence (whether created manually or electronically) must be submitted to SQA in a paper-based format.

Each task details what evidence is required and how many pages are expected. This is a guide to ensure that candidates do not produce too much work or spend too long on a single task. Single-sided A3 pages are preferred and are typically the most suitable for the tasks; however, it is acceptable to submit A4 pages if an A3 printer is not available.

Each piece of work must be labelled with the task number, for example, task 3a, and the back of each page must be clearly labelled with candidate details.

Alteration or adaptation

You must not alter, adapt or modify the assignment in any way. This includes moving the content of the assignment into a different format or workbook. All candidates must undertake the assignment exactly as it is provided.

Volume

Candidates should present their work on a maximum of 10 single-sided A3-sized pages.

This figure is given to indicate the volume of evidence required; however, no penalty is applied where candidates exceed this. Full details of evidence requirements are contained within each assessment task.

Specific instructions for teachers and lecturers

You must follow these specific instructions. You must ensure that candidates are aware of the assessment conditions and know what they should do for each task.

Prior to candidates starting the assignment, you must download the following electronic files for their use. You must keep these files secure and candidates must not access them prior to assessment.

- ◆ data sheet 1 – STEP file of a motor
- ◆ data sheet 7 – STEP files of a drone top and a drone bottom
- ◆ data sheet 8 – graphic of a logo (available as both png and svg)
- ◆ data sheet 9 – two graphics of a camera lens
- ◆ data sheet 9 – graphic of circuits
- ◆ data sheet 9 – four graphics of cities
- ◆ data sheet 9 – three graphics of mountain scenes
- ◆ data sheet 9 – three graphics of clouds
- ◆ data sheet 9 – graphic of cogs
- ◆ data sheet 9 – four graphics of textures
- ◆ data sheet 10 – copy text

This assignment has three tasks. Candidates must complete the tasks in order.

Each task has a notional time allocated to it.

Task 1 – 20 marks

(suggested time 3 hours)

- ◆ Tasks 1a to 1c:
Candidates must produce the production drawings electronically. They must generate production drawings from a 3D CAD model they have previously produced.

Task 2 – 24 marks

(suggested time 4 hours)

- ◆ Tasks 2a and 2b:
Candidates must complete the CAD illustration electronically.
- ◆ Task 2c:
Candidates must complete the pull-up banner electronically. They must identify where they have used two principles or elements from the following list: texture, value, balance, emphasis, and proportion.
- ◆ Task 2d:
Candidates can complete the business card manually or electronically.

Task 3 – 6 marks

(suggested time 1 hour)

- ◆ Candidates should complete this task manually. If they use an electronic method, it must not be 3D CAD software. Candidates will gain no marks if they use this software. If candidates use electronic sketching software, they are only permitted to use a straight edge. They must not use any other tools.

Note: candidates must not trace drawings for any part of the assignment. They will gain no marks for traced drawings.

All electronically generated evidence must be printed and compiled for uplift by SQA.

Instructions for candidates

This assessment applies to the assignment for Higher Graphic Communication.

This assignment is worth 50 marks. This is 36% of the overall marks for the course assessment.

It assesses the following skills, knowledge and understanding:

- ◆ creativity when responding to graphic design tasks and situations
- ◆ using graphic communication technologies to meet a purpose
- ◆ producing preliminary, production and promotional graphic items in response to a situation or problem
- ◆ applying illustration and presentation techniques to create graphics with relevant visual impact
- ◆ producing 2D and 3D production drawings, applying appropriate standards, protocols and conventions
- ◆ producing promotional graphic publications to meet an agreed content and style
- ◆ reviewing and evaluating your progress, giving justification for your choice of graphic items and the graphic communication techniques employed

Note: you must not trace drawings for any part of the assignment – you will gain no marks for traced drawings.

In this assessment, you have to produce a range of graphics in response to a brief:

- ◆ in the order presented
- ◆ that assesses aspects of the skills and knowledge listed above
- ◆ in 8 hours, excluding the time you need to set up and clear away any equipment you use, and for any printing you need to do

You must not use any text, images, or other items from any other source unless you create them during this 8-hour assignment.

There are three tasks, with marks allocated as follows:

Task 1 – 20 marks: producing production drawings for a drone prototype
(suggested time 3 hours)

Task 2 – 24 marks: producing preliminary and promotional graphics for a drone prototype
(suggested time 4 hours)

Task 3 – 6 marks: producing preliminary graphics for a controller cradle proposal
(suggested time 1 hour)

Your teacher or lecturer will provide you with:

- ◆ the Graphic Communication brief
- ◆ tasks 1 to 3
- ◆ data sheets 1 to 12
- ◆ STEP files of a motor, drone top, and drone bottom
- ◆ electronic files of the graphics shown in data sheets 8 and 9

Assessment conditions

This is a closed-book assessment. You must undertake the assignment under a high degree of supervision and control. This means:

- ◆ you must be within direct sight of your teacher or lecturer
- ◆ you must not interact with other candidates
- ◆ you must not have access to email, the internet and mobile phones
- ◆ you must complete your work independently – no group work is permitted

You have 8 hours to complete the assignment. Once you begin, you must continue in each subsequent class period until the permitted time allocation has been used up.

Reasonable assistance

You must progress through each stage of the assignment without intervention or guidance from your teacher or lecturer.

Once you have completed the assignment, your teacher or lecturer cannot return it to you for further work. They will not give you feedback on your assignment response at any stage.

They can give you reasonable assistance to support with the following aspects of your assignment:

- ◆ printing, collating, stapling and labelling your evidence to ensure it is in the format specified by SQA
- ◆ ensuring you have all the materials and equipment required to complete the assignment
- ◆ understanding the information outlined in these instructions

Submitting your work

You must label each piece of evidence with the task number (for example task 1a), and the back of each page with your:

- ◆ name
- ◆ date of birth
- ◆ Scottish Candidate Number (SCN)
- ◆ centre name
- ◆ centre number

Graphic Communication brief

An electronics company, CertadronesUK, has designed a new drone prototype.

The company needs a range of graphics for the drone prototype and a pull-up banner. They have asked you to create:

- ◆ production drawings to manufacture the drone prototype sub-assembly components
- ◆ 3D illustrated graphics to showcase the assembled drone prototype
- ◆ a pull-up banner and business card, with relevant desktop published graphics

The company has provided:

- a company logo, fonts, and colours
- copy text
- pre-approved promotional graphics

Note: you cannot alter the company name, logo, or company colours.

- ◆ preliminary sketches of a controller cradle

Use the data sheets provided to guide you through the assignment.

Task 1: drone prototype sub-assembly

A CAD technician has prepared a series of draft CAD drawings for manufacturing the drone prototype sub-assembly.

Using the draft CAD drawings and information on data sheets 1, 2, 3, 4, 5, and 6, model the drone prototype sub-assembly components using 3D CAD software.

From your models, produce production drawings based on the drone prototype sub-assembly shown.

You can use top-down modelling or bottom-up modelling in your work.

For all drawings in task 1, you must:

- ◆ use the same orientation as the given orthographic views on each individual data sheet
- ◆ produce all views as line drawings, do not render the views
- ◆ correctly label all views with an appropriate font size
- ◆ include the following British Standard conventions:
 - linear (parallel and chain as appropriate), radial, diameter, and angular dimensions
 - the third-angle projection symbol, where appropriate
 - a title block including relevant information
- ◆ include hidden detail, centre lines, appropriate dimensions for manufacture, and annotations, unless stated

- 1a (i) Produce an elevation, a plan, and an auxiliary plan of the propeller (part 1). You must produce all views at a scale of 2:1.

Your drawing must include:

- ◆ the auxiliary plan, including the true shape of surface X
- ◆ a minimum of one angular dimension

(4 marks)

- (ii) Produce an elevation, a plan, and an end elevation of the motor housing (part 2). You must produce all views at a scale of 3:1.

Your drawing must include:

- ◆ chain and parallel dimensions

(3 marks)

- (iii) Produce an elevation, a plan, and a sectional end elevation of the connecting arm (part 4). You must produce all views at a scale of 2:1.

Your drawing must include, as highlighted on data sheet 6:

- ◆ the sectional end elevation through cutting plane X
- ◆ a dimensional tolerance of ± 0.25 applied to the annotated dimension

(3 marks)

- 1b Produce an elevation, a plan, and stepped sectional end elevation of the drone prototype sub-assembly components as shown on data sheet 2.

You must produce this view at a scale of 1:1.

The drone prototype sub-assembly must be assembled as shown on data sheet 2.

Your drawing must include:

- ◆ the stepped sectional end elevation through cutting plane Y, as highlighted on data sheet 2
- ◆ the motor STEP file on data sheet 1, which must be fully inserted into the diameter 16 hole in the motor housing (part 2), and assembled into the corresponding hole in the propeller (part 1)
- ◆ the propeller, assembled at the angle indicated on data sheet 2
- ◆ an enlarged partial view, at a scale of 3:1, taken from the stepped sectional view to show how all components fit together

Do not include dimensions or show hidden detail.

(6 marks)

- 1c Produce an exploded isometric view of the assembled drone prototype sub-assembly from task 1b in the orientation shown on data sheet 1.

- ◆ Do not show hidden detail.
- ◆ You must produce the view as a line drawing.
- ◆ You must not render the exploded isometric view.

(2 marks)

- 1d Include the following British Standard conventions in your drawings:

- ◆ a title block, including relevant information and all views correctly labelled
- ◆ appropriate dimensions for manufacture across all component drawings
- ◆ line types, including visible outlines, hidden outlines, centre lines, hatching and dimensions

(2 marks)

Note: you must create all the production drawings for task 1 electronically and print out all your work.

You should complete task 1 on four single-sided A3-sized pages.

You should spend approximately 3 hours on task 1.

Your completed assignment (tasks 1 to 3) should be on no more than 10 single-sided A3-sized pages.

Task 2: promotional graphics

The company needs 3D illustrated graphics and a pull-up banner for the drone product launch.

Data sheets 7, 8, 9, and 10 contain information on the proposed 3D illustrated graphics and pull-up banner.

The company has asked you to create:

- ◆ 3D computer-rendered graphics of the assembled drone prototype
- ◆ graphics for a pull-up banner

The company has provided:

- ◆ a company logo, fonts, and colours
- ◆ copy text
- ◆ pre-approved promotional graphics

Note: you cannot alter the company name, logo, or company colours.

2a Create a fully assembled model of the drone prototype.

Your assembled model must include the:

- ◆ sub-assembly of your drone components from task 1b four times, as highlighted on data sheet 7 in viewpoint 1
- ◆ STEP files provided of the drone top and drone bottom (You must ensure the STEP files are at a suitable scale and make sure they are assembled as shown on data sheet 7.)

(2 marks)

2b Produce pictorial illustrations of the fully assembled drone prototype.

You must produce pictorial illustrations from **two** different viewpoints, like viewpoint 1 and viewpoint 2 on data sheet 7.

Your illustrations must be free from pixilation and grain. Your shadows and lighting must be high quality.

Your illustrations must include:

- ◆ material specifications:
 - a textured metal on a minimum of one component or STEP file, suitably scaled
 - a minimum of one component or STEP file that features two separate colours or textures on a single component

- suitable colours or materials applied to the remaining components and STEP files
- ◆ the logo graphic decal applied to the top curved surface of the drone top STEP file
 - data sheet 7 illustrates this
- ◆ appropriate and effective highlights and shadows applied to the fully assembled drone prototype model

You must print each viewpoint on an individual landscape A3-sized sheet, scaled to fit as large as possible.

(8 marks)

2c Produce a desktop published pull-up banner using data sheets 8, 9, and 10.

Your layout must demonstrate your skill in using desktop publishing terms and techniques, design elements and principles and have a strong visual impact.

There is no template for task 2c. You must use the sizes on data sheet 8 when creating your layout.

Your layout must include effective use of:

- ◆ the colour and layout details on data sheet 8
- ◆ the design principle of rhythm
- ◆ the desktop publishing technique of transparency
- ◆ two design elements or principles from the following list:
 - texture
 - value
 - balance
 - emphasis
 - proportion

(You must include appropriate annotations to identify where you have used your chosen design elements or principles.)

- ◆ the company logo from data sheet 8
- ◆ a minimum of two CMYK colours from data sheet 8
- ◆ a minimum of one font from data sheet 8
- ◆ a minimum of two graphics from data sheet 9
- ◆ full cropping applied to one of your chosen images from data sheet 9
- ◆ use of the copy text from data sheet 10
- ◆ viewpoint 1 pictorial illustration from task 2b

You can also add other graphic items, provided you create them within the 8 hours of this assignment.

You can use the graphics on data sheet 9 as they are, or you can edit them to suit your design.

(11 marks)

2d Produce a **preliminary** layout for a business card to compliment the pull-up banner produced in task 2c, using data sheets 8, 9 and 10.

Your layout must demonstrate your skill in using desktop publishing terms and techniques, design elements and principles and have a strong visual impact.

Your business card must:

- ◆ follow the theme and styling you created in task 2c
- ◆ include the company logo and copy text from data sheet 10
- ◆ include the design principle grid structure, this must be clearly identified
- ◆ include the dtp technique reverse
- ◆ be 85mm by 55mm, landscape

You can also add other graphic items, provided you create them within the 8 hours of this assignment.

You can use the graphics on data sheet 9 as they are, or you can edit them to suit your design.

(3 marks)

Note: you must produce tasks 2a, 2b and 2c electronically and print out all your work.

You can complete task 2d manually or electronically. If you complete it electronically, you must print out all your work.

You should complete task 2 on four single-sided A3-sized pages.

You should spend approximately 4 hours on task 2.

Your completed assignment (tasks 1 to 3) should be on no more than 10 single-sided A3-sized pages.

Task 3: controller cradle

A CAD technician has prepared graphics for a proposed controller cradle.

Using the graphics on data sheet 11, produce preliminary sketches to showcase this proposal.

You will not gain any marks if you measure, trace, or use any drawing instruments (other than a straight edge). If you use an electronic method, it must not be 3D CAD software. You will gain no marks if you use this software.

- 3 Produce a preliminary **orthographic** sketch that includes an elevation, a plan and a sectional end elevation of the controller cradle in the orientation shown on data sheet 11. The cutting plane for the sectional end elevation is highlighted on data sheet 11.

Your sketch must accurately represent the controller cradle on data sheet 11 and:

- ◆ take notice of the direction of viewing for the elevation and sectional end elevation.
- ◆ include hidden detail in the elevation and plan.
- ◆ be produced in third-angle projection.
- ◆ the orthographic views must fill most of the A3 page to maximise clarity.
- ◆ **not** include colour, highlights, or shadows.
- ◆ **not** include centre lines.

(6 marks)

Note: you can complete task 3 manually or electronically. If you complete it electronically, you must print out all your work.

You should complete task 3 on one single-sided A3-sized pages.

You should spend approximately 1 hour on task 3.

Your completed assignment (tasks 1 to 3) should be on no more than 10 single-sided A3-sized pages.

Data sheet 1 – drone prototype sub-assembly



PROPELLER

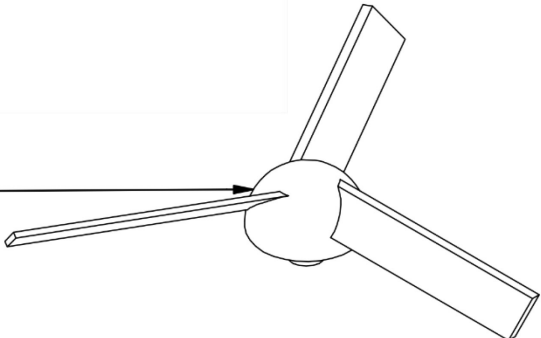

MOTOR
provided as STEP file

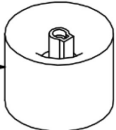

MOTOR HOUSING

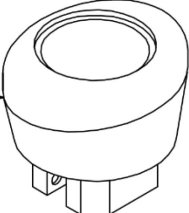

CONNECTING ARM

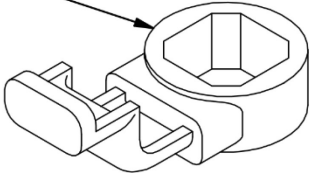

SHOCK LEG

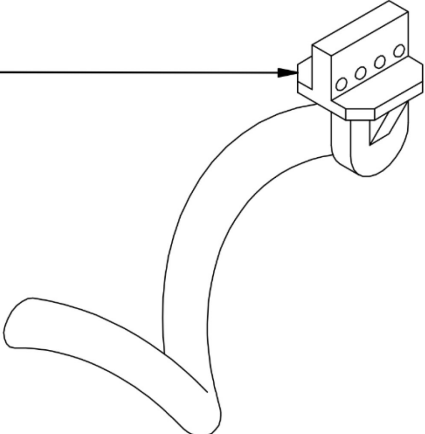

Data sheet 2 – drone prototype sub-assembly

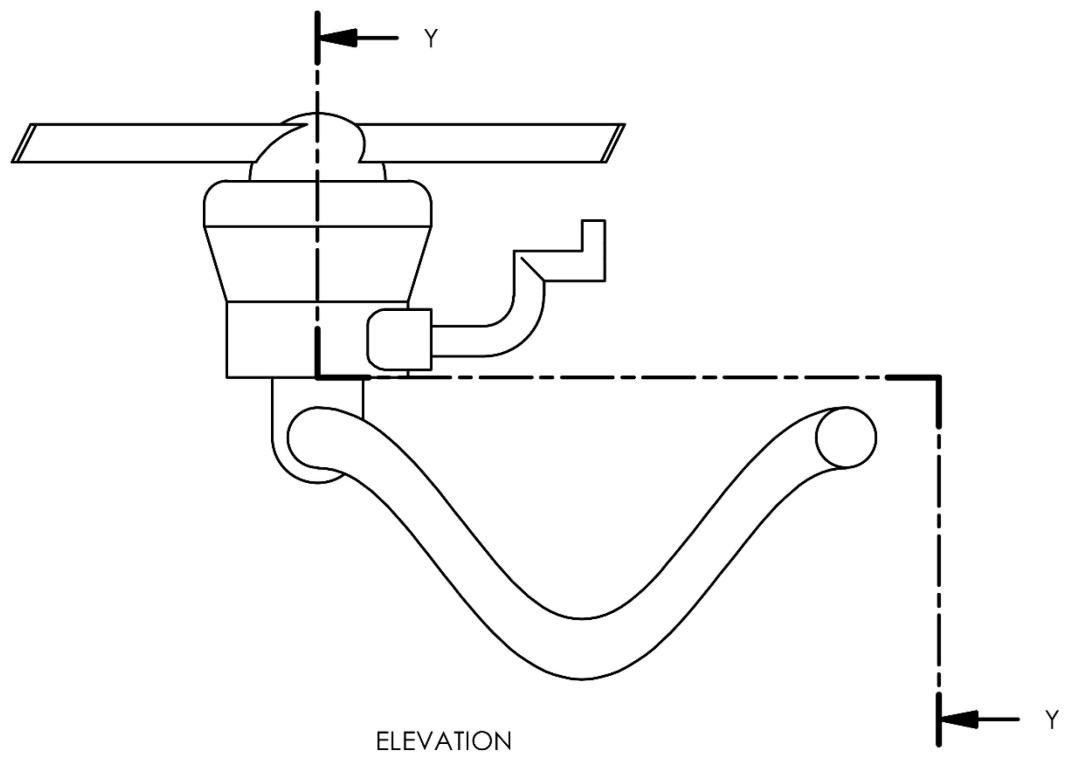
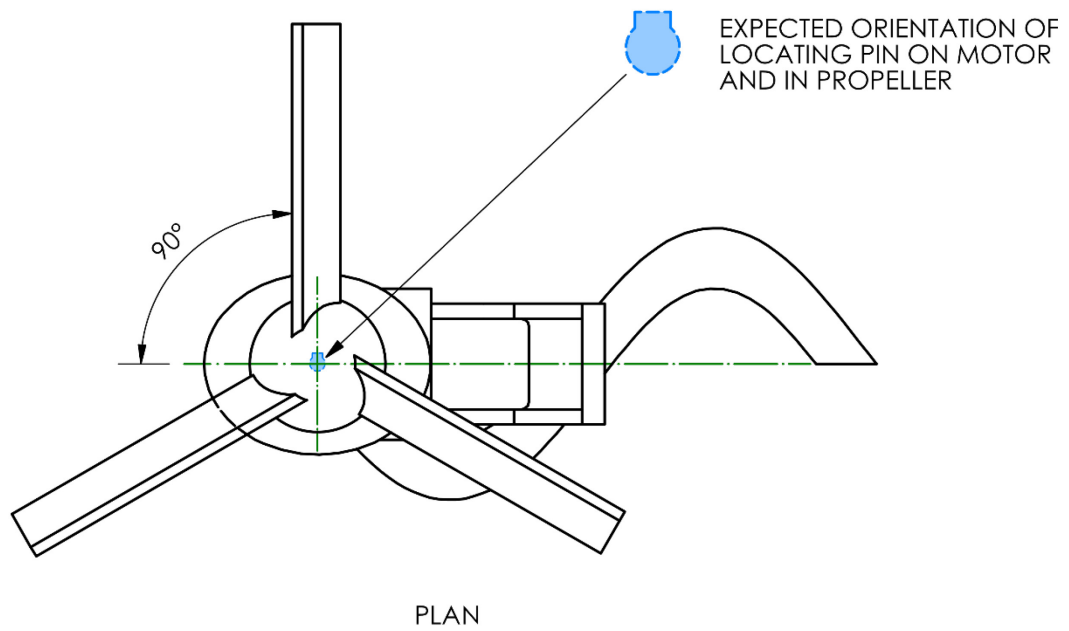

SOME CENTRE LINES AND
HIDDEN DETAIL OMITTED
FOR CLARITY
NOT TO SCALE

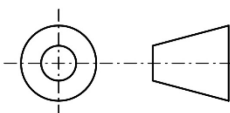

Data sheet 3 – propeller (part 1)

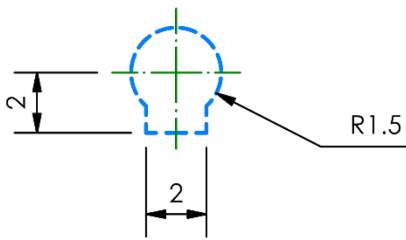

ENLARGED PARTIAL VIEW B
OF PROFILE
SOME DETAIL REMOVED
FOR CLARITY

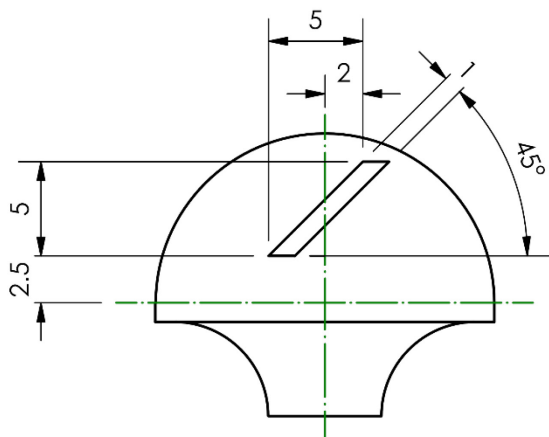

ENLARGED PARTIAL VIEW A
HIDDEN DETAIL AND TWO BLADES
REMOVED FOR CLARITY

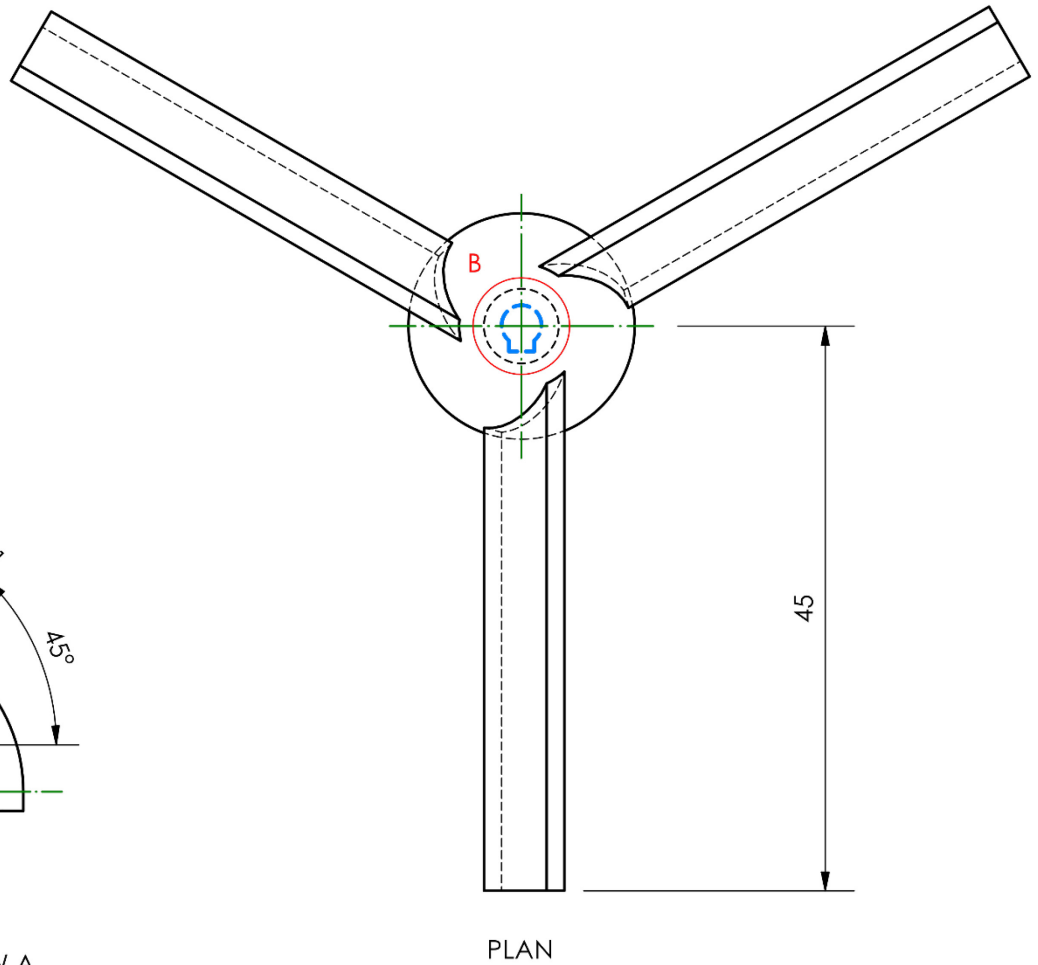

PLAN

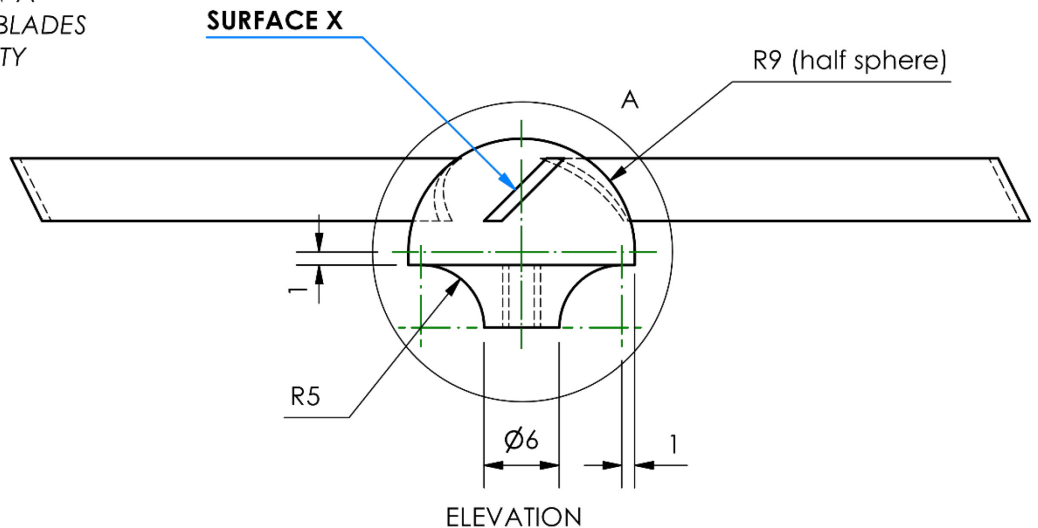

ELEVATION

**3 BLADES EQUALLY
SPACED AROUND 360°**

NOT TO SCALE

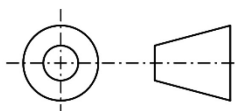

Data sheet 4 – motor housing (part 2)

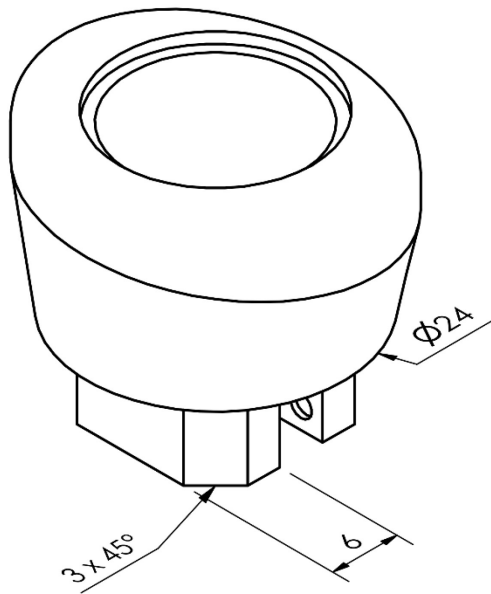

PICTORIAL VIEW

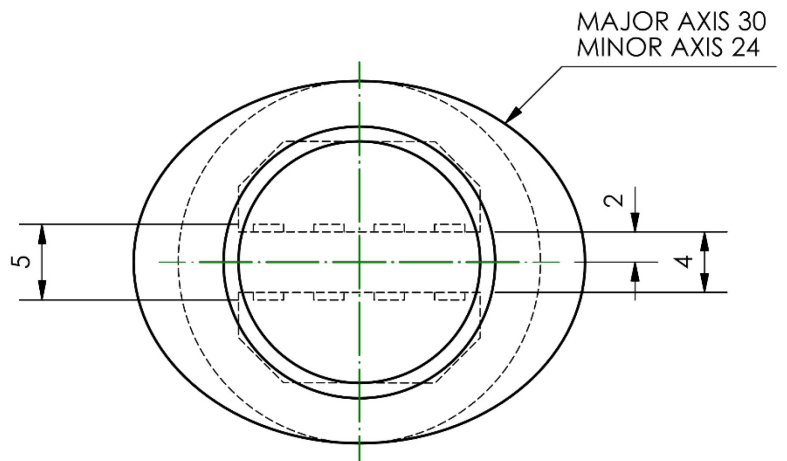

PLAN

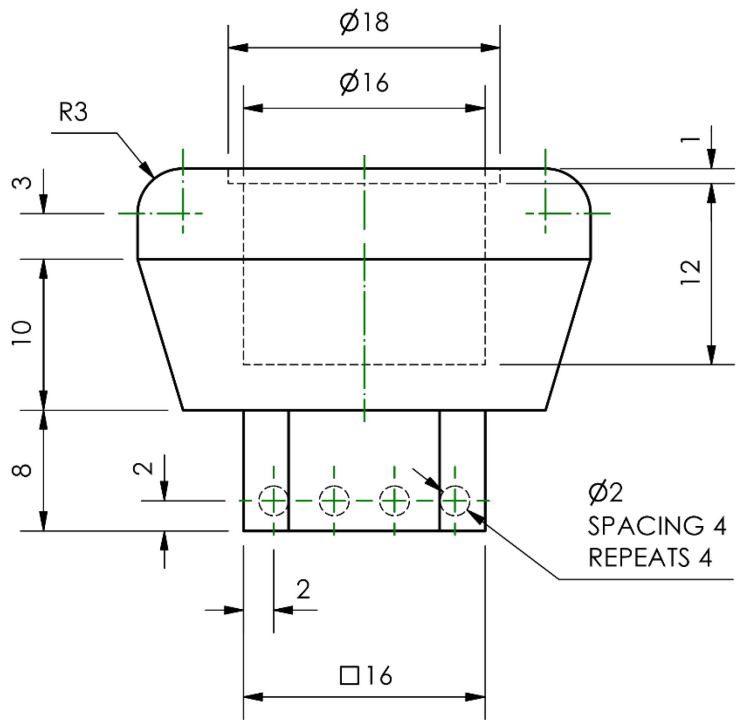

ELEVATION

BLIND HOLES 0.5 DEEP
 SOME CENTRE LINES AND
 HIDDEN DETAIL OMITTED
 FOR CLARITY
 NOT TO SCALE

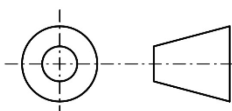

Data sheet 5 – shock leg (part 3)

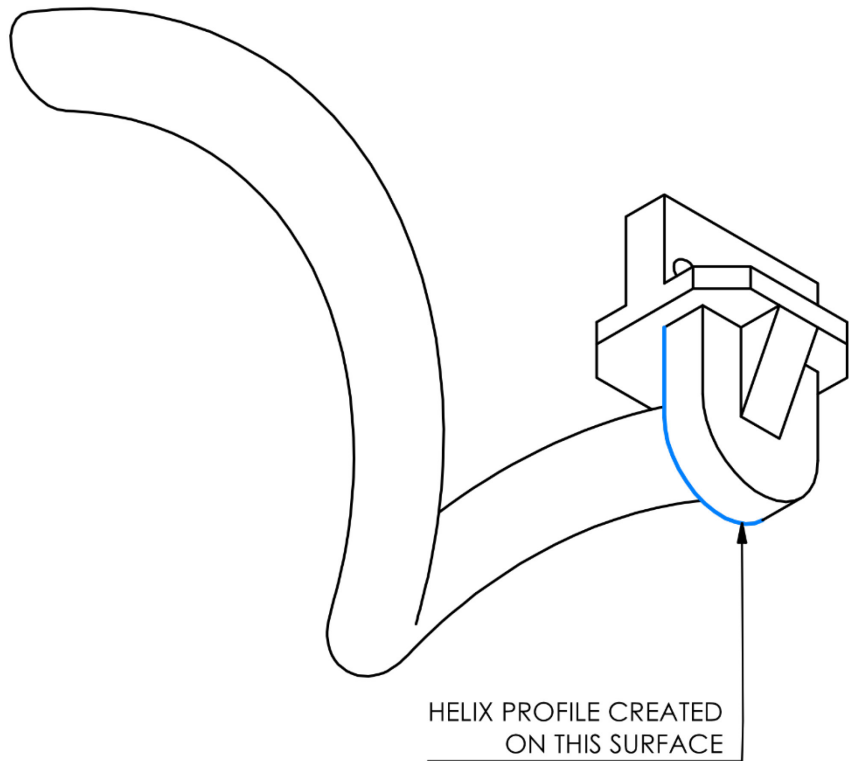
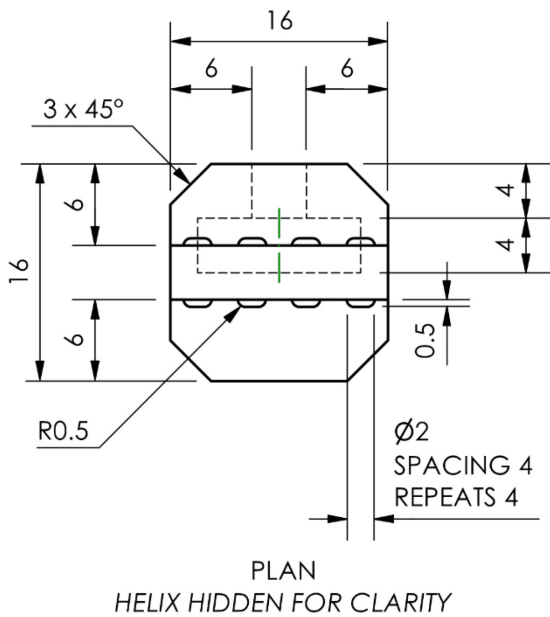

PICTORIAL VIEW

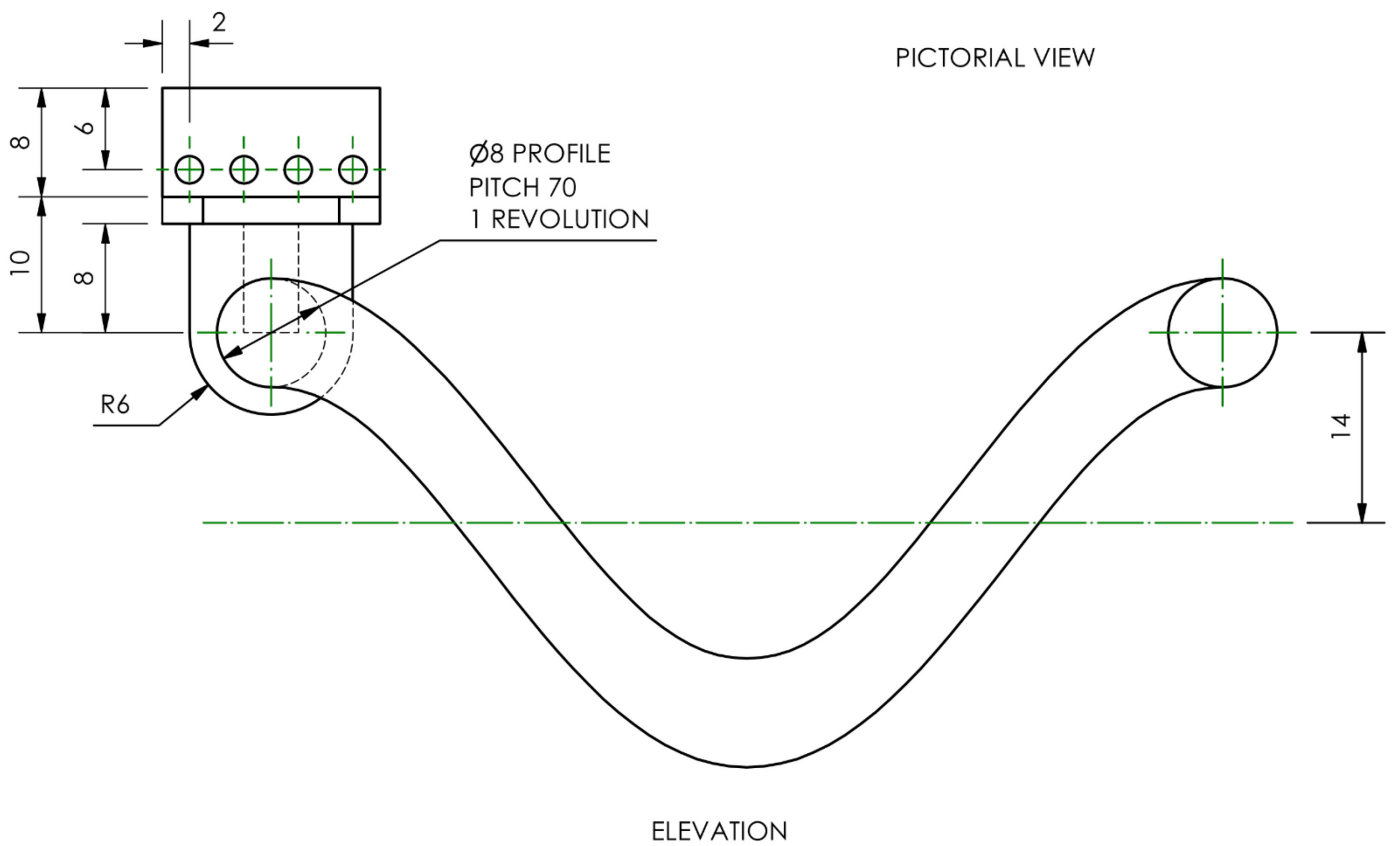

NOT TO SCALE

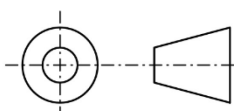

Data sheet 6 – connecting arm (part 4)

TOLERANCE OF ± 0.25 APPLIED TO THIS DIMENSION

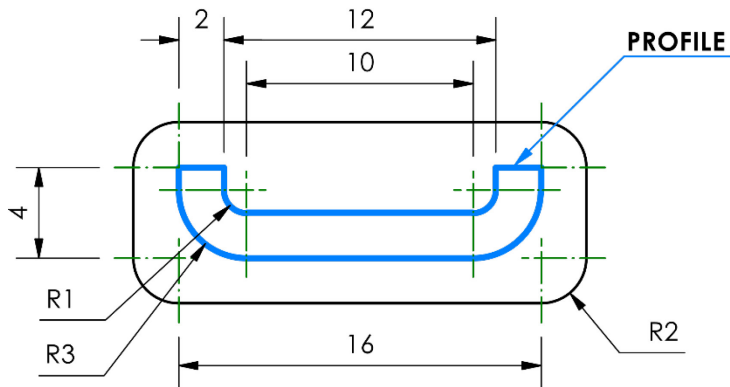
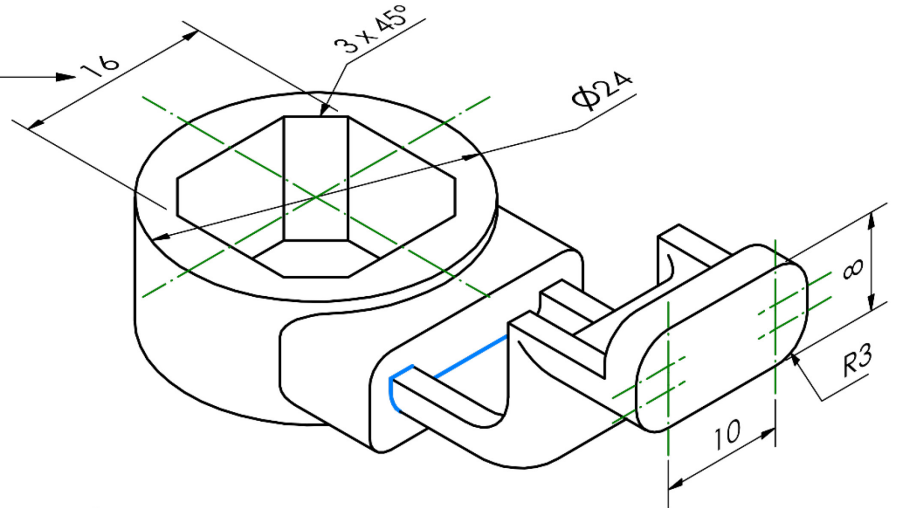

ENLARGED VIEW OF PROFILE

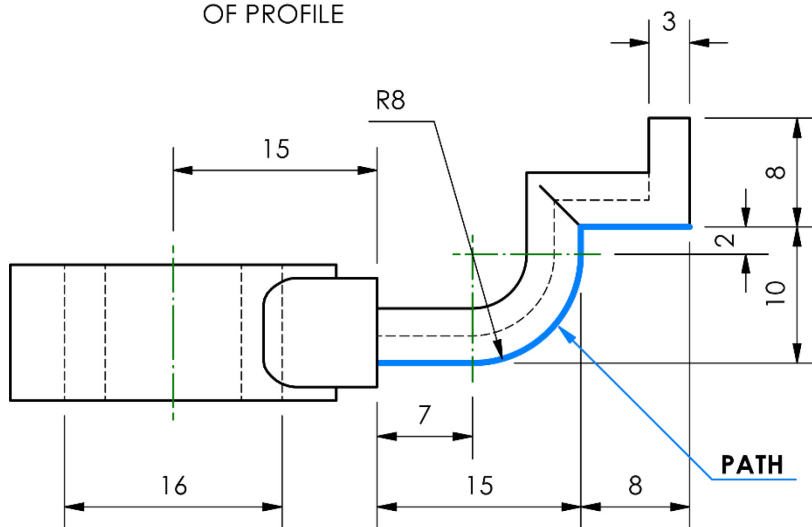

END ELEVATION

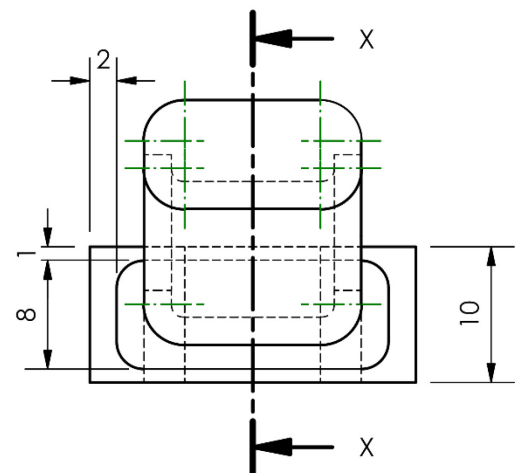

ELEVATION

Profile and path of part of the arm are highlighted in blue
NOT TO SCALE

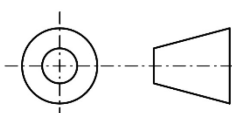

Data sheet 7 – STEP files and viewpoints

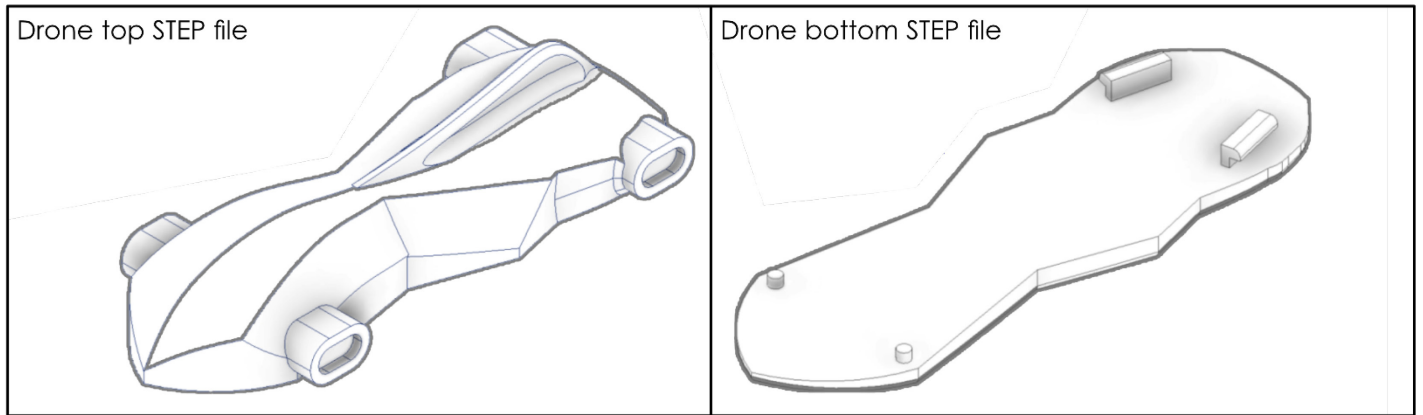

Viewpoint 1: Example of viewpoint showing complete drone

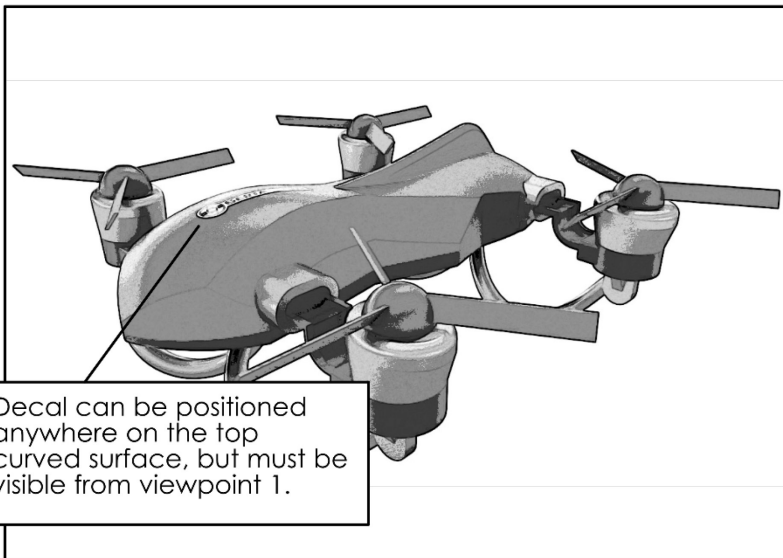

Decal can be positioned anywhere on the top curved surface, but must be visible from viewpoint 1.

Example viewpoints are shown on representations of two sheets of A3 paper. Renders must be as close to the size of paper they are printed on as possible. If an A3 printer is not available, A4 paper is acceptable, the renders must take up the full A4 sheet.

If using company colours in render of drone, the RGB values are:

Colour 1	Colour 2	Colour 3	Colour 4
R: 30	R: 148	R: 169	R: 240
G: 41	G: 37	G: 31	G: 91
B: 80	B: 128	B: 36	B: 125

Viewpoint 2: Example of viewpoint showing zoomed render of textured metal

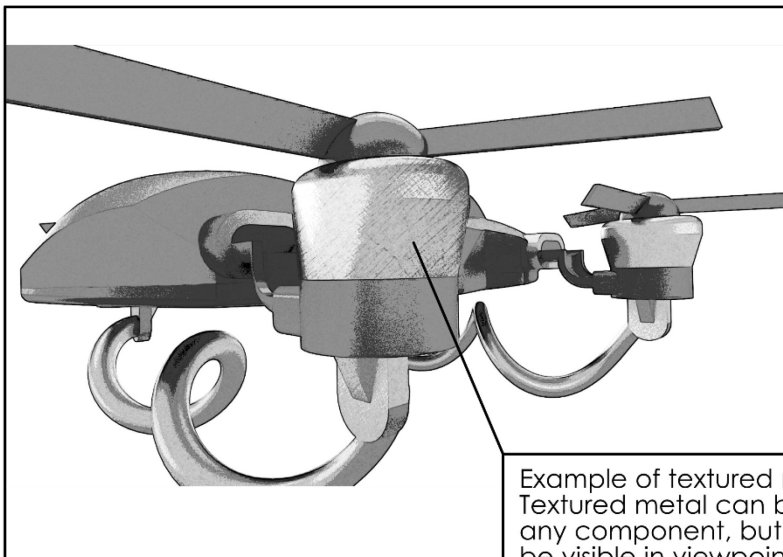

Example of textured metal. Textured metal can be on any component, but must be visible in viewpoint 2.

Data sheet 8 – pop-up banner

Approved CMYK colours

Colour 1	Colour 2	Colour 3	Colour 4
C: 100	C: 48	C: 24	C: 0
M: 93	M: 100	M: 100	M: 80
Y: 45	Y: 12	Y: 100	Y: 30
K: 31	K: 1	K: 15	K: 0

Fonts

BANK GOTHIC LT BT
 Century Gothic
 Calibri
 Agency FB

Logo



Pull-up banner



Document setup

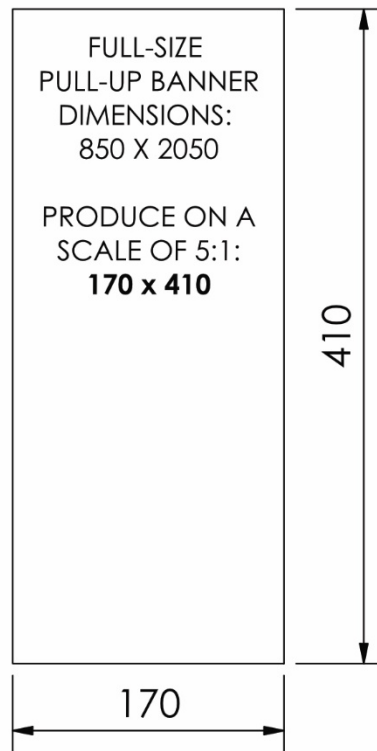

ALL SIZES IN MM

Grids/guides setup

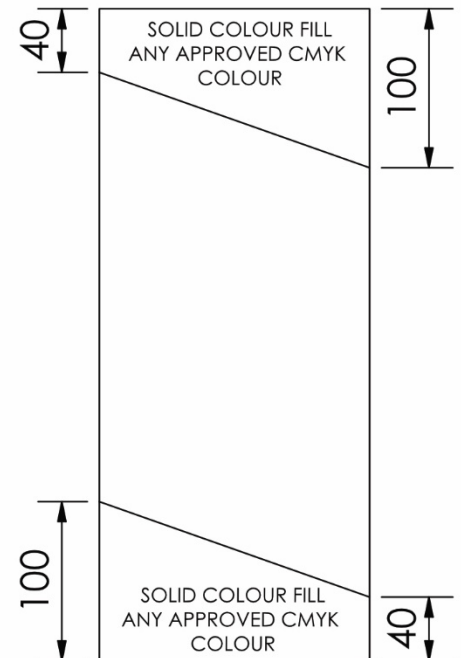

Images and text may be placed over solid colour fills, however, solid colour fills must not be completely covered.

Data sheet 9 – image bank

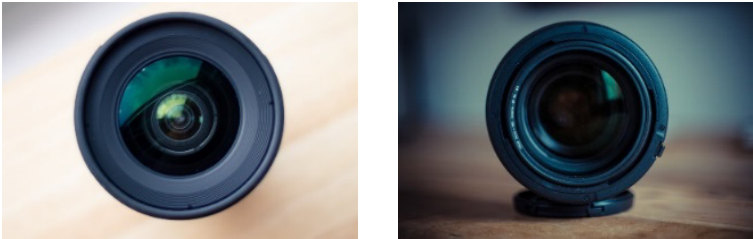
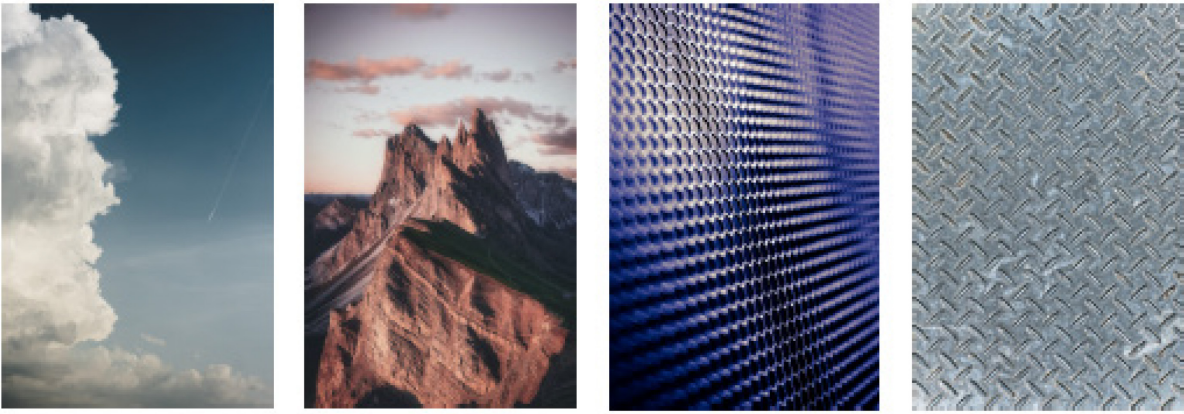
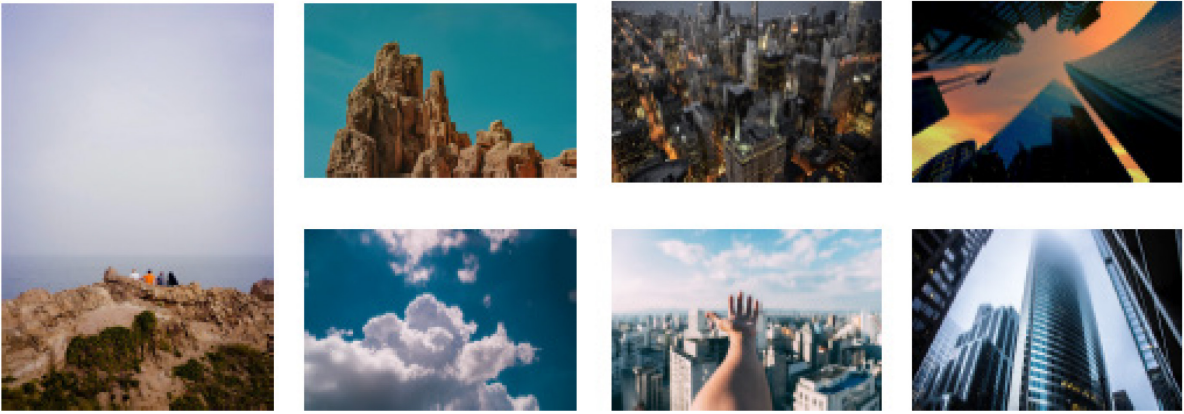
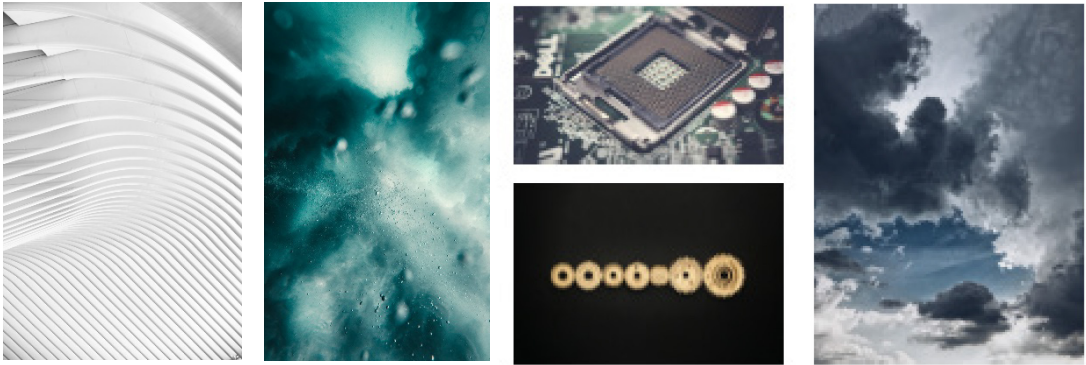

Data sheet 10 – copy text

COPY TEXT FOR PULL-UP BANNER

Model: GWP-060122

Maximum speed: 44 mph

Maximum flight time: 35 minutes

Follow me feature: available

Video recording function: available

Product weight: 1050g

The product includes extra batteries (x4 intelligent batteries), charging hub, controller cradle, and carry-bag. This model also comes with four additional propellers and spare filters.

The recommended AMP-2512 camera attachment records footage at 5.4k (60 fps). The high dynamic range camera allows “dark-scene” capture at high resolution and has sharing capability with a range of mobile devices. To view our full range of camera attachments, visit our website at www.certadronesuk.com.

COPY TEXT FOR BUSINESS CARD

Nat Cerroed, CEO
Victoria Road
Aberdeen, AB11 9NS
01224 123 456
www.certadronesuk.com

Data sheet 11 – controller cradle

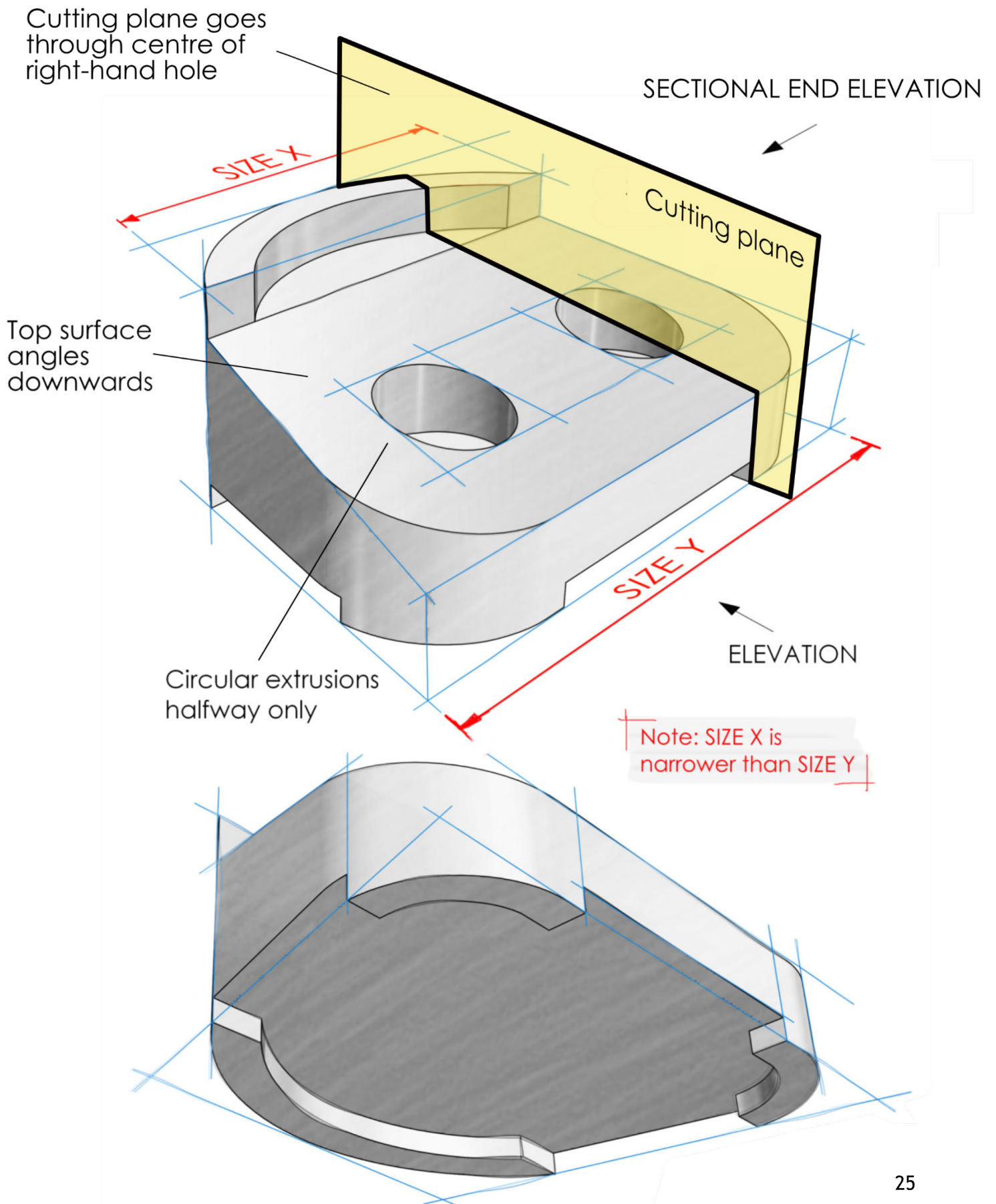

Copyright acknowledgements

Data sheet 9: various images – Creative Commons CC0 and sourced www.pexels.com

Administrative information

Published: January 2024 (version 1.1)

History of changes

Version	Description of change	Date
1.1	The final bullet in task 1b (and the associated data sheet 2) has been amended for clarification.	23/1/24

Note: you are advised to check SQA's website to ensure you are using the most up-to-date version of this document.

Security and confidentiality

This document can be used by SQA approved centres for the assessment of National Courses and not for any other purpose.

This document may only be downloaded from SQA's designated secure website by authorised personnel.

© Scottish Qualifications Authority 2024