



National  
Qualifications  
2024

---

## 2024 Graphic Communication

### Higher

## Question Paper Finalised Marking Instructions

© Scottish Qualifications Authority 2024

These marking instructions have been prepared by examination teams for use by SQA appointed markers when marking external course assessments.

The information in this document may be reproduced in support of SQA qualifications only on a non-commercial basis. If it is reproduced, SQA must be clearly acknowledged as the source. If it is to be reproduced for any other purpose, written permission must be obtained from [permissions@sqa.org.uk](mailto:permissions@sqa.org.uk).



## General marking principles for Higher Graphic Communication

*Always apply these general principles. Use them in conjunction with the specific marking instructions, which identify the key features required in candidates' responses.*

- (a) Always use positive marking. This means candidates accumulate marks for the demonstration of relevant skills, knowledge and understanding; marks are not deducted for errors or omissions.
- (b) If a candidate response does not seem to be covered by either the principles or detailed marking instructions, and you are uncertain how to assess it, you must seek guidance from your team leader.
- (c) For 'Describe' questions  
Candidates must provide a statement or structure of characteristics and/or features, not just an outline or a list. For example, they can refer to a concept, experiment, situation or facts in the context of and appropriate to the question. The number of marks available for a question indicates the number of factual/appropriate points required.
- (d) For 'Explain' questions  
Candidates must relate cause and effect and/or define relationships. This must be in the context of the question, or a specific area within the question.
- (e) For 'Compare' questions  
Candidates must demonstrate knowledge and understanding of the similarities and/or differences between things, methods, or choices. This must be in the context of the question, or a specific area within the question.
- (f) Candidates can respond to any question using text, sketching, annotations or combinations of these. Award marks for the information conveyed. Do not award marks for the quality of sketching.

## Marking Instructions for each question

Question		Expected response	Max mark	Additional guidance
1.	(a)	<ul style="list-style-type: none"> <li>• Square cropping has been used on the image with the orange car focusing on the headlight</li> <li>• Square cropping has been used to allow the image to fit the available space within the layout</li> <li>• Full cropping has been used on the images of the blue car removing the background to apply your own</li> <li>• Full cropping allows for text wrapping around the image</li> </ul>	2	<p>Specific reference to 'Square' and 'Full' is not required</p> <p>Accept reference to any image that has been square or fully cropped</p> <p>Do not accept references to 'crop to shape'</p>
	(b)	<ul style="list-style-type: none"> <li>• High resolution images allow for photorealistic images to be saved <b>as</b> each pixel can be a different colour, allowing for subtle changes in colour</li> <li>• Allows for rich and detailed images <b>due to</b> use of pixels over shapes</li> <li>• Common file format <b>that can be</b> opened in any software</li> <li>• Does not require specialist software to open <b>so can be</b> used almost anywhere and on any device</li> </ul>	2	
	(c)	<ul style="list-style-type: none"> <li>• The script fonts used ties in with the vintage theme of the promotional document</li> <li>• The 'chunky' serif font has a vintage feel to it, tying in with the theme</li> <li>• Contrasting fonts create visual interest</li> <li>• Repeated use of serif typeface on multiple pages creates unity</li> <li>• Reverse text draws attention to important information</li> </ul>	2	Multiple references to theme can only attract one mark
	(d)	<ul style="list-style-type: none"> <li>• Drop caps lead the readers eye to the start of a body of text <b>making the document</b> easy to follow</li> <li>• Drop caps emphasise the start of the text <b>which</b> draws readers attention</li> </ul>	1	

Question			Expected response	Max mark	Additional guidance
1.	(e)		<ul style="list-style-type: none"> <li>• It makes it easy for the graphic designer to align text boxes and images</li> <li>• It helps the graphic designer to implement a two column layout throughout the publication</li> <li>• It helps to create consistency/standardisation within the document's layout</li> <li>• Can be used in future documents</li> <li>• Saves time in setup/placement of items</li> </ul>	2	
	(f)		<ul style="list-style-type: none"> <li>• Placeholder text allows a graphic designer to create a layout before the final text has been decided on</li> <li>• Allows the designer to see how much space would be required for text</li> <li>• Placeholder text does not need to be manually typed</li> </ul>	1	
	(g)		<ul style="list-style-type: none"> <li>• Any valid example of unity <b><u>which creates</u></b> a coherent/joined up/planned layout</li> </ul>	1	Accept responses that refer to "orange and blue colour scheme/palette"
	(h)	(i)	<ul style="list-style-type: none"> <li>• Registration mark</li> </ul>	1	
		(ii)	<ul style="list-style-type: none"> <li>• To ensure multi-colour printing has aligned correctly</li> <li>• Used to support alignment in secondary machines such as cutters</li> </ul>	1	Follow on error applies if candidate refers to crop mark in (h) (i)

Question		Expected response	Max mark	Additional guidance
2.	(a)	<ul style="list-style-type: none"> <li>• Create the path with all dimensions (1 mark)</li> <li>• Create a profile of dia 12 on a perpendicular workplane (1 mark)</li> <li>• Extrude/Sweep along a path (1 mark)</li> <li>• On the front face create a new profile of dia 15 and extrude by 15 (1 mark)</li> <li>• Use the shell command, wall thickness 2 removing front face (1 mark)</li> <li>• On the front face, create a new profile of dia 2. Position of circle correct and use of radial array to repeat circle 8 times around 270 degrees (1 mark)</li> <li>• Extrude Subtract by 10 (1 mark)</li> </ul>	7	<p>Candidate must shell before creating radial array to access 5<sup>th</sup> bullet point</p> <p>If radial array is not used, candidates must state the angle between instances which is 38.58 degrees</p>
	(b)	<ul style="list-style-type: none"> <li>• Files can be accessed remotely from anywhere in the world</li> <li>• Allows for remote working</li> <li>• Files can be easily shared between coworkers</li> <li>• Allows for collaboration</li> <li>• Files can be encrypted</li> <li>• Requires no physical space</li> <li>• File restoration features (old versions/back-ups)</li> </ul>	2	
	(c)	(i)	1	
		(ii)	1	
	(d)	<ul style="list-style-type: none"> <li>• Within the modelling tree, select the profile on workplane 2 (1 mark)</li> <li>• Change the profile of the ellipse to a hexagon and set the size to 24 A/F (1 mark)</li> </ul>	2	<p>Candidate must edit the model tree and sketch to access these marks</p> <p>0 marks should be awarded if the candidate models the counterweight from scratch</p>

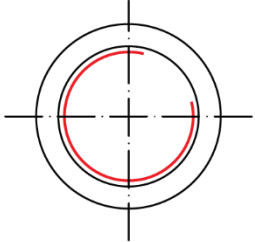
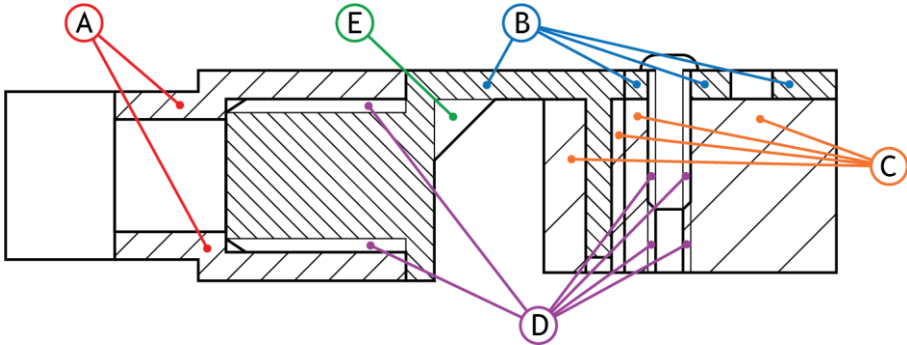
Question			Expected response	Max mark	Additional guidance
2.	(e)	(i)	 <p>END ELEVATION</p>	1	
		(ii)	<p>Areas A (1 mark)  Areas B (1 mark)  Areas C (1 mark)  Correct omission of threads D (1 mark)  Correct omission of web E (1 mark)</p> <p>Components with multiple areas hatched must have matching hatching style.</p> <p>Clear distinction between components should be reflected in the hatching style applied.</p>	5	
	(f)		<ul style="list-style-type: none"> <li>• Sizes and position of the holes of the needle cartridge <b>can be projected</b> from the tonearm head</li> <li>• The needle cartridge would be modelled in the correct position <b>and would not need</b> to be constrained into place</li> <li>• If changes made to one component, <b>this will dynamically</b> update all other components</li> </ul>	2	

Question			Expected response	Max mark	Additional guidance
2.	(g)		<ul style="list-style-type: none"> <li>• <b>Centre axis</b> the axle, the hole through the main arm and base</li> <li>• <b>Mate</b> one of the inner sides of the axle to one of the outside flat sides on the base</li> <li>• <b>Orientate</b> the main arm to an angle of 20 degrees</li> <li>• <b>Offset</b> of 13 the centre of the main arm to inner edge of base <u>or</u> <b>Mate</b> centre of main arm with centre workplane of model</li> </ul>	4	
	(h)	(i)	<ul style="list-style-type: none"> <li>• <math>15 - 1.5 = 13.5</math></li> <li>• <math>15 - 2.5 = 12.5</math></li> </ul>	2	Sum is not required
		(ii)	<ul style="list-style-type: none"> <li>• <math>4 + 1.5 = 5.5</math></li> <li>• <math>4 + 2.5 = 6.5</math></li> </ul>	2	Sum is not required
	(i)	(i)	<ul style="list-style-type: none"> <li>• Plan</li> </ul>	1	
		(ii)	<ul style="list-style-type: none"> <li>• End Elevation</li> </ul>	1	
		(iii)	<ul style="list-style-type: none"> <li>• Elevation</li> </ul>	1	

Question		Expected response	Max mark	Additional guidance
3.	(a)	<ul style="list-style-type: none"> <li>• Dia 3 profile, positioned 25 from axis (1 mark)</li> <li>• Use of helix command (1 mark)</li> <li>• 11 revolutions, pitch 20 or overall length of helix 220 <i>2 of 3 for</i> (1 mark)</li> </ul>	3	
	(b)	<ul style="list-style-type: none"> <li>• Profile 700 x 560 with R50 corners, extrude 80 (1 mark)</li> <li>• 460 x 600 rectangular profile (1 mark)</li> <li>• Workplane offset by 260 and the 260 square profile (1 mark)</li> <li>• Use of loft command (1 mark)</li> <li>• Correct production of vertical extrusion with reference to key sizes of 185, 580, 45 degrees and 260 (1 mark)</li> <li>• Shell removing three faces, wall thickness 20 (1 mark)</li> </ul>	6	
	(c)	<ul style="list-style-type: none"> <li>• Watermarking is a means of protecting the intellectual property of the company</li> <li>• It can act as an advertisement for the company</li> <li>• To stop others from selling or passing off the images as their own</li> <li>• Prevents use of image without payment being made</li> </ul>	2	Do not accept 'theft' or 'stealing' without a description
	(d)	<ul style="list-style-type: none"> <li>• Improves corporate image of business</li> <li>• Easier to work remotely</li> <li>• Easier to collaborate/share work with other people</li> <li>• Allows for smaller workspaces</li> <li>• Reduced cost from storage</li> <li>• Reduced cost from use of ink, toner or paper</li> </ul>	2	
	(e)	<ul style="list-style-type: none"> <li>• When viewing, the image can be enlarged for better clarity</li> <li>• Can be viewed in little or no light/dark</li> <li>• Can be shared instantly via email</li> <li>• Can store high number of photographs on one device</li> <li>• Can be copied onto promotional material/website</li> </ul>	2	

Question			Expected response	Max mark	Additional guidance
3.	(f)	(i)	<p><b>Explain Emphasis</b></p> <p><u>Cause:</u></p> <ul style="list-style-type: none"> <li>• Yellow/grey shape around perimeter of image</li> <li>• ‘Modernise’ or ‘quote’ in yellow/bold</li> <li>• Use of line and shape below or around company name to emphasise ‘Kalleta Kitchens’</li> <li>• White space around ‘Kalleta Kitchens’</li> <li>• Drop shadow applied to rectangular shape behind ‘Kalleta Kitchens’</li> </ul> <p><u>Effect:</u></p> <ul style="list-style-type: none"> <li>• Helps to make the image/text stand out against other elements</li> <li>• Draws the user’s attention to this image/piece of text</li> <li>• Creates hierarchy of importance/makes this one of the first things that the viewer sees/reads</li> </ul>	2	<p>One example of a <b>cause</b> with an <b>effect</b> will gain 1 mark</p> <p><b>Do not</b> accept emphasis as an effect</p>
		(ii)	<p><b>Explain Value</b></p> <ul style="list-style-type: none"> <li>• Low value yellow/grey around kitchen image <b>highlights</b> this image/draws user’s attention</li> <li>• Low value text for subheadings/ Kalleta Kitchens <b>highlights</b> most important text</li> <li>• Low value grey on shapes at bottom <b>helps make</b> these images stand out/contrast against background.</li> <li>• Higher value body text used to create hierarchy of importance <b>which</b> highlights that this text is less important than subheading text</li> <li>• High value grey around perimeter of body text <b>helps make</b> the images stand out more</li> <li>• Yellow gradient high to low value <b>highlights</b> the sequence at the bottom</li> <li>• High value yellow used on line <b>to make</b> this element less dominant</li> </ul>	2	<p>One example of a <b>cause</b> with an <b>effect</b> will gain 1 mark</p> <p>The candidate should demonstrate understanding of value - a colour with low levels of white saturation has low value and a colour with high levels of white saturation has high value. Greys and yellows should be referenced</p>

Question			Expected response	Max mark	Additional guidance
3.	(f)	(ii)	<b>(continued)</b>		
			<ul style="list-style-type: none"> <li>• High value yellow used on shapes below company name <b>to make</b> 'Kalleta Kitchens' font stand out/contrast</li> <li>• High value yellow in background makes this element less dominant in the layout/<b>helps make</b> other elements stand out</li> </ul>	2	
		(iii)	<b>Describe Rhythm</b> <ul style="list-style-type: none"> <li>• Repeated formatting of sub-headings</li> <li>• Numbering system for sequence</li> </ul>	2	
		(iv)	<b>Describe Proportion</b> <ul style="list-style-type: none"> <li>• The kitchen images are large elements on the layout</li> <li>• Subheading text/'Kalleta Kitchens' is large font size</li> <li>• Body text is small font size</li> <li>• Four shapes with numbers at bottom are proportionately the same size</li> <li>• Two triangular images are proportionately the same size</li> <li>• Grey icons are larger than their corresponding numbers</li> <li>• All elements are similarly sized</li> </ul>	2	
		(v)	<b>Describe Shape</b> <ul style="list-style-type: none"> <li>• Rotated shapes beneath 'Kalleta Kitchens' text</li> <li>• Triangular shaped images</li> <li>• Combination of different shapes used (rectangles, triangles, random shapes)</li> <li>• Range of different sized shapes used</li> <li>• Layering used on kitchen shapes</li> <li>• Layering used on rectangular shapes beneath Kalleta Kitchens text</li> <li>• The main shape outlines all given different colours</li> <li>• Simple shapes used for icons</li> </ul>	3	

Question		Expected response	Max mark	Additional guidance
4.	(a)	<p>Used to communicate:</p> <ul style="list-style-type: none"> <li>• Initial idea(s)</li> <li>• Colour schemes</li> <li>• Materials</li> <li>• Layout/location of features</li> <li>• Height/length/depth/size of the building</li> <li>• Proportion of features</li> </ul> <p>Easier to understand as not a technical graphic</p>	2	Any two
	(b)	<ul style="list-style-type: none"> <li>• Proposed building in relation to the property boundaries</li> <li>• Road name</li> <li>• Access paths</li> <li>• Site or house number</li> <li>• Size and position of the building</li> <li>• Position of drainage</li> <li>• Landscape elements</li> <li>• Gas, electrical and water supplies</li> <li>• Contours to show slope in land</li> <li>• Position of trees (existing, proposed, to be removed)</li> <li>• North Point symbol will show the direction the building is facing</li> <li>• Size of the building and site to scale</li> <li>• The parking or road layout on site</li> </ul>	3	BS Symbol names are not required
	(c)	(i)	2	<p>Do not accept one word answers. Must be a description related to the model</p> <p>Do not accept 'sited environment' - not relevant to this context</p>
		(ii)	1	

Question			Expected response	Max mark	Additional guidance
4.	(d)	(i)	<ul style="list-style-type: none"> <li>Insulation board</li> </ul>	1	
		(ii)	<ul style="list-style-type: none"> <li>Contours</li> </ul>	1	
	(e)	(i)	<ul style="list-style-type: none"> <li>Clearly shows the dimension from any one feature to the next</li> </ul>	1	
		(ii)	<ul style="list-style-type: none"> <li>Avoids risk of accumulated error</li> <li>All sizes relative to a datum edge</li> </ul>	1	
	(f)		<ul style="list-style-type: none"> <li>Method 1: common tolerance</li> <li>Method 2: symmetrical tolerance</li> </ul>	2	
	(g)		<ul style="list-style-type: none"> <li>Maximum: 82.5</li> <li>Minimum: 80.5</li> </ul>	2	
	(h)		<ul style="list-style-type: none"> <li>Trim tool used to remove lines from hexagons (1 mark)</li> <li>R15 fillet applied to correctly identified edges (1 mark)</li> <li>Offset 12 (1 mark)</li> </ul>	3	Clear identification of lines to be trimmed through sketch or written description

[END OF MARKING INSTRUCTIONS]