

FOR OFFICIAL USE



--	--	--	--	--	--

National  
Qualifications  
2024

Mark

--

**X835/76/01**

**Graphic Communication**

THURSDAY, 16 MAY

9:00 AM – 11:30 AM



\* X 8 3 5 7 6 0 1 \*

Fill in these boxes and read what is printed below.

Full name of centre

--

Town

--

Forename(s)

--

Surname

--

Number of seat

--

Date of birth

Day

--	--

Month

--	--

Year

--	--

Scottish candidate number

--	--	--	--	--	--	--	--	--	--

**Total marks — 90**

Attempt ALL questions.

**You may use a calculator.**

All dimensions are in mm.

All technical sketches and drawings use third angle projection.

You may use rulers, compasses or trammels for measuring.

In all questions you may use sketches and annotations to support your answer if you wish.

Write your answers clearly in the spaces provided in this booklet. Additional space for answers is provided at the end of this booklet. If you use this space you must clearly identify the question number you are attempting.

Use **blue** or **black** ink.

Before leaving the examination room you must give this booklet to the Invigilator; if you do not, you may lose all the marks for this paper.



\* X 8 3 5 7 6 0 1 0 1 \*

Total marks — 90  
Attempt ALL questions

MARKS DO NOT  
WRITE IN  
THIS  
MARGIN

1. A graphic designer created a flyer for a vintage car show.  
In questions 1 (a) to (h) you must refer to the layouts on the **supplementary sheet for use with question 1**.

Two of the images used in the flyer prior to being cropped are shown below.



- (a) Describe, giving **two** examples, how the use of cropping has enhanced the flyer.

2

---

---

---

---

The images used are in a raster file format.

- (b) Explain, giving **two** reasons, why a raster file format is used.

2

---

---

---

---



1. (continued)

(c) Describe, giving **two** examples, how the graphic designer has used typeface effectively throughout the flyer.

2

---

---

---

---

(d) Explain why drop caps have been used in the flyer.

1

---

---

(e) Describe **two** benefits to the graphic designer of using a master page when creating the flyer.

2

---

---

---

---

(f) Describe **one** reason for using placeholder text in a document.

1

---

---

(g) Explain, giving **one** example, why unity has been used in the layout.

1

---

---

[Turn over



1. (continued)

The UK Historical Community Presents

## The UK Vintage Car Show

Tour Dates	
Dates	Dates
Glasgow - 22/11/22	Newcastle - 19/1/23
Edinburgh - 24/11/22	Erskine - 24/1/23
Dumfries - 27/11/22	Paisley - 26/1/23
Brighton - 29/11/22	Liverpool - 2/2/23
London - 5/12/22	Bristol - 13/2/23
Aberdeen - 20/12/22	Leeds - 17/2/23
Dundee - 6/1/23	Cardiff - 21/2/23

It's a car show that spans over 100 years...

... Come and see the transformation of land travel.

Vintage Cars - Good Food - Friendly People

Tickets available from 11/10/2022

www.vintagecarshowuk.co.uk

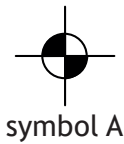

(h) (i) State the name of symbol A. 1

---

(ii) Describe the purpose of symbol A. 1

---



---



[Turn over for next question

DO NOT WRITE ON THIS PAGE



\* X 8 3 5 7 6 0 1 0 5 \*

2. An audio technology company are producing a new record player. A CAD technician was tasked with creating the 3D model of the record player tonearm shown below.

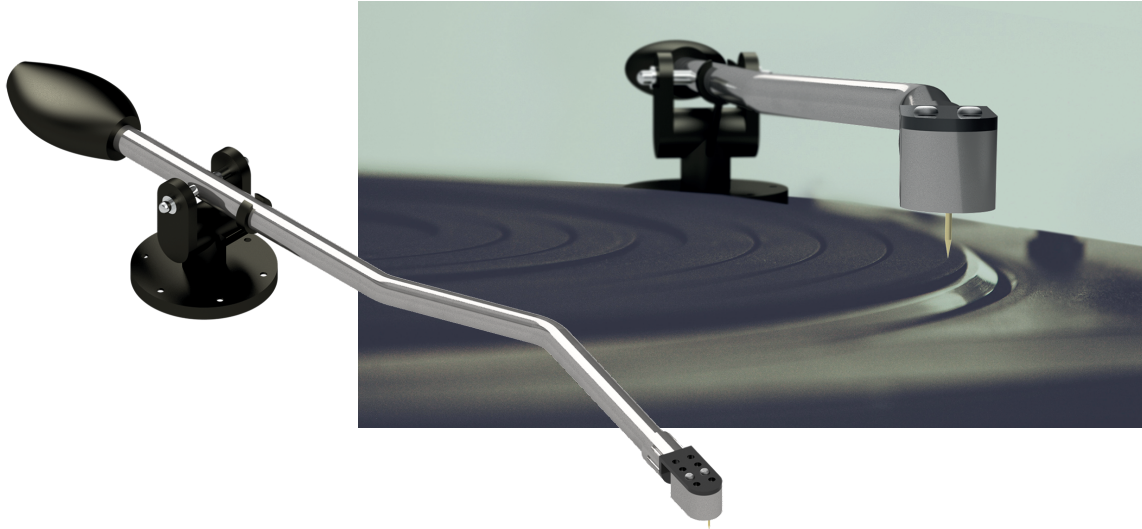

An exploded view and parts list are shown below.

PARTS LIST		
PART NUMBER	QTY	DESCRIPTION
1	1	Head
2	1	Needle
3	1	Main Arm
4	2	Fixing Screw
5	1	Needle Cartridge
6	1	Axle
7	1	Counterweight
8	1	Stand



2. (continued)

- (a) Describe the 3D CAD modelling techniques used to create the **main arm** component, shown opposite.

You must refer to the additional information and dimensions provided on **supplementary sheet for use with question 2 (a)** to answer this question.

You may use sketches to support your answer.

7



2. (continued)

The company uses a **cloud storage service**.

(b) Describe **two** advantages to the company of using cloud storage.

2

---



---



---



---

The company hires freelance CAD technicians to create 3D models. They all use different CAD software.

(c) (i) State a suitable file format the CAD technicians can use when sharing models.

1

---



---

(ii) Explain why using this file format is beneficial to the CAD technicians.

1

---



---



[Turn over for next question

DO NOT WRITE ON THIS PAGE



\* X 8 3 5 7 6 0 1 0 9 \*

2. (continued)

A CAD technician is asked to change the counterweight 3D model from Design 1 to Design 2.

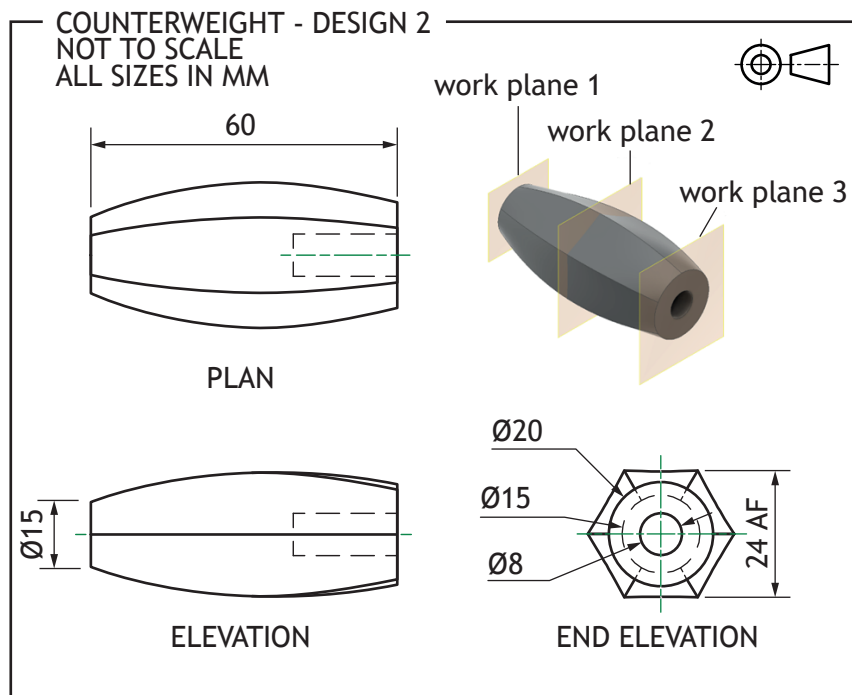
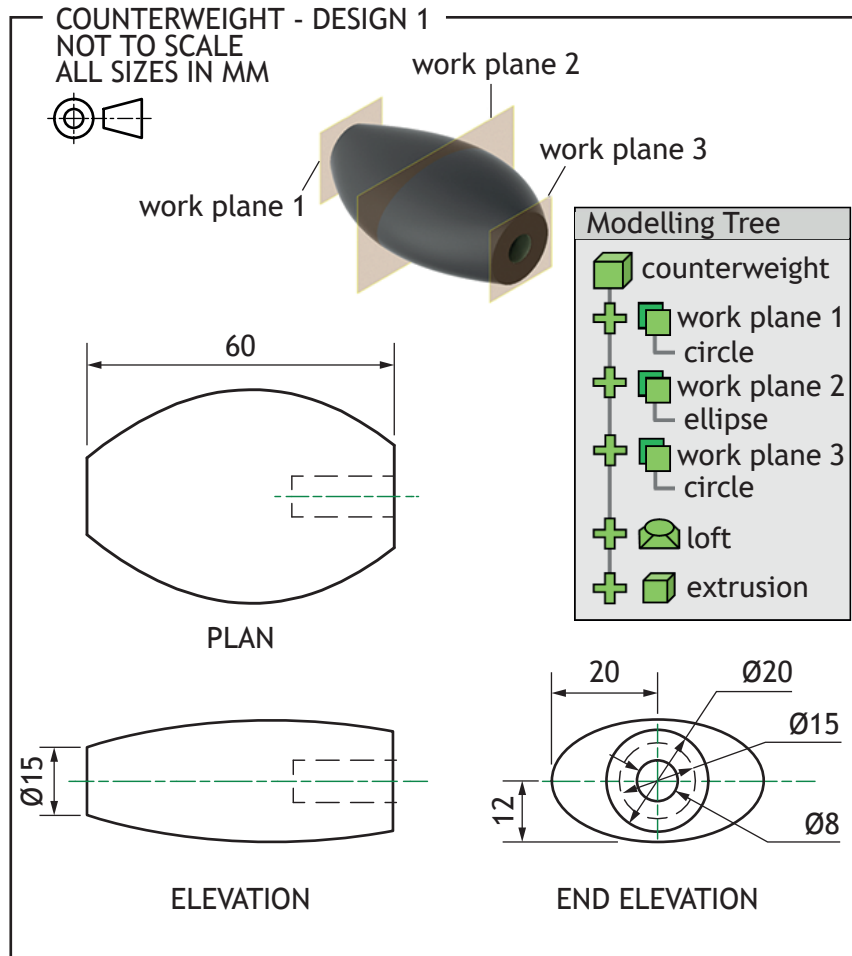

2. (continued)

(d) Describe, with reference to the modelling tree, how the CAD technician can edit the counterweight 3D model to make the change to the design.

You must make reference to the dimensions shown on the opposite page.

You may use sketches to support your answer.

2

[Turn over



\* X 8 3 5 7 6 0 1 1 1 \*

2. (continued)

An exploded view of the record arm head is shown below.

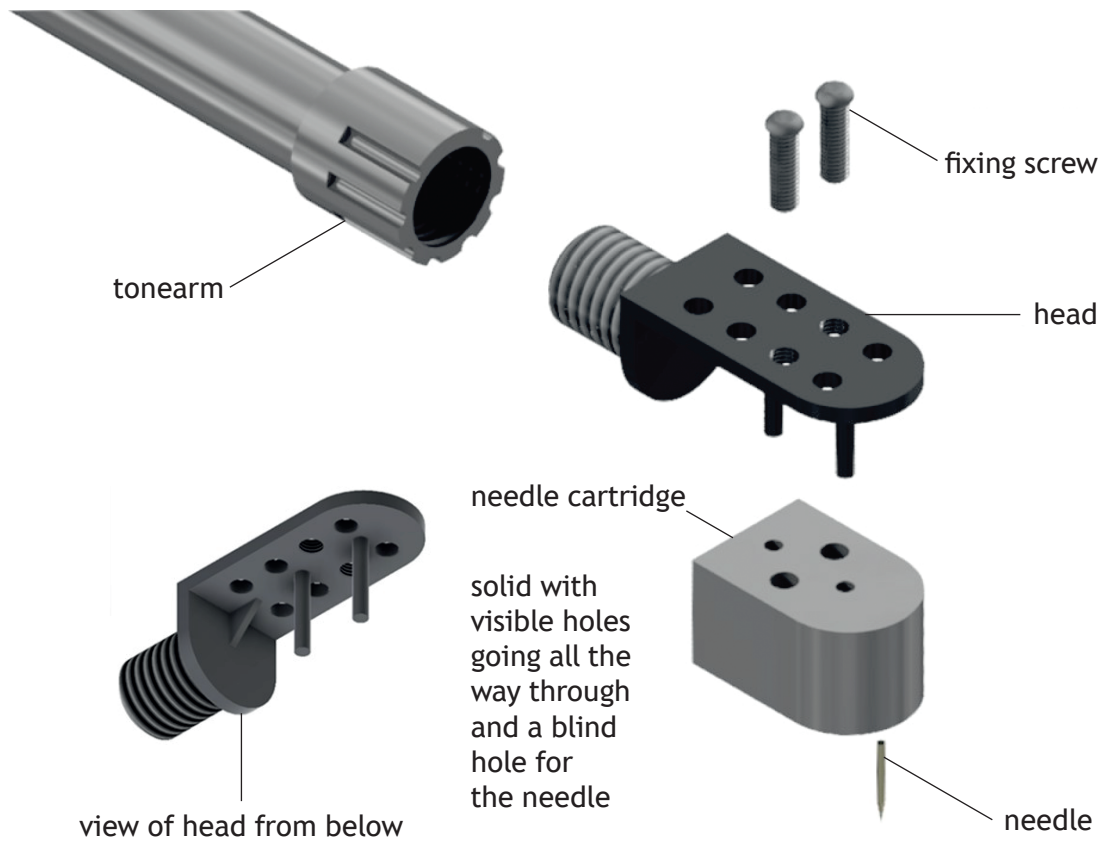

- (e) (i) Apply the British Standard convention for an external thread on the end elevation of the fixing screw.

1

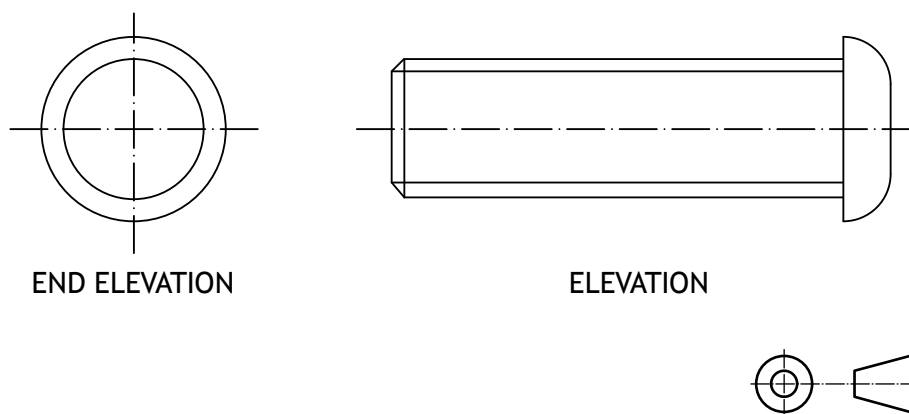

2. (e) (continued)

(ii) Apply hatching to Section A-A in accordance with British Standard conventions.

5

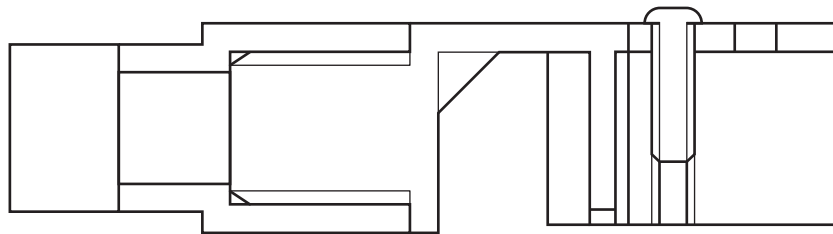
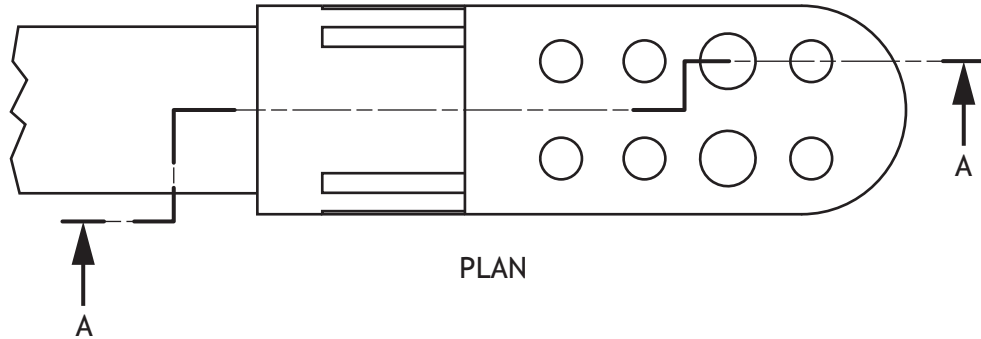

SECTION A-A

(f) Explain, giving **two** reasons, why using top-down modelling would benefit the CAD technician when modelling the needle cartridge.

2

---



---



---



---

[Turn over



2. (continued)

- (g) Describe, using 3D CAD terms, how to assemble and constrain the axle and main arm onto the base so that the main arm will sit at 20° to horizontal.

You may annotate the illustration and use sketches to support your answer.

4

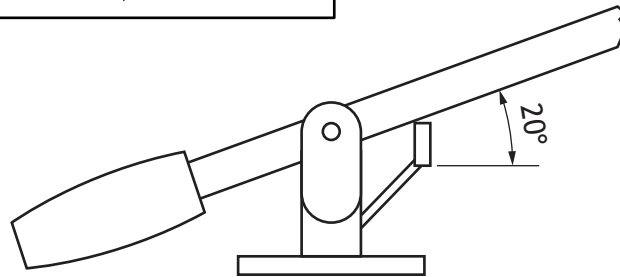
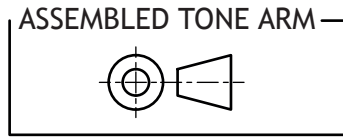

ELEVATION

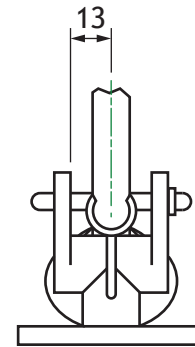

END ELEVATION

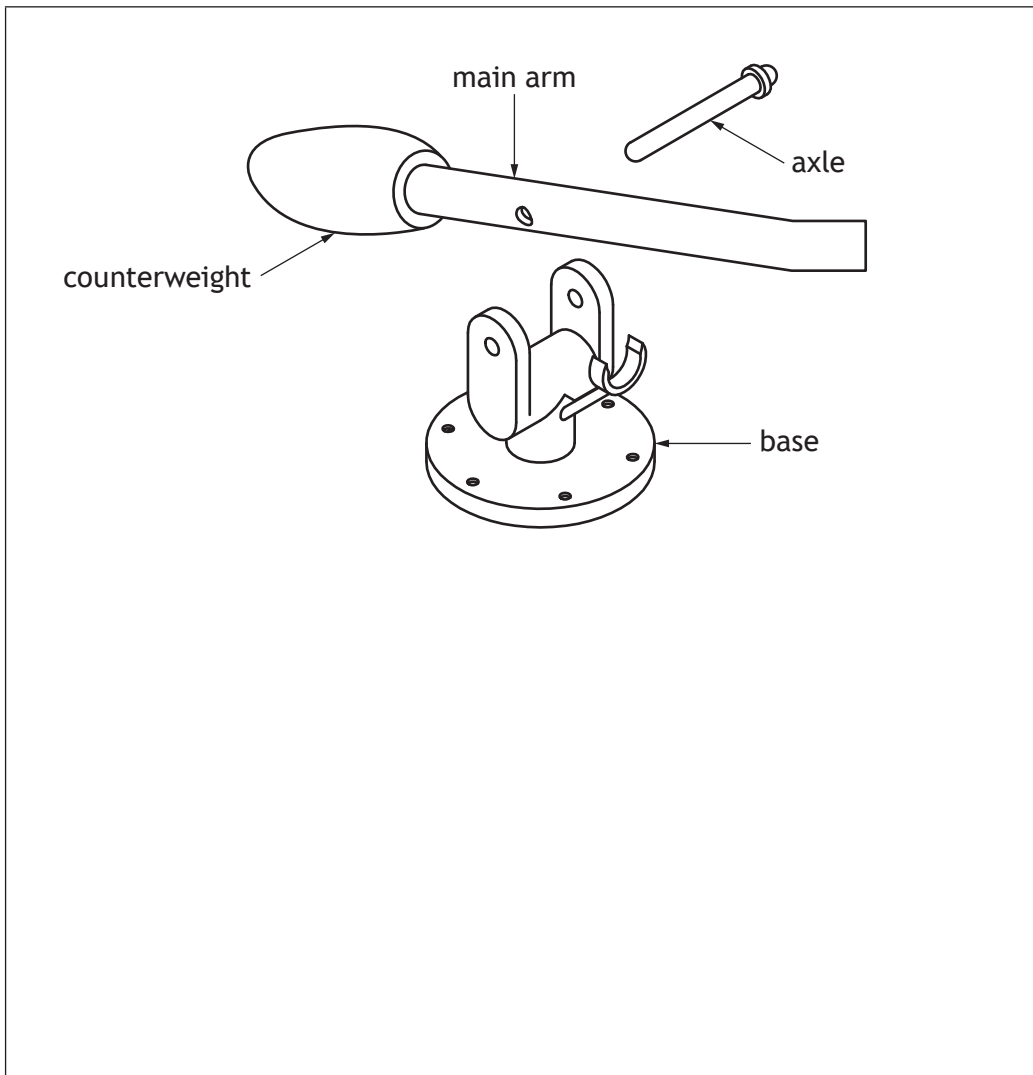

2. (continued)

A design for a handle for the tonearm is shown below. Tangency was used to create the design.

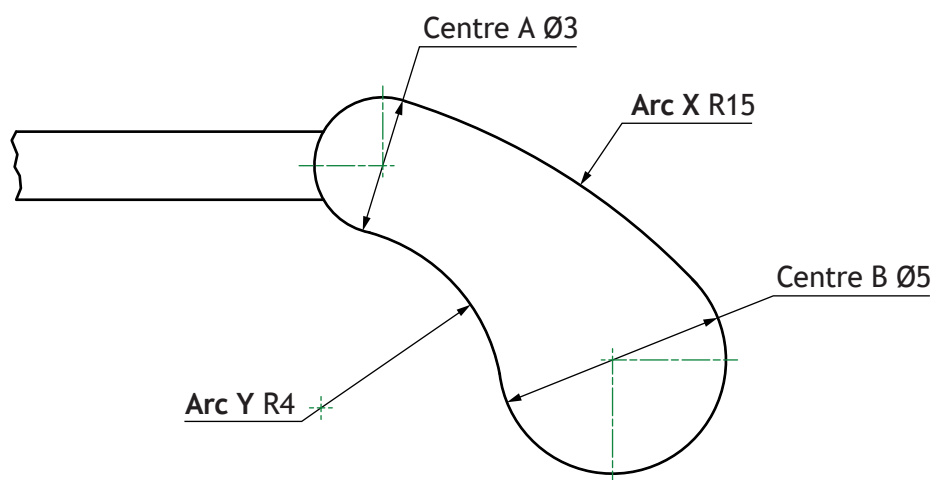

- (h) (i) Calculate the two radii required to find the centre point for Arc X. 2

- (ii) Calculate the two radii required to find the centre point for Arc Y. 2



2. (continued)

MARKS DO NOT WRITE IN THIS MARGIN

The designers created a 3D model of a speaker casing for the record player shown below.

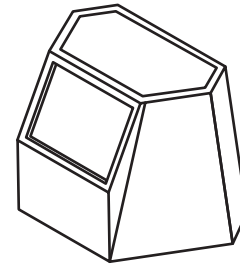
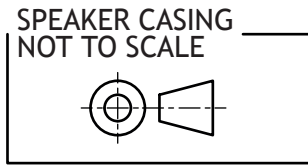

ISOMETRIC VIEW

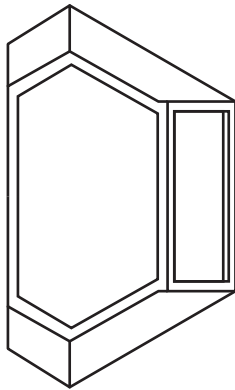

PLAN

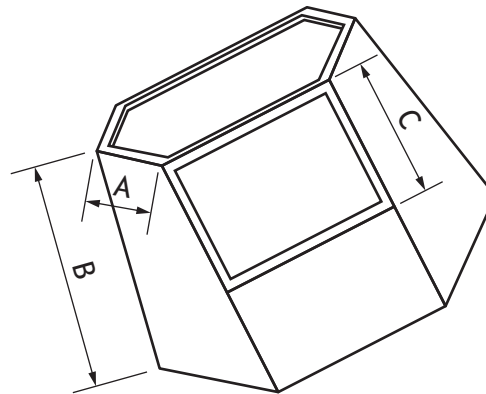

AUXILIARY PLAN X

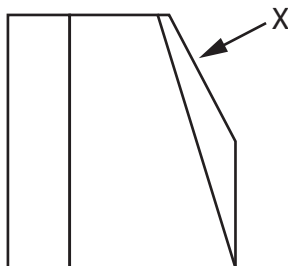

ELEVATION

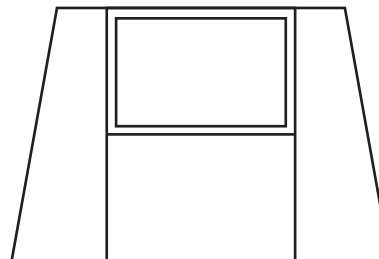

END ELEVATION

- (i) The auxiliary plan has dimensions A–C labelled.
- (i) State the name of **one** view where the true length for dimension A can be found. 1

---

  - (ii) State the name of **one** view where the true length for dimension B can be found. 1

---

  - (iii) State the name of **one** view where the true length for dimension C can be found. 1

---



3. A kitchen company is developing a range of new products. An orthographic drawing of a dish drying rack component is shown below.

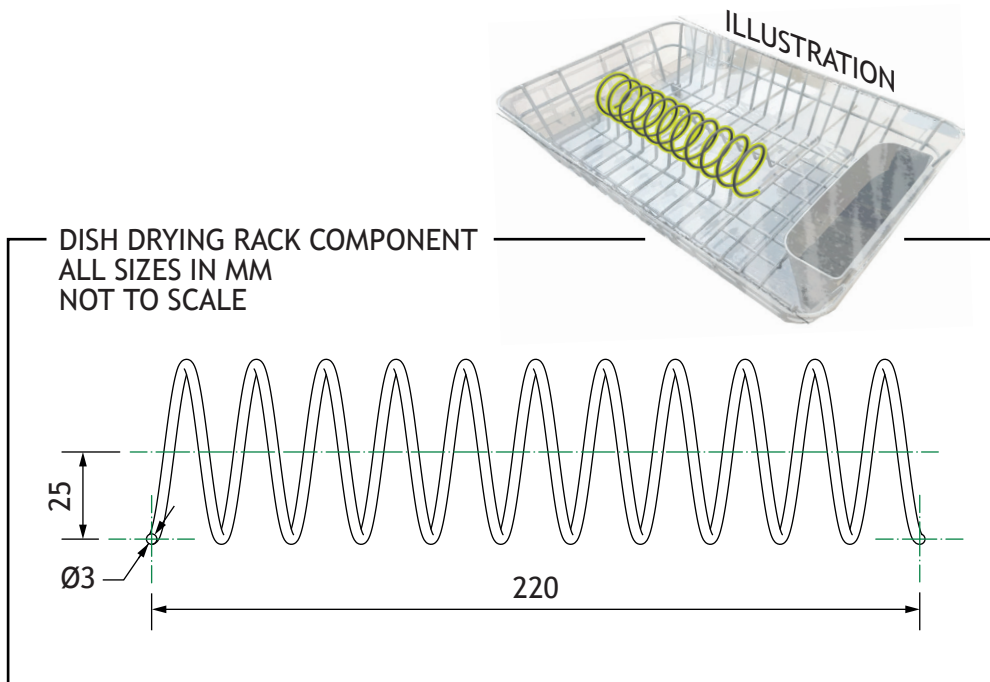

- (a) Describe the 3D CAD modelling techniques used to model the dish drying rack component. You must make reference to the dimensions given.

You may use sketches to support your answer.

3



3. (continued)

An orthographic drawing of a cooker hood concept is shown below.

DO NOT  
WRITE IN  
THIS  
MARGIN

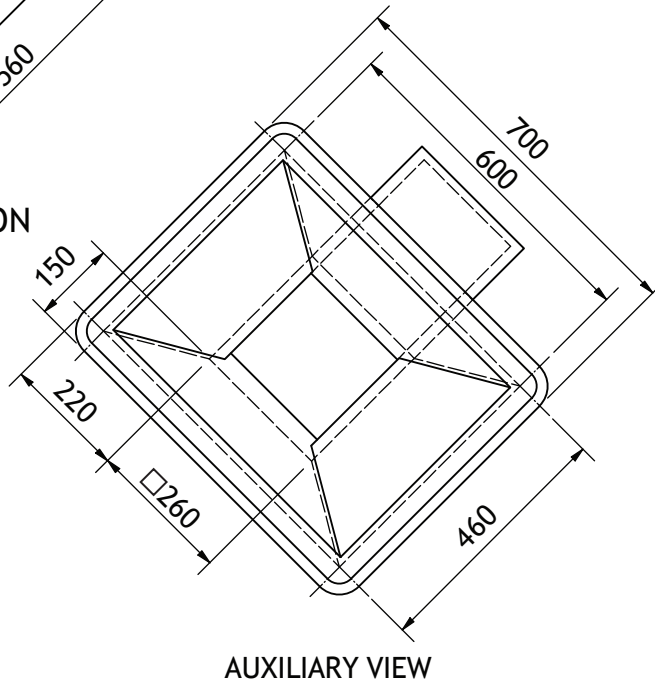
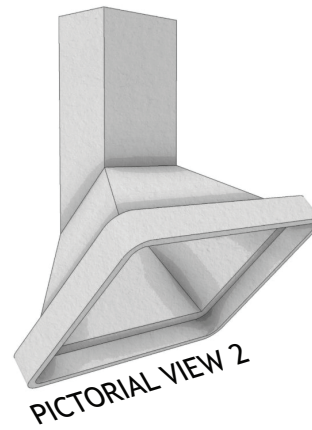
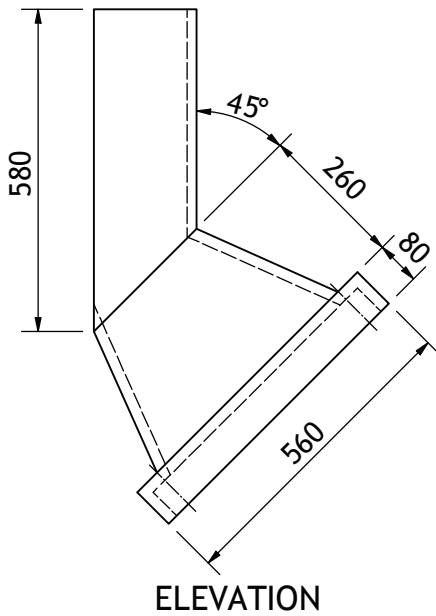
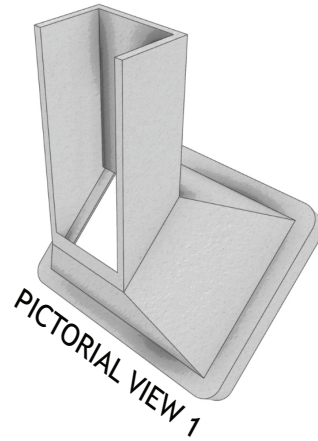
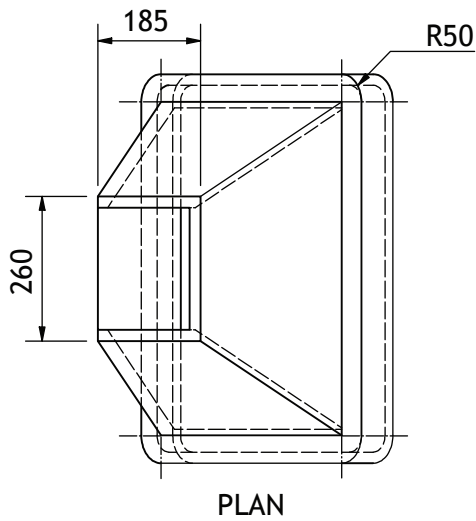

WALL THICKNESS 20

EXTRACTOR HOOD  
ALL SIZES IN MM  
NOT TO SCALE  
(SOME HIDDEN DETAIL  
REMOVED FOR CLARITY)

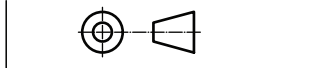

\* X 8 3 5 7 6 0 1 1 8 \*

3. (continued)

- (b) Describe the 3D CAD modelling techniques used to model the cooker hood. You must make reference to the dimensions given.

You may use sketches to support your answer.

6



3. (continued)

MARKS DO NOT WRITE IN THIS MARGIN

A photographer captured images for use on the kitchen company's website. Watermarked images were issued to the kitchen company. An example is shown below.



- (c) Describe **two** advantages to the photographer of applying watermarks to their images.

2

---

---

---

---

The photographer operates a **paperless office**.

- (d) Describe **two** advantages of operating a paperless office. **Do not** include environmental benefits.

2

---

---

---

---

The photographer sent digital versions of the samples to the kitchen company.

- (e) Describe **two** advantages for the kitchen company of viewing the images digitally compared to printed format.

2

---

---

---

---



3. (continued)

A new website is being commissioned by the kitchen company. A graphic artist has created a sample for one of the webpages.

In questions 3 (f) (i) to (v) you must refer to the layout on the **supplementary sheet for use with question 3 (f) (i) to (v)**.

- (f) (i) Explain, giving **two** examples, why the graphic artist has used emphasis to create an effective layout.

2

---



---



---



---

- (ii) Explain, giving **two** examples, why the graphic artist has used value to create an effective layout.

2

---



---



---



---

- (iii) Describe, giving **two** examples, how the graphic artist has used rhythm to create an effective layout.

2

---



---



---



---

[Turn over



3. (f) (continued)

(iv) Describe, giving **two** examples, how the graphic artist has used proportion to create an effective layout.

2

---

---

---

---

(v) Describe, giving **three** examples, how the graphic artist has used shape to create an effective layout.

3

---

---

---

---

---

---

---

---

---

---



4. A construction company has produced a range of graphics for the redevelopment of a community hub.  
One of the graphics is shown below.



Figure 1

- (a) Describe, giving **two** examples, how **Figure 1** could aid discussions with the client.

2

---



---



---



---

A site plan drawing of the community hub was produced.

- (b) Describe, giving **three** examples, the information that a site plan could communicate about the redevelopment to the local community.

3

---



---



---



---



---



---

[Turn over



4. (continued)

MARKS DO NOT WRITE IN THIS MARGIN

Illustrations highlighting an extension to the community hub are shown below.

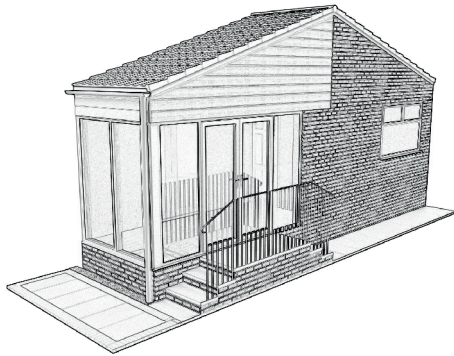

Illustration 1



Illustration 2

- (c) (i) Describe **two** 3D rendering techniques applied to produce the graphic shown in **Illustration 2**.

2

---

---

---

---

- (ii) Describe how a **sited environment** could be used to improve **Illustration 2**.

1

---

---

The symbols shown below were featured on some of the graphics produced for the redevelopment of the community hub.



symbol A

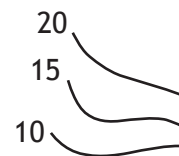

symbol B

- (d) (i) State the name of **symbol A**.

1

---

- (ii) State the name of **symbol B**.

1

---



4. (continued)

An orthographic drawing of a roof bracket used in the redevelopment is shown below.

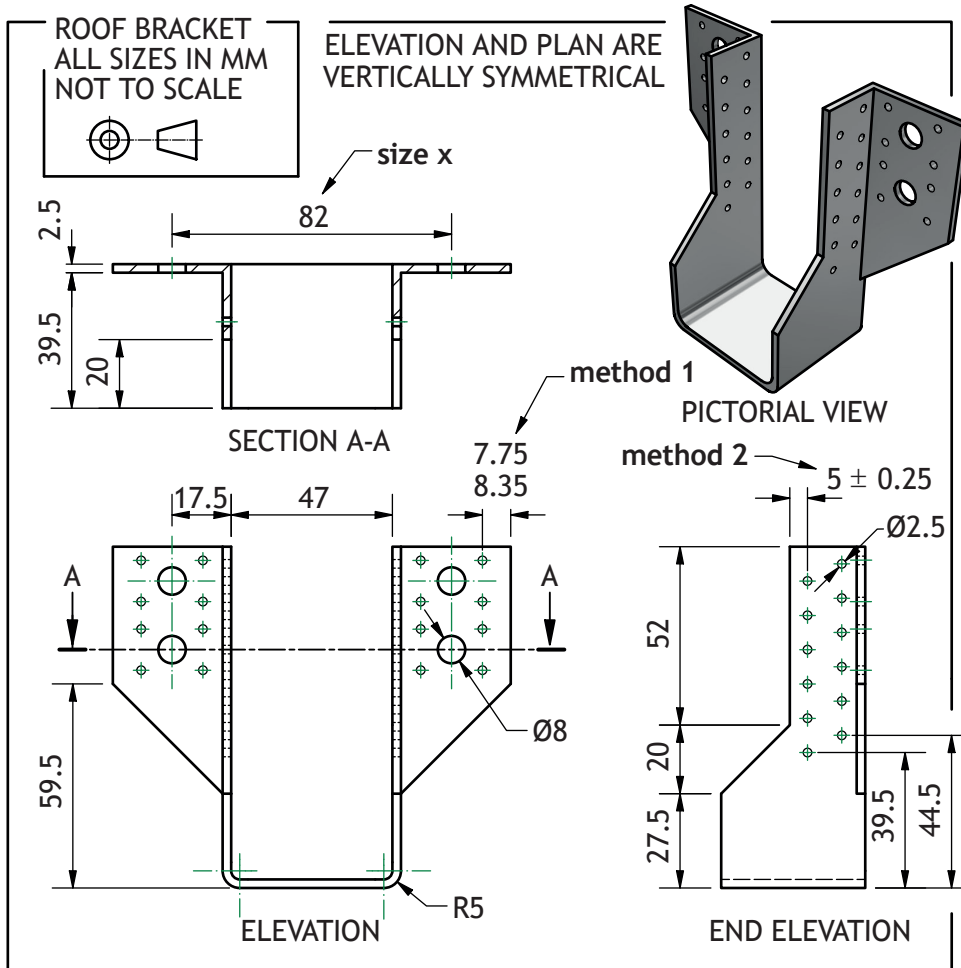

A combination of chain and parallel dimensioning has been used in the drawing.

(e) State an advantage of using chain and parallel dimensions in orthographic drawings.

(i) Chain dimensions

1

---



---

(ii) Parallel dimensions

1

---



---



4. (continued)

Different methods of dimensional tolerancing have been applied to the drawing of the roof bracket. These are labelled **method 1** and **method 2**.

- (f) State the British Standard term for each method.

2

Method 1 \_\_\_\_\_

Method 2 \_\_\_\_\_

- (g) Calculate the maximum and minimum dimension for size **x** with an allowable tolerance of: + 0.5  
- 1.5

2

Maximum = \_\_\_\_\_ Minimum = \_\_\_\_\_



4. (continued)

MARKS DO NOT WRITE IN THIS MARGIN

A 3D CAD model of a roof tile was produced for the redevelopment. Two stages in the production of this model are shown below.

- (h) Describe the 2D CAD techniques used to arrive from stage 1 to stage 2. You must make reference to the dimensions given.

You may use sketches to support your answer.

You may annotate the graphics below.

3

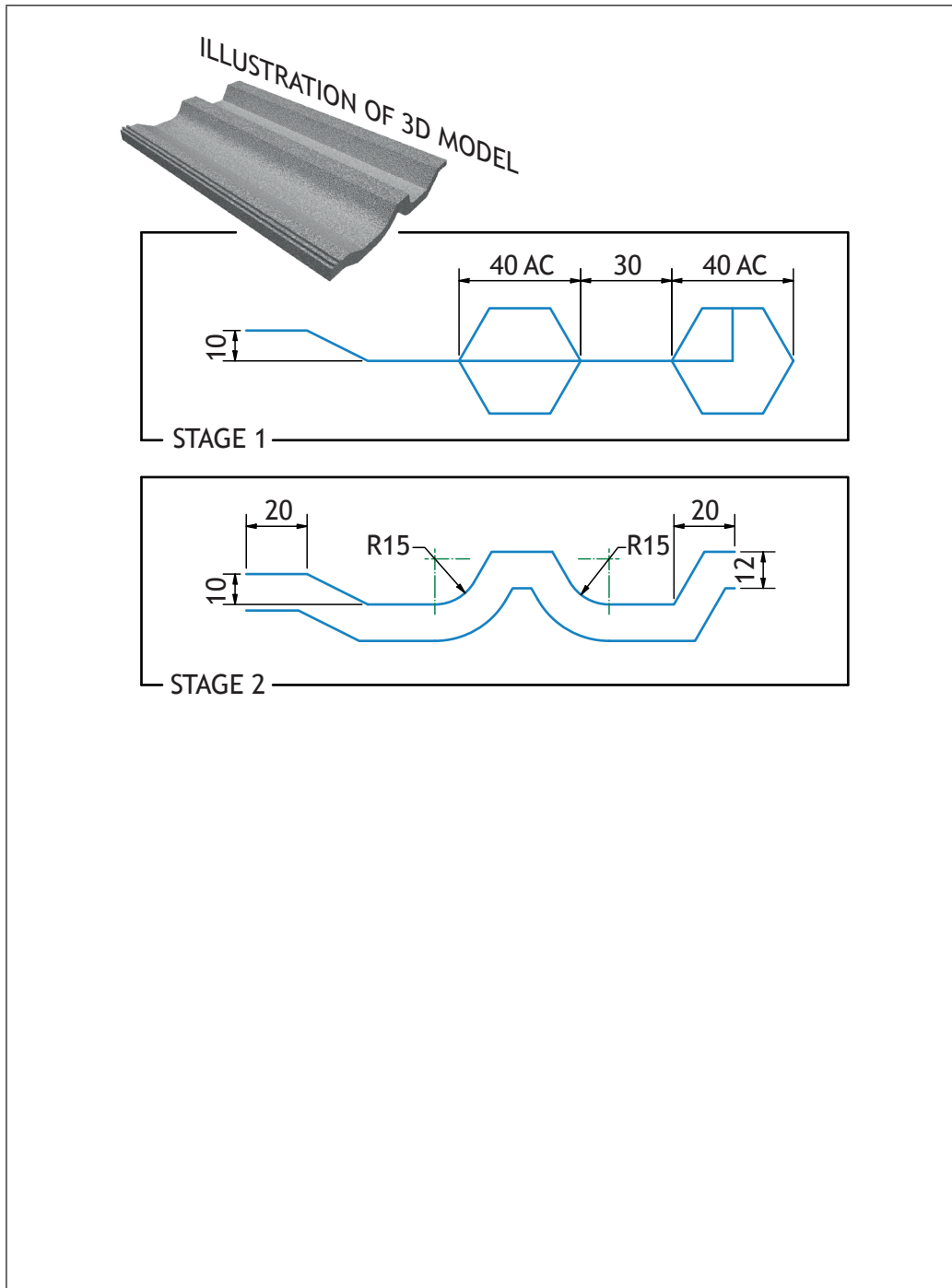

[END OF QUESTION PAPER]



MARKS DO NOT  
WRITE IN  
THIS  
MARGIN

ADDITIONAL SPACE FOR ANSWERS



\* X 8 3 5 7 6 0 1 2 8 \*

MARKS DO NOT  
WRITE IN  
THIS  
MARGIN

ADDITIONAL SPACE FOR ANSWERS



\* X 8 3 5 7 6 0 1 2 9 \*

[BLANK PAGE]

DO NOT WRITE ON THIS PAGE



\* X 8 3 5 7 6 0 1 3 0 \*

[BLANK PAGE]

DO NOT WRITE ON THIS PAGE



\* X 8 3 5 7 6 0 1 3 1 \*

[BLANK PAGE]

DO NOT WRITE ON THIS PAGE

*Acknowledgement of copyright*

Question 1      Image 1: George Sultan/Pexels.com  
                    Image 2: George Sultan/Pexels.com  
Question 1 (h)    Image 1: Pexels.com  
                    Image 2 (background): Pexels.com  
                    Image 3: Shukhrat Umarov/Pexels.com  
Question 2      Turntable background: Pexels.com



\* X 8 3 5 7 6 0 1 3 2 \*