



Higher Graphic Communication Assignment Assessment Task

This document provides information for teachers and lecturers about the coursework component of this course in terms of the skills, knowledge and understanding that are assessed. It must be read in conjunction with the course specification.

Valid for session 2024-25 only.

This assessment is given to centres in strictest confidence. You must keep it in a secure place until it is used.

This edition: January 2025 (version 1.1)

© Scottish Qualifications Authority 2025

Contents

Introduction	1
Instructions for teachers and lecturers	2
Instructions for candidates	6

Introduction

This document contains instructions for teachers and lecturers, and instructions for candidates for the Higher Graphic Communication assignment.

This assignment is worth 50 marks. This is 36% of the overall marks for the course assessment.

This is one of two course assessment components. The other component is a question paper.

Instructions for teachers and lecturers

You must conduct the assignment under a high degree of supervision and control. This means:

- ◆ candidates must be within your direct sight
- ◆ candidates must not interact with each other
- ◆ candidates must not have access to email, the internet and mobile phones
- ◆ candidates must complete their work independently – no group work is permitted
- ◆ classroom display materials that might provide assistance must be removed or covered
- ◆ with no interruption for learning and teaching
- ◆ in a classroom environment

Time

Candidates have 8 hours to complete the assignment, starting at an appropriate point in the course after all content has been delivered. Once candidates begin, they must continue in each subsequent class period until the permitted time allocation has been used up.

You have a responsibility to manage candidates' work, distributing it at the beginning and collecting it at the end of each session, and storing it securely in between. This activity does not count towards the total time permitted for candidates to complete the assignment.

Resources

This is a closed-book assessment. Candidates must not have access to learning and teaching materials, the internet, notes, exemplar materials, resources on classroom walls or anything similar.

There may be instances where restriction of internet and/or network use is prohibited (for example, if you have a local authority-managed network with specific limitations or CAD software that is web-based). However, it remains your professional responsibility to make every effort to meet the assessment conditions.

Each assessment task includes instructions and details of any equipment or materials required. Candidates can also use normal classroom equipment, software and hardware (such as CAD and DTP software, and PCs to run the software) to complete the tasks.

Candidates can use a pre-made or existing A3 CAD template.

Reasonable assistance

Candidates must progress through each stage of the assignment without your intervention or guidance, having acquired the skills earlier in the course.

Once candidates complete the assignment, you must not return it to them for further work. You must not provide feedback to candidates or offer an opinion on the perceived quality or completeness of the assignment response at any stage.

You can provide reasonable assistance to support candidates with the following aspects of their assignment:

- ◆ printing, collating, stapling and labelling their evidence to ensure it is in the format specified by SQA
- ◆ ensuring candidates have all the materials and equipment required to complete the assignment
- ◆ understanding the information in these instructions

Evidence

All candidate evidence (whether created manually or electronically) must be submitted to SQA in a paper-based format.

Each task details what evidence is required and how many pages are expected. This is a guide to ensure that candidates do not produce too much work or spend too long on a single task. Single-sided A3 pages are preferred and are typically the most suitable for the tasks; however, it is acceptable to submit A4 pages if an A3 printer is not available.

Each piece of work must be labelled with the task number, for example, task 3a, and the back of each page must be clearly labelled with candidate details.

Alteration or adaptation

You must not alter, adapt or modify the assignment in any way. This includes moving the content of the assignment into a different format or workbook. All candidates must undertake the assignment exactly as it is provided.

Volume

Candidates should present their work on a maximum of 10 single-sided A3-sized pages.

This figure is given to indicate the volume of evidence required; however, no penalty is applied where candidates exceed this. Full details of evidence requirements are contained within each assessment task.

Specific instructions for teachers and lecturers

You must follow these specific instructions. You must ensure that candidates are aware of the assessment conditions and know what they should do for each task.

Prior to candidates starting the assignment, you must download the following electronic files for their use. You must keep these files secure and candidates must not access them prior to assessment.

- ◆ data sheet 1 – STEP file of a ticket scanner
- ◆ data sheet 7 – STEP files of walls and floor, a waterbase sign, and a bin
- ◆ data sheet 7 – a decal graphic for a waterbase sign
- ◆ data sheet 8 – three graphics of a company logo (svg and png)
- ◆ data sheet 8 – copy text
- ◆ data sheet 9 – three graphics of dinosaurs
- ◆ data sheet 9 – three graphics of forests
- ◆ data sheet 9 – two graphics of a VR arcade
- ◆ data sheet 9 – two graphics of roller coasters
- ◆ data sheet 9 – a graphic of ground texture
- ◆ data sheet 9 – a selection of dinosaur-themed graphics (svg and png)
- ◆ data sheet 9 – a graphic of a queue-jump wristband
- ◆ data sheet 9 – a graphic of a mobile phone
- ◆ data sheet 9 – a graphic of a restaurant

This assignment has three tasks. Candidates must complete the tasks in order.

Each task has a notional time allocated to it.

Task 1 – 20 marks

(suggested time 3 hours)

- ◆ Tasks a to d: candidates must produce production drawings electronically. Candidates must generate these production drawings from a 3D CAD model they have produced.

Task 2 – 26 marks

(suggested time 4 hours)

- ◆ Task 2a: candidates must complete this task electronically.
- ◆ Task 2b: candidates can complete this task manually or electronically.
- ◆ Task 2c: candidates must complete this task electronically.

Task 3 – 4 marks

(suggested time 1 hour)

- ◆ Candidates are expected to complete this task manually. If they use an electronic method, it must not be 3D CAD software. Candidates will gain no marks if they use this software. If candidates use electronic sketching software, they are only allowed to use a straight edge. No other tools are allowed.

Note: candidates must not trace drawings for any part of the assignment. They will gain no marks for traced drawings.

All electronically generated evidence must be printed and compiled for uplift by SQA.

Instructions for candidates

This assessment applies to the assignment for Higher Graphic Communication.

This assignment is worth 50 marks. This is 36% of the overall marks for the course assessment.

It assesses the following skills, knowledge and understanding:

- ◆ creativity when responding to graphic design tasks and situations
- ◆ using graphic communication technologies to meet a purpose
- ◆ producing preliminary, production and promotional graphic items in response to a situation or problem
- ◆ applying illustration and presentation techniques to create graphics with relevant visual impact
- ◆ producing 2D and 3D production drawings, applying appropriate standards, protocols and conventions
- ◆ producing promotional graphic publications to meet an agreed content and style

Note: you must not trace drawings for any part of the assignment – you will gain no marks for traced drawings.

In this assessment, you have to produce a range of graphics in response to a brief:

- ◆ in the order presented
- ◆ that assesses aspects of the skills and knowledge listed above
- ◆ in 8 hours, excluding the time you need to set up and clear away any equipment you use, and for any printing you need to do

You must not use any text, images, or other items from any other source unless you create them during this 8-hour assignment.

There are three tasks, with marks allocated as follows:

Task 1 – 20 marks: producing production drawings for a turnstile
(suggested time 3 hours)

Task 2 – 26 marks: producing promotional graphics for a theme park entrance and a promotional poster
(suggested time 4 hours)

Task 3 – 4 marks: producing preliminary graphics for a queue-jump wristband
(suggested time 1 hour)

Your teacher or lecturer will provide you with:

- ◆ tasks sheets 1 to 3
- ◆ data sheets 1 to 10
- ◆ STEP files of a ticket scanner, walls and a floor, a waterbase sign, and a bin
- ◆ electronic files of the graphics shown on data sheet 7, 8 and 9

Assessment conditions

This is a closed-book assessment. You must undertake the assignment under a high degree of supervision and control. This means:

- ◆ you must be within direct sight of your teacher or lecturer
- ◆ you must not interact with other candidates
- ◆ you must not have access to email, the internet and mobile phones
- ◆ you must complete your work independently – no group work is permitted

You have 8 hours to complete the assignment. Once you begin, you must continue in each subsequent class period until the permitted time allocation has been used up.

Reasonable assistance

You must progress through each stage of the assignment without intervention or guidance from your teacher or lecturer.

Once you have completed the assignment, your teacher or lecturer cannot return it to you for further work. They will not give you feedback on your assignment response at any stage.

They can give you reasonable assistance to support with the following aspects of your assignment:

- ◆ printing, collating, stapling and labelling your evidence to ensure it is in the format specified by SQA
- ◆ ensuring you have all the materials and equipment required to complete the assignment
- ◆ understanding the information in these instructions

Submitting your work

You must label each piece of evidence with the task number (for example task 1a), and the back of each page with your:

- ◆ name
- ◆ date of birth
- ◆ Scottish Candidate Number (SCN)
- ◆ centre name
- ◆ centre number

Graphic Communication brief

A local theme park is updating the park and its advertising.

The theme park owners have requested a range of graphics for:

- ◆ a new turnstile
- ◆ the theme park entrance
- ◆ a promotional poster
- ◆ a queue-jump wristband

They have asked you to create:

- ◆ production drawings to manufacture the turnstile
- ◆ a 3D-illustrated environment that showcases the theme park entrance
- ◆ a promotional poster with relevant desktop-published graphics

They have given you:

- a selection of company logos and colours
 - copy text
 - several pre-approved promotional images
- ◆ preliminary sketches of a queue-jump wristband

Use the data sheets provided to guide you through the assignment.

Task 1: turnstile

A CAD technician has prepared a series of draft CAD drawings to help with the manufacture of the turnstile.

Using the draft CAD drawings and information on data sheets 1, 2, 3, 4, 5 and 6, model the turnstile components using 3D CAD software.

From these models, produce production drawings based on the turnstile shown.

You may use top-down modelling or bottom-up modelling in your work.

For all drawings in task 1, you must:

- ◆ use the same orientation as the orthographic views on each data sheet
- ◆ have correctly labelled views with an appropriate font size
- ◆ include the following British Standard conventions:
 - linear (parallel and chain as appropriate), radial, diameter and angular dimensions
 - the third-angle projection symbol, where appropriate
 - a title block including relevant information
- ◆ include hidden detail, appropriate dimensions for manufacture, and annotations, unless stated

- 1a (i) Produce an elevation, a plan and an end elevation of the body (part 1), as shown on data sheet 3. You must produce all views at a scale of 1:10.

Your drawing must include:

- ◆ the detail view, at a scale of 1:4, of the slot including key dimensions

(4 marks)

- (ii) Produce a plan, a sectional elevation and an end elevation of the swivel (part 2), as shown on data sheet 4. You must produce all views at a scale of 1:2.

Your drawing must include:

- ◆ the sectional elevation through cutting plane A-A
- ◆ the detail view, at a scale of 1:1, of one of the 30 x 30 squares from the plan view
- ◆ a minimum of four dimensions applied to the detail view
- ◆ hidden detail on the plan and end elevation

(5 marks)

- 1b Produce an assembled drawing of the turnstile as shown on data sheet 2. You must produce all views at a scale of 1:10.

The ticket scanner (part 5) has been provided for you as a step file.

Your drawing must include:

- ◆ an elevation and a plan view
- ◆ a sectional end elevation through cutting plane X-X, as shown on data sheet 2
- ◆ a stepped sectional end elevation through cutting plane Y-Y, as shown on data sheet 2
- ◆ a detail view, at a scale of 1:4, to show how the body (part 1), the swivel (part 2), the arm (part 3), and the ticket scanner (part 5) fit together

Do not include dimensions or hidden detail.

(6 marks)

- 1c Produce an exploded isometric view of the assembled turnstile from task 1b.

- ◆ do not show hidden detail
- ◆ you must produce the view as a line drawing
- ◆ you must not render the exploded view

(2 marks)

- 1d Include British Standard conventions and line types in all of your drawings.

- ◆ linear (chain and parallel), radial, diameter and angular dimensions as appropriate
- ◆ third angle projection symbol and title block including relevant information
- ◆ correctly labelled views

(3 marks)

Note: you must create all the production drawings for task 1 electronically and print out all your work.

You should complete task 1 on four or five single-sided A3-sized pages.

You should spend approximately 3 hours on task 1.

Your completed assignment (tasks 1 to 3) should be on no more than 10 single-sided A3-sized pages.

Task 2: preliminary and promotional graphics

The theme park owners are planning a new entrance layout and a promotional poster.

Data sheets 7, 8 and 9 contain information on a 3D computer-rendered environment of the entrance layout and a proposed promotional poster.

The theme park owners have asked you to create:

- ◆ a 3D computer-rendered environment of the new entrance layout that includes the assembled drawing of the turnstile you created in task 1
- ◆ relevant graphics for a promotional poster, which effectively promotes the company

They have given you:

- a selection of company logos and colours
- copy text
- several pre-approved promotional images

Note: you cannot alter the company name, logos, or company colours.

- 2a Using the assembled turnstile you created in task 1, produce a pictorial illustration of the theme park entrance.

You must produce a high-quality pictorial illustration from the viewpoint shown on data sheet 7. This must be a render, not a screen grab.

Your illustration must be free from pixilation and grain. Your application of lighting must be high quality.

Your illustration should be printed on a landscape sheet and must be scaled to fit the entire page.

Your illustration must include:

- ◆ the STEP files – the walls and floor, the waterbase sign, and the bin, they must be in the same position as the viewpoint on data sheet 7
- ◆ the turnstile from task 1b placed 4 times in the same positions as the viewpoint on data sheet 7
- ◆ appropriate colours or materials to meet the specifications for each STEP file, from data sheets 1 and 7
- ◆ appropriate colours or materials to meet the specifications for the turnstile, from data sheet 1
- ◆ a poster decal on to the waterbase sign from data sheet 7
- ◆ appropriate highlights and shadows

(9 marks)

- 2b Produce **two** preliminary layouts/ thumbnails of the promotional poster, using data sheets 8 and 9.

Both of your preliminary layouts/ thumbnails should have a divide between section 1 and section 2, as shown on data sheet 8.

Identify the use of **two** design elements and principles in your preliminary layouts/ thumbnails from this list:

- | | | |
|-------------|------------------|-------------------|
| ◆ alignment | ◆ emphasis | ◆ shape |
| ◆ balance | ◆ grid structure | ◆ texture |
| ◆ contrast | ◆ line | ◆ unity/proximity |
| ◆ depth | ◆ proportion | ◆ value |
| ◆ dominance | ◆ rhythm | ◆ white space |

You must also identify the use of two DTP terms and techniques:

- ◆ cropping (square or full cropping)
- ◆ drop caps
- ◆ flow text along a path
- ◆ reverse
- ◆ transparency
- ◆ text wrap

Your preliminary layouts/ thumbnails must also include:

- ◆ the copy text from data sheet 8
- ◆ two approved contrasting fonts from data sheet 8
- ◆ one company logo from data sheet 8
- ◆ a minimum of three CMYK colours from data sheet 8
- ◆ at least three images from data sheet 9

You only need to identify your chosen design elements and principles and DTP terms and techniques once in your preliminary layouts.

You can add other graphic items as long as you create them within the 8 hours of this assignment.

You can use the images on data sheet 9 as they are, or you can edit them to suit your design.

(6 marks)

2c Produce a final version of a desktop-published promotional poster at a scale 1:3, using data sheets 8 and 9.

The poster must demonstrate your skill in using design elements and principles and DTP terms and techniques. It should have a high level of visual impact.

Your poster should have a clear divide between section 1 and section 2, as shown on data sheet 8.

The poster must include:

- ◆ effective use of your chosen design elements and principles from task 2b
- ◆ effective use of your chosen DTP terms and techniques from task 2b
- ◆ the copy text from data sheet 8
- ◆ effective use of two approved contrasting fonts from data sheet 8
- ◆ one company logo from data sheet 8
- ◆ a minimum of three CMYK colours from data sheet 8
- ◆ at least three images from data sheet 9

You can add other graphic items as long as you create them within the 8 hours of this assignment.

You can use the images on data sheet 9 as they are, or you can edit them to suit your design.

(11 marks)

You must produce task 2a and 2c electronically and print out all your work.

Task 2b can be produced either manually or electronically.

You should complete task 2 on three single-sided A3-sized pages.

You should spend approximately 4 hours on task 2.

Your completed assignment (tasks 1 to 3) should be on no more than 10 single-sided A3-sized pages.

Task 3: preliminary graphics

A CAD technician has prepared a draft CAD drawing of a proposal for a queue-jump wristband.

Using the graphic on data sheet 10, produce a preliminary graphic to showcase this proposal.

Do not create a computer-generated technical graphic and then reproduce it as a manual sketch. **You will not gain any marks if you measure, trace, or use any drawing instruments (other than a straight edge). If you use an electronic method, it must not be 3D CAD software. You will gain no marks if you use this software.**

- 3 Produce a preliminary **orthographic** sketch of the queue-jump wristband using data sheet 10.

Your orthographic sketch must:

- ◆ represent the queue-jump wristband shown in the draft CAD drawing on data sheet 10
- ◆ include an elevation and a plan of the queue-jump wristband in the orientation shown on data sheet 10
- ◆ be produced in third-angle projection
- ◆ include hidden detail

You must not include centre lines, colour, highlights or shadows.

(4 marks)

Note: if you complete task 3 electronically you must print out all your work.

You should complete task 3 on one single-sided A3-sized page.

You should spend approximately 1 hour on task 3.

Your completed assignment (tasks 1 to 3) should be on no more than 10 single-sided A3-sized pages.

Data sheet 1 - assembled turnstile illustration

PARTS LIST			
ITEM	QTY	PART NAME	MATERIAL
1	1	Body	Metal
2	1	Swivel	Metal
3	3	Arm	Green
4	1	Base	Metal
5	1	Ticket Scanner (STEP FILE)	Green

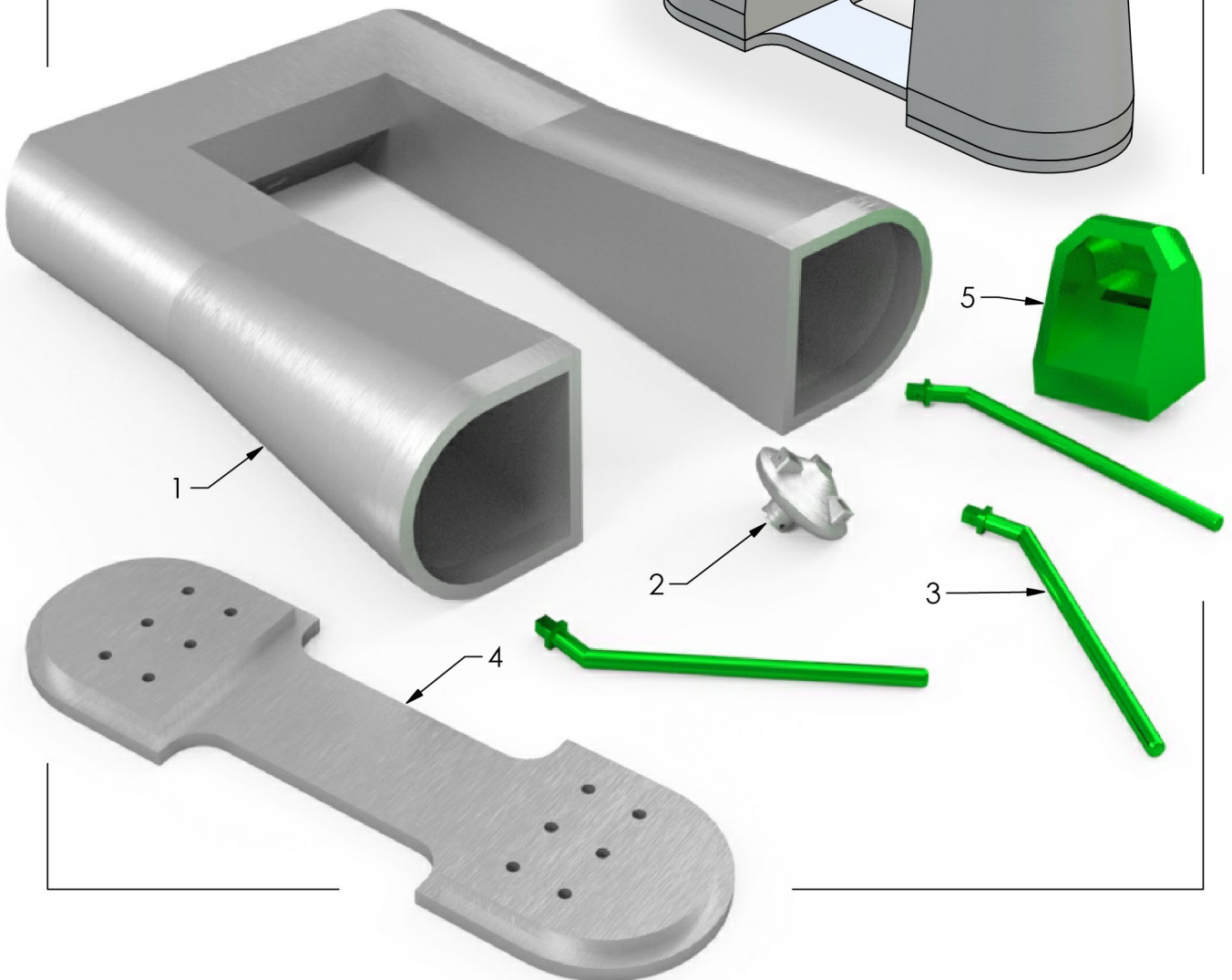
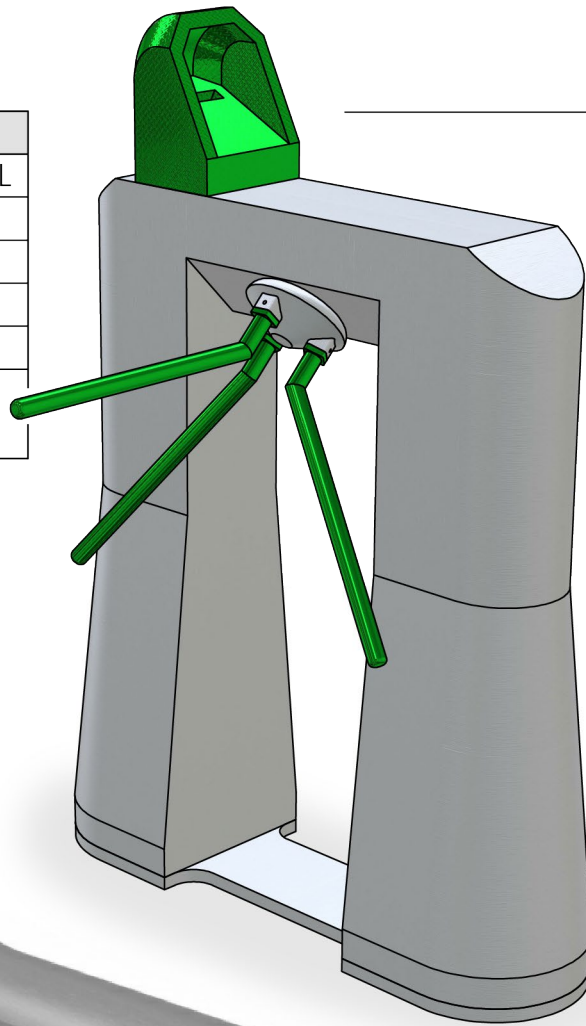

Data sheet 2 - assembled turnstile

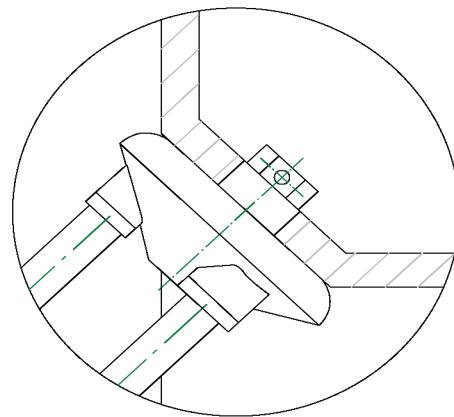
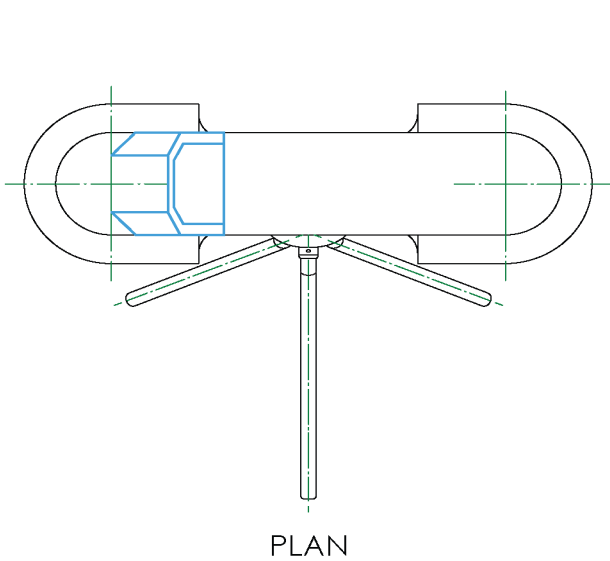

ENLARGED VIEW SHOWING ASSEMBLY FOR PART 1 AND PART 2 (NOT TO SCALE)

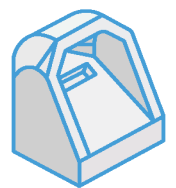
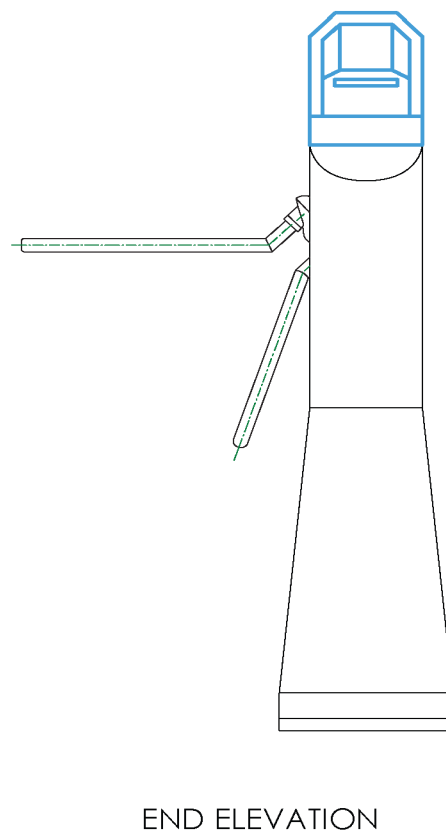
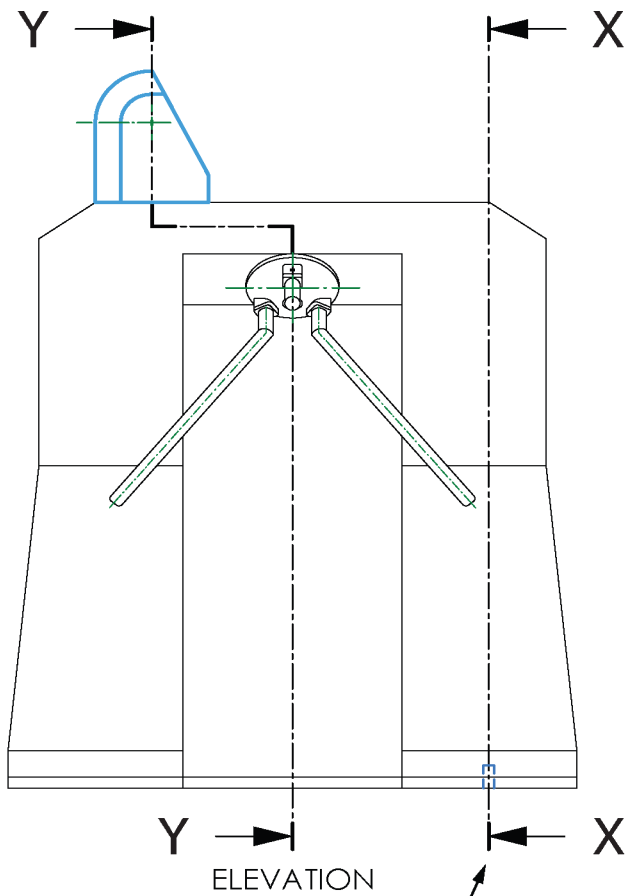

ticket scanner (part 5) provided as a step file

Cutting plane X-X positioned through the centre of hole in base component

TURNSTILE ASSEMBLY	
SOME DETAIL REMOVED TO AID CLARITY	
NOT TO SCALE	

Data sheet 3 - body (part 1)

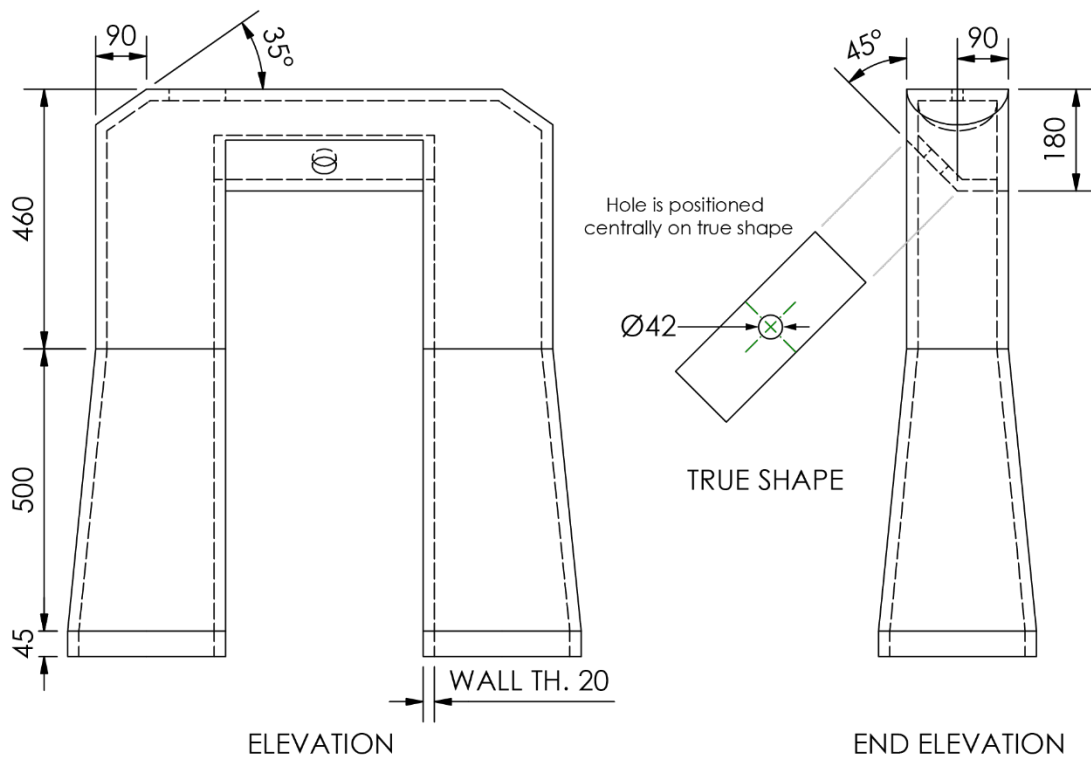
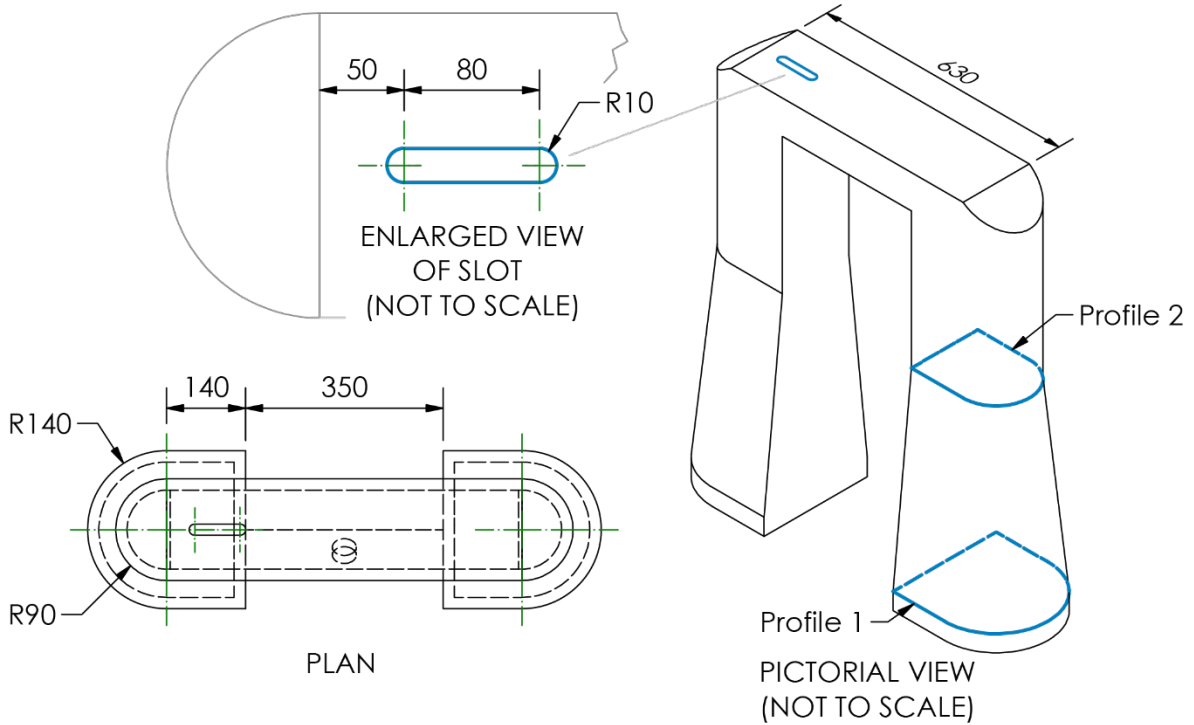

SOME DETAIL REMOVED TO AID CLARITY	NOT TO SCALE ALL SIZES IN MM	
------------------------------------	---------------------------------	--

Data sheet 4 – swivel (part 2)

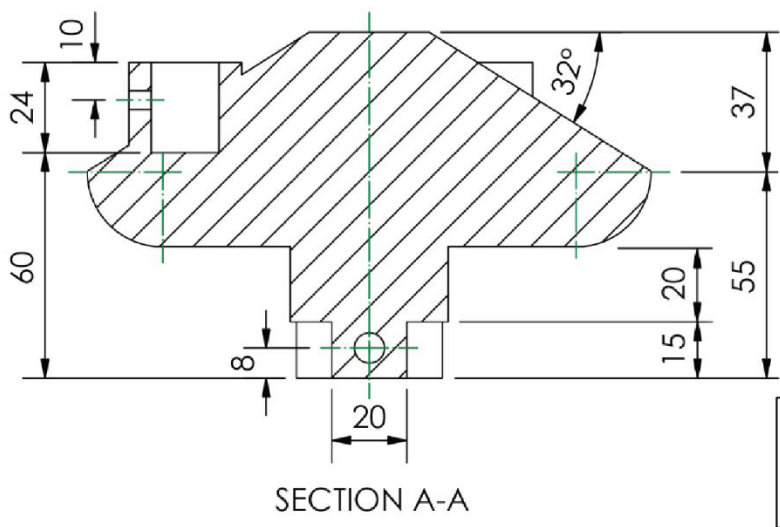
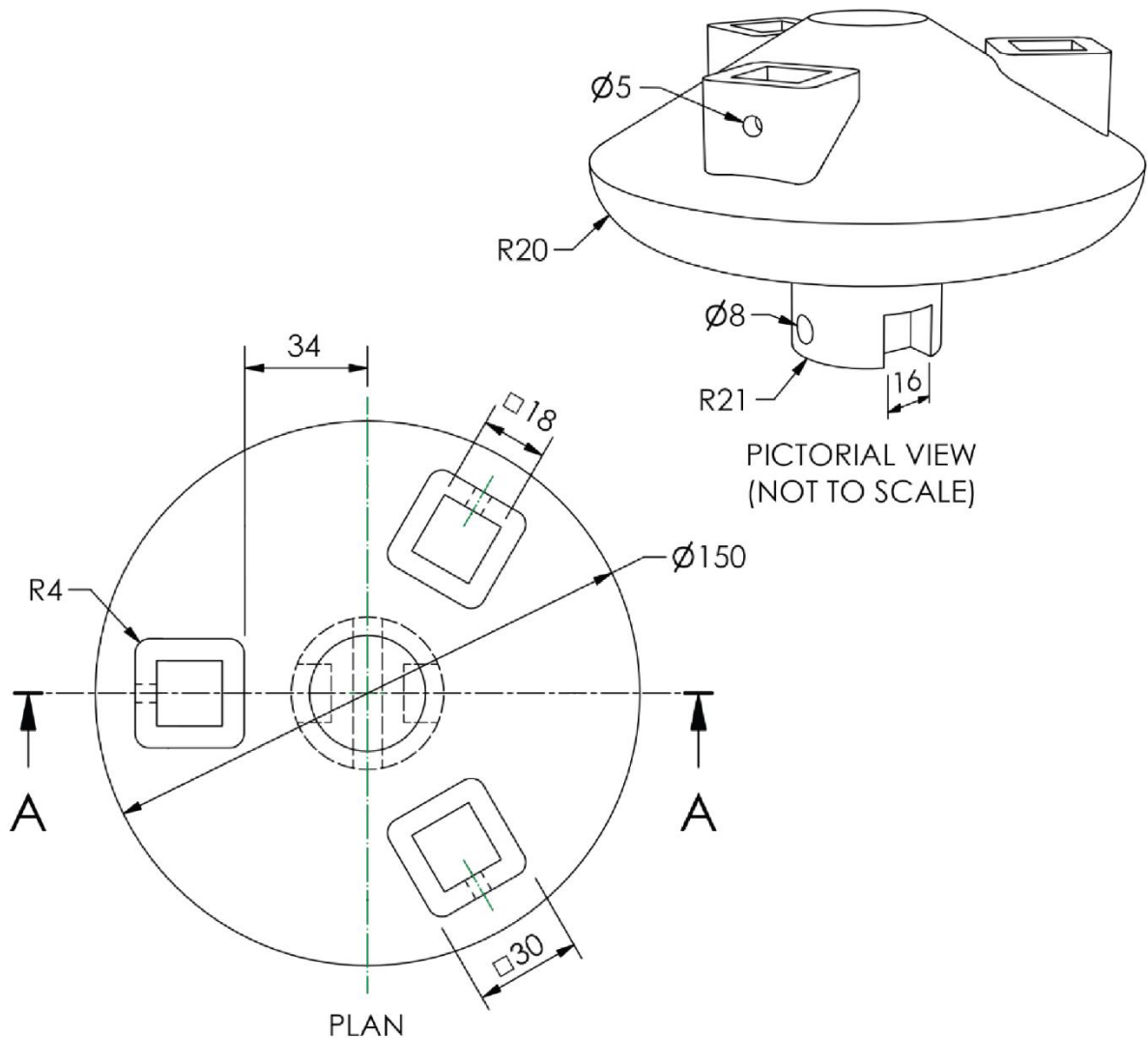

3 REPEATED FEATURES
EQUALLY SPACED
AROUND 360°

SOME DETAIL REMOVED
TO AID CLARITY

NOT TO SCALE
ALL SIZES IN MM

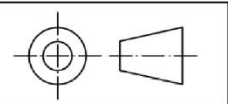

Data sheet 5 – arm (part 3)

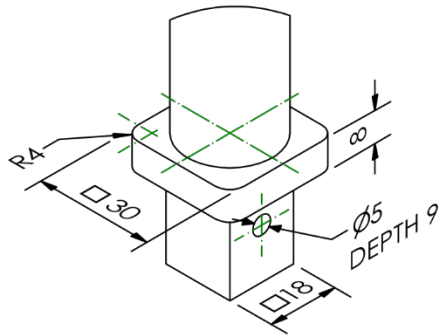

DETAIL A
(NOT TO SCALE)

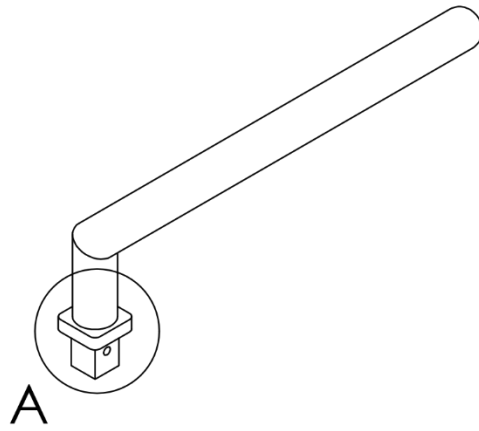

PICTORIAL VIEW
(NOT TO SCALE)

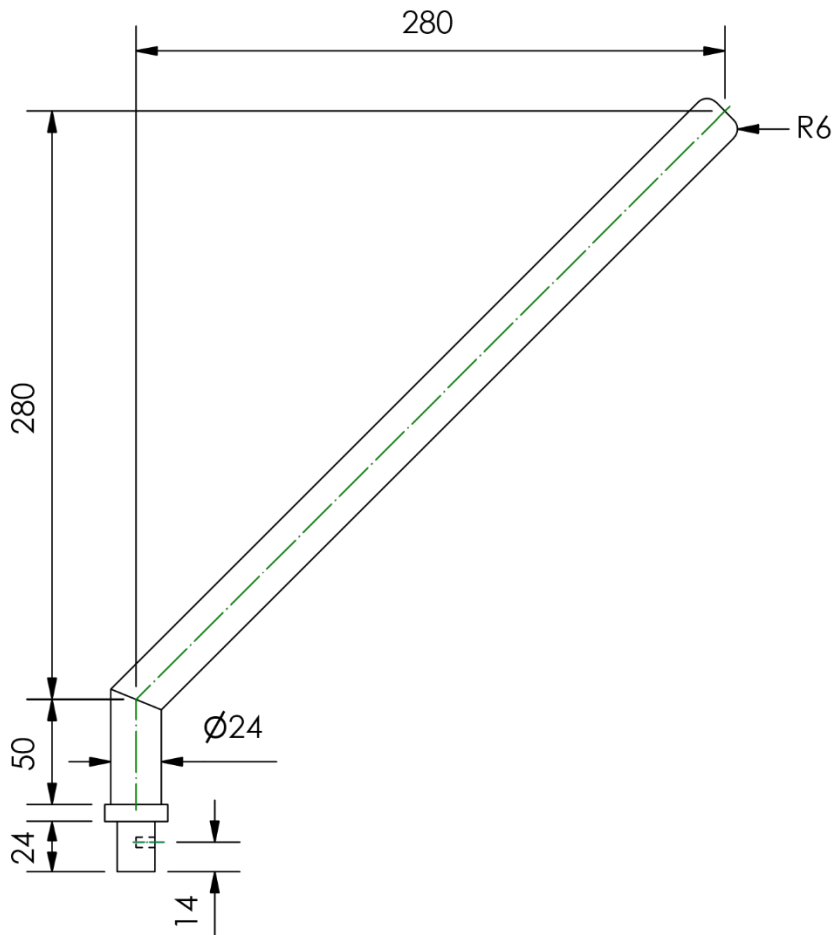

ORTHOGRAPHIC VIEW

NOT TO SCALE
ALL SIZES IN MM

Data sheet 6 – base (part 4)

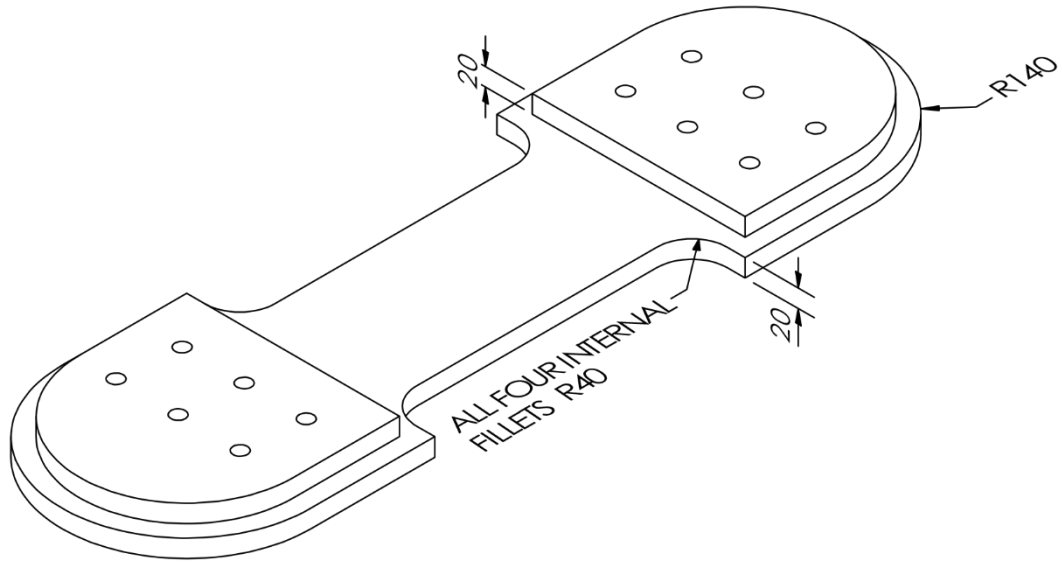

PICTORIAL VIEW
(NOT TO SCALE)

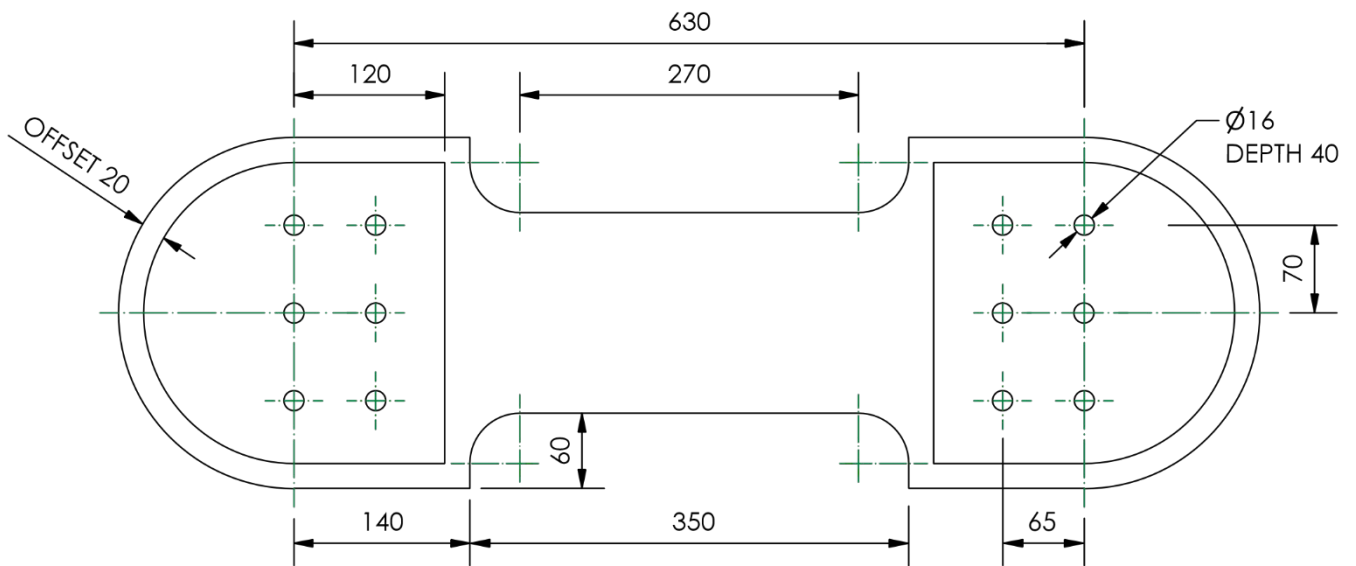

ORTHOGRAPHIC VIEW

NOT TO SCALE
ALL SIZES IN MM

Data sheet 7 – STEP files and viewpoint

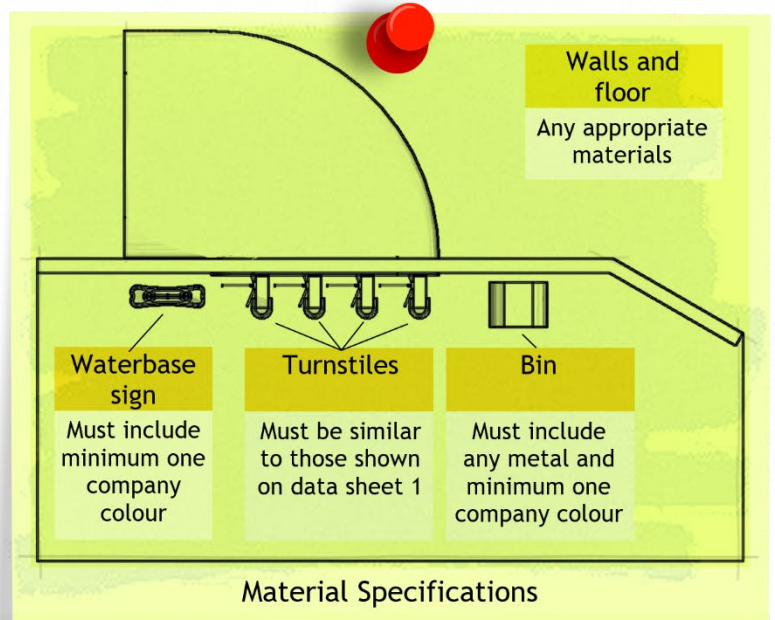
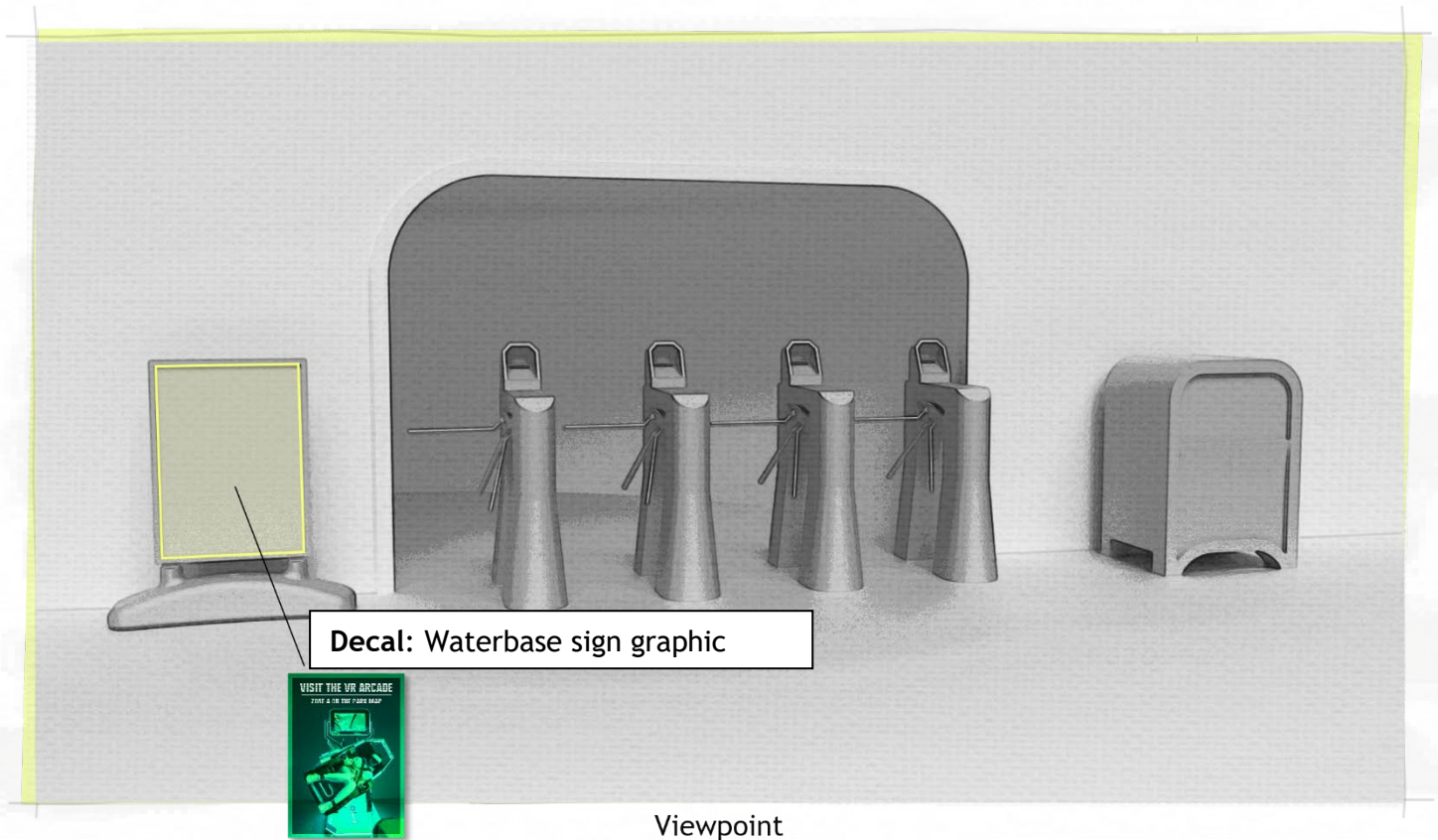

Example viewpoint is shown on representation of one single sheet of A3 paper. If an A3 printer is not available, A4 paper is acceptable. Render must be as close to the size of the paper being printed on as is possible.

When using company colours in render, the RGB values are:

Colour 1	Colour 2	Colour 3	Colour 4
R: 83	R: 227	R: 153	R: 211
G: 121	G: 241	G: 99	G: 200
B: 70	B: 220	B: 48	B: 190

Data sheet 8 - promotional poster

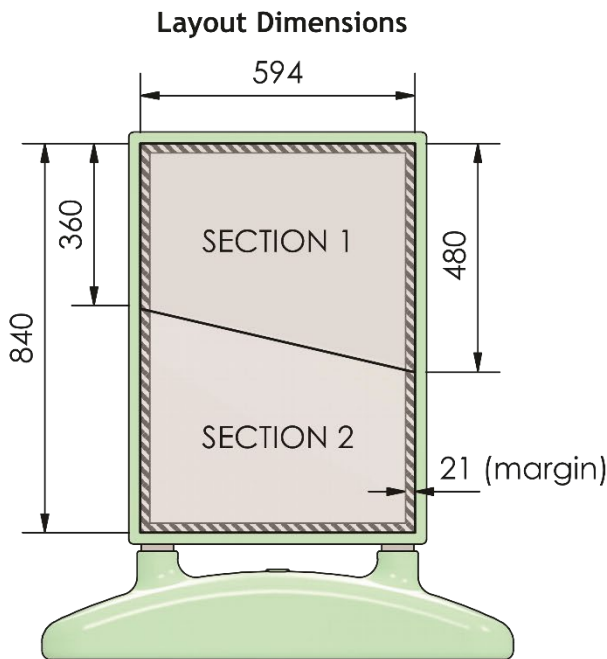

NO TEXT IS ALLOWED WITHIN THE MARGIN

Produce on a scale of 1:3

Logo options



Logo V1



Logo V2



Logo V3

Colours

Colour 1	Colour 2
C: 78 M: 33 Y: 88 K: 22	C: 16 M: 0 Y: 20 K: 0
Colour 3	Colour 4
C: 36 M: 61 Y: 96 K: 24	C: 22 M: 22 Y: 25 K: 0

Approved Fonts

Accent SF
Accord Heavy SF
 Arial
 Bahnschrift
 Century Gothic
 Toledo SF

Section 1 Copy Text

Queue-Jump Wrist Band

Avoid wait times with the Queue-Jump Wrist band. A member of staff will scan your unique barcode and issue you with a ride-time ticket. If you have access to the Cainwood App, this will automatically appear on your mobile device. Simply show up at the time you are given, and jump straight to the front of the queue!

The Cainwood App

Download the Cainwood App to gain access to a variety of features. View your queue-jump schedule and get notifications when your ride times are due. Upload funds to the app and use your wrist band barcode to pay for food, drinks and gifts. Get first-access to book into our daytime shows and choose the best seats in the house!

For more information about our privacy policy visit our website at www.cainwoodcustomer.com

Section 2 Copy Text

The Dino Park

- Over eighty rides and attractions
- Scotland's fastest roller coaster
- Two new VR arcades
- A variety of live shows
- Twelve dine-in restaurants
- Three soft play facilities
- High speed Wi-Fi throughout the park
- Dino-carts available for rent

Winter Offer

30% off weekday tickets if you pre-book online by 31st October. The winter season runs from 15th November until 21st January. This offer excludes bank holidays and all weekends.

Data sheet 9 - image bank



Dinosaur1



Dinosaur2



Dinosaur3



Forest1

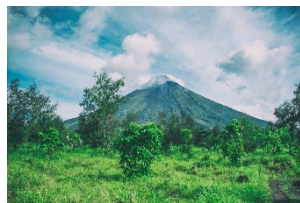

Forest2



Forest3



Ground Texture



LogoV1



LogoV2



Logo V3



Mobile Phone



Dinosaur themed graphics



Queue-Jump Wrist band



Restaurant



Roller Coaster1



Roller Coaster2



VR1



VR2

Data sheet 10 - queue-jump wristband

Note: Plan view should be symmetrical horizontally and vertically

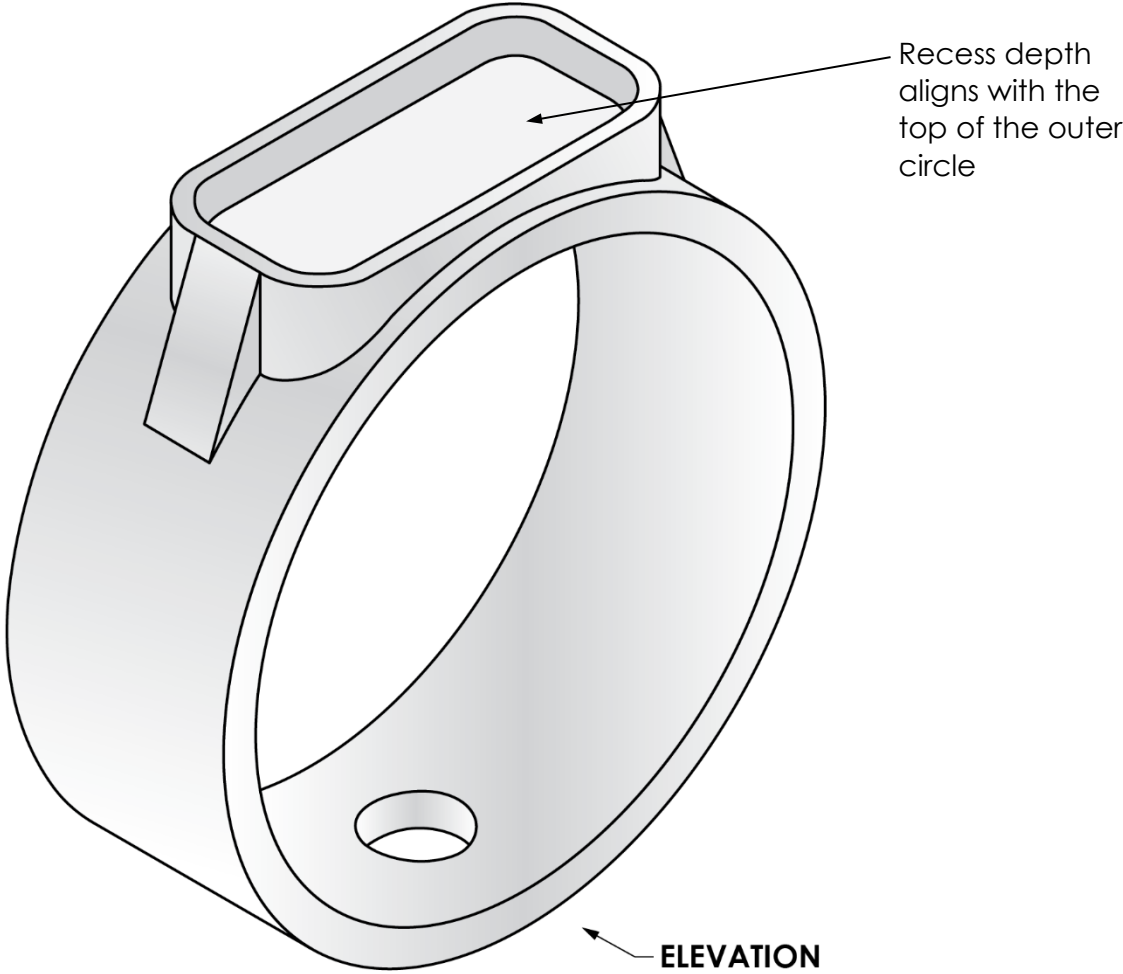

Copyright acknowledgements

Data sheets 7 and 9: various images – Creative Commons CC0 and sourced www.pexels.com

Administrative information

Published: January 2025 (version 1.0)

History of changes

Version	Description of change	Date
1.1	Data sheet 4 - hidden detail line removed from the plan for clarification.	15/1/25

Note: you are advised to check SQA's website to ensure you are using the most up-to-date version of this document.

Security and confidentiality

This document can be used by SQA approved centres for the assessment of National Courses and not for any other purpose.

This document may only be downloaded from SQA's designated secure website by authorised personnel.

© Scottish Qualifications Authority 2025