



National
Qualifications
2025

2025 Graphic Communication

Higher

Question Paper Finalised Marking Instructions

© Scottish Qualifications Authority 2025

These marking instructions have been prepared by examination teams for use by SQA appointed markers when marking external course assessments.

The information in this document may be reproduced in support of SQA qualifications only on a non-commercial basis. If it is reproduced, SQA must be clearly acknowledged as the source. If it is to be reproduced for any other purpose, written permission must be obtained from permissions@sqa.org.uk.



General marking principles for Higher Graphic Communication

Always apply these general principles. Use them in conjunction with the specific marking instructions, which identify the key features required in candidates' responses.

- (a) Always use positive marking. This means candidates accumulate marks for the demonstration of relevant skills, knowledge and understanding; marks are not deducted for errors or omissions.
- (b) If a candidate response does not seem to be covered by either the principles or detailed marking instructions, and you are uncertain how to assess it, you must seek guidance from your team leader.
- (c) For 'Describe' questions
Candidates must provide a statement or structure of characteristics and/or features, not just an outline or a list. For example, they can refer to a concept, experiment, situation, or facts in the context of and appropriate to the question. The number of marks available for a question indicates the number of factual/appropriate points required.
- (d) For 'Explain' questions
Candidates must relate cause and effect and/or define relationships. This must be in the context of the question, or a specific area within the question.
- (e) For 'Compare' questions
Candidates must demonstrate knowledge and understanding of the similarities and/or differences between things, methods, or choices. This must be in the context of the question, or a specific area within the question.
- (f) Candidates can respond to any question using text, sketching, annotations, or combinations of these. Award marks for the information conveyed. Do not award marks for the quality of sketching.

Marking instructions for each question

Question		Expected response	Max mark	Additional guidance
1.	(a)	<p>Describe Transparency</p> <ul style="list-style-type: none"> transparent box with white colour fill on page 3 paw prints on FAQs on page 4 paw print stamp on “Chewy’s photoshoot” on page 4 	2	There is no evidence to suggest pawprints in the background have transparency applied so these cannot be accepted.
	(b)	<p>Describe Rhythm</p> <ul style="list-style-type: none"> repetition of pattern of paw prints across background of pages 2 <i>or</i> 3 repetition of white paw prints in orange band across the top of pages 3, 4 & 5 repetition of pawprints in bottom left/right hand corners of pages alternating blue and orange colour fills in the FAQ section repetition of pawprints with Q and A in the FAQ section repetition of formatting of orange headline repetition of formatting of orange subheadings repetition of blue outline with drop shadow on three images on page 2 repetition of orange outline on three images on page 5 	2	
	(c)	<p>Describe Grid Structure</p> <ul style="list-style-type: none"> vertical columns created within document three images vertically aligned within column of text on page 5 all images on page 5 align with the column/grid structure consistent column structure creates formal layout layout/organisation/formatting of Q&A section in rows 	2	

Question		Expected response	Max mark	Additional guidance
1.	(d)	<p>Explain Proportion</p> <ul style="list-style-type: none"> the blue heart is large compared with other images on the page which leads the readers eye towards the available dogs solid colour fill on page 2 which draws attention to the title of the layout on pages 2 or 5 three of the images are the same size meaning none stand out reference to enlarged text (such as 'Dogs leave paw prints on our hearts') which draws attention to text page 2&3, paw print images increase and decrease in size which draws reader's eye across the layout image of dog in front of the wall on page 3 takes up proportionately more space than text which draws attention to the image image of "Chewy's photoshoot" on page 4 takes up proportionately more space than text which draws attention to the image 	1	

Question		Expected response	Max mark	Additional guidance
1.	(e)	<p>Explain Emphasis</p> <ul style="list-style-type: none"> • reverse applied to text helps bring emphasis to captions • lines above and below frame the pull quote on page 5 which attracts the reader’s eye • pull quote is bold text which makes it stand out • orange colour fill on page 2 behind website helps to separate the information and make it stand out from the rest • white outline on headings makes them stand out compared to other text • contrasting colour fills on FAQs make the section stand out • drop shadows on headings, blue heart and horizontal images with blue outlines create depth helping them to stand out on the page • blue outlines on dog images on page 2 which draws attention to them • orange outlines on dog images on pages 3, 4 and 5 which draws attention to them 	1	
	(f)	<p>Describe Unity</p> <ul style="list-style-type: none"> • repeated use of colour orange <i>or</i> repeated use of colour blue • headings and subheadings use the same font throughout the document • the subheading “available dogs” is blue and links to the images and colour fill above • repetition of reverse text in captions • repeated use of sans serif typeface for body text • repetition of the italic Qs & As in the FAQ section • repeated use of shape 	2	<p>Response must make reference to the relationship between two or more elements that create unity.</p> <p>Candidates must be specific about the use of orange and blue.</p> <p>Accept responses that refer to an orange and blue colour palette</p>
	(g)	<ul style="list-style-type: none"> (i) registration mark (ii) pull quote (iii) column rule (iv) folio (v) crop marks 	5	(iv) also accept reverse or bleed

Question			Expected response	Max mark	Additional guidance
1.	(h)		<ul style="list-style-type: none"> • ability to quickly make changes/ iterations of a layout • availability of actual images • placeholder text can be used • wider range of colours • digital tools like snap/snap to grid/guidelines/snap to guidelines can support creation of layout • use of layers can speed up editing 	2	

Question		Expected response	Max mark	Additional guidance
2.	(a)	<p>Figure 1 - Promotional Graphic</p> <ul style="list-style-type: none"> • promotion or advertising for the cabin • give an indication to the viewer of the aesthetics/size/layout of the cabin. <p>Figure 2 - Production Graphic</p> <ul style="list-style-type: none"> • technical details which allow construction of the building • indicate the location of fixed windows (etc) to the construction trade. <p>Figure 3 - Preliminary Graphic</p> <ul style="list-style-type: none"> • used to communicate the design proposal 	3	<p>Must include the relevant 3P and relate to the cabin and not generic features of a promotional item.</p> <p>Must include the relevant 3P and mention the cabin and not a generic product.</p> <p>Must include the relevant 3P. May reference communicating colour, style, size, or other relevant aesthetic features of the cabin and not a generic product.</p>
	(b)	<ul style="list-style-type: none"> • to show the object in a realistic setting • gives an indication of scale • different conditions can be shown ie light, dark, weather etc • shows how the object would fit into its surroundings 	2	
	(c)	Window sliding horizontally	1	
	(d)	<p>Application of:</p> <ul style="list-style-type: none"> • light • shadow • materials • texture 	2	Do not accept one word responses.
	(e)	<ul style="list-style-type: none"> • allows for scalability without pixelation/loss of quality • smaller file size • can be edited without the use of specialist photo editing software 	2	
	(f)	3	1	
	(g)	<ul style="list-style-type: none"> • the size of the paper • the size of the site boundary • the amount of detail to be displayed 	2	

Question		Expected response	Max mark	Additional guidance
3.	(a)	Radial Array	1	
	(b)	Pitch Circle Diameter	1	
	(c)	<ul style="list-style-type: none"> • components are modelled individually • they can be inserted into an assembly to assemble using constraints • any changes to a component will need to be done by editing it individually 	2	
	(d)	intersect	1	
	(e)	<ul style="list-style-type: none"> • 3D models can be used to directly manufacture (CNC/CAM) • to enable dimensions to be extracted from the CAD model, without production drawings • 3D models can be used to show how complex items are assembled • 3D models do not need a manufacturer to interpret complex production drawings • production drawings can be created and fully dimensioned from the CAD model • allows for a range of tests/ simulations to be undertaken prior to manufacture. 	2	<p>Any two points.</p> <p>Do not accept 'for manufacture', without reference to CNC or CAM technologies such as 3D printing.</p> <p>Candidates must justify the purpose of the drawing eg dimensions, tolerances, materials, surface finish.</p> <p>Generic 'test the model' should not be accepted. Generic 'simulate a situation' should not be accepted.</p>
	(f)	<ul style="list-style-type: none"> • correctly identify where to trim • mirror on horizontal line • offset of 2mm 	3	
	(g)	<ul style="list-style-type: none"> • centre axis all the components • mate hand 1 to the flat face of the shaft • offset hand 1 and hand 2 by 2mm • orientate hand 2 by 90 degrees 	4	

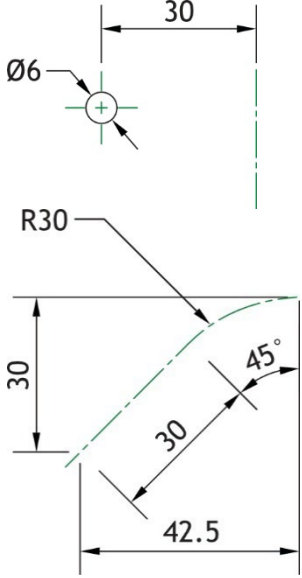
Question		Expected response	Max mark	Additional guidance
4.	(a)	<ul style="list-style-type: none"> the sketches could include realistic material representations they can be built up in a series of layers to ease editing they are stored electronically and do not require scanning using hardware able to show clients changes instantly software tools for ease of editing eg colour, material, undo etc sketches can be exported to other packages easy to share through email more sketching tools available, such as brushes and colours 	2	<p>Do not accept generic 'quicker or easy to change' descriptions, must give an example such as layers can be used or turned on or off etc.</p> <p>Candidates must mention a method of sharing.</p>
	(b)	<ul style="list-style-type: none"> centre of dia 6 profile, 30 distance from centre axis (1 mark) helix command (1 mark) revolutions 12, pitch 10, length 120 (any two of three) (1 mark) dia 6 profile for next step (1 mark) correct path on perpendicular workplane with all dimensions (1 mark) extrude/sweep along a path command (1 mark) 	6	 <p>Candidate could project geometry/infer from a sketch</p>
	(c)	<ul style="list-style-type: none"> ellipse (280 x 180) extruded 10 (1 mark) offset workplane 105 (1 mark) dia 130 circle distanced 85 from back edge of ellipse (1 mark) loft command (1 mark) r52 (dia 104) circle with correct location (121 from centre of dia 130 circle and workplane) with correct extrusion (1 mark) dia 88 in correct location and extrude subtract with sufficient distance (1 mark) dia 6 circle, including correct location (30, 26) and extrude subtract 30 (1 mark) 	7	<p>Accept "extrude to next surface" with circle location. Extrusion must be at least 62.3mm if specifying extrusion length.</p>

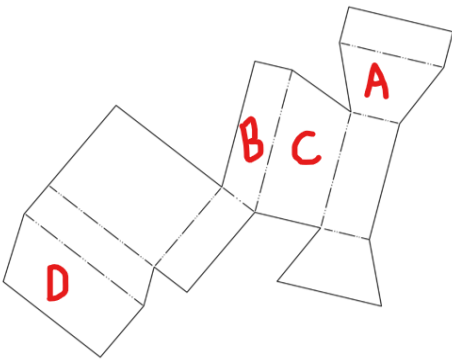
Question		Expected response	Max mark	Additional guidance	
4.	(d)	<ul style="list-style-type: none"> shell with wall thickness 10 (1 mark) remove bottom face (1 mark) 	2		
	(e)		4		
	(f)	(i)	bottom left	1	
		(ii)	top left	1	
	(g)	<ul style="list-style-type: none"> files can be accessed remotely from anywhere in the world which allows for remote working files can be easily shared between coworkers which allows for collaboration files can be encrypted which ensures file protection file restoration features (old versions/back-ups) which prevent loss of work files are not device dependent which means they can be accessed from any device 	2		
	(h)	<p>Describe Contrast</p> <ul style="list-style-type: none"> red border contrasts with green background red T/E/W contrasts with green background bold T/E/W contrasts with regular text straight line contrast with zig-zag line script font contrasts with sans serif font textured paper behind logo <i>or</i> textured image of pencils contrasts with solid colour fill diagonal pencil in logo contrasts with image of photo any instance of any two contrasting shapes 	2	Reverse does not create contrast.	

Question		Expected response	Max mark	Additional guidance
4.	(i)	<ul style="list-style-type: none"> • text and images can be edited separately • layers can be turned off and on to improve clarity during the production of the layout • the layers can provide a master page for similar future layouts that may be required • layers can be edited without affecting other elements of the layout • layers can be ordered by either moving backwards or forwards • layers can be locked to prevent them from being edited or moved by mistake 	3	
	(j)	<ul style="list-style-type: none"> • can view embedded content (movie clip) in order to interact with it • easy to zoom in or increase size of font to improve accessibility • can expand areas of text to 'read more' allowing more information to be included • can view linked material (social media platforms) allowing better user engagement • can be translated into other languages which allows the consumer to read in their chosen language • built in accessibility features, such as text to speech, allows more people to access content • can be read in different lighting conditions, such as in the dark, with justification e.g. device can be backlit, brightness level can be adjusted 	3	<p>Candidates must have three valid explanations (cause and effect).</p> <p>Must be a benefit to the consumer of reading online.</p> <p>Do not accept environmental considerations.</p>

Question		Expected response	Max mark	Additional guidance
5.	(a)		5	<ul style="list-style-type: none"> ◆ areas correctly hatched (1 mark) ★ areas correctly hatched (1 mark) ■ areas correctly hatched (1 mark) ● areas correctly hatched (1 mark) ◆ Webs, fixing nut and bolt not hatched (1 mark)
	(b)	<ul style="list-style-type: none"> • part section • revolved section • stepped section 	2	Accept: <ul style="list-style-type: none"> • removed section • half section • local section

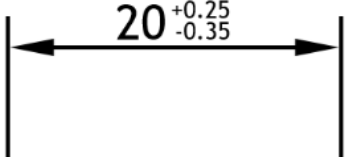
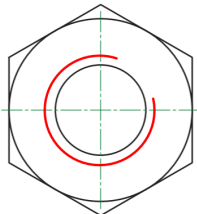
Question			Expected response	Max mark	Additional guidance
5.	(c)	(i)		2	1 mark for format 1 mark for correct numbers Do not accept Common Tolerance. Unit of measurement should not be included. <i>Size of written text is not relevant</i>
		(ii)	<ul style="list-style-type: none"> a maximum and minimum size that will allow the product to assemble or work correctly 	1	
	(d)		 <p>ELEVATION</p>	1	
	(e)	(i)	$90 - 15 = 75$	1	Sum not required
		(ii)	$90 + 30 = 120$	1	Sum not required

[END OF MARKING INSTRUCTIONS]