

FOR OFFICIAL USE



--	--	--	--	--	--

National
Qualifications
2025

Mark

--

X835/76/01

Graphic Communication

WEDNESDAY, 30 APRIL

1:00 PM – 3:30 PM



* X 8 3 5 7 6 0 1 *

Fill in these boxes and read what is printed below.

Full name of centre

--

Town

--

Forename(s)

--

Surname

--

Number of seat

--

Date of birth

Day

--	--

Month

--	--

Year

--	--

Scottish candidate number

--	--	--	--	--	--	--	--	--	--

Total marks — 90

Attempt ALL questions.

You may use a calculator.

All dimensions are in mm.

All technical sketches and drawings use third angle projection.

You may use rulers, compasses or trammels for measuring.

In all questions you may use sketches and annotations to support your answer if you wish.

Write your answers clearly in the spaces provided in this booklet. Additional space for answers is provided at the end of this booklet. If you use this space you must clearly identify the question number you are attempting.

Use **blue** or **black** ink.

Before leaving the examination room you must give this booklet to the Invigilator; if you do not, you may lose all the marks for this paper.



* X 8 3 5 7 6 0 1 0 1 *

Total marks — 90
Attempt ALL questions

For questions 1 (a) to (f), refer to the supplementary sheets provided.
A series of double-page spreads have been created to promote a dog rescue centre.

1. (a) Describe, giving **two** examples, how the graphic designer has used transparency to enhance the layouts.

2

- (b) Describe, giving **two** examples, how the graphic designer has created rhythm to enhance the layouts.

2

- (c) Describe, giving **two** examples, how the graphic designer's use of grid structure has enhanced the layouts.

2



* X 8 3 5 7 6 0 1 0 2 *

1. (continued)

(d) Explain, giving **one** example, why the graphic designer's use of proportion has enhanced the layouts.

1

(e) Explain, giving **one** example, why the graphic designer's use of emphasis has enhanced the layouts.

1

(f) Describe, giving **two** examples, how the graphic designer's use of unity has enhanced the layouts.

2

[Turn over



1. (continued)

(i) **Success Story**

Cassi and Poppy
 Dolom qui quam quis nonsequiaepe seque landis dipsametum seruptatias aut quo corest liquid ut vende ipsandel ma suntiae dolorest, officatem rempor alitem rem invelic aborior ehendit invelit aut ut quam quam, utes rehendit est occabo. Nem nihil enitatissi que ex eatas aut voluptae parcitati odiam dolorro rereheniet, sanisqu osunt latatia consequid quam, ut quiaie exeriac voluptasimi, occat. Ehendip istiamenda vollorissi odit, eaquias idunt et vel etum repro consequat estis dolupid mint lamet dolore, opta seque la dust exceptuad. Ectatus pre nobitio nsectione parumquidid

Ximil iunto molum et dendel molorat isimusdaera dolesed et eicipit aspit am dolom et acea dolore volo magni accus aut quo es dolori blanim arunt dolorum suntibere posse commiendae volutem. Int, apisto beatem quam fugiat pore volendebit fugiati onseriti nit audis esequo iusam quo ipsapiet, sunt. Abo. Nam, od est quaepest od est lacea ru ntemporit opta velit, optaqui ommodi volor sintem rese dipsapid eictat.

"Cassi and Poppy were living on the streets. Now they are in a loving home."

Natureh entinti veribusam quaerume sitatem aut re ressi cusaped quiatem quiducillit exerferum ipicatem quamus, nimpore preperestis voluptias incti none lantent exeritibus doloriam labo. Uciis qui dionsequodis estent, te sunt. Aqui cor aut ommo quosa vellam doluptatur re.

Ihil imenimolene porempos et quae non porepelitas eum laboren dentini tinumqu iatur, ime ilita voluptae. Ovid que con re volor am volorepre lab is quis es dendis as et reses restem non provide

Ait ma sint ut aped minctem et facessum rerciliquam sedisquate excepernat escipiet et velitibusam faccae nobit omnit omnis dolorem harum quate et plabore core vendit, con non perere comminust, solorest diaest, coreper sperum lit ommod molTorias maxim aute autecust fuga. Ga. Nam sime nim agnisquibus dipsa sint ero te et, est fogias qui omnimus dolesedis aligent quo id quatis ut quis aut omnimaximus, sunt accupatquam qui duntintius eius velenimus, sandio eum aute nest as ant.

Nimaxim in eatecatur, oditia cust, volore nis quod eos ipsam alicta con et fugit ea ducimus numqui dis dunt, si omniscis et atur se ea dem reicae iusapitiis accae necea nem quater rem quiam reptatur magnim sinvenimusae re prem id modis sed quatet quid mi, volupta idelia est, nulluptatum consequuist lacepud itatusda vololibus sum hil esed qui destis nonsed

liassitatem que omnis mos apellabo. Itatque sim inctur si doluptate et, quundem simpor maio. Nam, occustrum lautatis elis anient vellab illuptatur, as mo iliaerspis dolorest imintiundis es precaboreri blam, conecus danditatures entin receperum sa consent es santis quam, et dolecu met omnihil landignis sit eumque voloreseque volutem poriame commo quo enissime ducil invellabo. Volorem qui doluptatem.

Dam inci incimin ctatio volupta comminus ese velles volesto eium int repe porapelest duci aut eniscium faciene pores quam reium, quasidum argunapos ipsam.

(ii)

(iii)

(iv)

(v)

(g) State the name of the DTP terms and techniques labelled on the image above.

5

- (i) _____
- (ii) _____
- (iii) _____
- (iv) _____
- (v) _____



1. (continued)

Digital thumbnails were created before the graphic designer started to work on the final layout.

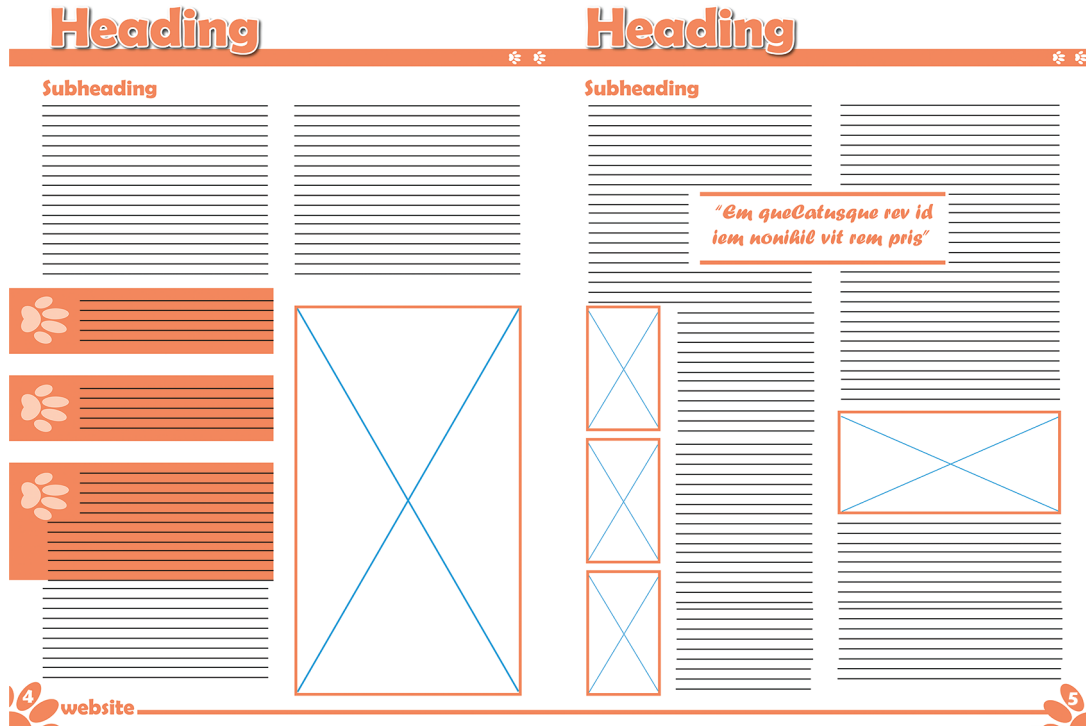

(h) Describe, giving **two** reasons, the benefits of creating digital thumbnails to the graphic designer.

2

[Turn over



2. A design company created the log cabin holiday park graphics shown below. These graphics were submitted during the planning process.



Figure 1

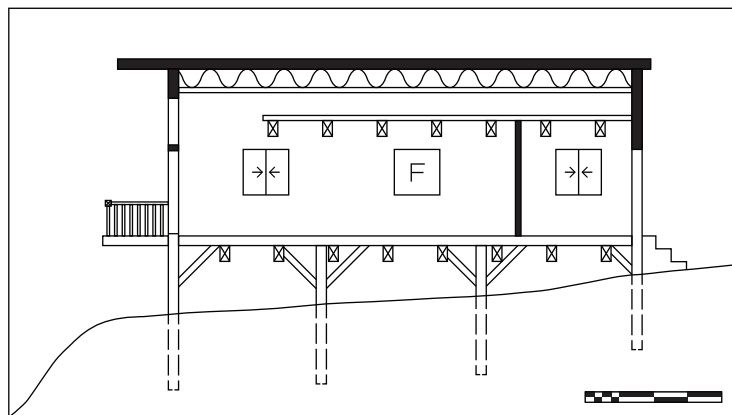

Figure 2

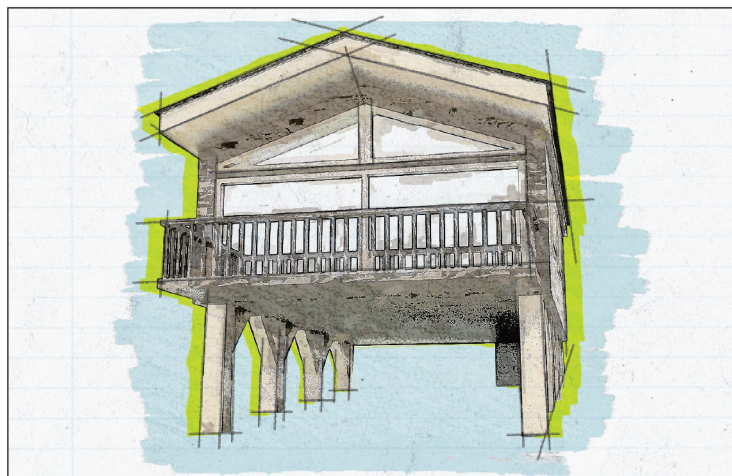

Figure 3



2. (continued)

- (a) Describe, with reference to preliminary, production and promotional graphics, the purpose of Figures 1, 2 and 3.

3

Figure 1

Figure 2

Figure 3

The designer produced the 3D CAD illustration shown in Figure 1 using a sited environment.

- (b) Describe, giving two reasons, the purpose of a sited environment.

2

[Turn over



2. (continued)

A range of British Standard symbols are used in building and construction drawings. One of the symbols is shown below.

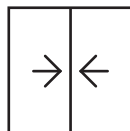

symbol A

(c) State the name of symbol A.

1

An early draft of the 3D CAD illustration is shown below in **Graphics 1 and 2**.



Graphic 1



Graphic 2

(d) Describe **two** illustration/3D rendering techniques applied to produce the realistic looking graphic shown in **Graphic 2**.

2



* X 8 3 5 7 6 0 1 0 8 *

2. (continued)



The company logo was exported in both a vector and raster graphic format.

(e) Describe **two** advantages of using a vector format for the logo.

2

[Turn over



2. (continued)

To improve the environmental impact of the holiday park several trees were added.

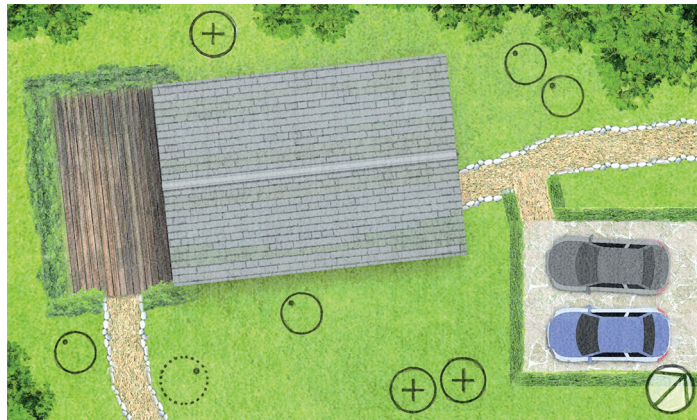

- (f) State the number of trees to be added around the log cabin. 1

Site Plans can be shown at a scale of 1:250 or 1:500.

- (g) Describe **two** factors that influence the choice of scale in this type of drawing. 2



3. A clock has been 3D modelled using CAD software.

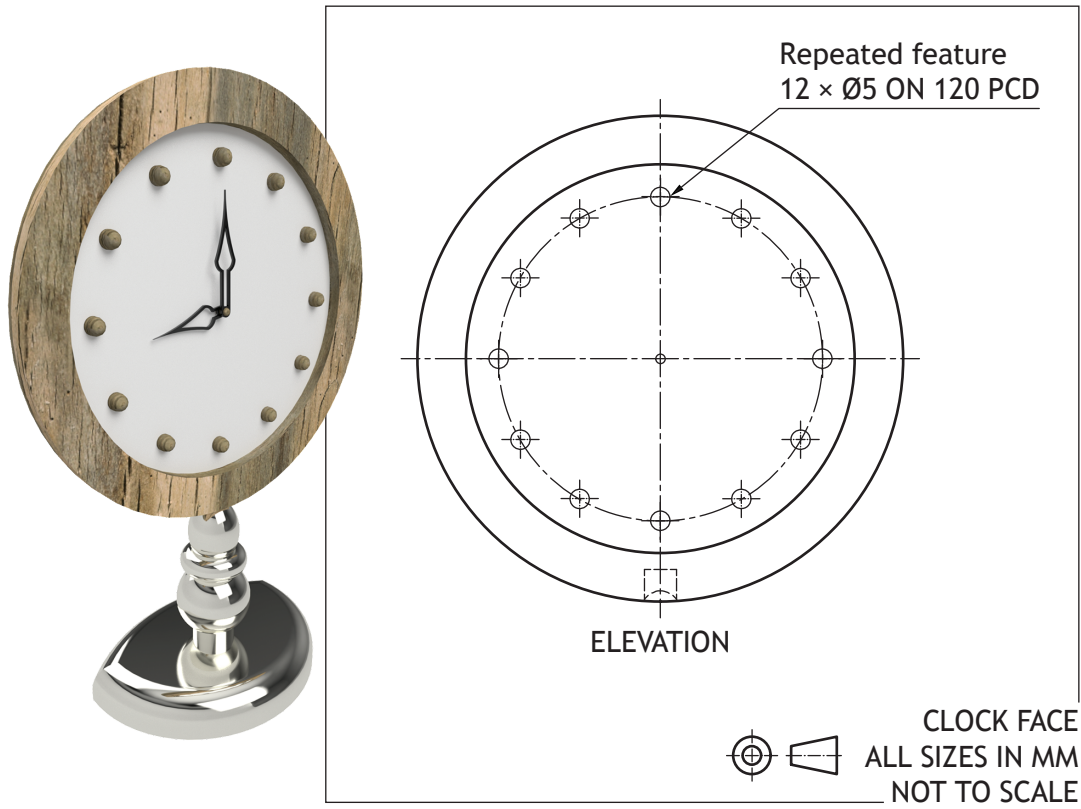

(a) State the command used to produce the repeated feature shown in the elevation. 1

(b) State what PCD stands for in the drawing above. 1

Bottom-up modelling was used to create the components of the clock.

(c) Describe the process of bottom-up modelling. 2



3. (continued)

The clock base component was created using 3D CAD modelling software. The initial steps in the modelling process are shown below.

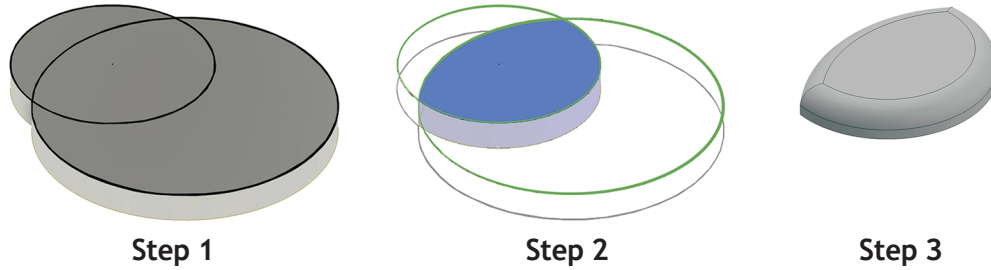

(d) State the name of the modelling edit used between Step 1 and Step 2.

1

(e) Describe, giving **two** examples, the benefits of using 3D CAD models in manufacturing.

2



3. (continued)

Two stages of the clock hand modelling process are shown below.

(f) Describe the 2D CAD techniques used to arrive from Stage 1 to Stage 2.

You may use sketches to illustrate your answer.

You may annotate the graphics below.

3

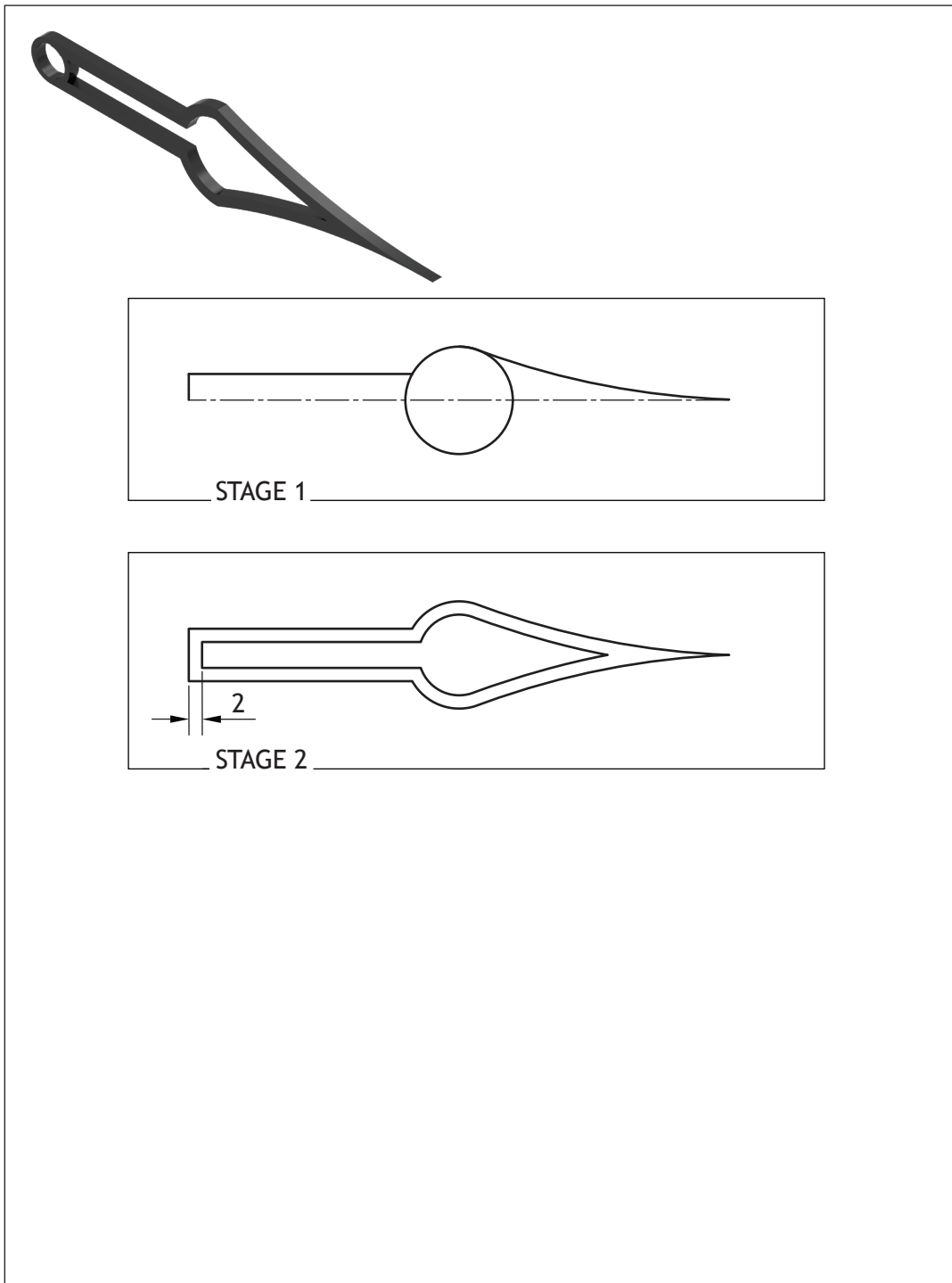

3. (continued)

A concept design for the clock hands sub-assembly is produced. The two hands shown have been constrained to the shaft using 3D CAD modelling software.

DO NOT
WRITE IN
THIS
MARGIN

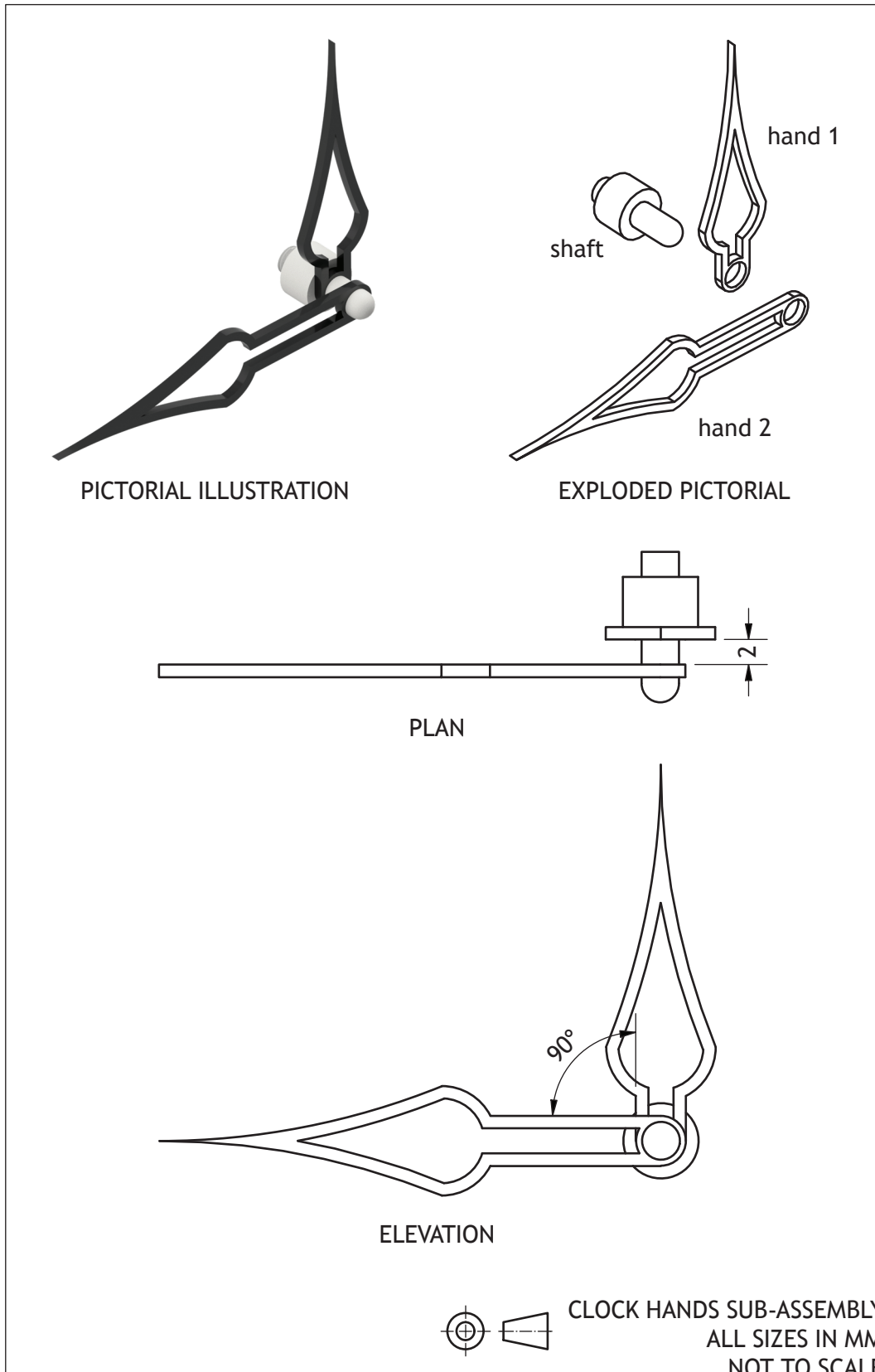

3. (continued)

- (g) Describe the steps required to constrain the hands and the shaft to each other. You may annotate **Figure 1** to help with your answer.

4

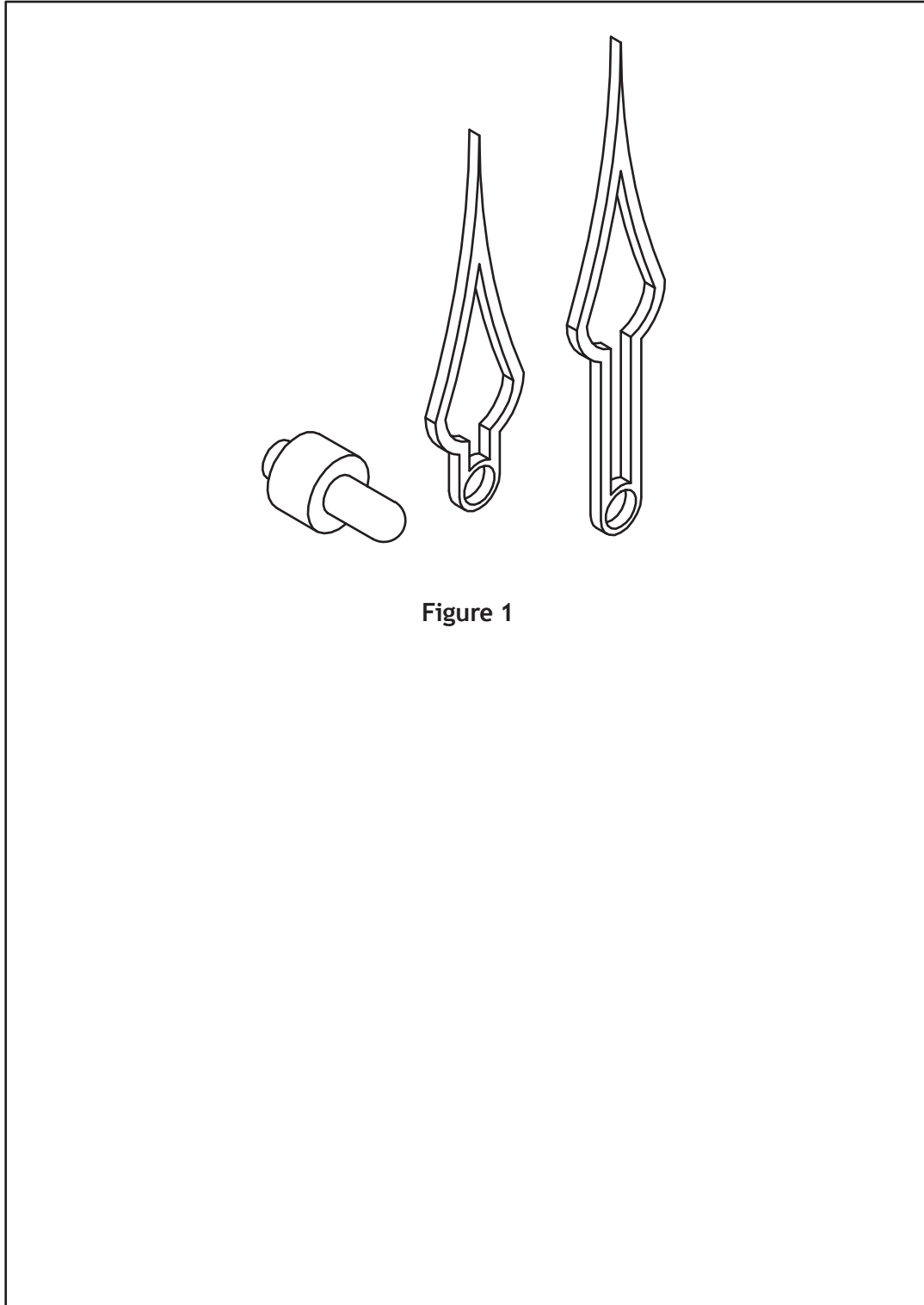
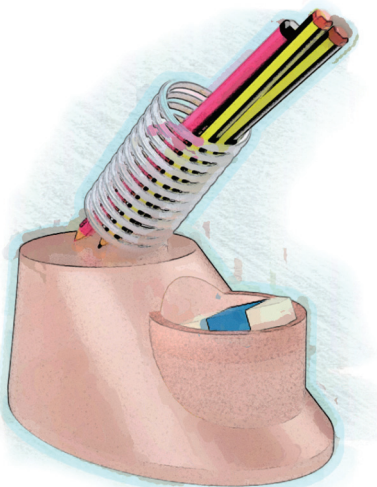

Figure 1

4. A concept for a stationery holder was generated using digital sketching.



(a) Describe **two** advantages of using digital sketching to produce graphic items. **2**



[Turn over for next question

DO NOT WRITE ON THIS PAGE



* X 8 3 5 7 6 0 1 1 7 *

4. (continued)

A CAD technician created 3D CAD components for the stationery holder. The drawing for the stationery holder top component is shown below.

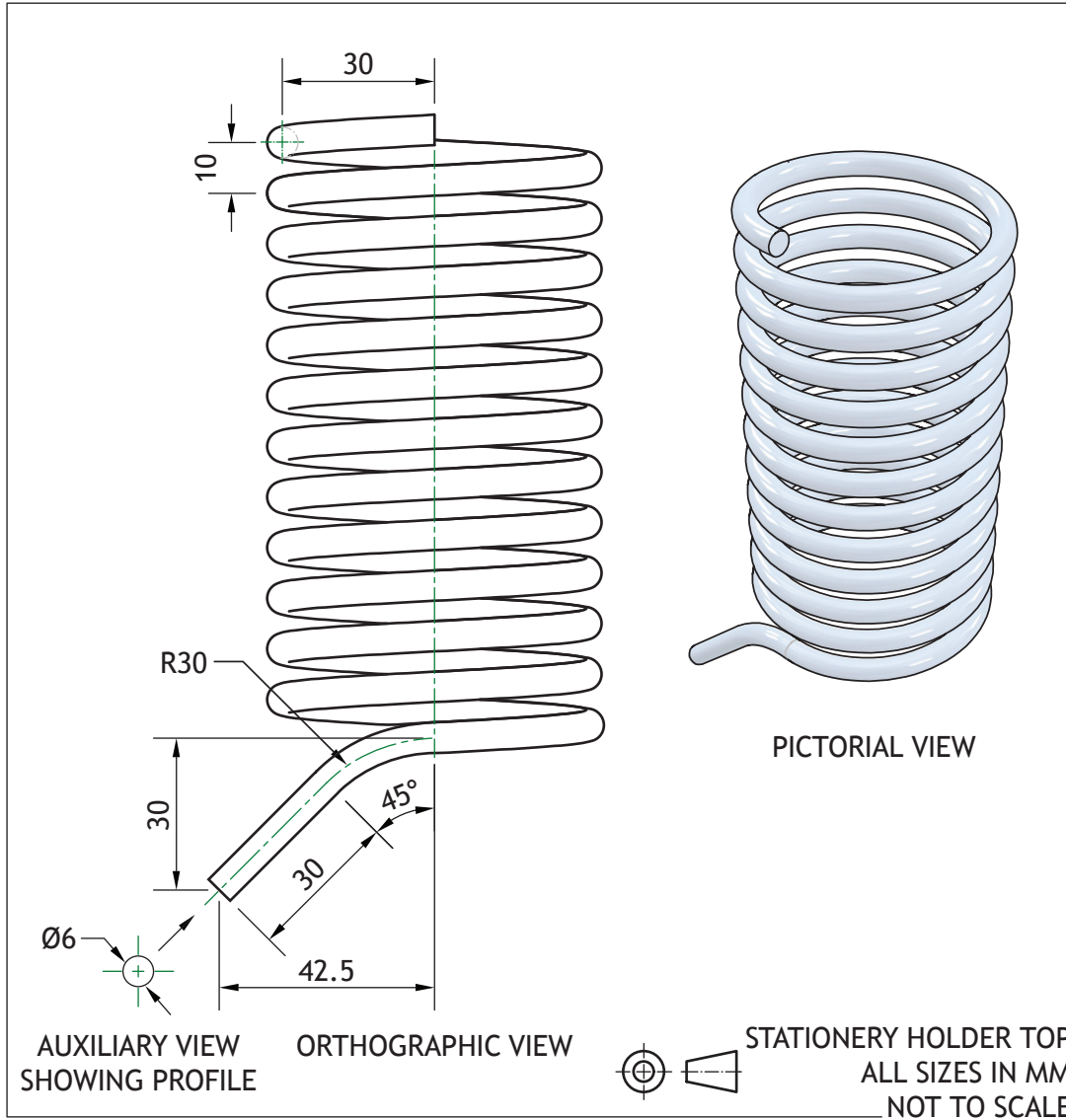

* X 8 3 5 7 6 0 1 1 8 *

4. (continued)

- (b) Describe, using CAD modelling techniques, how to create the stationery holder top.

You must refer to the dimensions given in the drawing.

You may use sketches to support your answer.

6

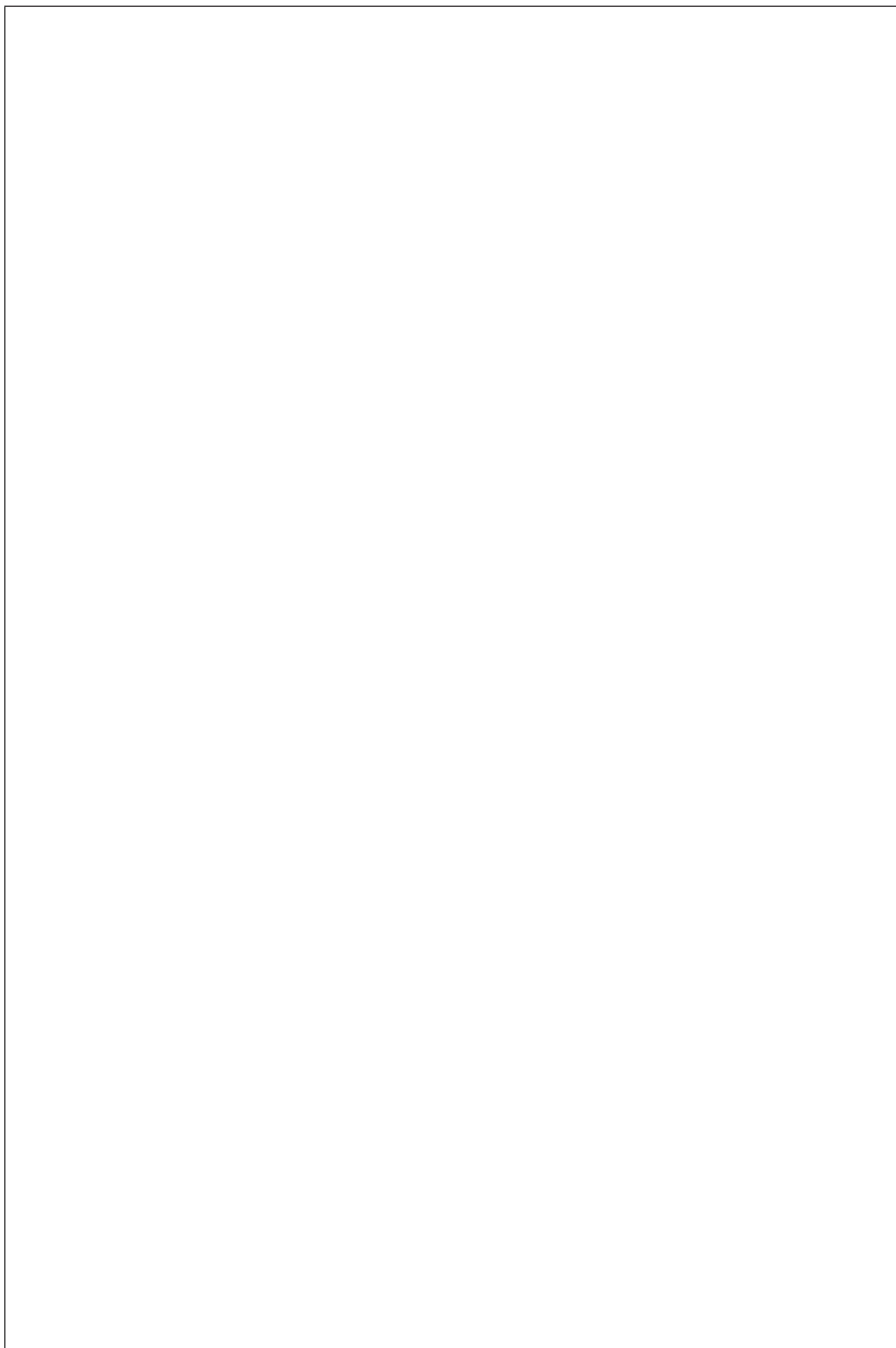

4. (continued)

A drawing for the stationery holder base component was also produced. This is shown below.

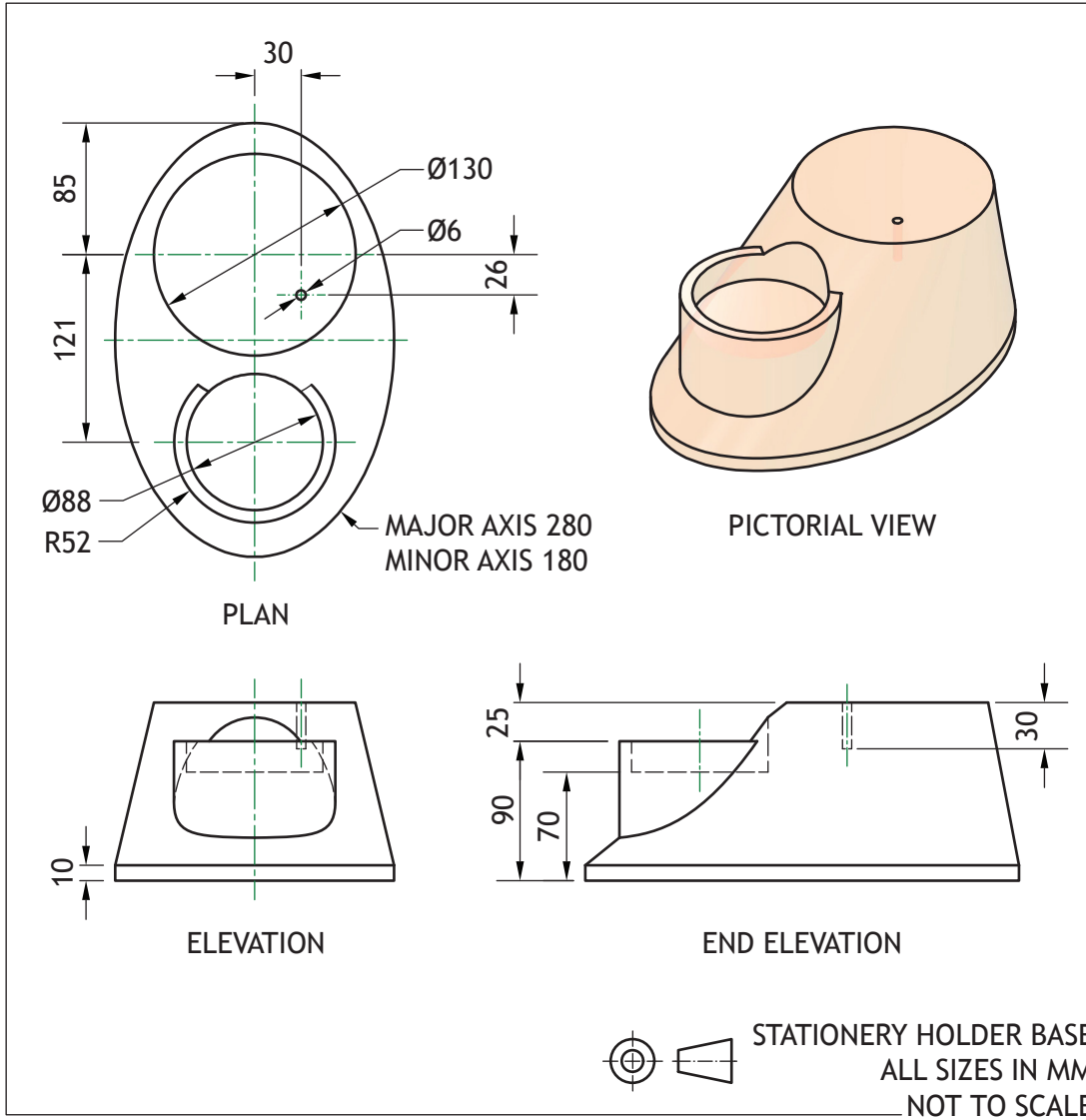

4. (continued)

- (c) Describe, using CAD modelling techniques, how to create the stationery holder base.

You must refer to the dimensions given in the drawing.

You may use sketches to support your answer.

7

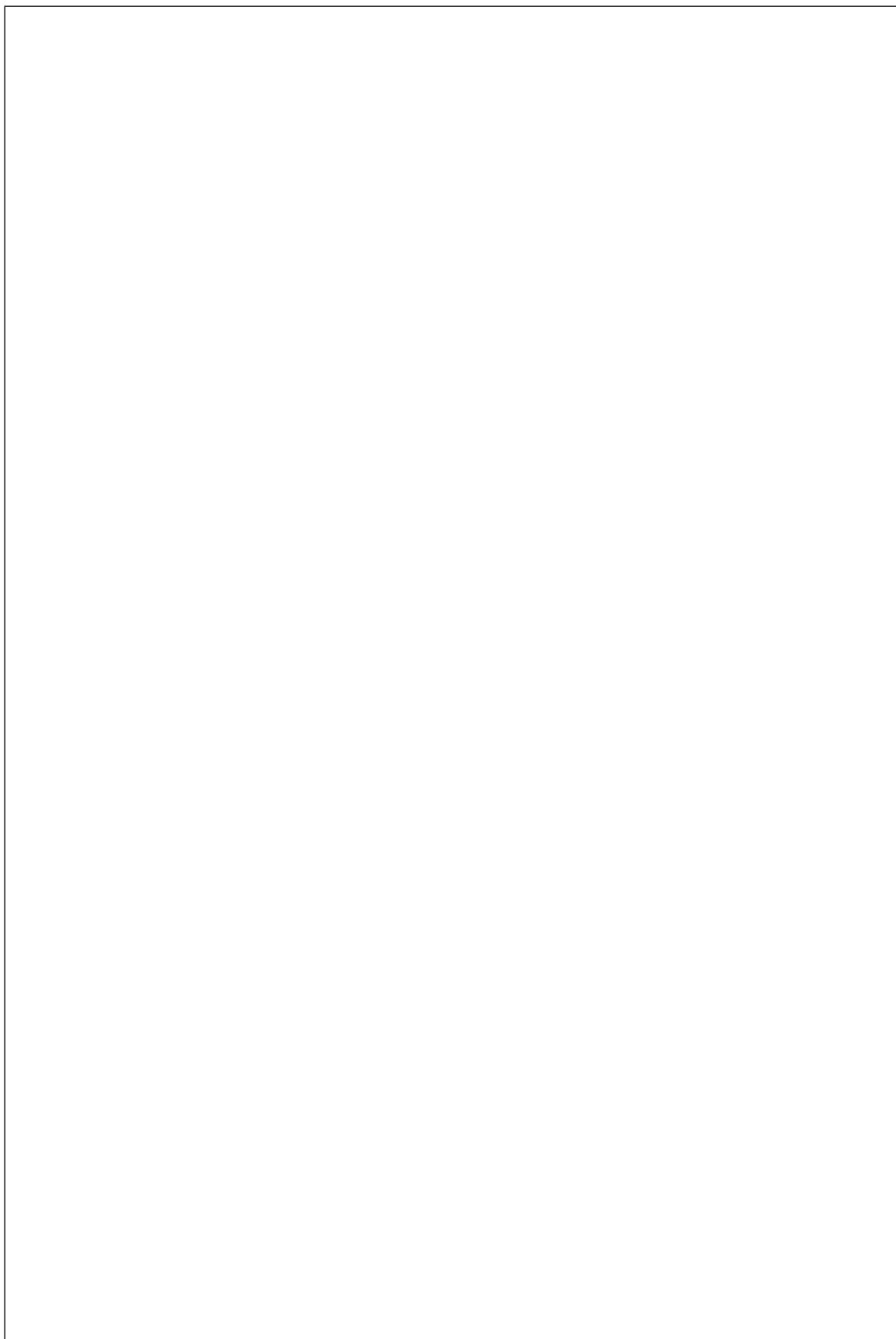

4. (continued)

An additional 3D CAD edit was added to the stationery holder base. This is shown below at **Stage 2**.

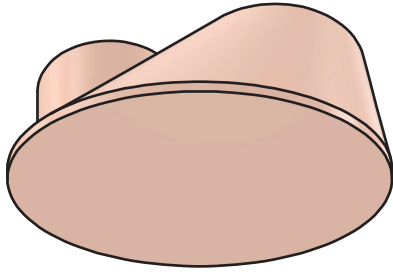

Stage 1

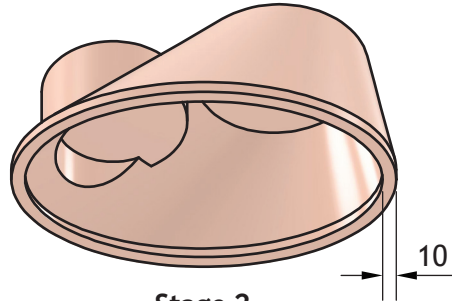

Stage 2

(d) Describe, using CAD modelling techniques, how to create **Stage 2**.

You must refer to the dimension given in the graphic.

You may use sketches to support your answer.

2



[Turn over for next question

DO NOT WRITE ON THIS PAGE



* X 8 3 5 7 6 0 1 2 3 *

4. (continued)

MARKS DO NOT WRITE IN THIS MARGIN

Pictorial and orthographic views of a packaging proposal for the stationery holder are shown below.

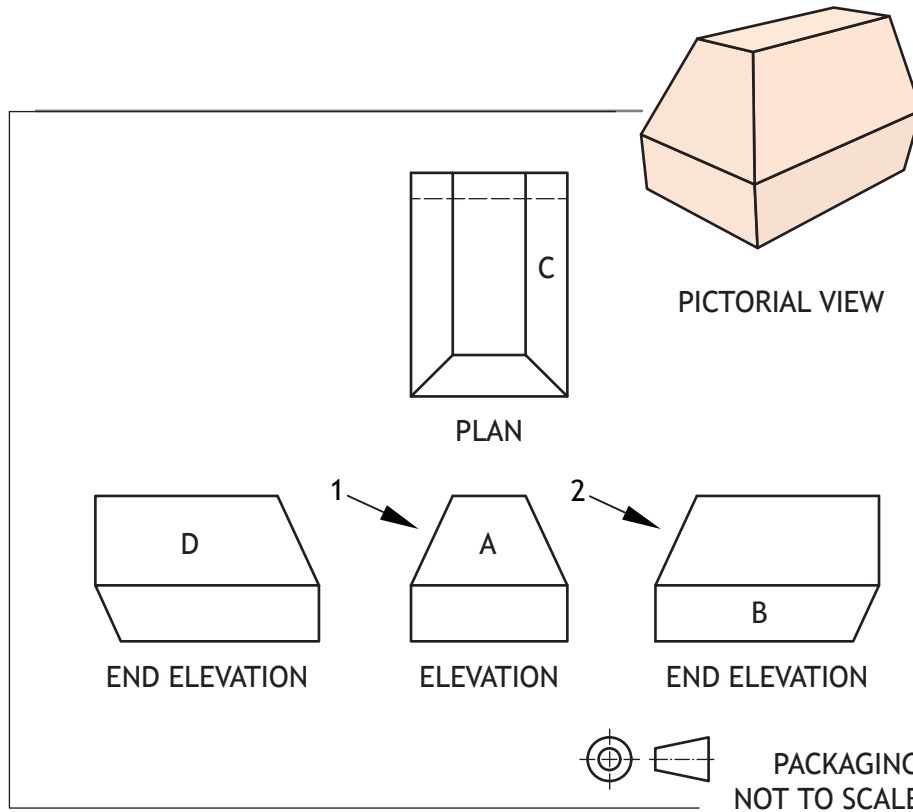

(e) Identify the position of faces A–D on the surface development below. The surface development is shown from the outside.

4

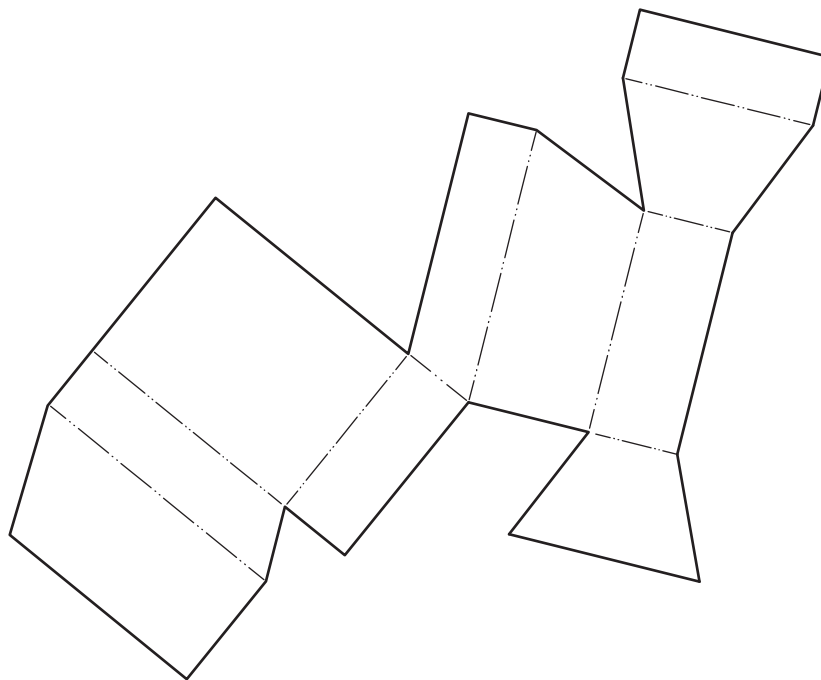

4. (continued)

- (f) (i) Identify the correct auxiliary view of the mount in **direction 1**, shown in the drawing opposite, by ticking (✓) a box below.

1

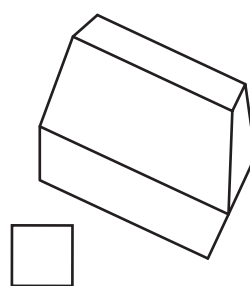
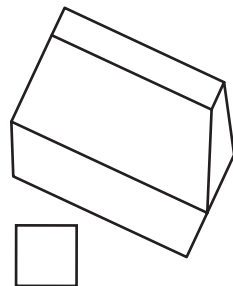
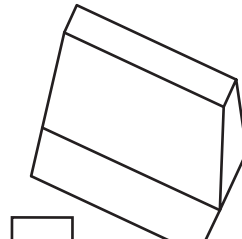
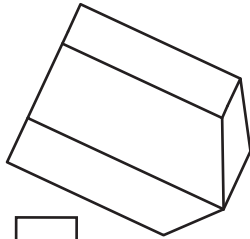

- (ii) Identify the correct auxiliary view of the mount in **direction 2**, shown in the drawing opposite, by ticking (✓) a box below.

1

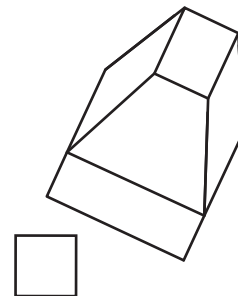
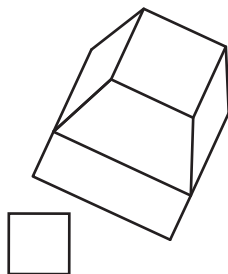
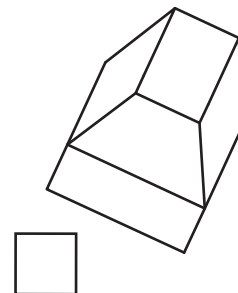
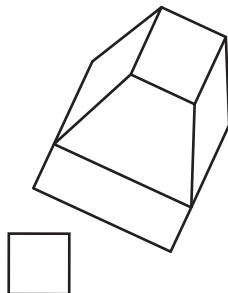

4. (continued)

The files for the packaging proposal are stored in the cloud.

- (g) Explain, giving **two** examples, the benefits to the company of using cloud storage.

2



4. (continued)

MARKS DO NOT WRITE IN THIS MARGIN

A business card was produced for the stationery company.



(h) Describe, giving **two** examples, how the graphic artist has used contrast to enhance the business card.

2

The layout was produced in layers using DTP software.

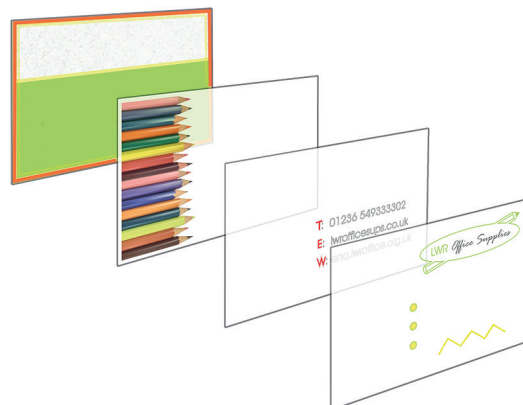

(i) Describe **three** advantages to the graphic artist of using layers to produce the layout.

3



4. (continued)

An online newsletter is available for the general public to view.



(j) Explain three benefits to consumers of reading the newsletter online.

3



5. A concept for a portable HD camera is shown below.

MARKS DO NOT WRITE IN THIS MARGIN

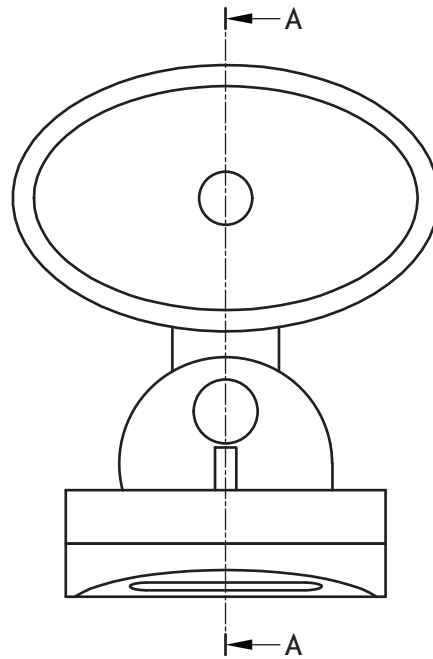

ELEVATION

(a) An incomplete enlarged sectional view of the camera is given below. Using the information provided on the **supplementary sheet for use with question 5 (a)**, complete the sectional view by adding appropriate hatching.

5

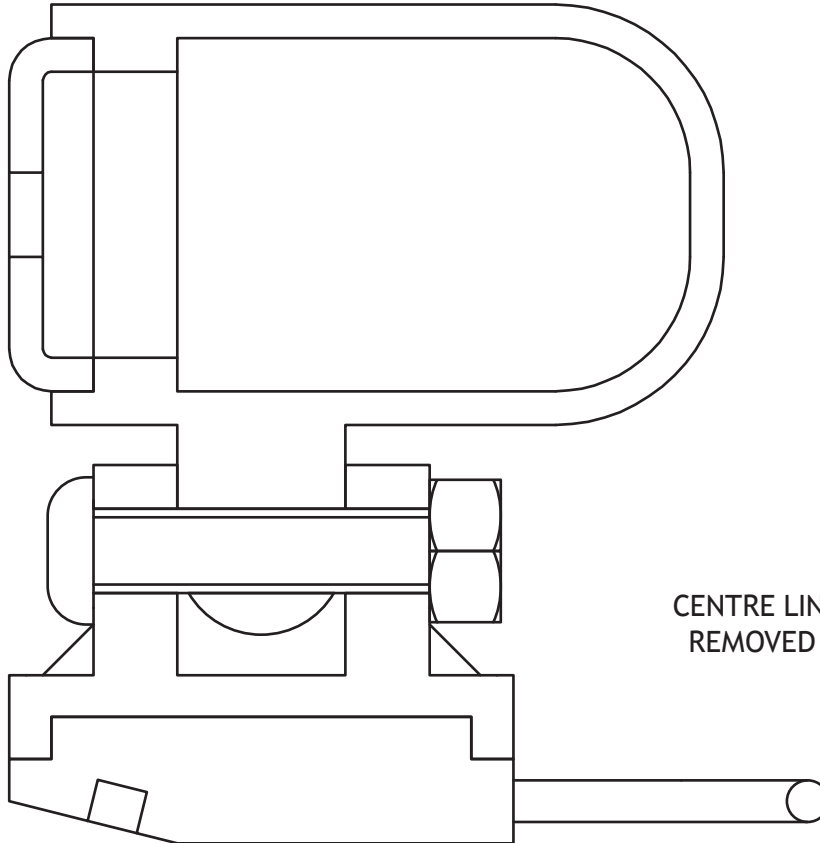

CENTRE LINES HAVE BEEN REMOVED FOR CLARITY



5. (continued)

A full section was produced to show internal detail more clearly.

(b) State the name of two other types of sectional views.

2

1 _____

2 _____



* X 8 3 5 7 6 0 1 3 0 *

5. (continued)

The gap between the uprights on the camera base is 20 mm. A tolerance has been allowed for the 20 mm size.

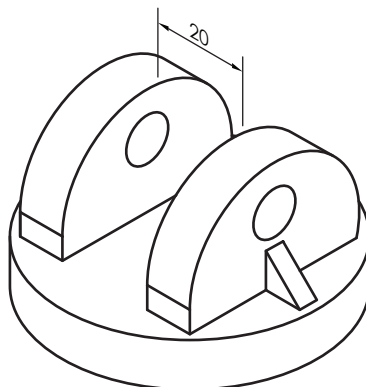

Maximum size of gap between uprights: 20.25

Minimum size of gap between uprights: 19.65

- (c) (i) Apply an asymmetrical tolerance with the correct British Standard conventions to the view below.

2

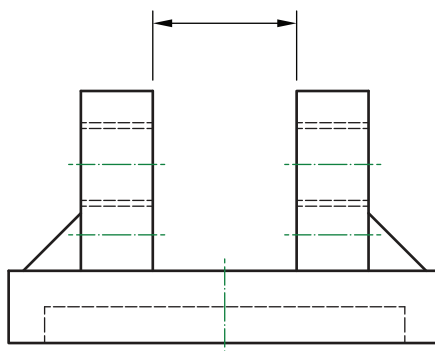

The asymmetrical tolerance above is a functional tolerance.

- (ii) Describe what is meant by the term functional tolerance.

1

[Turn over



5. (continued)

A pictorial illustration of the fixing nut is shown below.

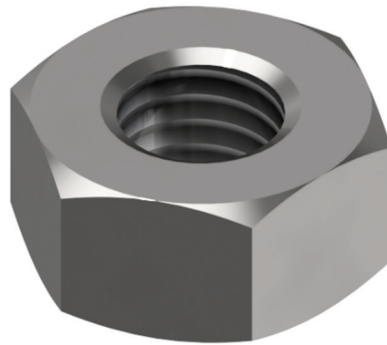

(d) Apply the correct British Standard conventions for an internal thread to the elevation below.

1

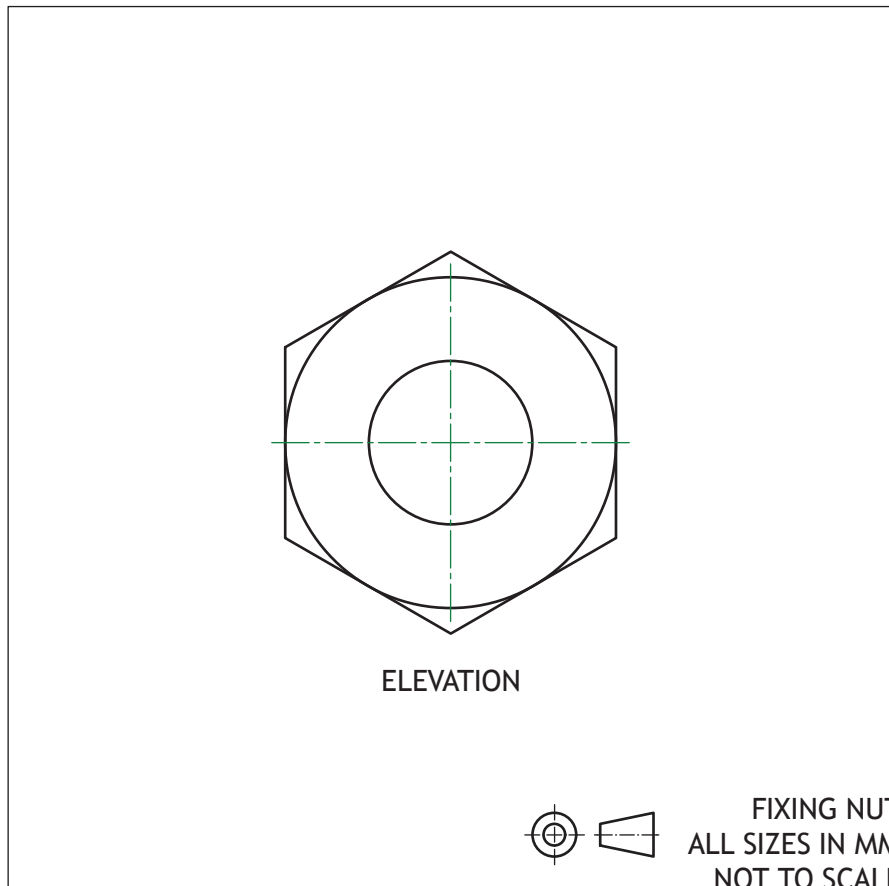

ELEVATION

FIXING NUT
ALL SIZES IN MM
NOT TO SCALE



5. (continued)

MARKS
DO NOT
WRITE IN
THIS
MARGIN

A design concept for an alternate base attachment is shown below.

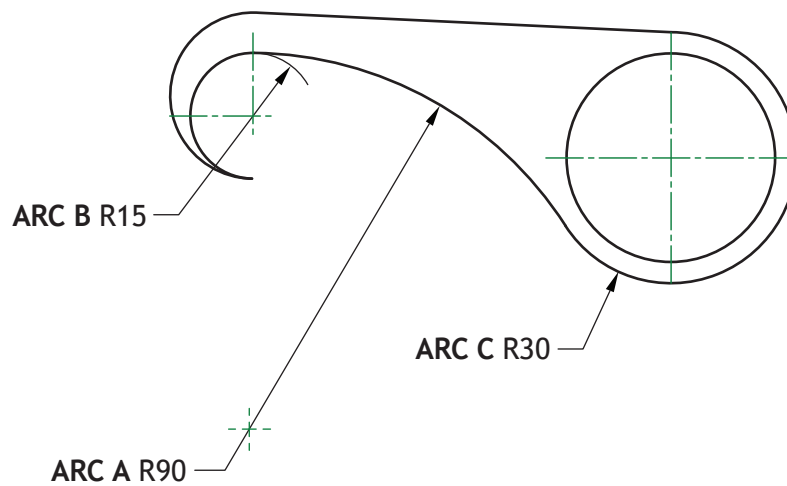

Using the principles of tangency:

- (e) (i) calculate the distance from the centre of Arc A to the centre of Arc B 1

- (ii) calculate the distance from the centre of Arc A to the centre of Arc C. 1

[END OF QUESTION PAPER]



MARKS DO NOT
WRITE IN
THIS
MARGIN

ADDITIONAL SPACE FOR ANSWERS



* X 8 3 5 7 6 0 1 3 4 *

MARKS DO NOT
WRITE IN
THIS
MARGIN

ADDITIONAL SPACE FOR ANSWERS



* X 8 3 5 7 6 0 1 3 5 *

MARKS DO NOT
WRITE IN
THIS
MARGIN

ADDITIONAL SPACE FOR ANSWERS



* X 8 3 5 7 6 0 1 3 6 *