

FOR OFFICIAL USE



--	--	--	--	--	--

National
Qualifications
2023

Mark

--

X840/76/01

**Human Biology
Paper 2**

THURSDAY, 27 APRIL

10:10 AM – 12:30 PM



* X 8 4 0 7 6 0 1 *

Fill in these boxes and read what is printed below.

Full name of centre

--

Town

--

Forename(s)

--

Surname

--

Number of seat

--

Date of birth

Day

--	--

Month

--	--

Year

--	--

Scottish candidate number

--	--	--	--	--	--	--	--	--	--

Total marks — 95

Attempt ALL questions.

You may use a calculator.

Question 15 contains a choice.

Write your answers clearly in the spaces provided in this booklet. Additional space for answers and rough work is provided at the end of this booklet. If you use this space you must clearly identify the question number you are attempting. Any rough work must be written in this booklet. Score through your rough work when you have written your final copy.

Use **blue** or **black** ink.

Before leaving the examination room you must give this booklet to the Invigilator; if you do not, you may lose all the marks for this paper.



* X 8 4 0 7 6 0 1 0 1 *

Total marks — 95
 Attempt ALL questions
 Question 15 contains a choice

1. The diagram represents the structure of a section of DNA.

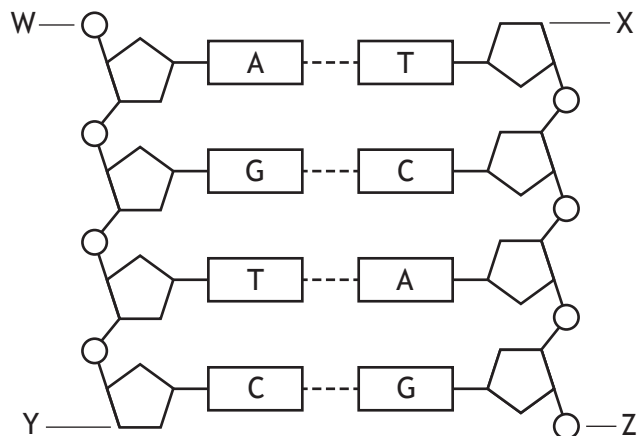

- (a) (i) Name the repeating units that make up DNA. 1

- (ii) Name the parts of these units, joined by strong bonds, that make up the backbone of DNA. 1
 _____ and _____
- (iii) Identify one letter from the diagram that labels the 3' end of a DNA strand. 1



1. (continued)

- (b) (i) The first stage in the production of a protein involves the synthesis of mRNA from a section of DNA.

Name this stage.

1

- (ii) Describe how alternative RNA splicing can produce different proteins from one gene.

1

- (iii) Describe the function of tRNA in protein synthesis.

2

[Turn over



* X 8 4 0 7 6 0 1 0 3 *

2. (a) The diagram represents stages of an enzyme-catalysed reaction.

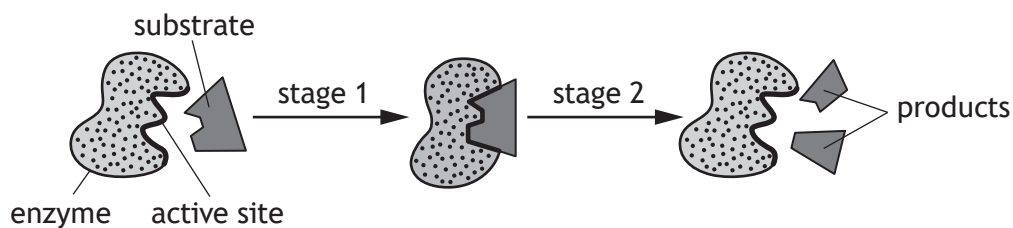

(i) Use the diagram to explain why this reaction can be described as catabolic.

1

(ii) The diagram shows induced fit occurring between the enzyme and its substrate molecule.

Describe what happens during induced fit.

1

(iii) Once the reaction is complete the products are released from the active site and the enzyme can be reused.

Explain why the products leave the active site.

1



2. (continued)

- (b) Parkinson's disease is caused by low levels of dopamine in the brain resulting in poor muscle co-ordination. Parkinson's disease can be treated using the drug L-dopa, which is converted to dopamine in the brain.

L-dopa is produced commercially in a reaction vessel using the enzyme tyrosinase as shown.

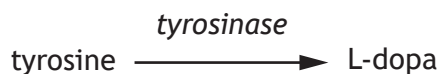

The graph shows the results of using different concentrations of the substrate tyrosine on the concentration of L-dopa produced in the reaction vessel.

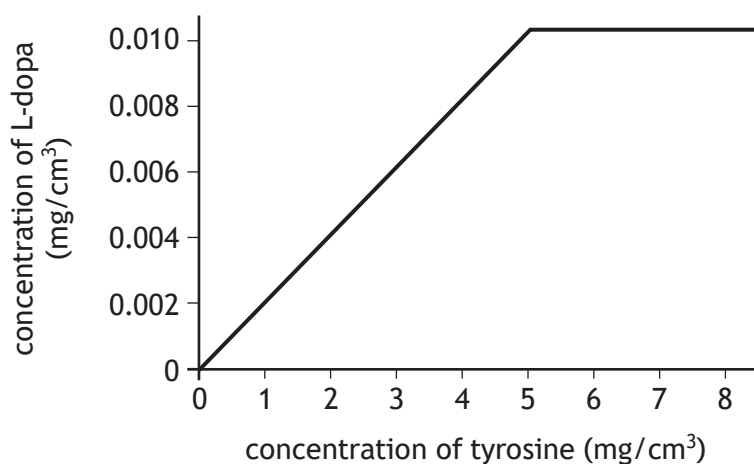

Using information from the graph, suggest why a tyrosine concentration of 5 mg/cm³ is used in the commercial production of L-dopa.

1

- (c) Many enzymes are used in commercial processes. When using enzymes in these processes the end-product is regularly removed.

Suggest why end-products are removed during production processes.

1

[Turn over



3. Succinate is converted to fumarate by a dehydrogenase enzyme as shown.

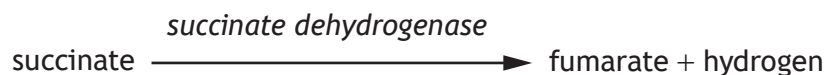

The rate of this reaction can be measured using the indicator DCPIP, which changes colour from blue to colourless when it combines with hydrogen.

An investigation was carried out into the effect of an inhibitor on the rate of this reaction at different concentrations of succinate.

Five test tubes were set up as shown in the diagram, each test tube contained a different concentration of succinate.

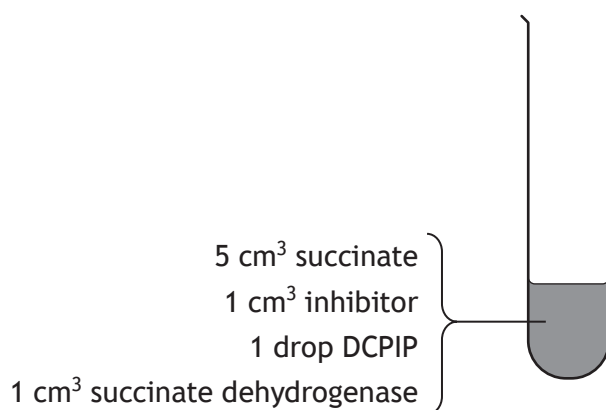

The time to decolourise the DCPIP indicator in each tube was measured.

The investigation was repeated without the inhibitor.

The results of the investigation are shown in the table.

Concentration of succinate (M)	Time to decolourise DCPIP (s)	
	With inhibitor	Without inhibitor
0.2	94	72
0.4	48	30
0.6	24	16
0.8	14	8
1.0	8	8

- (a) (i) State one variable, other than those mentioned, that would need to be controlled for a valid conclusion to be drawn.

1



3. (a) (continued)

MARKS DO NOT WRITE IN THIS MARGIN

(ii) Describe one possible source of error when using DCPIP in this investigation.

1

(iii) Suggest how the reliability of the results in this investigation could be improved.

1

(b) Draw a line graph to show the results of the investigation **with inhibitor**.
(Additional graph paper, if required, can be found on *page 30*.)

2

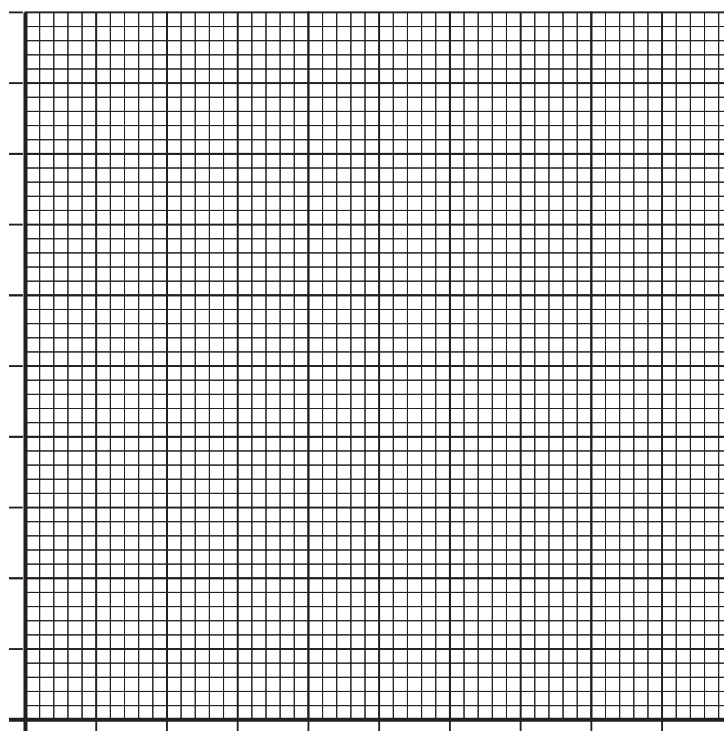

(c) Describe how the results show that the inhibitor used is a competitive inhibitor of succinate dehydrogenase.

1



3. (continued)

(d) Succinate is a metabolite in the citric acid cycle.

(i) State the exact location of the citric acid cycle in a cell.

1

(ii) Describe the role of dehydrogenase enzymes in the citric acid cycle.

1

(iii) Name the substance that combines with an acetyl group to form citrate during the citric acid cycle.

1



* X 8 4 0 7 6 0 1 0 8 *

4. (a) Individuals with sickle cell disease have a form of haemoglobin called haemoglobin S, which is less efficient at carrying oxygen. The diagram shows how a mutation in the gene coding for haemoglobin causes the production of haemoglobin S.

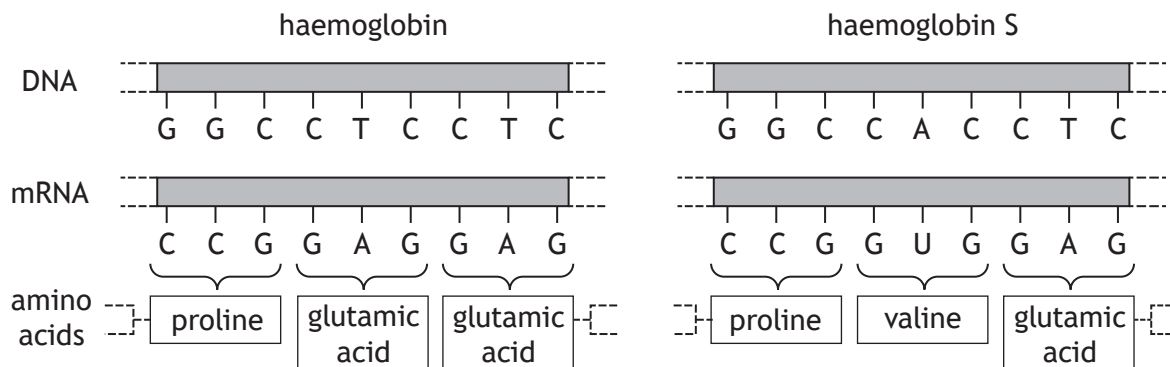

- (i) Sickle cell disease is caused by a substitution mutation.

Describe evidence from the diagram that supports this statement.

1

- (ii) Suggest how changing one amino acid could cause the haemoglobin S protein to function less effectively than haemoglobin.

1

- (b) Compare the effects of frame-shift and missense mutations on the resulting sequence of amino acids in a protein.

2

[Turn over



4. (continued)

- (c) An individual with sickle cell disease has the homozygous genotype SS. All their haemoglobin is type S. Their red blood cells can develop a distorted sickle shape and are stickier than normal red blood cells.

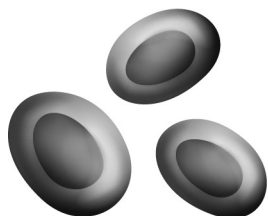

normal red blood cells



sickle shaped red blood cells

An individual with sickle cell trait has the heterozygous genotype HS. Their red blood cells contain both forms of haemoglobin.

- (i) Explain why the inheritance of sickle cell trait is an example of incomplete dominance. 1
- _____
- _____
- (ii) Suggest why individuals with sickle cell disease have an increased risk of having a stroke. 1
- _____
- _____
- (iii) When the population of the UK was 67 620 000, one in every 4600 people had sickle cell disease. 1
- Calculate how many people had sickle cell disease.
- Space for calculation*
- _____



5. The diagram represents six developmental stages that may be seen within an ovary during a menstrual cycle.

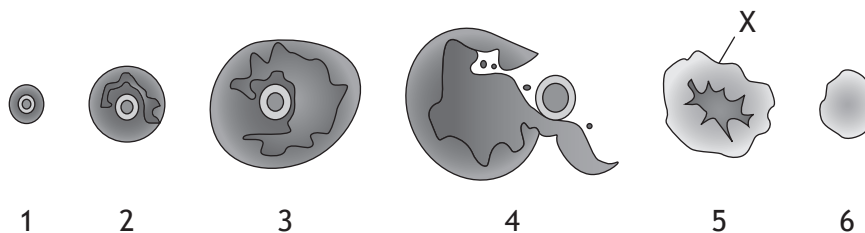

(a) (i) State which of the numbered stages represents ovulation. 1

(ii) Name structure X. 1

(b) At the end of the menstrual cycle progesterone concentration decreases.

(i) Describe the process that leads to this decrease. 2

(ii) Describe one effect of the decrease in progesterone concentration. 1

(c) One treatment for infertility in women is to administer drugs to stimulate ovulation.

Describe the action of these drugs. 1

[Turn over



6. In vitro fertilisation (IVF) is a fertility treatment, which may involve several treatment cycles.

Graph 1 contains information about the success rate of different treatment cycles of IVF in the UK in a year. It also shows the average age of women undergoing each treatment cycle.

Graph 1

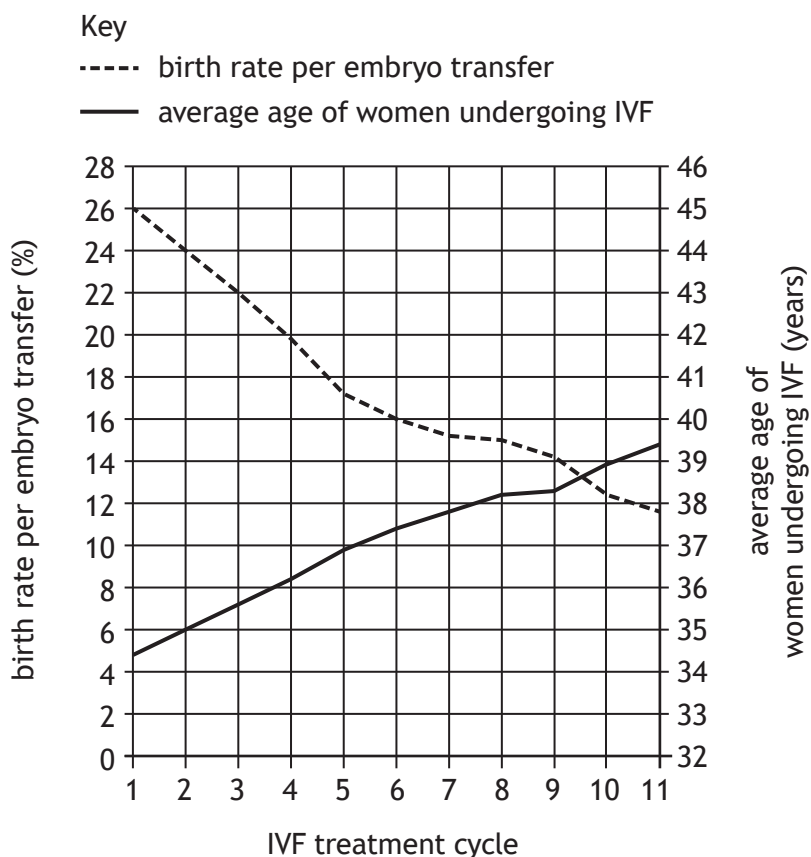

(a) (i) Describe the two key trends shown in the graph. 2

1. _____

2. _____

(ii) State the average age of women undergoing IVF when the birth rate per embryo transfer is 24%. 1

_____ years



6. (continued)

MARKS DO NOT WRITE IN THIS MARGIN

- (b) The table shows the number of women undergoing IVF and the number of embryos transferred during each treatment cycle.

IVF treatment cycle	Number of women undergoing IVF	Number of embryos transferred
1	23 400	24 000
3	9815	12 143
5	2800	3694
7	800	1119
9	300	341
11	220	300

- (i) Calculate the percentage decrease in the number of women undergoing 11 treatment cycles of IVF compared to the number undergoing 1 treatment cycle of IVF.

1

Space for calculation

_____ %

- (ii) Using data from the table and Graph 1, calculate the number of babies born after 1 treatment cycle of IVF.

1

Space for calculation

- (iii) Explain why the birth rate per embryo transfer for each IVF treatment cycle is expressed as a percentage in Graph 1.

1



6. (continued)

- (c) Graph 2 shows the relationship between the age of women undergoing IVF and the birth rate per embryo transfer for women using their own eggs and donor eggs.

Graph 2

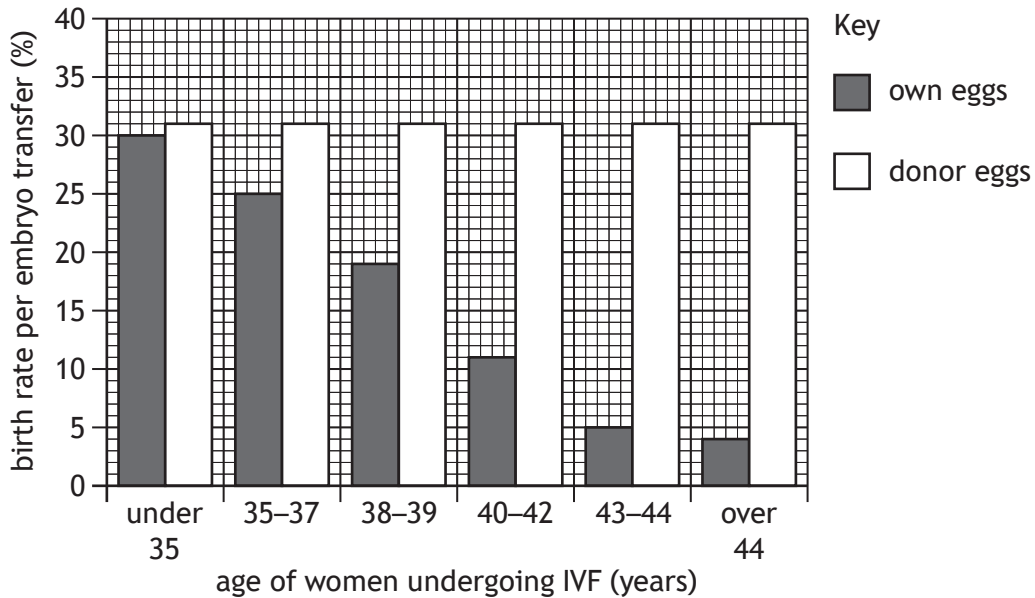

- (i) State the difference in the birth rate per embryo transfer for women over 44 who use donor eggs instead of their own.

1

_____ %

- (ii) Describe how age affects the birth rate per embryo transfer when women's own eggs are used compared to using donor eggs.

1

- (iii) Suggest why the birth rate per embryo transfer is higher for donor eggs.

1



7. The three main types of blood vessels are arteries, capillaries and veins.

(a) The diagram shows cross sections through two of these blood vessels.

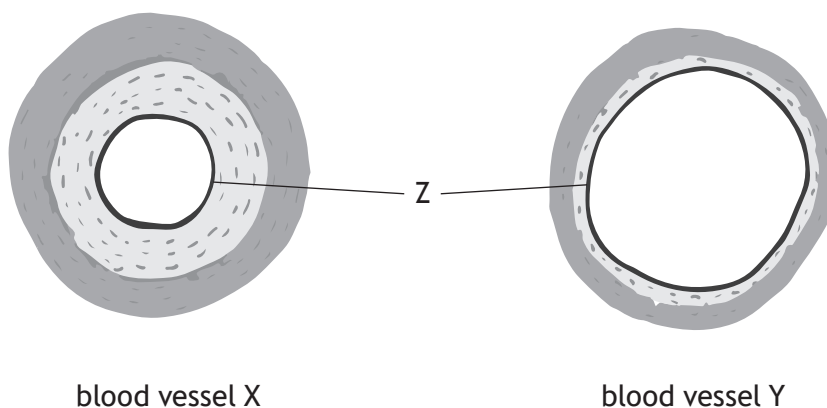

(i) Blood vessel X is an artery and Y is a vein.

Describe one feature shown in the diagram that confirms this.

1

(ii) Name layer Z.

1

(b) Describe the exchange of materials between blood plasma in capillaries and body cells.

3

[Turn over



8. The diagram shows muscle damage in the heart of an individual who has had a heart attack.

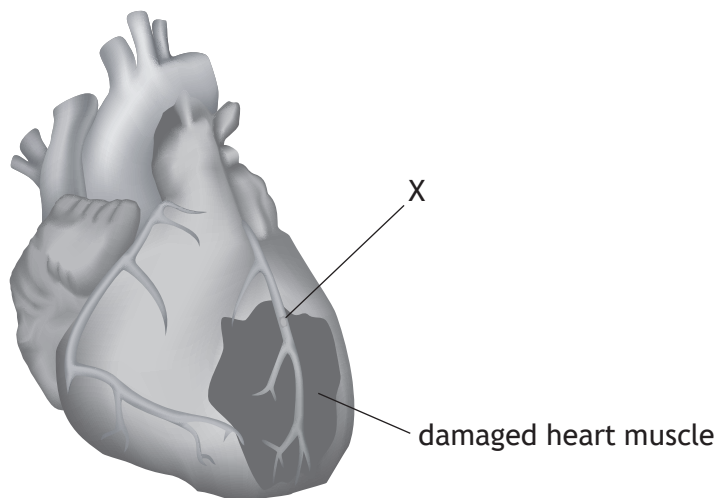

(a) (i) Name blood vessel X.

1

(ii) Explain how the formation of a thrombus in blood vessel X results in heart muscle damage.

1

(b) Suggest why statins are prescribed to individuals to reduce the risk of a heart attack.

2



8. (continued)

(c) Obesity is a major risk factor in the development of cardiovascular disease. BMI can be used to measure obesity.

(i) State the minimum BMI value that indicates obesity.

1

(ii) Calculate the mass of an individual who is 1.8 m tall with a BMI of 35.8.

1

Space for calculation

_____ kg

[Turn over



* X 8 4 0 7 6 0 1 1 7 *

9. Research has shown that some individuals who are obese can prevent the onset of type 2 diabetes by reducing their body mass.

(a) Name the test used to diagnose diabetes.

1

(b) An individual who weighed 120 kg was advised that they were at risk of developing type 2 diabetes. It was recommended that they reduce their body mass by 5%.

Calculate the individual's target body mass.

1

Space for calculation

_____ kg

(c) Describe how type 2 diabetes affects liver cells.

2

(d) Describe how untreated diabetes may damage the retina.

1



10. The diagram shows a motor neuron from an adult.

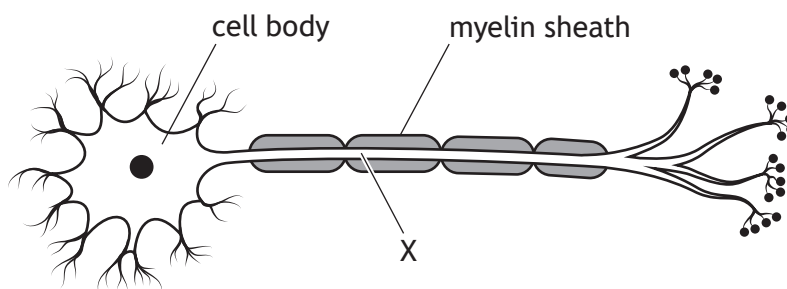

(a) (i) Name structure X. 1

(ii) State why it is important that structure X is insulated by the myelin sheath. 1

(iii) Name the type of cell that produces the myelin sheath. 1

(b) Explain how the structure of motor neurons causes a one year old child to be less coordinated than an adult. 1

(c) Motor neurons are often part of diverging neural pathways.
State one advantage of neurons being arranged in a diverging pathway. 1

[Turn over



11. The diagram shows how neurons of the autonomic nervous system connect to some body organs.

Key
 ----- sympathetic neuron
 _____ parasympathetic neuron

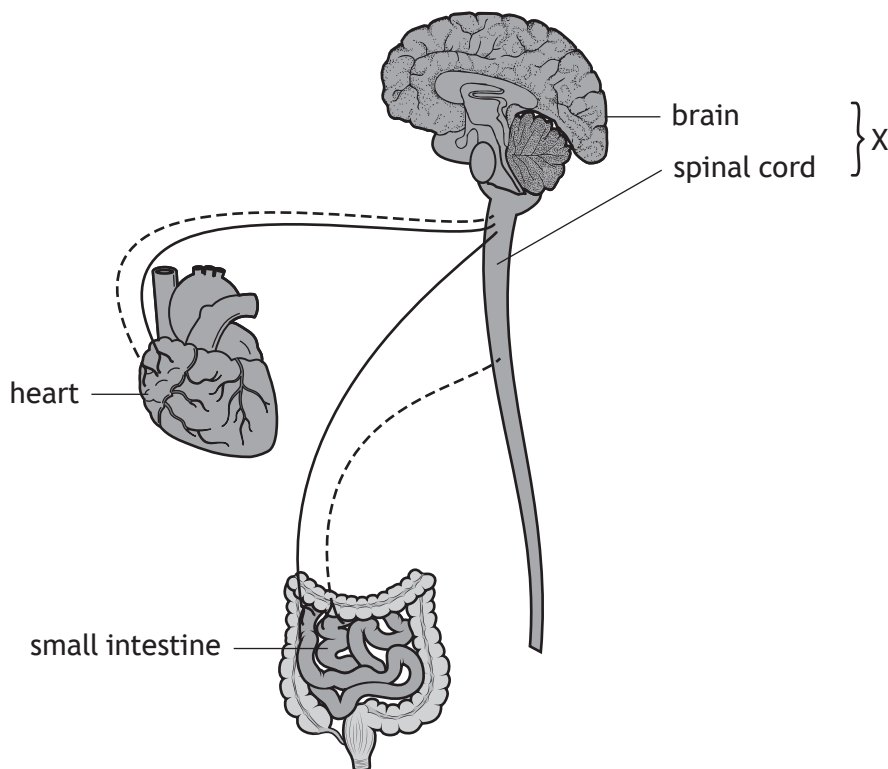

(a) Name the system identified by X.

1

(b) (i) State the term that describes the opposing effect of the sympathetic and parasympathetic nervous systems on body organs.

1



11. (b) (continued)

- (ii) During exercise, stimulation by sympathetic neurons increases heart rate and causes vasoconstriction of arteries in the small intestine.

Explain the importance of increased heart rate and vasoconstriction of arteries in the small intestine during exercise.

2

Increased heart rate _____

Vasoconstriction of arteries in small intestine _____

[Turn over



* X 8 4 0 7 6 0 1 2 1 *

12. An investigation was carried out into the effect of background rock music on the ability to recall words in a list.

Students of the same age were arranged into two groups of 20. At the same time of day, each group listened to a list of 10 words being read aloud.

While the words were being read out, one group was played rock music. After the words were read out the music was stopped, and each student was asked to write down the words they had heard.

The other group was a control group.

The results are shown in the tables.

Rock music group	
Position of word in list	Number of students recalling word
1	19
2	18
3	15
4	9
5	5
6	3
7	3
8	12
9	17
10	19

Control group	
Position of word in list	Number of students recalling word
1	20
2	19
3	17
4	12
5	7
6	6
7	6
8	14
9	19
10	20

- (a) State two variables, other than those described above, that would need to be controlled during this investigation.

2

1. _____

2. _____

- (b) Calculate the difference between the two groups in the average number of words recalled per student.

1

Space for calculation



12. (continued)

(c) Describe the control that was set up for this investigation.

1

(d) State the conclusion that can be drawn from the results of the investigation.

1

(e) Explain why there is an increase in the number of students recalling the words towards the end of the list.

1

[Turn over



13. After exercise, some individuals experience a pleasant feeling known as 'runner's high' due to the production of endorphins.

(a) The graph shows the effect of the intensity of exercise on endorphin and lactate concentrations in the blood of an individual.

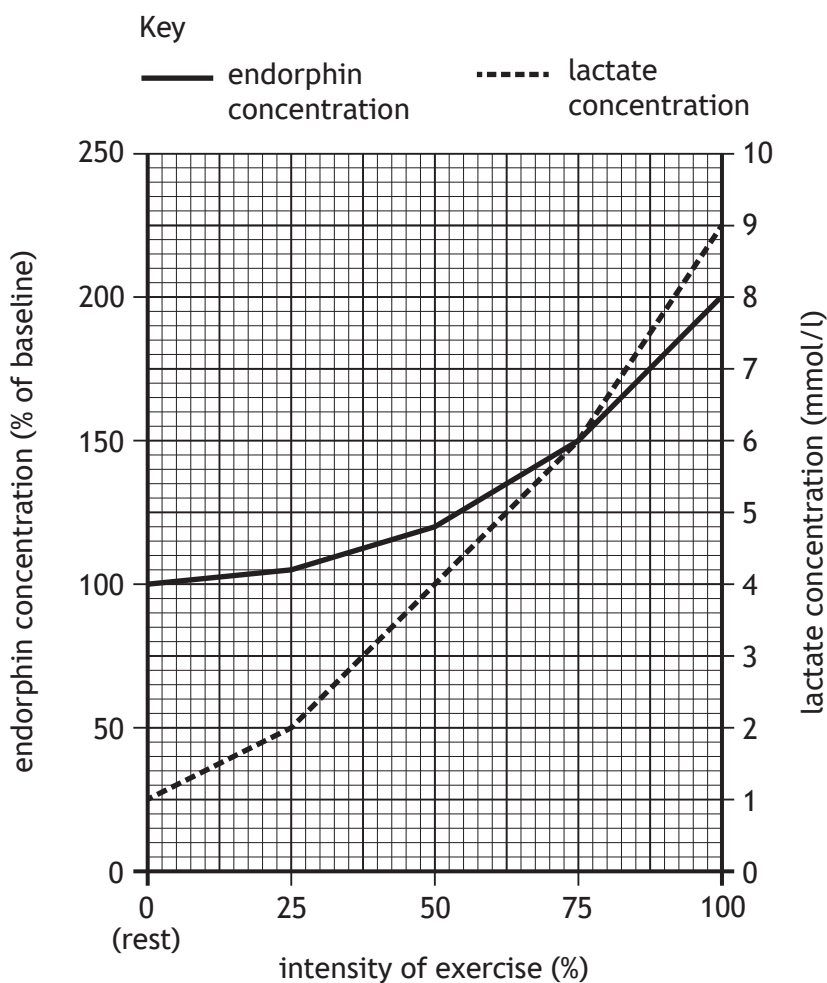

(i) State the endorphin concentration when the lactate concentration was 2 mmol/l.

1

_____ % of baseline

(ii) Calculate the percentage increase in lactate concentration as the intensity of exercise increased from 50% to 100%.

1

Space for calculation

_____ %



13. (a) (continued)

(iii) Explain why lactate concentration increases as the intensity of exercise increases.

2

(b) State one activity, other than exercise, that may increase endorphin levels.

1

[Turn over



* X 8 4 0 7 6 0 1 2 5 *

13. (continued)

- (c) The table shows the results of an investigation to compare endorphin concentrations in two individuals of different fitness levels after exercise.

Duration of exercise (minutes)	Endorphin concentration (% of baseline)	
	Fit individual	Unfit individual
0	100	100
30	110	112
60	140	138
90	160	160

- (i) Express, as a simple whole number ratio, the endorphin concentration after 30 minutes of exercise compared to after 90 minutes in an unfit individual.

1

Space for calculation

_____ : _____
30 minutes 90 minutes

- (ii) The investigation shows that endorphin levels increase as the duration of exercise increases.

1

State one other conclusion that can be drawn from this investigation.



14. Tetanus is a disease caused by a type of bacteria. Tetanus bacteria live in soil and enter the body from the soil through wounds in the skin.

(a) State the term that describes disease-causing organisms such as tetanus bacteria.

1

(b) When bacteria enter the body, phagocytes often destroy them. Describe how phagocytes destroy bacteria.

2

(c) Phagocytes release chemicals called cytokines at the wound site. Describe one function of cytokines.

1

(d) Tetanus bacteria produce a toxin. One of the actions of this toxin is to bind to pre-synaptic membranes in synapses between neurons and muscle fibres.

Suggest why binding of this toxin to pre-synaptic membranes would decrease the transmission of impulses to muscle fibres.

1

(e) Explain why herd immunity would **not** protect unvaccinated individuals against tetanus.

1

[Turn over



15. Attempt either A or B.

Write your answer in the space below and on *page 29*.

A Describe the mode of action of recreational drugs and the effects on the body of their repeated use.

8

OR

B Describe the contents of vaccines and the design of clinical trials used to establish their effectiveness.

8

You may use labelled diagrams where appropriate.



* X 8 4 0 7 6 0 1 2 8 *

MARKS DO NOT
WRITE IN
THIS
MARGIN

ADDITIONAL SPACE FOR ANSWER to question 15

[END OF QUESTION PAPER]



* X 8 4 0 7 6 0 1 2 9 *

ADDITIONAL SPACE FOR ANSWERS AND ROUGH WORK

Additional graph paper for question 3 (b)

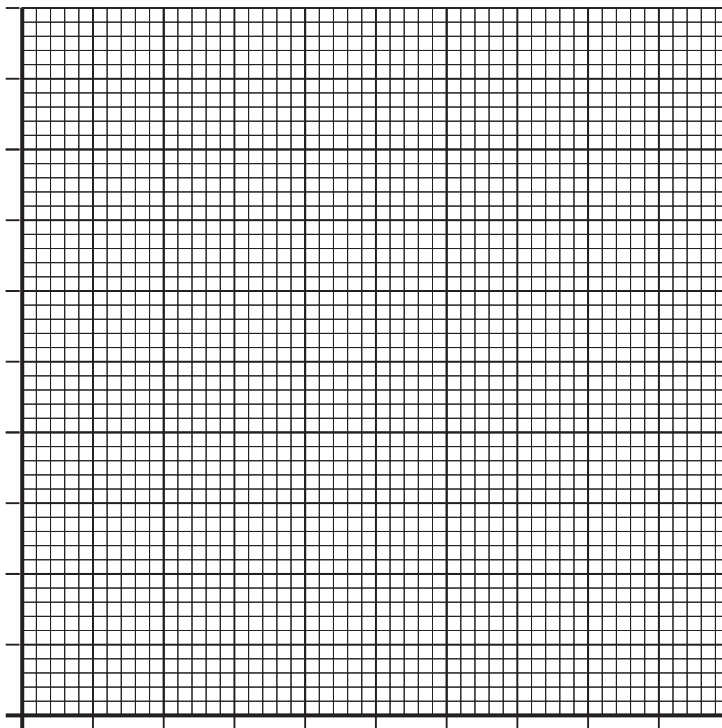

MARKS DO NOT
WRITE IN
THIS
MARGIN

ADDITIONAL SPACE FOR ANSWERS AND ROUGH WORK



* X 8 4 0 7 6 0 1 3 1 *

MARKS DO NOT
WRITE IN
THIS
MARGIN

ADDITIONAL SPACE FOR ANSWERS AND ROUGH WORK

Acknowledgement of copyright

Question 8 Maniki_rus/shutterstock.com



* X 8 4 0 7 6 0 1 3 2 *