



National
Qualifications
2025

X840/76/12

**Human Biology
Paper 1 — Multiple choice**

TUESDAY, 27 MAY

9:00 AM – 9:40 AM

Total marks — 25

Attempt ALL questions.

You may use a calculator.

Instructions for the completion of Paper 1 are given on *page 02* of your answer booklet X840/76/02.

Record your answers on the answer grid on *page 03* of your answer booklet.

Space for rough work is provided at the end of this booklet.

Before leaving the examination room you must give your answer booklet to the Invigilator; if you do not, you may lose all the marks for this paper.



* X 8 4 0 7 6 1 2 *

Total marks — 25
Attempt ALL questions

1. The diagram shows part of a DNA molecule.

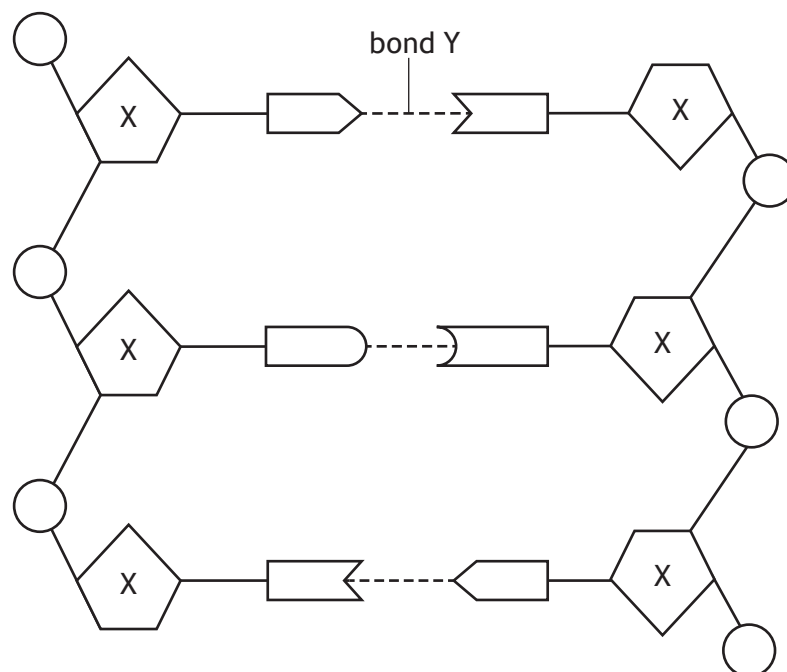

Which row in the table identifies sugar X and bond Y?

	Sugar X	Bond Y
A	deoxyribose	hydrogen
B	ribose	peptide
C	deoxyribose	peptide
D	ribose	hydrogen

2. The role of DNA polymerase is to

- A remove introns from a primary mRNA transcript
- B add DNA nucleotides to a new DNA strand being formed
- C synthesise a primary mRNA transcript during transcription
- D join DNA fragments together during replication of the lagging strand.

3. The graph shows the percentage of new cases of testicular cancer and the percentage survival rate across a range of age groups.

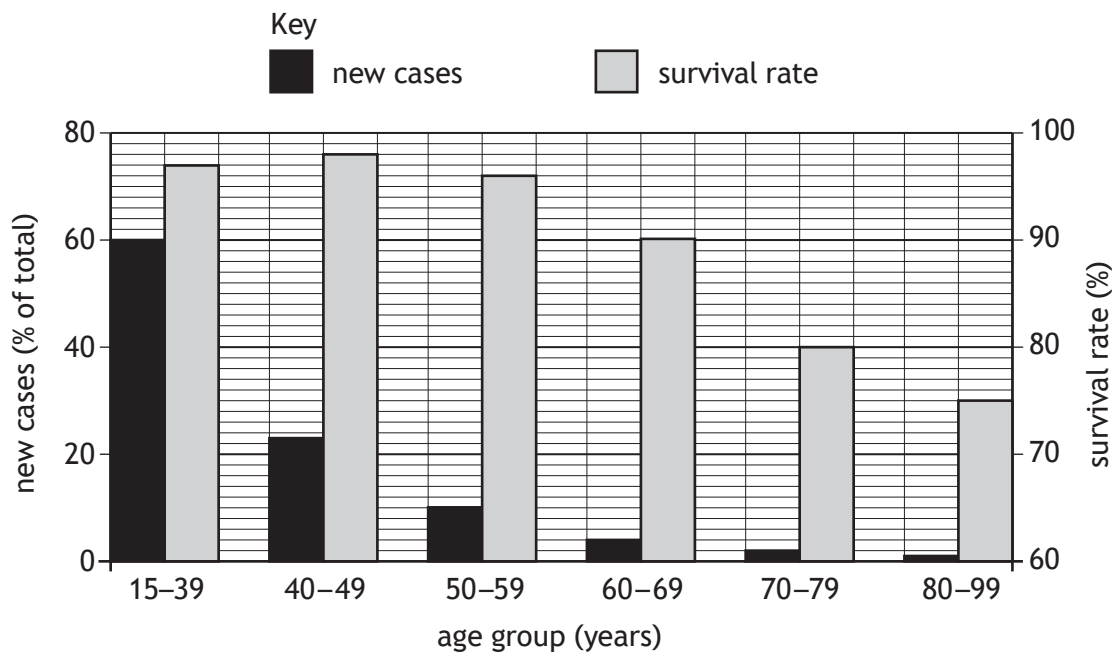

Which of the following is correct for this data?

- A The ratio of survival rate to new cases for age group 50–59 is 48:5.
- B The difference in survival rate between age groups 60–69 and 70–79 is 20%.
- C The percentage of new cases at age group 40–49 is double that of age group 50–59.
- D The age group with the highest percentage of new cases has the highest survival rate.
4. Which types of RNA can be found in the cytoplasm?

- A mRNA only
- B tRNA and rRNA only
- C mRNA and rRNA only
- D mRNA, tRNA and rRNA

5. The nucleic acids involved in gene expression are listed.

1. DNA
2. mRNA
3. tRNA
4. rRNA

Which nucleic acids are involved in the transcription stage of gene expression?

- A 1 only
- B 1 and 2 only
- C 1, 2 and 3 only
- D 1, 2, 3 and 4

6. PCR is a reaction that amplifies a section of DNA and involves several temperature changes per cycle.

The reaction stays at each temperature for 2 minutes.

Calculate the total number of minutes taken to produce 128 copies of one DNA section.

- A 14
B 21
C 42
D 64
7. Pharmacogenetics is the use of
- A gene sequences to assess the likelihood of passing on a disease
B computer programs to assess the likelihood of passing on a disease
C gene sequences to select appropriate drug and dosage to treat a disease
D computer programs to identify base sequences of known genetic diseases.
8. The diagram shows the metabolic pathway that converts the amino acid threonine into isoleucine.

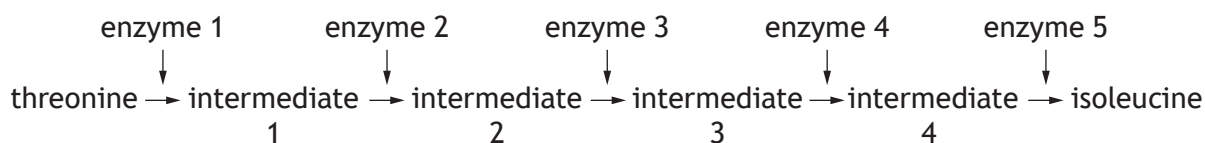

An increased production of isoleucine would be caused by

- A isoleucine acting as a competitive inhibitor of enzyme 2
B negative feedback inhibition of threonine by isoleucine
C an increased concentration of isoleucine
D an increased concentration of threonine.
9. During vigorous exercise not enough oxygen is delivered to cells to support the electron transport chain.
- To allow glycolysis to continue, pyruvate is converted to
- A acetyl, generating NAD
B lactate, generating NAD
C acetyl, generating NADH
D lactate, generating NADH.

10. A typical slow-twitch muscle fibre that took 100 milliseconds (ms) to complete one contraction was compared to a fast-twitch muscle fibre that took 75 ms.

Calculate how many more times a fast-twitch muscle fibre can contract in one minute compared to a slow-twitch muscle fibre.

(1000 ms = 1 second)

- A 25
- B 200
- C 800
- D 1500

11. A sample of muscle fibres from the thigh of an Olympic sprinter was analysed and compared to a sample from an elite long-distance runner.

Which row in the table shows the expected results?

	Myoglobin concentration	Glycogen concentration	Number of mitochondria
A	lower	higher	lower
B	higher	lower	higher
C	lower	higher	higher
D	higher	lower	lower

[Turn over

12. The graph shows the changes in the average sperm count of males in a country.

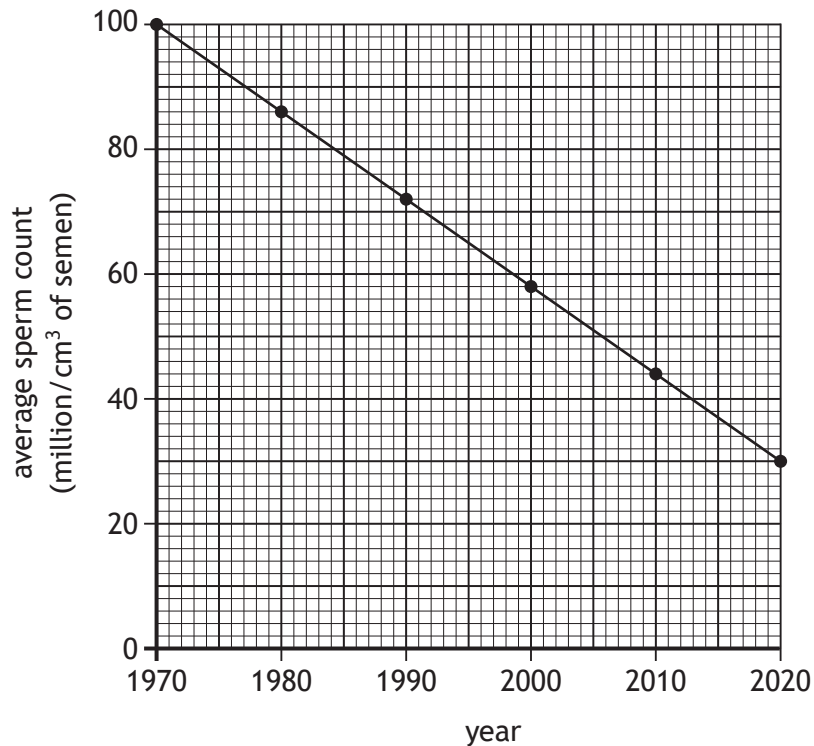

Which of the following statements is correct?

- A The average sperm count decreased by 14% between 1980 and 1990.
- B The average sperm count decreased by 60 million/cm³ between 1970 and 2010.
- C The average sperm count will be 16 million/cm³ in 2025 if the current trend continues.
- D The average sperm count has decreased by 1.4 million/cm³/year between 1970 and 2020.

13. A study was carried out to investigate the effects of different fertility drugs on sperm count. 12 000 males participated and they were randomly split into three groups of 4000.

Each group was given a different fertility drug.

It was discovered that many participants had also taken additional fertility supplements during the study.

From the information given, it was expected that the study would be

- A valid and reliable
- B valid but not reliable
- C not valid but reliable
- D not valid and not reliable.

14. Which row in the table identifies a type of routine ultrasound scan and the stage in pregnancy when it is normally carried out?

	Scan	Stage in pregnancy (weeks)
A	anomaly	8–14
B	dating	14–18
C	anomaly	18–20
D	dating	18–20

15. The diagram shows the inheritance of sickle cell in three generations of a family.

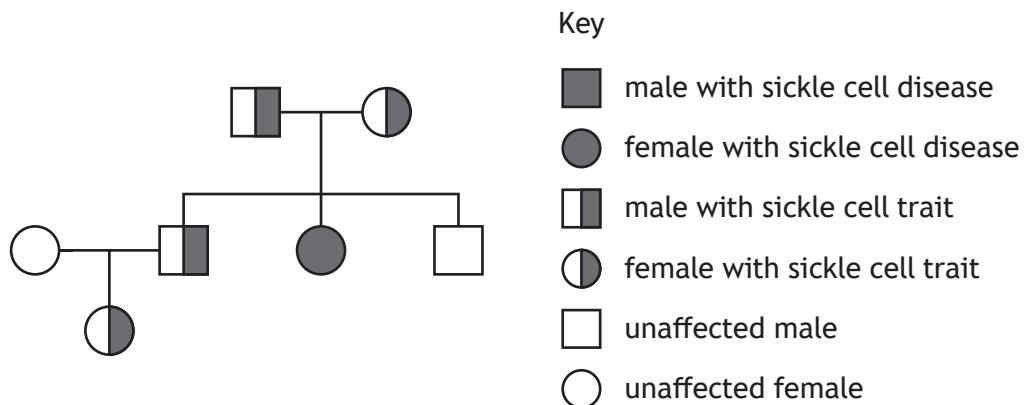

Identify the type of inheritance for sickle cell.

- A Autosomal recessive
- B Sex-linked recessive
- C Autosomal dominant
- D Incomplete dominance

[Turn over

16. The diagram shows a blood capillary, tissue cells and a lymphatic vessel.

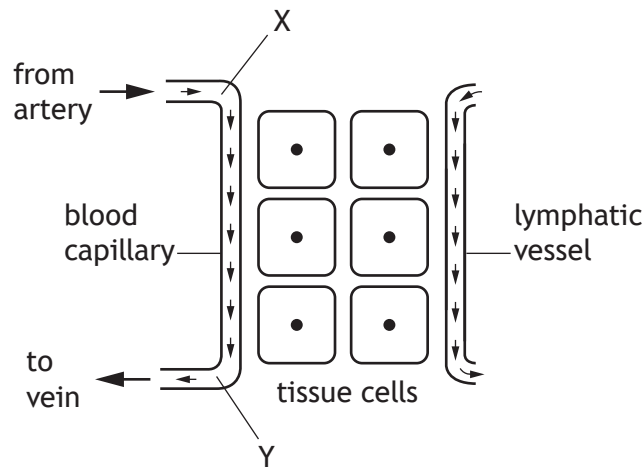

Which of the following statements explains the difference in blood pressure between points X and Y?

- A Blood pressure is higher at Y than X as plasma enters the blood between X and Y.
- B Blood pressure is higher at X than Y as plasma leaves the blood between X and Y.
- C Blood pressure is lower at X than Y as tissue fluid leaves the blood between X and Y.
- D Blood pressure is lower at Y than X as lymph enters the blood between X and Y.

17. The diagram shows some stages that occur during the control of blood glucose levels. Identify the stage that may **not** occur in an individual with type 2 diabetes.

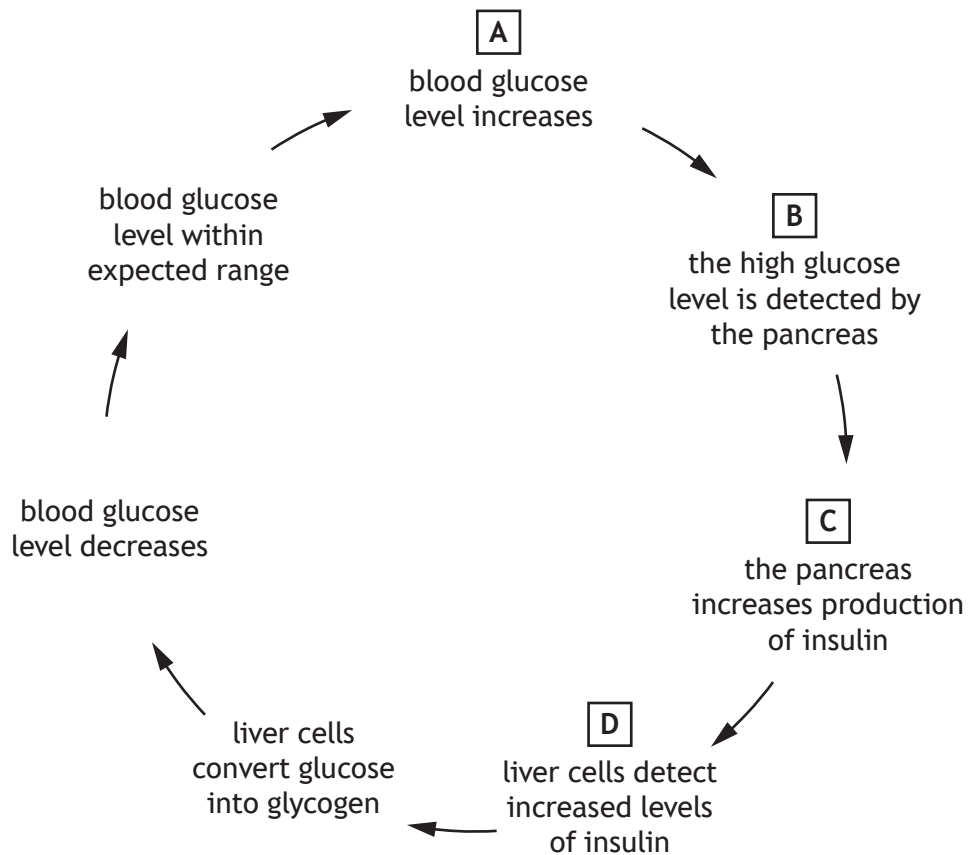

18. The diagram shows the direction of impulse transmission through a hand when the fingers are being used to type on a keyboard.

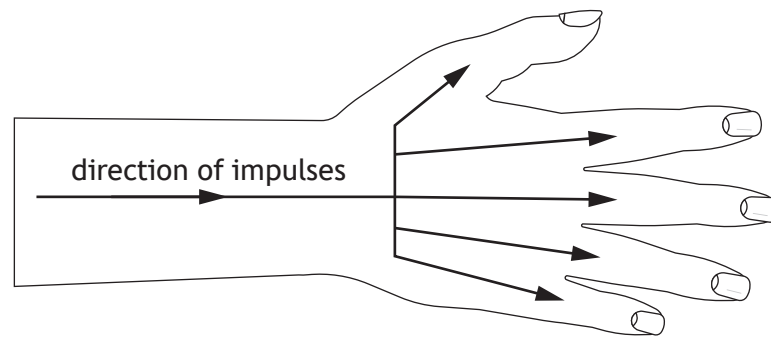

The fine motor control of the fingers occurs because of

- A summation of weak stimuli
 - B diverging neural pathways
 - C converging neural pathways
 - D reverberating neural pathways.
19. The table shows the number of individuals of different age groups diagnosed with dementia in a country over 4 years.

		Number of individuals diagnosed with dementia		
Age group		51–65	66–80	Over 80
Year				
2016		4421	5210	3256
2017		4821	4925	3111
2018		5012	5222	2965
2019		5123	5600	2709

Which of the following statements is correct?

- A The total number of individuals diagnosed with dementia increased every year.
- B More individuals were diagnosed with dementia in 2016 than in any other year.
- C More individuals aged 51–80 were diagnosed with dementia in 2019 compared to 2016.
- D More individuals were diagnosed with dementia between the ages of 51–65 than other age categories.

[Turn over

20. The table shows the concentration of a drug measured in the blood of an individual every hour for 4 hours after the drug was taken.

Time since taken (hours)	Concentration of drug in blood (mg/L)
0	36
1	34
2	30
3	24
4	16

Predict the concentration of the drug remaining in the blood at 5 hours.

- A 6
 - B 8
 - C 10
 - D 16
21. The role of mast cells is to
- A engulf pathogens
 - B release histamine
 - C produce antibodies
 - D cause vasoconstriction.

22. An individual's white blood cell count was measured during the course of an infection. Initially the white blood cell count was within the normal range of 5000–10 000 cells/mm³. Two days later it had increased to 15 000 cells/mm³. After four days it fell to 3000 cells/mm³ before gradually increasing to within the normal range over the next six days.

Which graph shows these changes in the individual's white blood cell count?

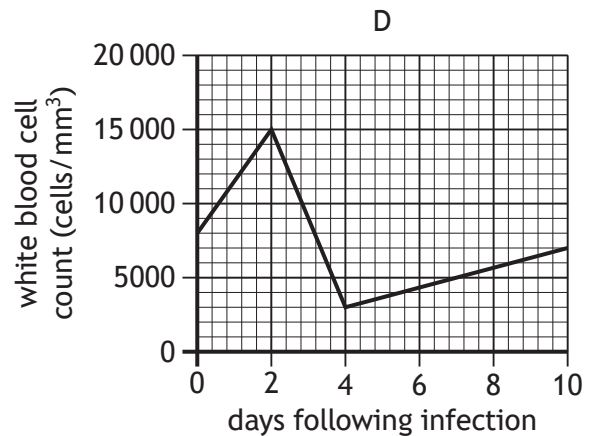
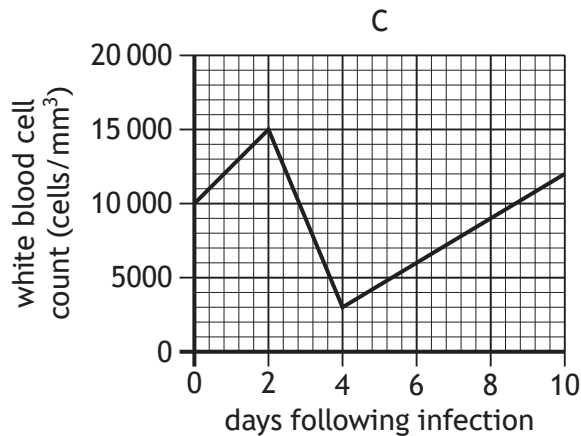
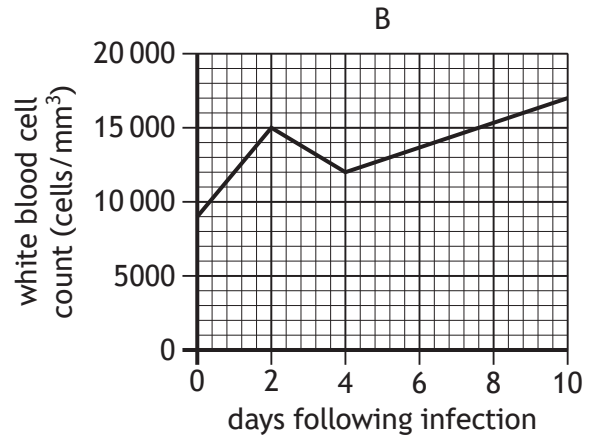
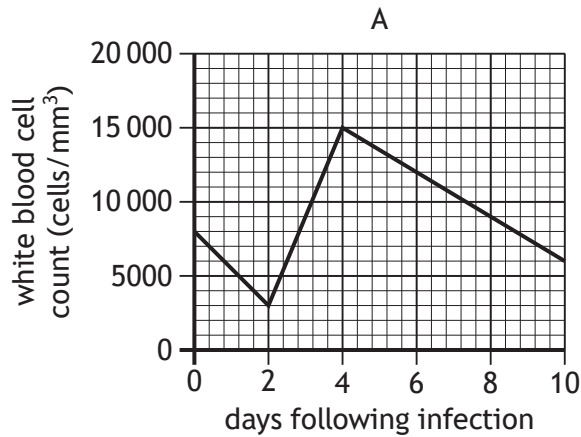

[Turn over

23. The graph shows concentrations of T lymphocytes and HIV in the blood of an individual following infection with HIV.

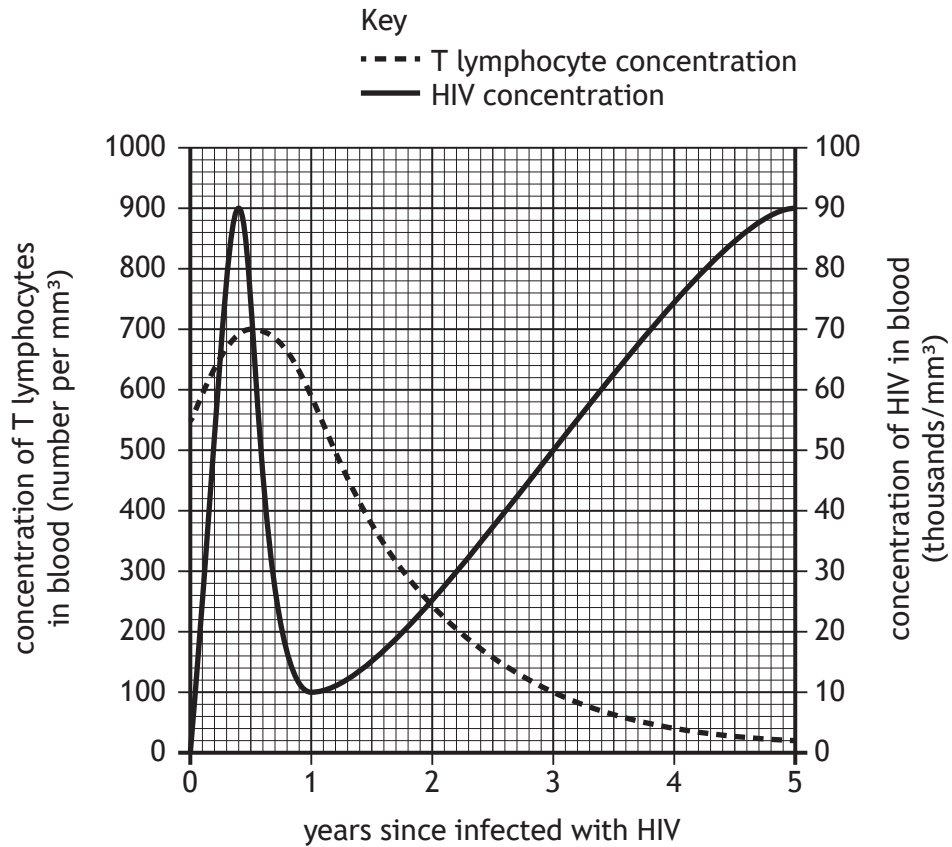

Which row in the table shows the concentration of T lymphocytes and HIV in the blood of the individual, three years since they were infected with HIV?

	Concentration of T lymphocytes in blood (number per mm ³)	Concentration of HIV in blood (thousands/mm ³)
A	100	50
B	500	10
C	100	500
D	10	50

24. A patient was found to have a white blood cell count of 7000 cells/cm³ of blood.

The ratio of phagocytes to lymphocytes was 7:3.

Which row in the table shows the number of phagocytes and lymphocytes in a 10 cm³ sample of this patient's blood?

	Phagocytes	Lymphocytes
A	4900	2100
B	2100	4900
C	49 000	21 000
D	21 000	49 000

25. Influenza is a public health problem every winter.

This is due to changes that occur in the

- A antigens of the virus
- B vaccine given to patients
- C antibodies produced by the body
- D memory cells present in the blood.

[END OF QUESTION PAPER]

SPACE FOR ROUGH WORK

SPACE FOR ROUGH WORK

[BLANK PAGE]

DO NOT WRITE ON THIS PAGE

FOR OFFICIAL USE



--	--	--	--	--	--

National
Qualifications
2025

Mark

--

X840/76/01

**Human Biology
Paper 2**

TUESDAY, 27 MAY
10:10 AM – 12:30 PM



Fill in these boxes and read what is printed below.

Full name of centre

--

Town

--

Forename(s)

--

Surname

--

Number of seat

--

Date of birth

Day

--	--

Month

--	--

Year

--	--

Scottish candidate number

--	--	--	--	--	--	--	--	--	--

Total marks — 95

Attempt ALL questions.

You may use a calculator.

Question 15 contains a choice.

Write your answers clearly in the spaces provided in this booklet. Additional space for answers and rough work is provided at the end of this booklet. If you use this space you must clearly identify the question number you are attempting. Any rough work must be written in this booklet. Score through your rough work when you have written your final copy.

Use **blue** or **black** ink.

Before leaving the examination room you must give this booklet to the Invigilator; if you do not, you may lose all the marks for this paper.



Total marks — 95
 Attempt ALL questions
 Question 15 contains a choice

1. The diagram shows a somatic stem cell dividing.

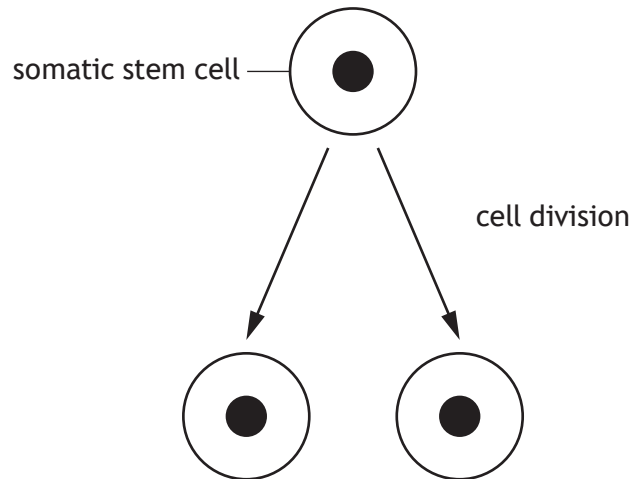

(a) (i) Name the type of cell division shown in the diagram.

1

(ii) Germline stem cells undergo a different type of cell division to produce gametes.

State one location of the production of gametes.

1

(b) Somatic stem cells can be found in the cornea of the eye.

Describe how these stem cells could differentiate into specialised cells such as corneal cells.

1



1. (continued)

- (c) Some conditions can cause severe damage to the cornea and somatic stem cells found in the eye. Stem cell transplants can be carried out to replace the damaged somatic stem cells with healthy stem cells.

The table shows the number of stem cell donors and the number of stem cell transplant recipients in one year.

Age group (years)	Number of stem cell donors	Number of stem cell transplant recipients
0–17	5	30
18–34	24	290
35–49	88	330
50–59	192	373
60–69	384	590
70–79	700	1021
80–99	394	656

- (i) Use data from the table to describe the changes that occur in the number of stem cell donors as age increases from 0 to 99 years.

2

- (ii) Using information in the table, suggest a benefit of using a patient's own stem cells for this treatment.

1

- (d) Corneal repair is a therapeutic use of stem cells.
Describe one use of stem cells in research.

1



2. The polymerase chain reaction (PCR) is used to amplify DNA.
The diagram shows a primer attached to a single strand of DNA.



- | | |
|---|---|
| <p>(a) Name base 3.</p> <p>_____</p> | 1 |
| <p>(b) PCR requires two primers.
Explain why the two primers have different base sequences.</p> <p>_____</p> <p>_____</p> <p>_____</p> <p>_____</p> | 2 |
| <p>(c) State a temperature used to allow primers to bind during PCR.</p> <p>_____ °C</p> | 1 |



3. A chromosome mutation on the X chromosome can result in the blood clotting disorder haemophilia A.

The diagram shows two chromosomes from an individual with haemophilia A.

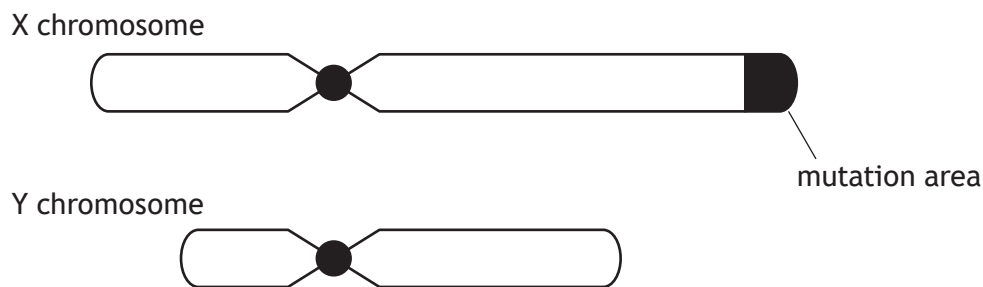

(a) (i) Name the type of inheritance for haemophilia A.

1

(ii) In a population, 6300 males have haemophilia A. This represents 75% of the total number of individuals with this condition.

Calculate how many females have haemophilia A in this population.

1

Space for calculation

[Turn over



3. (continued)

- (b) The diagram shows the order of exons in the mutation area of the X chromosome from an individual with haemophilia A and an individual without haemophilia A.

with haemophilia A

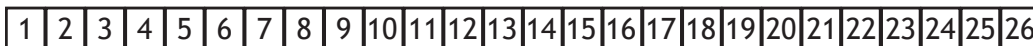
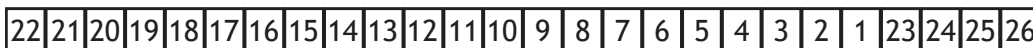

without haemophilia A

- (i) Name the type of chromosome mutation that causes haemophilia A. 1
- _____
- (ii) State the function of an exon. 1
- _____
- (iii) During the expression of a gene for a blood clotting protein, mRNA is transcribed from exons 1 to 26. 2
- Explain why this protein is non-functional in individuals with haemophilia A.
- _____
- _____
- _____
- (c) Describe how alternative RNA splicing leads to different proteins being expressed from one gene. 1
- _____
- _____



4. The diagram shows a mitochondrion and a magnified area.
Some of the reactions involved in an electron transport chain are shown in the magnified area.

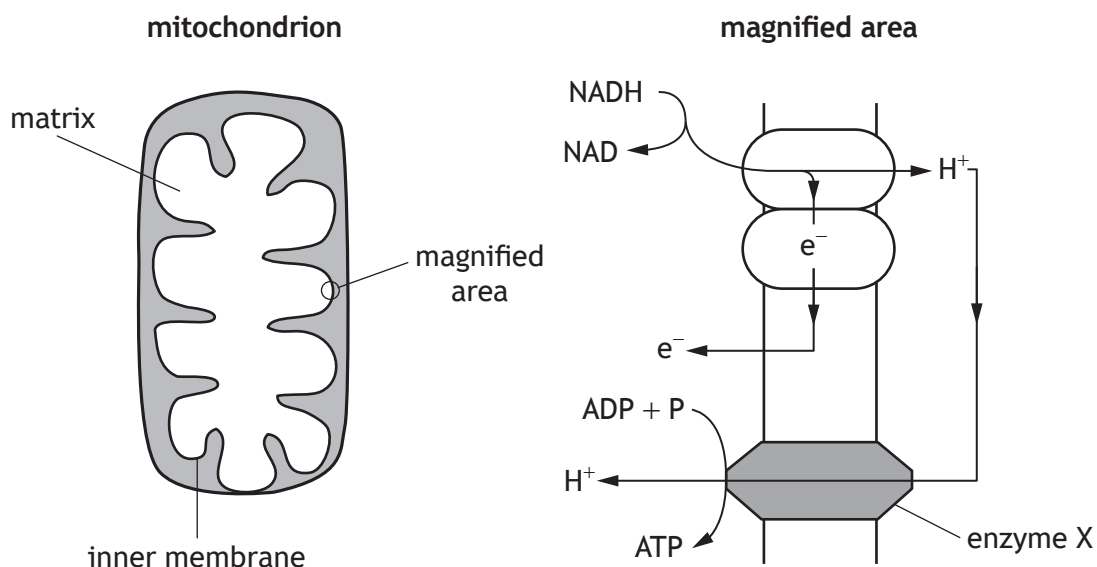

- (a) Use the mitochondrion diagram to describe how the inner membrane is adapted to maximise ATP production. 1
- _____
- _____
- (b) NADH is formed in the matrix of the mitochondrion.
State another location in the cell where NADH is formed. 1
- _____
- (c) Describe one role of electrons (e⁻) in the electron transport chain. 1
- _____
- _____
- (d) Name enzyme X. 1
- _____

[Turn over



5. An investigation was carried out into the effect of substrate concentration on the inhibition of catalase by copper nitrate. Catalase breaks down hydrogen peroxide into water and oxygen.

10 cm³ of catalase solution was mixed with 10 cm³ copper nitrate solution and a paper disc was placed in this solution for 10 seconds.

The disc was then dropped into hydrogen peroxide. When the disc reached the bottom of the beaker, a timer was started and the time taken for the disc to float to the surface was recorded. Oxygen produced during the reaction caused the paper disc to float.

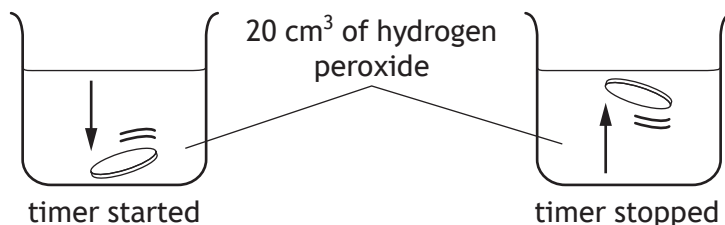

This was repeated using different concentrations of hydrogen peroxide.

A control experiment was carried out where copper nitrate solution was replaced with water.

The results are shown in the table.

Concentration of hydrogen peroxide (%)	Time for disc to float to surface (seconds)	
	Catalase + copper nitrate solution	Catalase solution
0.5	192	120
1.0	136	84
2.0	72	36
3.0	52	28
5.0	28	28

- (a) Name the type of metabolic reaction catalysed by catalase. 1

- (b) (i) State two variables, not already mentioned, that should be controlled to make the investigation valid. 2

1. _____

2. _____

- (ii) State the purpose of the control in **this** investigation. 1



5. (continued)

MARKS DO NOT WRITE IN THIS MARGIN

- (c) On the grid, complete the line graph to show the results of the investigation using catalase and copper nitrate.

2

(Additional graph paper, if required, can be found on page 28.)

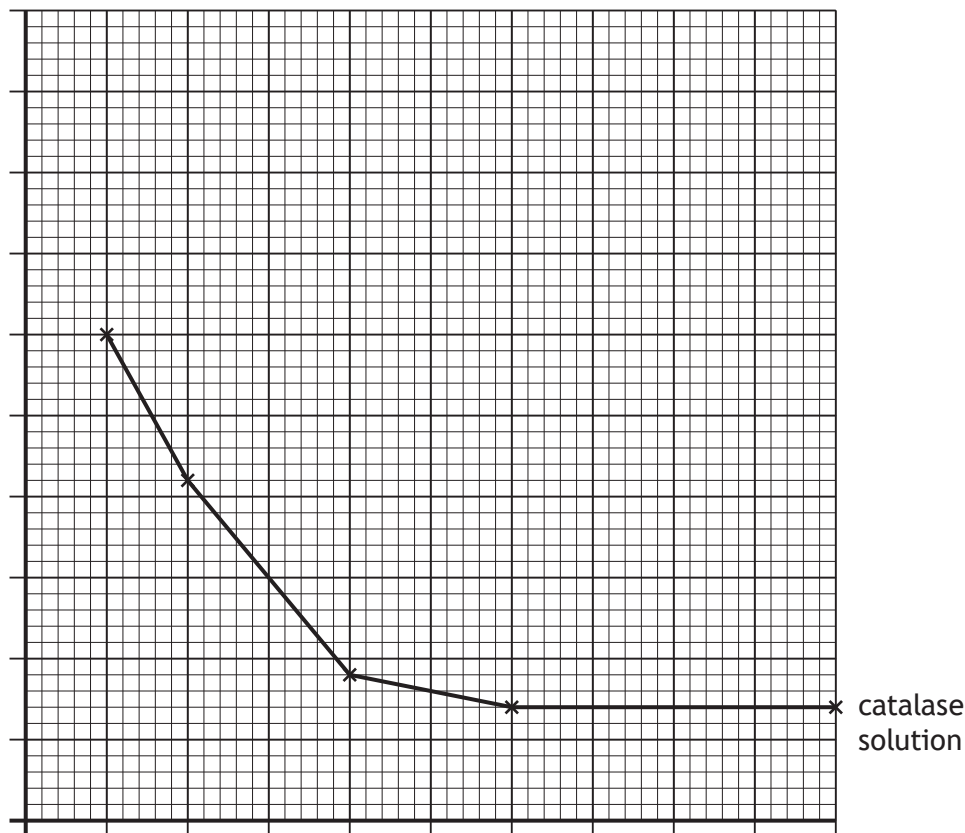

- (d) State the conclusion that can be made from these results.

1

- (e) Another disc was placed in the solution of catalase and copper nitrate then dropped into a beaker of 6.0% hydrogen peroxide.

Predict the average time for the disc to float to the surface.

1

_____ seconds

[Turn over



6. A study was carried out to determine if the physical activity and body mass of females affects fertility.

The results are shown in the table.

Physical activity category	Body mass category	Chance of fertility problems (%)
Low	healthy	14
	overweight	17
	obese	27
Moderate	healthy	13
	overweight	16
	obese	18
High	healthy	11
	overweight	15
	obese	17

- (a) State the physical activity and body mass category that resulted in the greatest chance of fertility problems in females.

1

- (b) (i) BMI is used to determine body mass category.

Calculate the BMI of a female with a body mass of 77 kg and a height of 1.7 m.

1

Space for calculation

- (ii) A female has a moderate level of physical activity and a BMI of 33.

State the chance that this female will have fertility problems.

1

_____ %



* X 8 4 0 7 6 0 1 1 0 *

6. (b) (continued)

(iii) The female and her partner are undergoing treatment for infertility because the partner has a low sperm count.

Name and describe a suitable treatment for this couple.

2

Treatment _____

Description _____

[Turn over



* X 8 4 0 7 6 0 1 1 1 *

7. The diagram shows a section through a human heart.

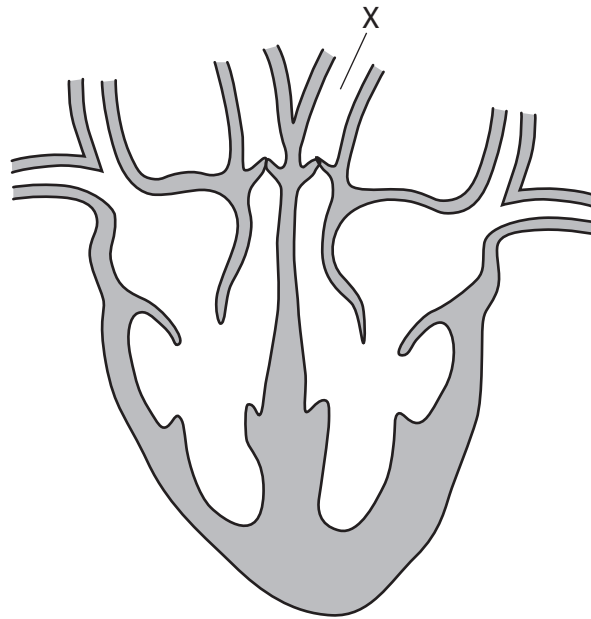

(a) (i) Name blood vessel X.

1

(ii) Describe the evidence shown in the diagram that suggests the heart is in atrial systole.

1

(b) Describe how impulses from the sino-atrial node (SAN) cause ventricular systole.

2



7. (continued)

- (c) The diagrams show ECG traces from an individual before and after strenuous exercise.

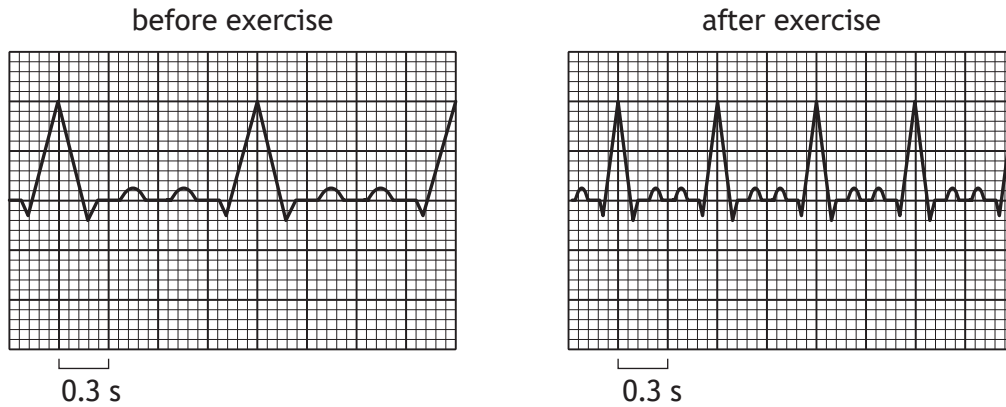

Calculate the increase in heart rate during exercise.

1

Space for calculation

_____ beats per minute

- (d) Describe how the medulla lowers the heart rate following a period of exercise.

2

[Turn over



8. When an atheroma develops in an artery it can be treated by inserting a mesh tube called a stent.
The diagrams show an artery before and after a stent has been inserted.

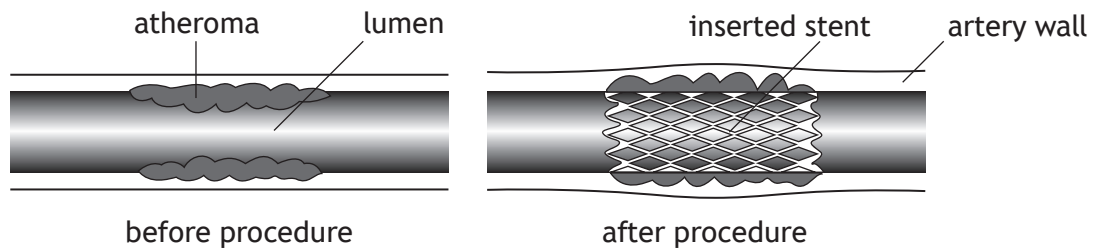

- (a) (i) Describe the formation of an atheroma within an artery. 2

- (ii) Use the diagrams to suggest how the insertion of a stent leads to increased blood flow in an artery. 1

- (b) A ruptured atheroma in an artery may lead to thrombosis.
Describe how thrombosis can cause a myocardial infarction (heart attack). 2



8. (continued)

(c) The graph shows deaths from coronary heart disease in four countries.

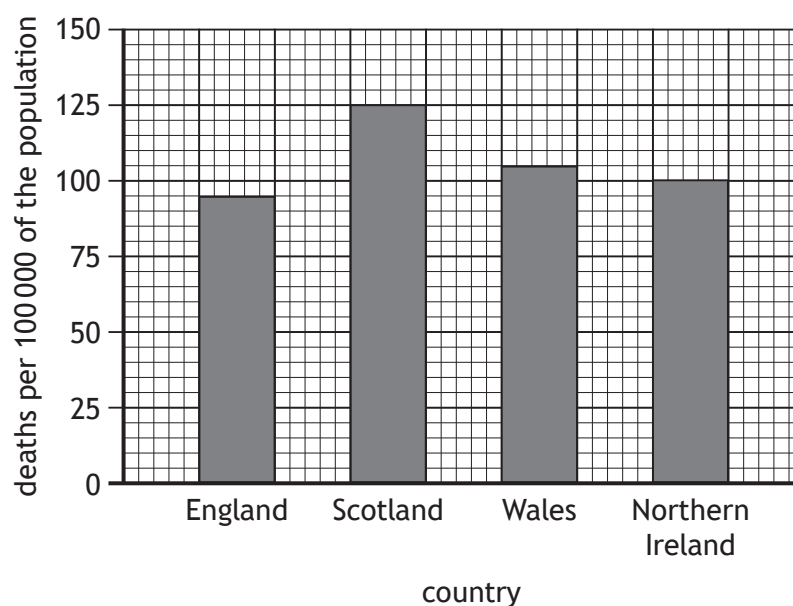

(i) Using data from the graph, the risk of an individual dying from coronary heart disease in Northern Ireland was calculated to be 1 in 1000.

Use data from the graph to calculate the risk of an individual dying from coronary heart disease in Scotland.

Space for calculation

1 in _____

(ii) Explain why deaths from coronary heart disease are expressed as per 100 000 of the population.

[Turn over



9. High density lipoproteins (HDLs) and low density lipoproteins (LDLs) transport cholesterol around the body.

(a) (i) State a use of cholesterol in the body.

1

(ii) Name the organ to which HDL transports excess cholesterol for elimination.

1

(b) Familial hypercholesterolaemia (FH) is an inherited condition.

Individuals with FH have high levels of LDLs in their bloodstream.

(i) Statins are drugs, and can be prescribed to individuals with FH.

Statins act as competitive inhibitors of an enzyme involved in the synthesis of cholesterol.

Describe the mode of action of competitive inhibitors such as statins.

1

(ii) FH is caused by an autosomal dominant allele.

Describe two ways in which the patterns of inheritance in a family history would indicate autosomal dominance.

2

1. _____

2. _____



* X 8 4 0 7 6 0 1 1 6 *

10. The diagram shows divisions of the nervous system.

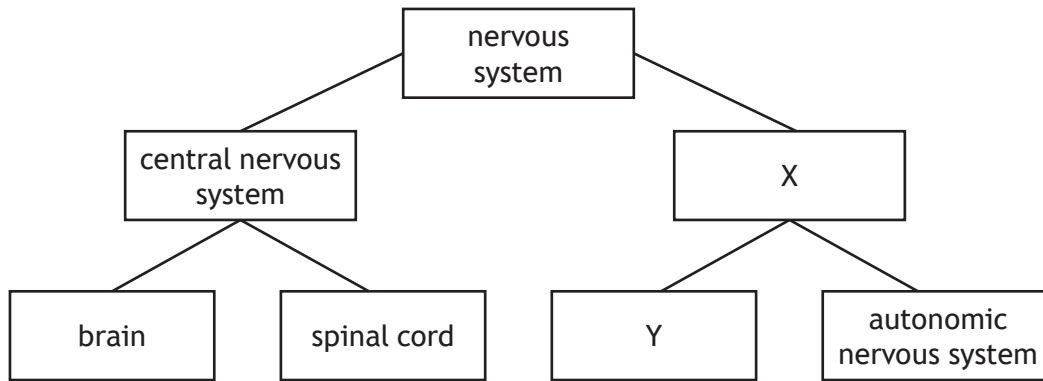

(a) Identify X and Y.

2

X _____ Y _____

(b) The diagram represents a neuron and its junction with skeletal muscle tissue.

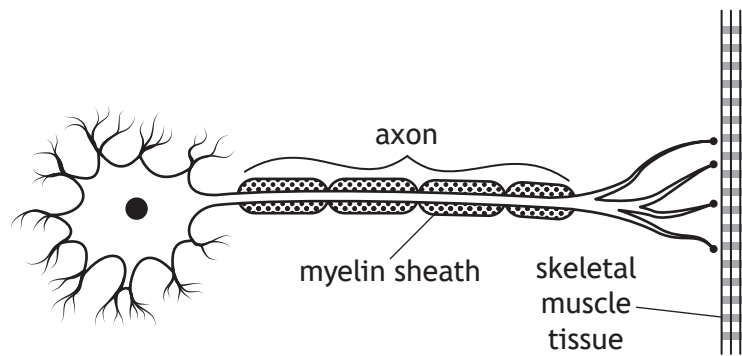

Name the type of neuron shown in the diagram.

1

(c) Describe myelination and its importance in child development.

3



11. The diagram represents a flow of information through memory.

MARKS DO NOT WRITE IN THIS MARGIN

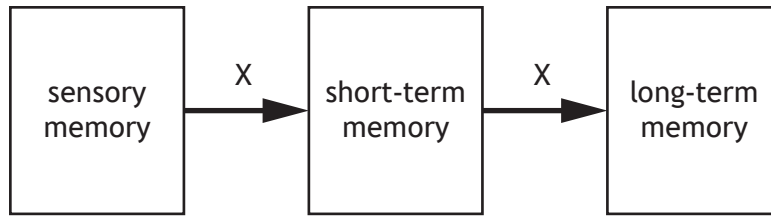

(a) (i) Name process X. 1

(ii) Name two methods that enable the transfer of information from short-term to long-term memory. 2

1. _____

2. _____

(b) State the location in the brain where memories are stored. 1

(c) An investigation into the serial position effect on recall was carried out. A list of words was read out to a group of students. Each student then wrote down the words that they could recall.

The table shows the position of the words in the list and the number of students who recalled each word.

Position of word in list	Number of students who recalled each word
1	18
2	17
3	16
4	14
5	10
6	8
7	7
8	8
9	16
10	17



11. (c) (continued)

- (i) It was observed that more students recalled the words at the start and the end of the list compared to those in the middle.

Explain this observation.

2

- (ii) The investigation was evaluated as being unreliable.

State how the investigation could be made reliable.

1

[Turn over



* X 8 4 0 7 6 0 1 1 9 *

12. Dopamine is a neurotransmitter that activates the reward pathway in the brain.

(a) State one effect of activating the reward pathway. 1

(b) State one method of removal of dopamine from a synapse. 1

(c) (i) A dopamine agonist can be used in the treatment of Parkinson's disease. State the effect of prolonged use of an agonist. 1

(ii) In a clinical trial of a potential new drug for the treatment of Parkinson's disease, individuals were divided into groups in a randomised way. Name one other protocol that could be used during this clinical trial and explain its importance to the results. 2

Protocol _____

Importance _____

(iii) State one other design factor that would allow the results of the clinical trial to have statistical significance. 1



13. The diagram represents lymphocyte responses to infection by a pathogen.

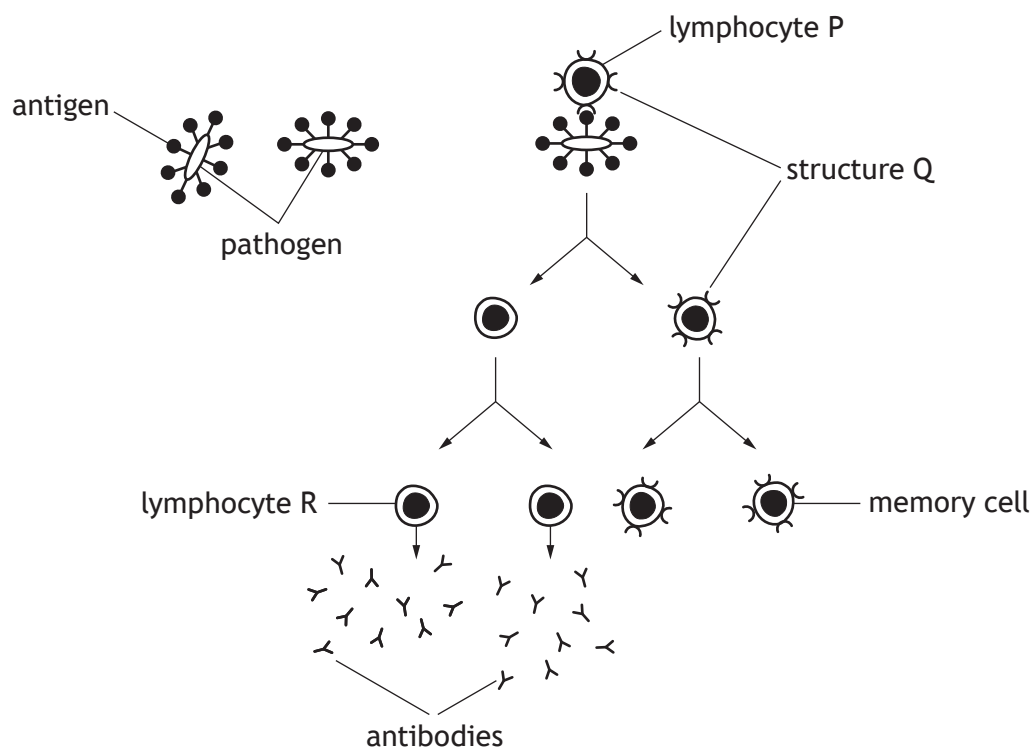

- (a) (i) Structure Q is found on the surface of lymphocytes to allow them to bind with antigens.

Name structure Q.

1

- (ii) Give evidence from the diagram that shows lymphocyte R is a B lymphocyte.

1

- (b) Antibodies attach to and inactivate a pathogen, so the pathogen cannot spread through the body.

Describe the role of phagocytes following the inactivation of the pathogen.

1

[Turn over



* X 8 4 0 7 6 0 1 2 1 *

13. (continued)

- (c) An individual contracted chicken pox during childhood. A few years later they were exposed to the same chicken pox antigen.

Describe the role of memory cells in protecting this individual from developing symptoms of chicken pox during this second exposure.

2

- (d) T lymphocytes are another type of lymphocyte that protect the body from infection.

Explain how T lymphocytes destroy infected cells.

1



[Turn over for next question

DO NOT WRITE ON THIS PAGE



* X 8 4 0 7 6 0 1 2 3 *

14. Polio is a viral disease that has been eradicated in most countries due to mass vaccination programmes.

The graph shows changes in the global number of polio cases and the percentage of the world population vaccinated between 1980 and 2015.

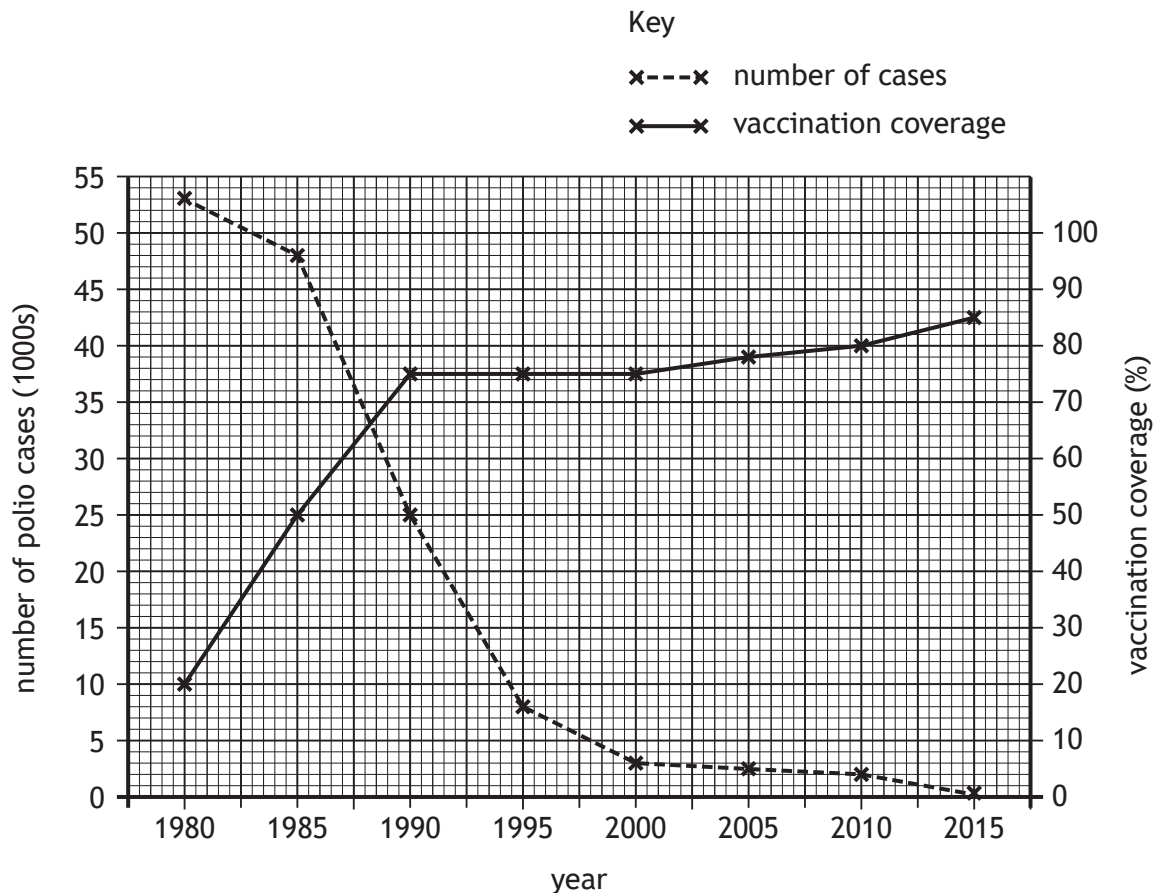

(a) (i) State the vaccination coverage achieved when the number of polio cases was 8000.

_____ %

1

(ii) Calculate the percentage decrease in polio cases in the 30-year period from 1980 to 2010.

Space for calculation

1

_____ %



* X 8 4 0 7 6 0 1 2 4 *

14. (a) (continued)

MARKS DO NOT WRITE IN THIS MARGIN

(iii) Use data from the graph to describe the changes in vaccination coverage between 1980 and 2000.

2

(b) Polio is still present in some developing countries.

The table shows the number of polio cases in one of these countries between 2000 and 2010.

Year	2000	2002	2004	2006	2008	2010
Number of polio cases	90	50	20	15	10	15

(i) Using data in the table and graph, calculate the simple whole number ratio of the global number of cases of polio to the number of cases in this country in 2000.

1

Space for calculation

_____ : _____
global country

(ii) In order to establish herd immunity for polio, there has to be at least 85% vaccination coverage.

If the population of this country is 2 million people, calculate the number of individuals that must be vaccinated to establish herd immunity for polio in this country.

1

Space for calculation

(iii) Suggest why the herd immunity threshold may not be reached in this developing country despite a 10-year mass vaccination programme.

1



15. Attempt either A or B.

Write your answer in the space below and on *page 27*.

A Write notes on the follicular and luteal phases of the menstrual cycle.

9

OR

B Write notes on the biology of controlling fertility and the methods of contraception.

9

You may use labelled diagrams where appropriate.



* X 8 4 0 7 6 0 1 2 6 *

MARKS DO NOT
WRITE IN
THIS
MARGIN

ADDITIONAL SPACE FOR ANSWER to question 15

[END OF QUESTION PAPER]



* X 8 4 0 7 6 0 1 2 7 *

ADDITIONAL SPACE FOR ANSWERS AND ROUGH WORK

Additional graph paper for question 5 (c)

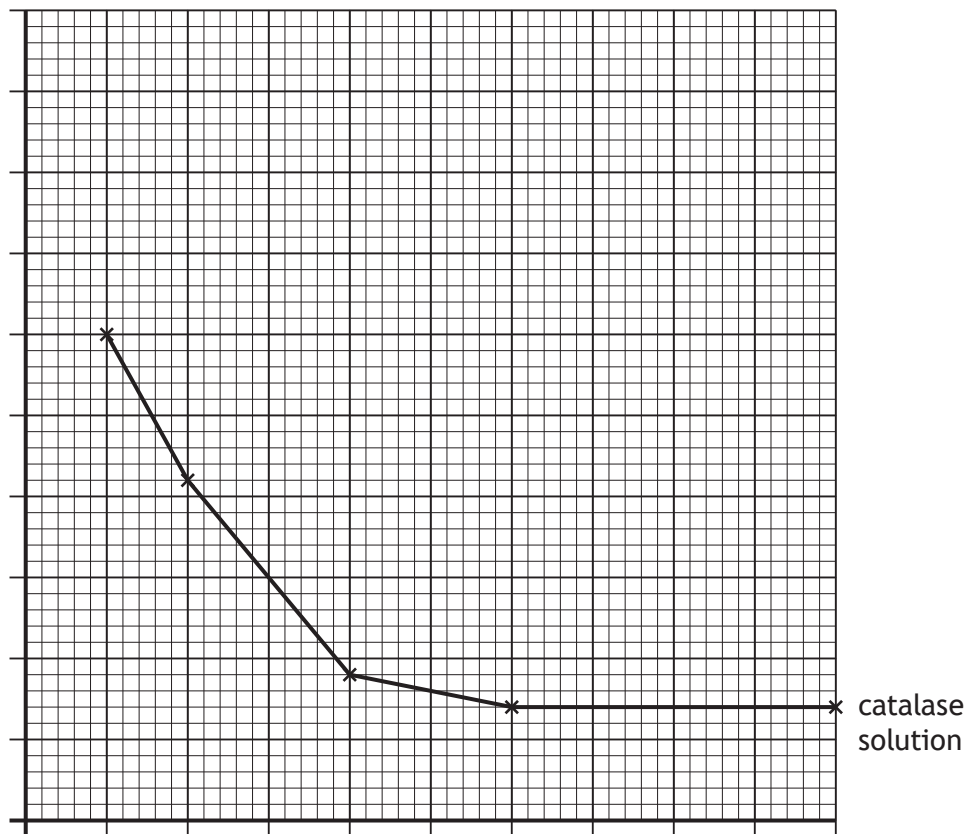

MARKS DO NOT
WRITE IN
THIS
MARGIN

ADDITIONAL SPACE FOR ANSWERS AND ROUGH WORK



* X 8 4 0 7 6 0 1 2 9 *

MARKS DO NOT
WRITE IN
THIS
MARGIN

ADDITIONAL SPACE FOR ANSWERS AND ROUGH WORK



* X 8 4 0 7 6 0 1 3 0 *

[BLANK PAGE]

DO NOT WRITE ON THIS PAGE



* X 8 4 0 7 6 0 1 3 1 *

[BLANK PAGE]

DO NOT WRITE ON THIS PAGE



* X 8 4 0 7 6 0 1 3 2 *