



National  
Qualifications  
2016

**X757/76/02**

**Physics**  
**Section 1 — Questions**

TUESDAY, 24 MAY  
9:00 AM – 11:30 AM

Instructions for the completion of Section 1 are given on *Page 02* of your question and answer booklet X757/76/01.

Record your answers on the answer grid on *Page 03* of your question and answer booklet.

Reference may be made to the Data Sheet on *Page 02* of this booklet and to the Relationships Sheet X757/76/11.

Before leaving the examination room you must give your question and answer booklet to the Invigilator; if you do not, you may lose all the marks for this paper.



\* X 7 5 7 7 6 0 2 \*

## DATA SHEET

### COMMON PHYSICAL QUANTITIES

Quantity	Symbol	Value	Quantity	Symbol	Value
Speed of light in vacuum	$c$	$3.00 \times 10^8 \text{ m s}^{-1}$	Planck's constant	$h$	$6.63 \times 10^{-34} \text{ J s}$
Magnitude of the charge on an electron	$e$	$1.60 \times 10^{-19} \text{ C}$	Mass of electron	$m_e$	$9.11 \times 10^{-31} \text{ kg}$
Universal Constant of Gravitation	$G$	$6.67 \times 10^{-11} \text{ m}^3 \text{ kg}^{-1} \text{ s}^{-2}$	Mass of neutron	$m_n$	$1.675 \times 10^{-27} \text{ kg}$
Gravitational acceleration on Earth	$g$	$9.8 \text{ m s}^{-2}$	Mass of proton	$m_p$	$1.673 \times 10^{-27} \text{ kg}$
Hubble's constant	$H_0$	$2.3 \times 10^{-18} \text{ s}^{-1}$			

### REFRACTIVE INDICES

The refractive indices refer to sodium light of wavelength 589 nm and to substances at a temperature of 273 K.

Substance	Refractive index	Substance	Refractive index
Diamond	2.42	Water	1.33
Crown glass	1.50	Air	1.00

### SPECTRAL LINES

Element	Wavelength/nm	Colour	Element	Wavelength/nm	Colour
Hydrogen	656	Red	Cadmium	644	Red
	486	Blue-green		509	Green
	434	Blue-violet		480	Blue
	410	Violet	Lasers		
	397	Ultraviolet	<i>Element</i>	<i>Wavelength/nm</i>	<i>Colour</i>
	389	Ultraviolet	Carbon dioxide	9550 } 10590 }	Infrared
Sodium	589	Yellow	Helium-neon	633	Red

### PROPERTIES OF SELECTED MATERIALS

Substance	Density/kg m <sup>-3</sup>	Melting Point/K	Boiling Point/K
Aluminium	$2.70 \times 10^3$	933	2623
Copper	$8.96 \times 10^3$	1357	2853
Ice	$9.20 \times 10^2$	273	....
Sea Water	$1.02 \times 10^3$	264	377
Water	$1.00 \times 10^3$	273	373
Air	1.29	....	....
Hydrogen	$9.0 \times 10^{-2}$	14	20

The gas densities refer to a temperature of 273 K and a pressure of  $1.01 \times 10^5 \text{ Pa}$ .

SECTION 1 — 20 marks

Attempt ALL questions

1. A car accelerates uniformly from rest. The car travels a distance of 60 m in 6.0 s. The acceleration of the car is

- A  $0.83 \text{ m s}^{-2}$
- B  $3.3 \text{ m s}^{-2}$
- C  $5.0 \text{ m s}^{-2}$
- D  $10 \text{ m s}^{-2}$
- E  $20 \text{ m s}^{-2}$ .

2. A ball is thrown vertically upwards and falls back to Earth.

Neglecting air resistance, which velocity-time graph represents its motion?

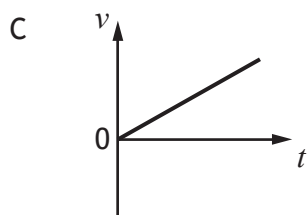
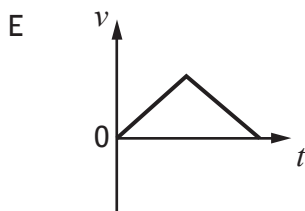
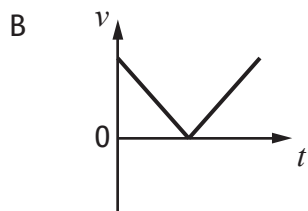
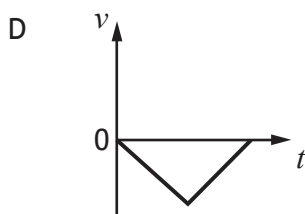
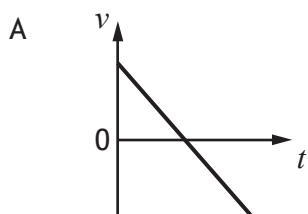

[Turn over

3. A block of wood slides with a constant velocity down a slope. The slope makes an angle of  $30^\circ$  with the horizontal as shown. The mass of the block is  $2.0 \text{ kg}$ .

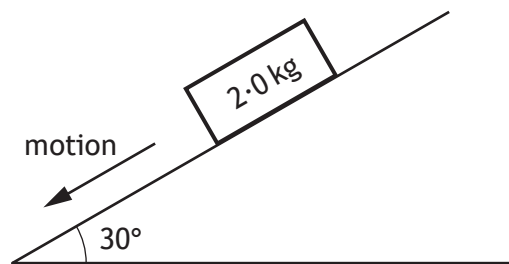

The magnitude of the force of friction acting on the block is

- A  $1.0 \text{ N}$
  - B  $1.7 \text{ N}$
  - C  $9.8 \text{ N}$
  - D  $17.0 \text{ N}$
  - E  $19.6 \text{ N}$ .
4. The graph shows the force which acts on an object over a time interval of  $8.0$  seconds.

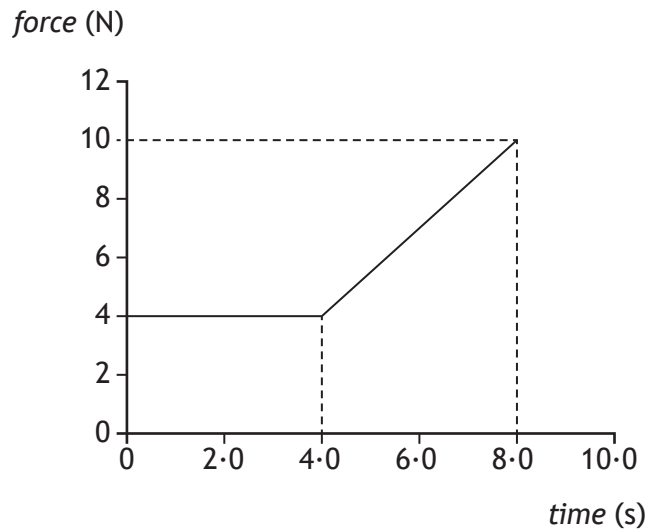

The momentum gained by the object during this  $8.0$  seconds is

- A  $12 \text{ kg m s}^{-1}$
- B  $32 \text{ kg m s}^{-1}$
- C  $44 \text{ kg m s}^{-1}$
- D  $52 \text{ kg m s}^{-1}$
- E  $72 \text{ kg m s}^{-1}$ .

5. A planet orbits a star at a distance of  $3.0 \times 10^9$  m.  
The star exerts a gravitational force of  $1.6 \times 10^{27}$  N on the planet.  
The mass of the star is  $6.0 \times 10^{30}$  kg.  
The mass of the planet is
- A  $2.4 \times 10^{14}$  kg
  - B  $1.2 \times 10^{16}$  kg
  - C  $3.6 \times 10^{25}$  kg
  - D  $1.6 \times 10^{26}$  kg
  - E  $2.4 \times 10^{37}$  kg.
6. A car horn emits a sound with a constant frequency of 405 Hz.  
The car is travelling away from a student at  $28.0 \text{ m s}^{-1}$ .  
The speed of sound in air is  $335 \text{ m s}^{-1}$ .  
The frequency of the sound from the horn heard by the student is
- A 371 Hz
  - B 374 Hz
  - C 405 Hz
  - D 439 Hz
  - E 442 Hz.

[Turn over

7. The graphs show how the radiation per unit surface area,  $R$ , varies with the wavelength,  $\lambda$ , of the emitted radiation for two stars, P and Q.

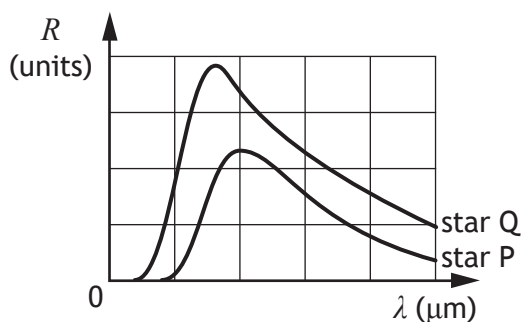

A student makes the following conclusions based on the information in the graph.

- I Star P is hotter than star Q.
- II Star P emits more radiation per unit surface area than star Q.
- III The peak intensity of the radiation from star Q is at a shorter wavelength than that from star P.

Which of these statements is/are correct?

- A I only
  - B II only
  - C III only
  - D I and II only
  - E II and III only
8. One type of hadron consists of two down quarks and one up quark.

The charge on a down quark is  $-\frac{1}{3}$ .

The charge on an up quark is  $+\frac{2}{3}$ .

Which row in the table shows the charge and type for this hadron?

	<i>charge</i>	<i>type of hadron</i>
A	0	baryon
B	+1	baryon
C	-1	meson
D	0	meson
E	+1	meson

9. A student makes the following statements about sub-nuclear particles.
- I The force mediating particles are bosons.
  - II Gluons are the mediating particles of the strong force.
  - III Photons are the mediating particles of the electromagnetic force.

Which of these statements is/are correct?

- A I only
  - B II only
  - C I and II only
  - D II and III only
  - E I, II and III
10. The last two changes in a radioactive decay series are shown below.  
A Bismuth nucleus emits a beta particle and its product, a Polonium nucleus, emits an alpha particle.

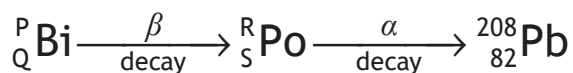

Which numbers are represented by P, Q, R and S?

	P	Q	R	S
A	210	83	208	81
B	210	83	210	84
C	211	85	207	86
D	212	83	212	84
E	212	85	212	84

[Turn over

11. The table below shows the threshold frequency of radiation for photoelectric emission for some metals.

<i>Metal</i>	<i>Threshold frequency (Hz)</i>
sodium	$4.4 \times 10^{14}$
potassium	$5.4 \times 10^{14}$
zinc	$6.9 \times 10^{14}$

Radiation of frequency  $6.3 \times 10^{14}$  Hz is incident on the surface of each of the metals.

Photoelectric emission occurs from

- A sodium only
  - B zinc only
  - C potassium only
  - D sodium and potassium only
  - E zinc and potassium only.
12. Radiation of frequency  $9.00 \times 10^{15}$  Hz is incident on a clean metal surface.
- The maximum kinetic energy of a photoelectron ejected from this surface is  $5.70 \times 10^{-18}$  J.
- The work function of the metal is
- A  $2.67 \times 10^{-19}$  J
  - B  $5.97 \times 10^{-18}$  J
  - C  $1.17 \times 10^{-17}$  J
  - D  $2.07 \times 10^{-2}$  J
  - E  $9.60 \times 10^{-1}$  J.

13. A ray of monochromatic light is incident on a grating as shown.

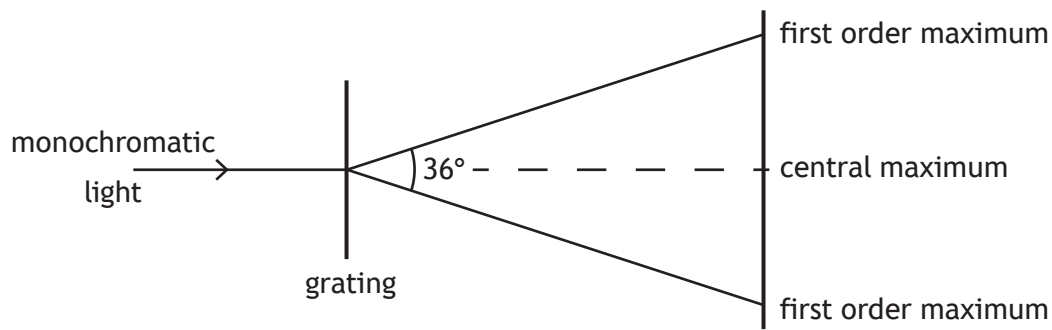

The wavelength of the light is 633 nm.

The separation of the slits on the grating is

- A  $1.96 \times 10^{-7}$  m  
 B  $1.08 \times 10^{-6}$  m  
 C  $2.05 \times 10^{-6}$  m  
 D  $2.15 \times 10^{-6}$  m  
 E  $4.10 \times 10^{-6}$  m.
14. Light travels from **glass** into **air**.  
 Which row in the table shows what happens to the speed, frequency and wavelength of the light as it travels from glass into air?

	<i>Speed</i>	<i>Frequency</i>	<i>Wavelength</i>
A	decreases	stays constant	decreases
B	decreases	increases	stays constant
C	stays constant	increases	increases
D	increases	increases	stays constant
E	increases	stays constant	increases

15. The irradiance of light from a point source is  $32 \text{ W m}^{-2}$  at a distance of 4.0 m from the source.  
 The irradiance of the light at a distance of 16 m from the source is
- A  $0.125 \text{ W m}^{-2}$   
 B  $0.50 \text{ W m}^{-2}$   
 C  $2.0 \text{ W m}^{-2}$   
 D  $8.0 \text{ W m}^{-2}$   
 E  $128 \text{ W m}^{-2}$ .

16. Part of the energy level diagram for an atom is shown

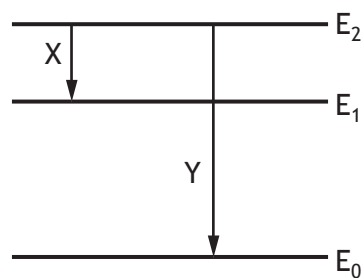

X and Y represent two possible electron transitions.

A student makes the following statements about transitions X and Y.

- I Transition Y produces photons of higher frequency than transition X
- II Transition X produces photons of longer wavelength than transition Y
- III When an electron is in the energy level  $E_0$ , the atom is ionised.

Which of the statements is/are correct?

- A I only
- B I and II only
- C I and III only
- D II and III only
- E I, II and III

17. The output of a signal generator is connected to the input of an oscilloscope. The trace produced on the screen of the oscilloscope is shown.

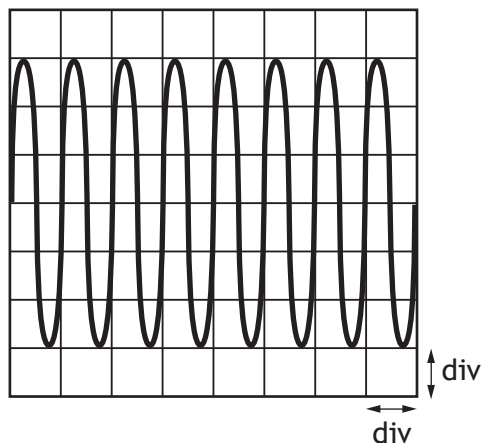

The timebase control of the oscilloscope is set at 2 ms/div.

The Y-gain control of the oscilloscope is set at 4 mV/div.

Which row in the table shows the frequency and peak voltage of the output of the signal generator?

	<i>frequency (Hz)</i>	<i>peak voltage (mV)</i>
A	0.5	12
B	0.5	6
C	250	6
D	500	12
E	500	24

[Turn over

18. A potential divider circuit is set up as shown.

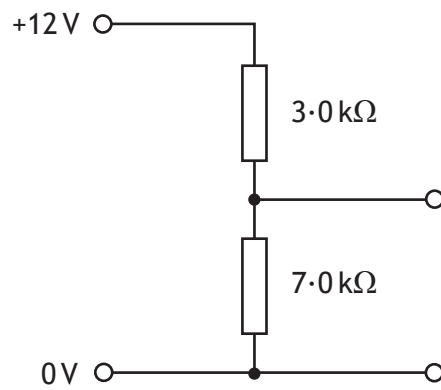

The potential difference across the 7.0 kΩ resistor is

- A 3.6 V
- B 4.0 V
- C 5.1 V
- D 8.4 V
- E 9.0 V.

19. A circuit is set up as shown.

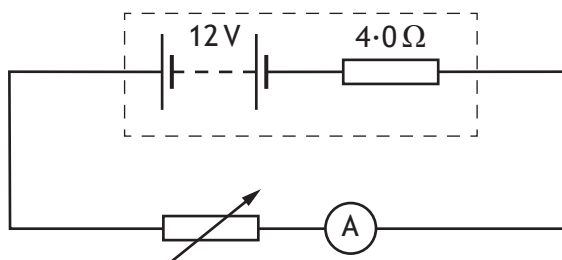

The resistance of the variable resistor is increased and corresponding readings on the ammeter are recorded.

<i>Resistance (<math>\Omega</math>)</i>	2.0	4.0	6.0	8.0
<i>Current (A)</i>	2.0	1.5	1.2	1.0

These results show that as the resistance of the variable resistor increases the power dissipated in the variable resistor

- A increases
- B decreases
- C remains constant
- D decreases and then increases
- E increases and then decreases.

20. A  $20\ \mu\text{F}$  capacitor is connected to a 12 V d.c. supply.

The maximum charge stored on the capacitor is

- A  $1.4 \times 10^{-3}\ \text{C}$
- B  $2.4 \times 10^{-4}\ \text{C}$
- C  $1.2 \times 10^{-4}\ \text{C}$
- D  $1.7 \times 10^{-6}\ \text{C}$
- E  $6.0 \times 10^{-7}\ \text{C}$ .

[END OF SECTION 1. NOW ATTEMPT THE QUESTIONS IN SECTION 2  
OF YOUR QUESTION AND ANSWER BOOKLET]

[BLANK PAGE]

DO NOT WRITE ON THIS PAGE

[BLANK PAGE]

DO NOT WRITE ON THIS PAGE

[BLANK PAGE]

DO NOT WRITE ON THIS PAGE

FOR OFFICIAL USE



--	--	--	--	--	--

National  
Qualifications  
2016

Mark

--

**X757/76/01**

**Physics  
Section 1 — Answer Grid  
and Section 2**

TUESDAY, 24 MAY  
9:00 AM – 11:30 AM



\* X 7 5 7 7 6 0 1 \*

Fill in these boxes and read what is printed below.

Full name of centre

Town

--

Forename(s)

Surname

Number of seat

--

--

--

Date of birth

Day

Month

Year

Scottish candidate number

--	--

--	--

--	--

--	--	--	--	--	--	--	--	--	--

**Total marks — 130**

**SECTION 1 — 20 marks**

Attempt ALL questions.

Instructions for the completion of Section 1 are given on *Page 02*.

**SECTION 2 — 110 marks**

Attempt ALL questions.

Reference may be made to the Data Sheet on *Page 02* of the question paper X757/76/02 and to the Relationships Sheet X757/76/11.

Care should be taken to give an appropriate number of significant figures in the final answers to calculations.

Write your answers clearly in the spaces provided in this booklet. Additional space for answers and rough work is provided at the end of this booklet. If you use this space you must clearly identify the question number you are attempting. Any rough work must be written in this booklet. You should score through your rough work when you have written your final copy.

Use **blue** or **black** ink.

Before leaving the examination room you must give this booklet to the Invigilator; if you do not, you may lose all the marks for this paper.



\* X 7 5 7 7 6 0 1 0 1 \*

The questions for Section 1 are contained in the question paper X757/76/02.

Read these and record your answers on the answer grid on *Page 03* opposite.

Use **blue** or **black** ink. Do NOT use gel pens or pencil.

1. The answer to each question is **either** A, B, C, D or E. Decide what your answer is, then fill in the appropriate bubble (see sample question below).
2. There is **only one correct** answer to each question.
3. Any rough work must be written in the additional space for answers and rough work at the end of this booklet.

### Sample Question

The energy unit measured by the electricity meter in your home is the:

- A ampere
- B kilowatt-hour
- C watt
- D coulomb
- E volt.

The correct answer is **B** — kilowatt-hour. The answer **B** bubble has been clearly filled in (see below).

<b>A</b>	<b>B</b>	<b>C</b>	<b>D</b>	<b>E</b>
<input type="radio"/>	<input checked="" type="radio"/>	<input type="radio"/>	<input type="radio"/>	<input type="radio"/>

### Changing an answer

If you decide to change your answer, cancel your first answer by putting a cross through it (see below) and fill in the answer you want. The answer below has been changed to **D**.

<b>A</b>	<b>B</b>	<b>C</b>	<b>D</b>	<b>E</b>
<input type="radio"/>	<input checked="" type="radio"/>	<input type="radio"/>	<input checked="" type="radio"/>	<input type="radio"/>

If you then decide to change back to an answer you have already scored out, put a tick (✓) to the **right** of the answer you want, as shown below:

<b>A</b>	<b>B</b>	<b>C</b>	<b>D</b>	<b>E</b>	or	<b>A</b>	<b>B</b>	<b>C</b>	<b>D</b>	<b>E</b>
<input type="radio"/>	<input checked="" type="radio"/>	<input type="radio"/>	<input checked="" type="radio"/>	<input type="radio"/>		<input type="radio"/>	<input checked="" type="radio"/>	<input type="radio"/>	<input type="radio"/>	<input type="radio"/>



## SECTION 1 — Answer Grid



	A	B	C	D	E
1	<input type="radio"/>	<input type="radio"/>	<input type="radio"/>	<input type="radio"/>	<input type="radio"/>
2	<input type="radio"/>	<input type="radio"/>	<input type="radio"/>	<input type="radio"/>	<input type="radio"/>
3	<input type="radio"/>	<input type="radio"/>	<input type="radio"/>	<input type="radio"/>	<input type="radio"/>
4	<input type="radio"/>	<input type="radio"/>	<input type="radio"/>	<input type="radio"/>	<input type="radio"/>
5	<input type="radio"/>	<input type="radio"/>	<input type="radio"/>	<input type="radio"/>	<input type="radio"/>
6	<input type="radio"/>	<input type="radio"/>	<input type="radio"/>	<input type="radio"/>	<input type="radio"/>
7	<input type="radio"/>	<input type="radio"/>	<input type="radio"/>	<input type="radio"/>	<input type="radio"/>
8	<input type="radio"/>	<input type="radio"/>	<input type="radio"/>	<input type="radio"/>	<input type="radio"/>
9	<input type="radio"/>	<input type="radio"/>	<input type="radio"/>	<input type="radio"/>	<input type="radio"/>
10	<input type="radio"/>	<input type="radio"/>	<input type="radio"/>	<input type="radio"/>	<input type="radio"/>
11	<input type="radio"/>	<input type="radio"/>	<input type="radio"/>	<input type="radio"/>	<input type="radio"/>
12	<input type="radio"/>	<input type="radio"/>	<input type="radio"/>	<input type="radio"/>	<input type="radio"/>
13	<input type="radio"/>	<input type="radio"/>	<input type="radio"/>	<input type="radio"/>	<input type="radio"/>
14	<input type="radio"/>	<input type="radio"/>	<input type="radio"/>	<input type="radio"/>	<input type="radio"/>
15	<input type="radio"/>	<input type="radio"/>	<input type="radio"/>	<input type="radio"/>	<input type="radio"/>
16	<input type="radio"/>	<input type="radio"/>	<input type="radio"/>	<input type="radio"/>	<input type="radio"/>
17	<input type="radio"/>	<input type="radio"/>	<input type="radio"/>	<input type="radio"/>	<input type="radio"/>
18	<input type="radio"/>	<input type="radio"/>	<input type="radio"/>	<input type="radio"/>	<input type="radio"/>
19	<input type="radio"/>	<input type="radio"/>	<input type="radio"/>	<input type="radio"/>	<input type="radio"/>
20	<input type="radio"/>	<input type="radio"/>	<input type="radio"/>	<input type="radio"/>	<input type="radio"/>



[BLANK PAGE]

DO NOT WRITE ON THIS PAGE



\* X 7 5 7 7 6 0 1 0 4 \*

[Turn over for SECTION 2

DO NOT WRITE ON THIS PAGE



\* X 7 5 7 7 6 0 1 0 5 \*

SECTION 2 — 110 marks  
Attempt ALL questions

1.

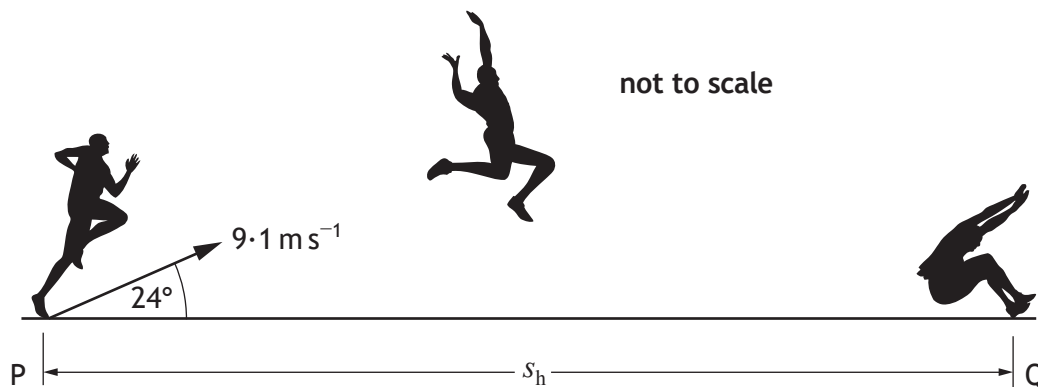

An athlete takes part in a long jump competition. The athlete takes off from point P with an initial velocity of  $9.1 \text{ m s}^{-1}$  at an angle of  $24^\circ$  to the horizontal and lands at point Q.

(a) Calculate:

- (i) the vertical component of the initial velocity of the athlete; 1

*Space for working and answer*

- (ii) the horizontal component of the initial velocity of the athlete. 1

*Space for working and answer*



1. (continued)

- (b) Show that the time taken for the athlete to travel from P to Q is 0.76 s. 2  
*Space for working and answer*

- (c) Calculate the horizontal displacement  $s_h$  between points P and Q. 3  
*Space for working and answer*

- (d) The graph shows how the horizontal displacement of the athlete varies with time for this jump when air resistance is ignored.

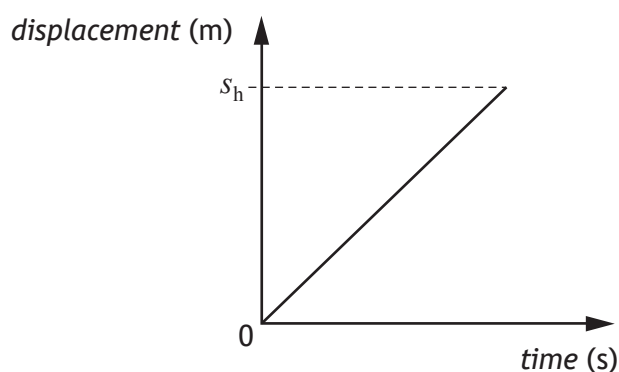

- Add a line to the graph to show how the horizontal displacement of the athlete varies with time when air resistance is taken into account. 2

(An additional graph, if required can be found on *Page 38*)



2. A student uses the apparatus shown to investigate the force of friction between the wheels of a toy car and a carpet.

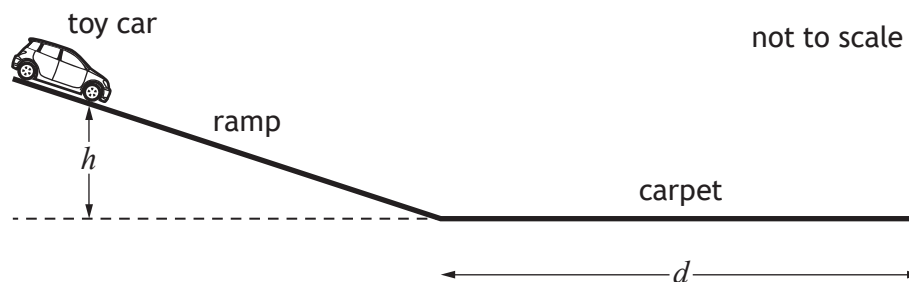

The toy car is released from rest, from a height  $h$ . It then travels down the ramp and along the carpet before coming to rest. The student measures the distance  $d$  that the car travels along the carpet.

The student repeats the procedure several times and records the following measurements and uncertainties.

Mass of car,  $m$ :  $(0.20 \pm 0.01)$  kg

Height,  $h$ :  $(0.40 \pm 0.005)$  m

Distance,  $d$ : 1.31 m    1.40 m    1.38 m    1.41 m    1.35 m

- (a) (i) Calculate the mean distance  $d$  travelled by the car. 1

*Space for working and answer*

- (ii) Calculate the approximate random uncertainty in this value. 2

*Space for working and answer*



2. (continued)

- (b) Determine which of the quantities; mass  $m$ , height  $h$  or mean distance  $d$ , has the largest percentage uncertainty.

You must justify your answer by calculation.

*Space for working and answer*

4

- (c) (i) Calculate the potential energy of the toy car at height  $h$ .

An uncertainty in this value is not required.

*Space for working and answer*

3

[Turn over



\* X 7 5 7 7 6 0 1 0 9 \*

2. (c) (continued)

(ii) Calculate the average force of friction acting between the toy car and carpet, as the car comes to rest.

An uncertainty in this value is not required.

*Space for working and answer*

3

(iii) State one assumption you have made in (c) (ii).

1



\* X 7 5 7 7 6 0 1 1 0 \*

[Turn over for next question

DO NOT WRITE ON THIS PAGE



\* X 7 5 7 7 6 0 1 1 1 \*

3. The following apparatus is set up to investigate the law of conservation of linear momentum.

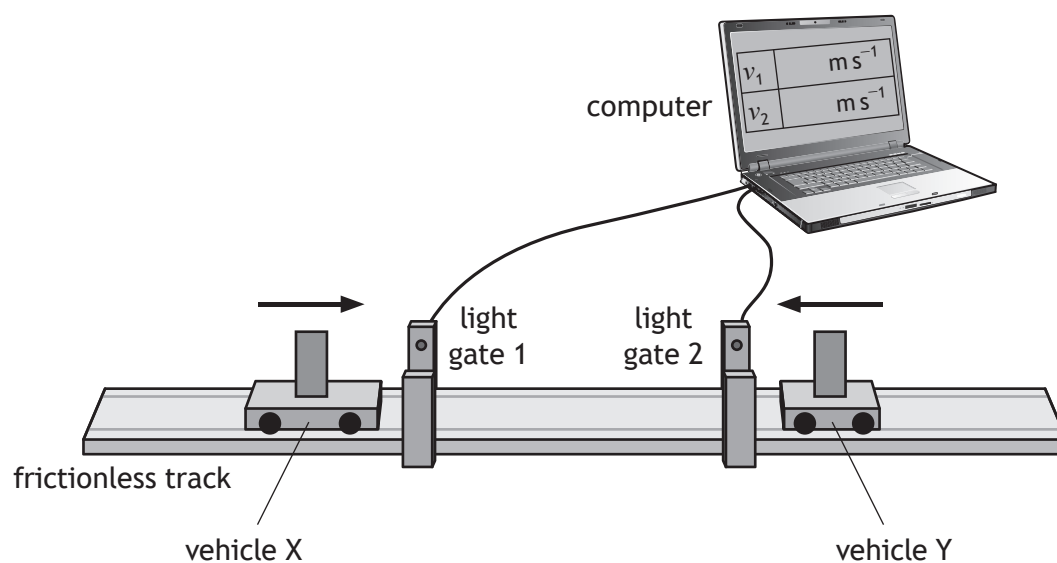

In one experiment, vehicle X is travelling to the right along the track and vehicle Y is travelling to the left along the track.

The vehicles collide and stick together.

The computer displays the speeds of each vehicle before the collision.

The following data are recorded:

Mass of vehicle X = 0.85 kg

Mass of vehicle Y = 0.25 kg

Speed of vehicle X before the collision =  $0.55 \text{ m s}^{-1}$

Speed of vehicle Y before the collision =  $0.30 \text{ m s}^{-1}$

- (a) State the law of conservation of linear momentum. 1
- (b) Calculate the velocity of the vehicles immediately after the collision. 3  
*Space for working and answer*



MARKS

DO NOT  
WRITE IN  
THIS  
MARGIN

3. (continued)

(c) Show by calculation that the collision is inelastic.

*Space for working and answer*

4

[Turn over



\* X 7 5 7 7 6 0 1 1 3 \*

4. Two physics students are in an airport building on their way to visit CERN.
- (a) The first student steps onto a moving walkway, which is travelling at  $0.83 \text{ m s}^{-1}$  relative to the building. This student walks along the walkway at a speed of  $1.20 \text{ m s}^{-1}$  relative to the walkway.

The second student walks alongside the walkway at a speed of  $1.80 \text{ m s}^{-1}$  relative to the building.

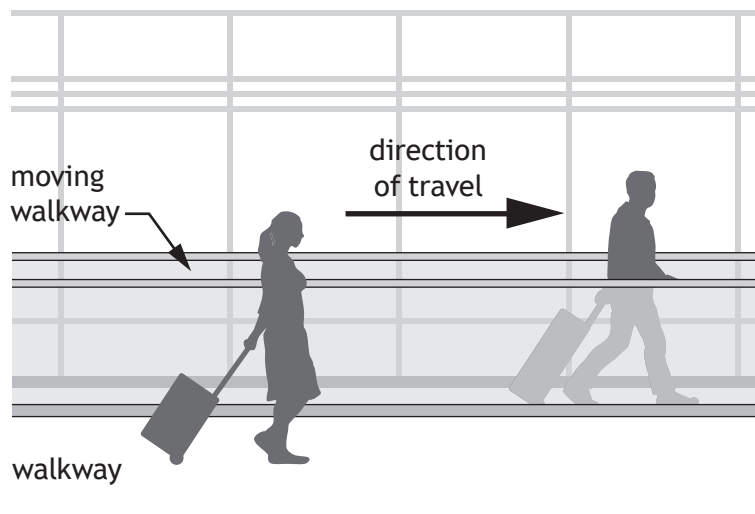

Determine the speed of the first student relative to the second student. 2

*Space for working and answer*



4. (continued)

(b) On the plane, the students discuss the possibility of travelling at relativistic speeds.

(i) The students consider the plane travelling at  $0.8c$  relative to a stationary observer. The plane emits a beam of light towards the observer.

State the speed of the emitted light as measured by the observer.

Justify your answer.

2

(ii) According to the manufacturer, the length of the plane is 71 m.

Calculate the length of the plane travelling at  $0.8c$  as measured by the stationary observer.

3

*Space for working and answer*

(iii) One of the students states that the clocks on board the plane will run slower when the plane is travelling at relativistic speeds.

Explain whether or not this statement is correct.

1

[Turn over



\* X 7 5 7 7 6 0 1 1 5 \*

5. (a) A student is using an elastic band to model the expansion of the Universe.

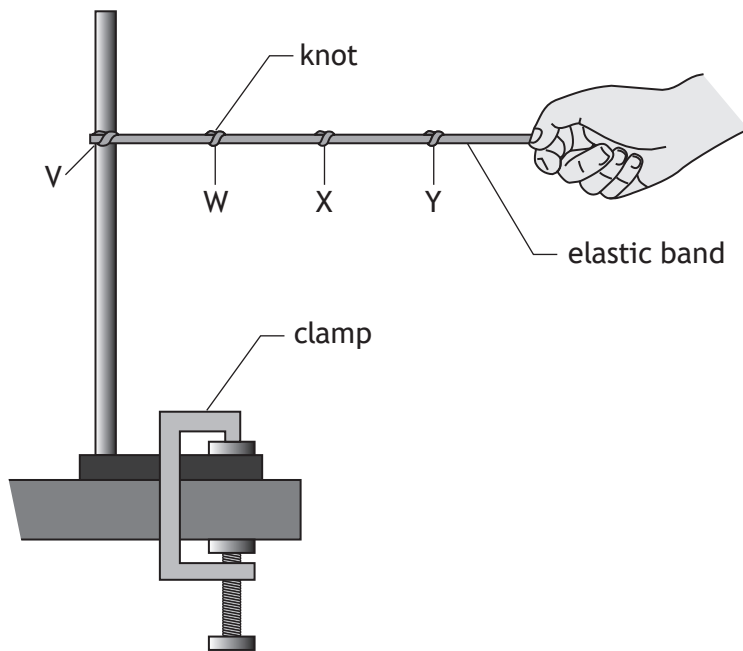

One end of the band is fixed in a clamp stand at V. Knots are tied in the band to represent galaxies. The knots are at regular intervals of 0.10 m, at points W, X and Y as shown.

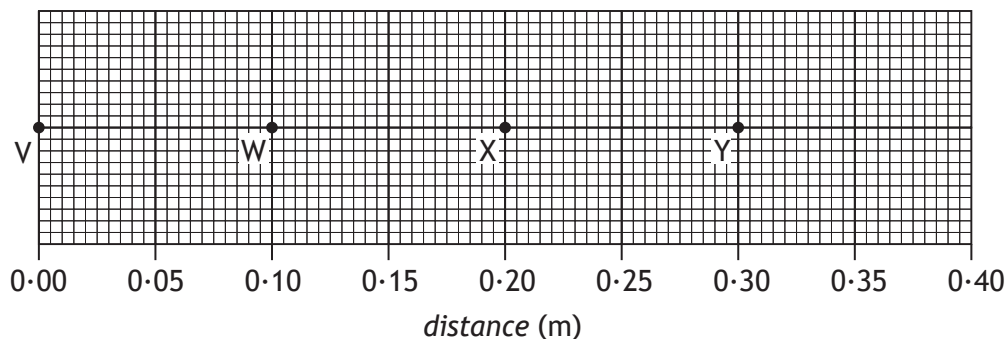

The other end of the elastic band is pulled slowly for 2.5 seconds, so that the band stretches. The knots are now in the positions shown below.

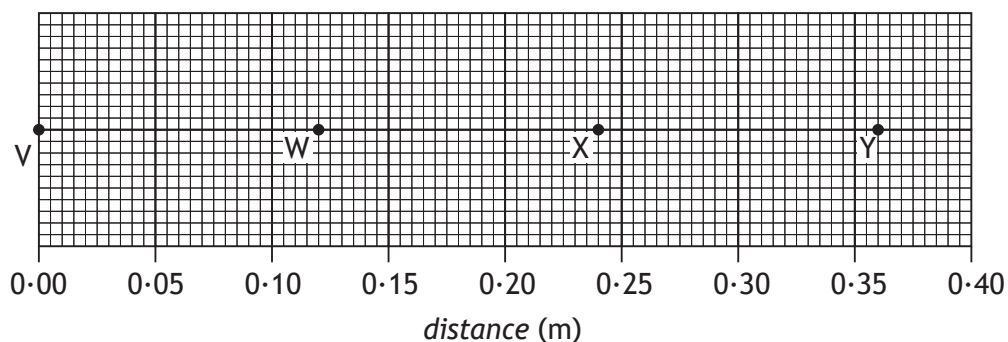

5. (a) (continued)

- (i) Complete the table to show the average speeds of the knots X and Y. 2

<i>Knot</i>	<i>Average speed (m s<sup>-1</sup>)</i>
W	0.008
X	
Y	

*Space for working*

- (ii) Explain why this model is a good simulation of the expansion of the Universe. 1

[Turn over



5. (continued)

- (b) When viewed from the Earth, the continuous emission spectrum from the Sun has a number of dark lines. One of these lines is at a wavelength of 656 nm.



In the spectrum of light from a distant galaxy, the corresponding dark line is observed at 667 nm.

Calculate the redshift of the light from the distant galaxy.

3

*Space for working and answer*



MARKS

DO NOT  
WRITE IN  
THIS  
MARGIN

6. A website states “*Atoms are like tiny solar systems with electrons orbiting a nucleus like the planets orbit the Sun*”.

Use your knowledge of physics to comment on this statement.

3

[Turn over



\* X 7 5 7 7 6 0 1 1 9 \*

7. An experiment is set up to investigate the behaviour of electrons in electric fields.

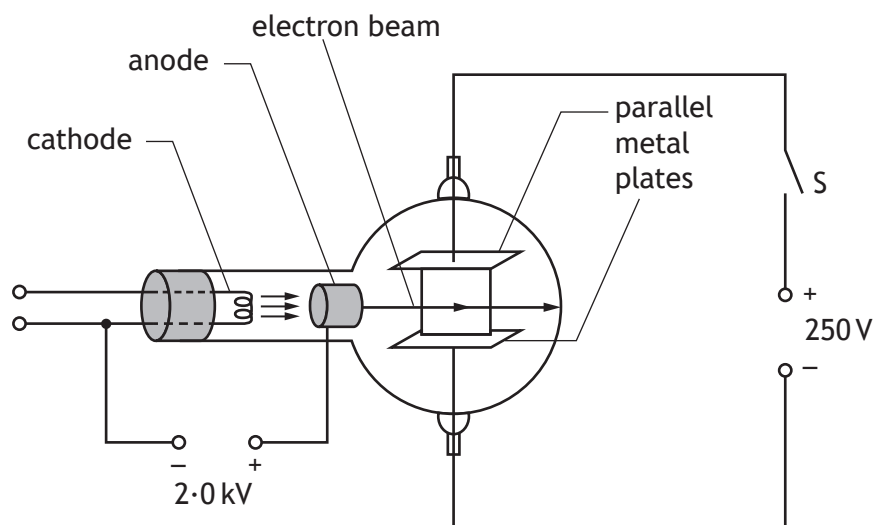

- (a) Electrons are accelerated from rest between the cathode and the anode by a potential difference of 2.0 kV.

Calculate the kinetic energy gained by each electron as it reaches the anode.

3

*Space for working and answer*

- (b) The electrons then pass between the two parallel metal plates.

The electron beam current is 8.0 mA.

Determine the number of electrons passing between the metal plates in one minute.

4

*Space for working and answer*



\* X 7 5 7 7 6 0 1 2 0 \*

7. (continued)

(c) The switch S is now closed.

The potential difference between the metal plates is 250 V.

The path of the electron beam between the metal plates is shown.

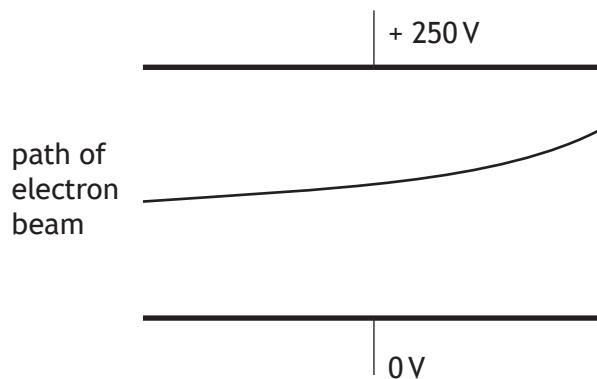

Complete the diagram to show the electric field pattern between the two metal plates.

1

(An additional diagram, if required, can be found on *Page 38*.)

[Turn over



8. The diagram shows part of an experimental fusion reactor.

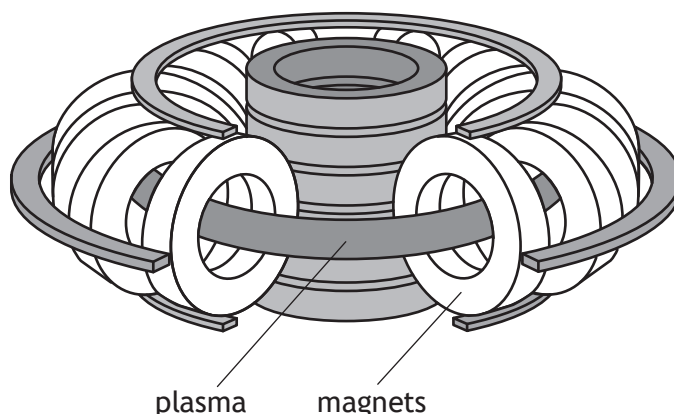

The following statement represents a reaction that takes place inside the reactor.

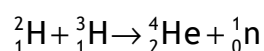

The masses of the particles involved in the reaction are shown in the table.

Particle	Mass (kg)
${}^2_1\text{H}$	$3.3436 \times 10^{-27}$
${}^3_1\text{H}$	$5.0083 \times 10^{-27}$
${}^4_2\text{He}$	$6.6465 \times 10^{-27}$
${}^1_0\text{n}$	$1.6749 \times 10^{-27}$

(a) Explain why energy is released in this reaction.

1

(b) Calculate the energy released in this reaction.

4

*Space for working and answer*



8. (continued)

- (c) Magnetic fields are used to contain the plasma inside the fusion reactor.  
 Explain why it is necessary to use a magnetic field to contain the plasma. 1

- (d) The plasma consists of charged particles. A positively charged particle enters a region of the magnetic field as shown.

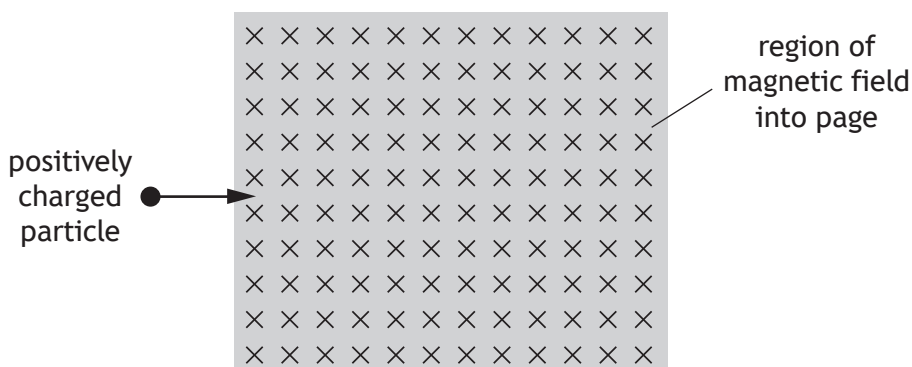

- Determine the direction of the force exerted by the magnetic field on the positively charged particle as it enters the field. 1

[Turn over



9. A student carries out an experiment to measure the wavelength of microwave radiation. Microwaves pass through two gaps between metal plates as shown.

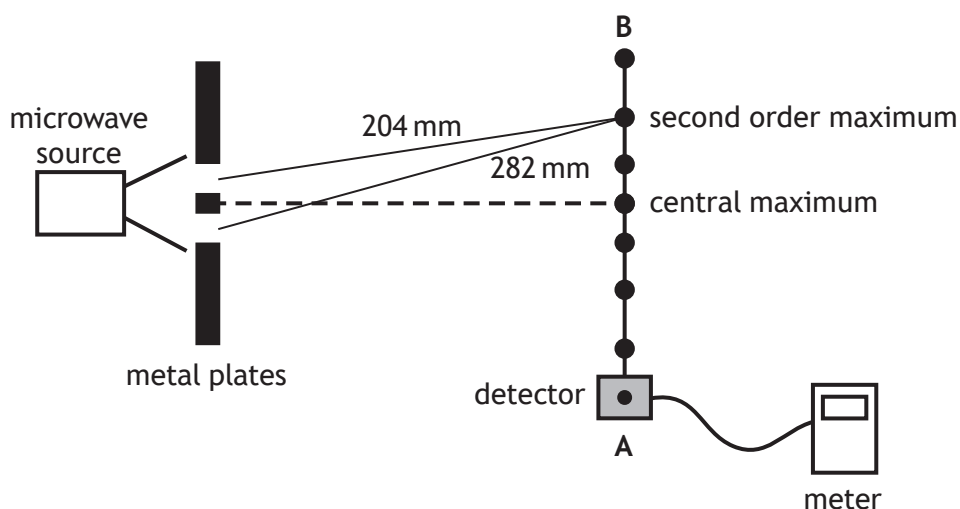

As the detector is moved from A to B, a series of maxima and minima are detected.

- (a) The microwaves passing through the gaps are coherent.  
State what is meant by the term *coherent*.

1

- (b) Explain, in terms of waves, how a maximum is produced.

1

- (c) The measurements of the distance from each gap to the second order maximum are shown in the diagram above.

Calculate the wavelength of the microwaves.

3

*Space for working and answer*



\* X 7 5 7 7 6 0 1 2 4 \*

MARKS

DO NOT  
WRITE IN  
THIS  
MARGIN

9. (continued)

(d) The distance separating the two gaps is now increased.

State what happens to the path difference to the second order maximum.

Justify your answer.

2

[Turn over



\* X 7 5 7 7 6 0 1 2 5 \*

10. Retroflective materials reflect light to enhance the visibility of clothing.

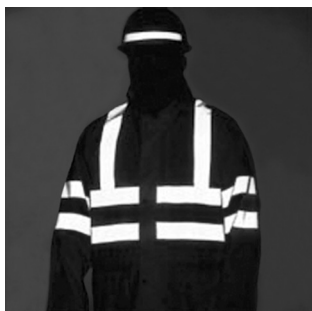

One type of retroflective material is made from small glass spheres partially embedded in a silver-coloured surface that reflects light.

A ray of monochromatic light follows the path shown as it enters one of the glass spheres.

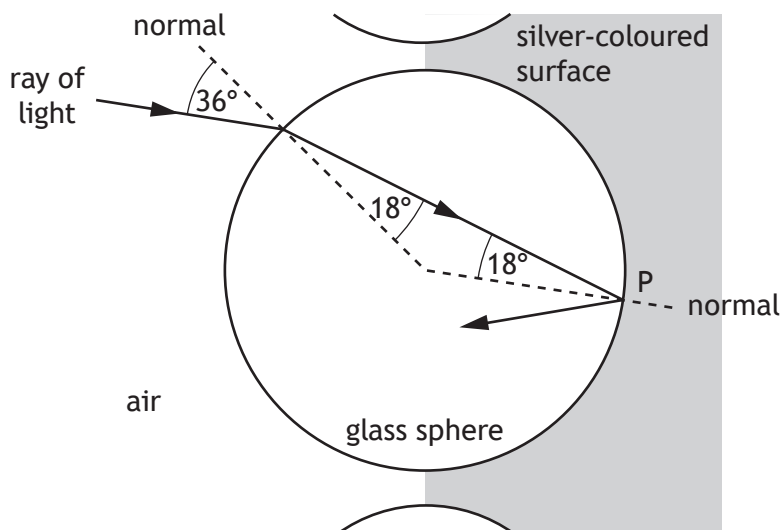

(a) Calculate the refractive index of the glass for this light.

3

*Space for working and answer*



10. (continued)

(b) Calculate the critical angle for this light in the glass.

*Space for working and answer*

3

(c) The light is reflected at point P.

Complete the diagram below to show the path of the ray as it passes through the sphere and emerges into the air.

1

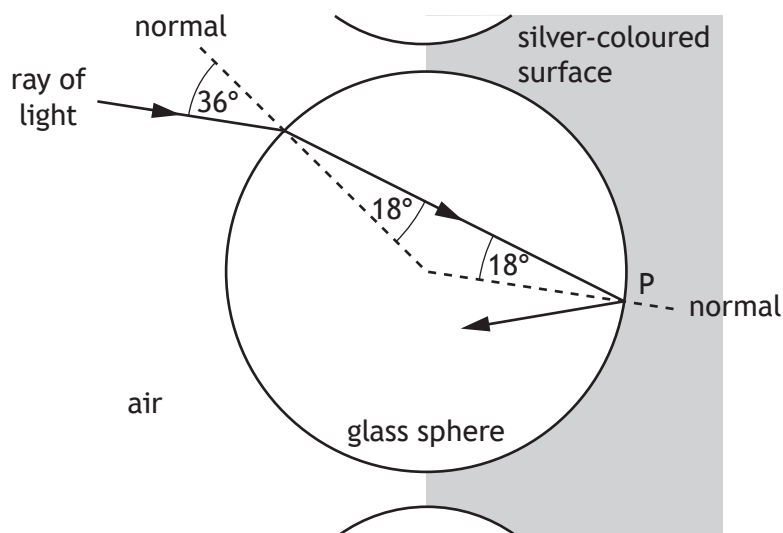

(An additional diagram, if required, can be found on *Page 38.*)

[Turn over



\* X 7 5 7 7 6 0 1 2 7 \*

11. A student is describing how the following circuit works.

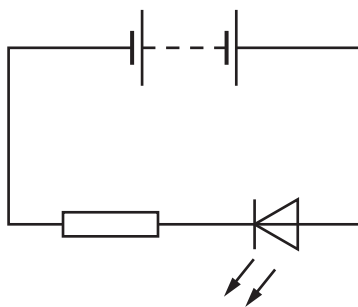

The student states:

“The electricity comes out of the battery with energy and flows through the resistor using up some of the energy, it then goes through the LED and the rest of the energy is changed into light waves.”

Use your knowledge of physics to comment on this statement.

3



12. A technician sets up a circuit as shown, using a car battery and two identical lamps.

The battery has an e.m.f. of  $12.8\text{ V}$  and an internal resistance of  $0.10\ \Omega$ .

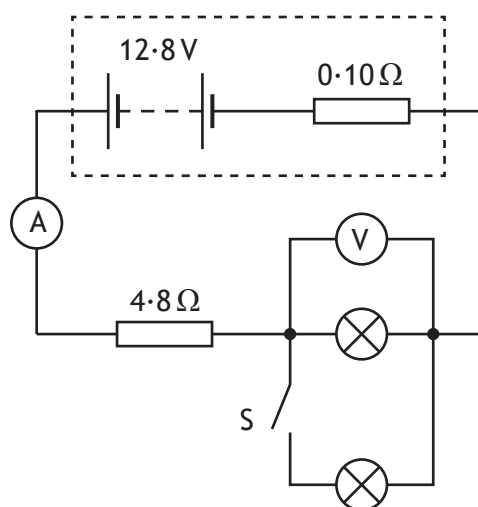

(a) Switch S is open. The reading on the ammeter is  $1.80\text{ A}$ .

(i) Determine the reading on the voltmeter.

4

*Space for working and answer*

(ii) Switch S is now closed.

State the effect this has on the reading on the voltmeter.

Justify your answer.

3



\* X 7 5 7 7 6 0 1 2 9 \*

- (b) Some cars use LEDs in place of filament lamps.

An LED is made from semiconductor material that has been doped with impurities to create a p-n junction.

The diagram represents the band structure of an LED.

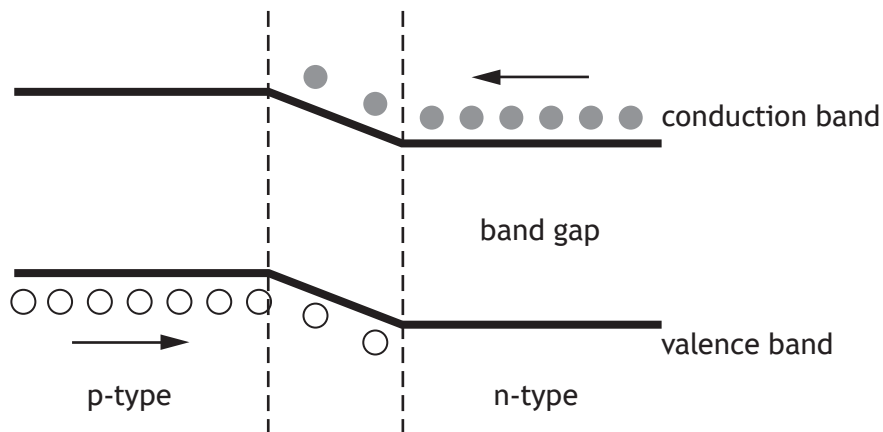

- (i) A voltage is applied across an LED so that it is forward biased and emits light.

Using **band theory**, explain how the LED emits light.

3



\* X 7 5 7 7 6 0 1 3 0 \*

12. (b) (continued)

MARKS  
DO NOT  
WRITE IN  
THIS  
MARGIN

- (ii) The energy gap between the valence band and conduction band is known as the band gap.

The band gap for the LED is  $3.03 \times 10^{-19} \text{ J}$

- (A) Calculate the wavelength of the light emitted by the LED.

4

*Space for working and answer*

- (B) Determine the colour of the light emitted by the LED.

1

[Turn over



\* X 7 5 7 7 6 0 1 3 1 \*

13. A technician sets up a circuit as shown.

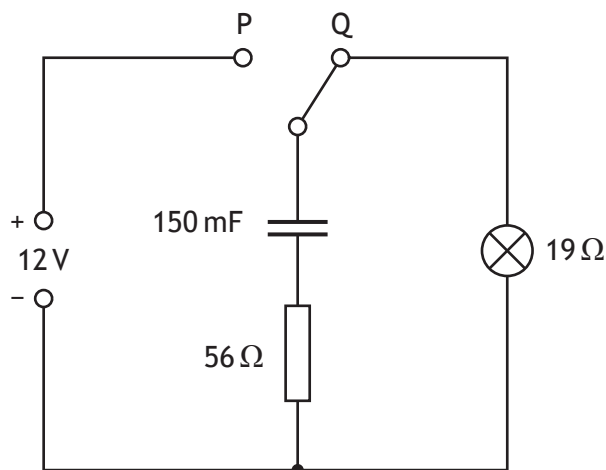

The power supply has negligible internal resistance.

(a) The capacitor is initially uncharged.

The switch is moved to position P and the capacitor charges.

(i) State the potential difference across the capacitor when it is fully charged.

1

(ii) Calculate the maximum energy stored by the capacitor.

3

*Space for working and answer*



\* X 7 5 7 7 6 0 1 3 2 \*

13. (continued)

MARKS  
DO NOT  
WRITE IN  
THIS  
MARGIN

- (b) The switch is now moved back to position Q.  
Determine the maximum discharge current in the circuit.  
*Space for working and answer*

3

- (c) The technician replaces the 150 mF capacitor with a capacitor of capacitance 47 mF.  
The switch is moved to position P and the capacitor is fully charged.  
The switch is now moved to position Q.  
State the effect that this change has on the time the lamp stays lit.  
You must justify your answer.

2

[Turn over for next question



\* X 7 5 7 7 6 0 1 3 3 \*

14. A student investigates the factors affecting the frequency of sound produced by a vibrating guitar string.

The guitar string is stretched over two supports and is made to vibrate as shown.

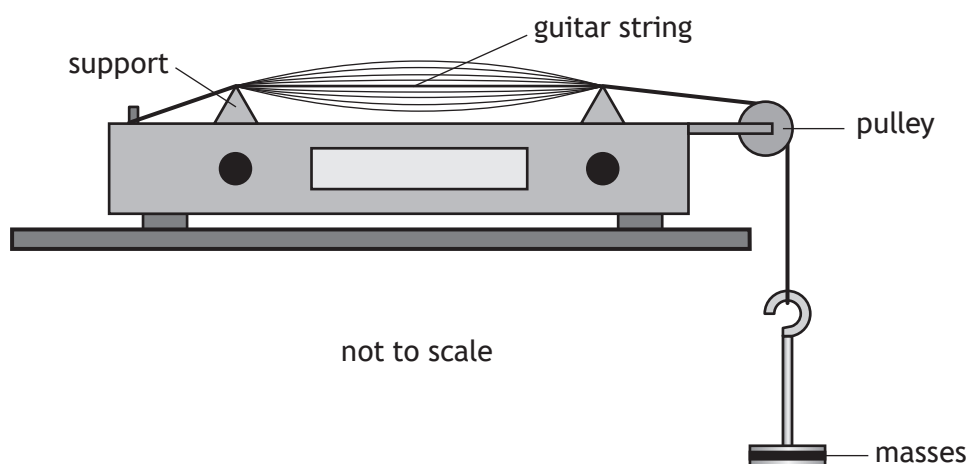

The frequency  $f$  of the sound produced by the vibrating string is given by the relationship

$$f = \frac{1}{2L} \sqrt{\frac{T}{\mu}}$$

where  $T$  is the tension in the string  
 $L$  is the distance between the supports  
 $\mu$  is the mass per unit length of the string.

- (a) The tension in the string is 49.0 N and the mass per unit length of the string is  $4.00 \times 10^{-4} \text{ kg m}^{-1}$ .

The distance between the supports is 0.550 m.

Calculate the frequency  $f$  of the sound produced.

2

Space for working and answer



14. (continued)

- (b) The guitar string in part (a) is replaced by a different guitar string.

A student varies the tension  $T$  and measures the frequency  $f$  of the sound produced by the new guitar string.

The student records the following information.

$T$ (N)	$\sqrt{T}$ (N <sup>½</sup> )	$f$ (Hz)
10	3.2	162
15	3.9	190
20	4.5	220
25	5.0	254
30	5.5	273

- (i) Using the square-ruled paper on *Page 36*, draw a graph of  $f$  against  $\sqrt{T}$  3
- (ii) Use your graph to determine the frequency of the sound produced when the tension in the guitar string is 22 N. 1

[END OF QUESTION PAPER]



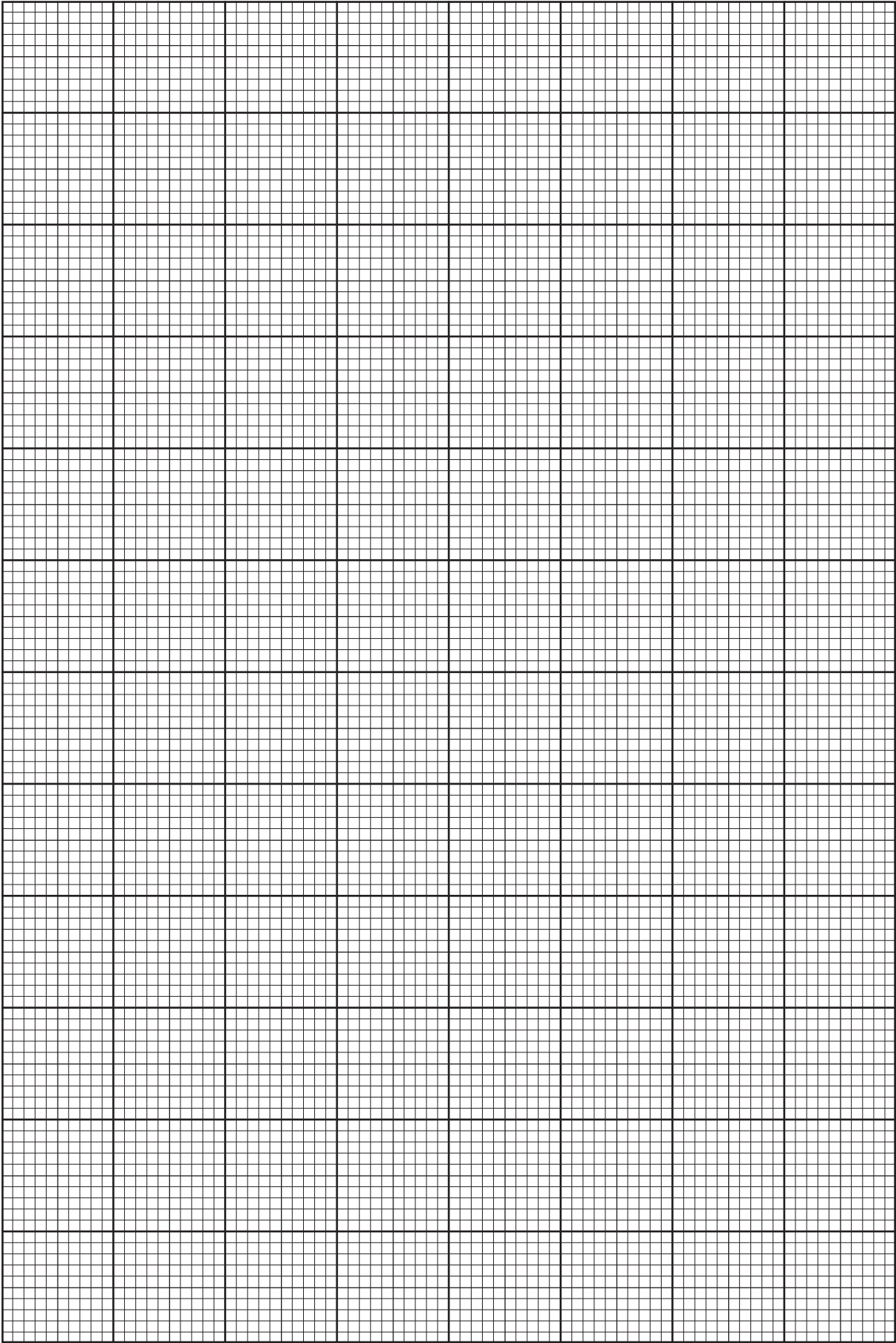

\* X 7 5 7 7 6 0 1 3 6 \*

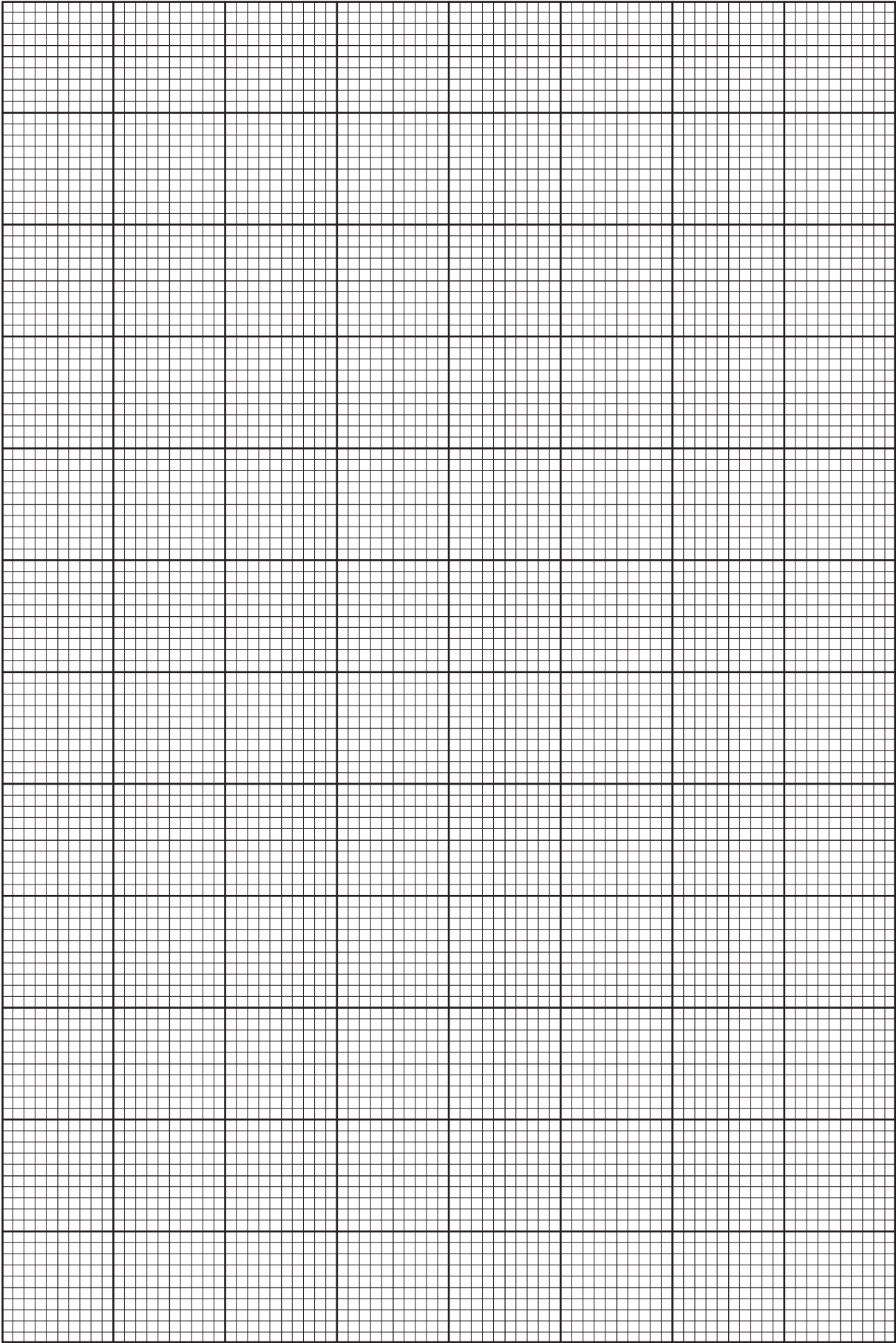

\* X 7 5 7 7 6 0 1 3 7 \*

Question 1 (d)

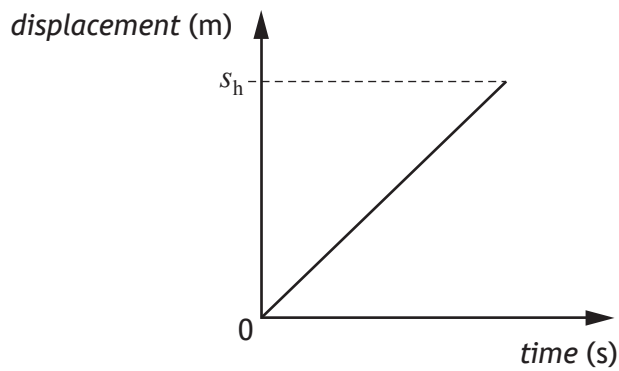

Question 7 (c)

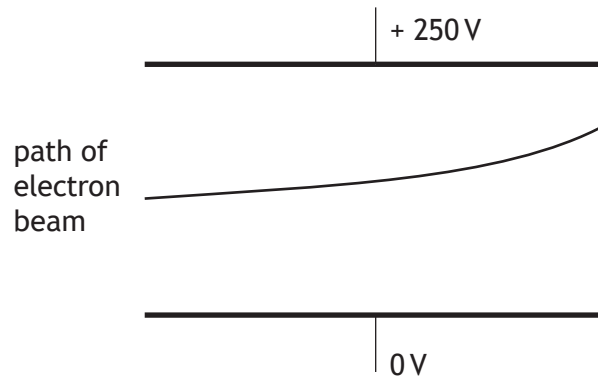

Question 10 (c)

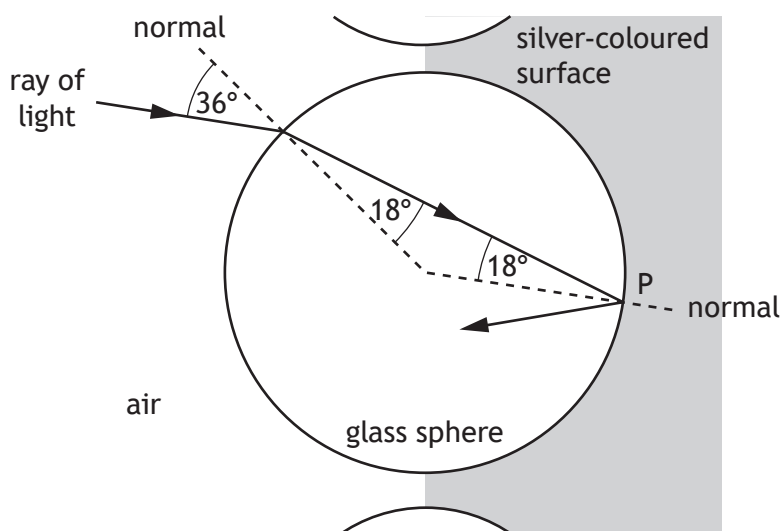

ADDITIONAL SPACE FOR ANSWERS AND ROUGH WORK

MARKS DO NOT  
WRITE IN  
THIS  
MARGIN



\* X 7 5 7 7 6 0 1 3 9 \*

ADDITIONAL SPACE FOR ANSWERS AND ROUGH WORK

MARKS DO NOT WRITE IN THIS MARGIN

ACKNOWLEDGEMENT

Section 2 Question 10 – Image of Reflective Safety Jacket, taken from <http://www.tradeget.com/listing/sri-balaji-associates/product-services-detail-62668/18652/1/1>).

SQA has made every effort to trace the owners of copyright materials reproduced in this question paper, and seek permissions. We will be happy to incorporate any missing acknowledgements. Please contact [Janine.Anderson@sqa.org.uk](mailto:Janine.Anderson@sqa.org.uk).



\* X 7 5 7 7 6 0 1 4 0 \*