



National
Qualifications
2016

X757/76/02

Physics
Section 1 — Questions

TUESDAY, 24 MAY
9:00 AM – 11:30 AM

Instructions for the completion of Section 1 are given on *Page 02* of your question and answer booklet X757/76/01.

Record your answers on the answer grid on *Page 03* of your question and answer booklet.

Reference may be made to the Data Sheet on *Page 02* of this booklet and to the Relationships Sheet X757/76/11.

Before leaving the examination room you must give your question and answer booklet to the Invigilator; if you do not, you may lose all the marks for this paper.



* X 7 5 7 7 6 0 2 *

DATA SHEET

COMMON PHYSICAL QUANTITIES

Quantity	Symbol	Value	Quantity	Symbol	Value
Speed of light in vacuum	c	$3.00 \times 10^8 \text{ m s}^{-1}$	Planck's constant	h	$6.63 \times 10^{-34} \text{ J s}$
Magnitude of the charge on an electron	e	$1.60 \times 10^{-19} \text{ C}$	Mass of electron	m_e	$9.11 \times 10^{-31} \text{ kg}$
Universal Constant of Gravitation	G	$6.67 \times 10^{-11} \text{ m}^3 \text{ kg}^{-1} \text{ s}^{-2}$	Mass of neutron	m_n	$1.675 \times 10^{-27} \text{ kg}$
Gravitational acceleration on Earth	g	9.8 m s^{-2}	Mass of proton	m_p	$1.673 \times 10^{-27} \text{ kg}$
Hubble's constant	H_0	$2.3 \times 10^{-18} \text{ s}^{-1}$			

REFRACTIVE INDICES

The refractive indices refer to sodium light of wavelength 589 nm and to substances at a temperature of 273 K.

Substance	Refractive index	Substance	Refractive index
Diamond	2.42	Water	1.33
Crown glass	1.50	Air	1.00

SPECTRAL LINES

Element	Wavelength/nm	Colour	Element	Wavelength/nm	Colour
Hydrogen	656	Red	Cadmium	644	Red
	486	Blue-green		509	Green
	434	Blue-violet		480	Blue
	410	Violet	Lasers		
	397	Ultraviolet	<i>Element</i>	<i>Wavelength/nm</i>	<i>Colour</i>
	389	Ultraviolet	Carbon dioxide	9550 } 10590 }	Infrared
Sodium	589	Yellow	Helium-neon	633	Red

PROPERTIES OF SELECTED MATERIALS

Substance	Density/kg m ⁻³	Melting Point/K	Boiling Point/K
Aluminium	2.70×10^3	933	2623
Copper	8.96×10^3	1357	2853
Ice	9.20×10^2	273
Sea Water	1.02×10^3	264	377
Water	1.00×10^3	273	373
Air	1.29
Hydrogen	9.0×10^{-2}	14	20

The gas densities refer to a temperature of 273 K and a pressure of $1.01 \times 10^5 \text{ Pa}$.

SECTION 1 — 20 marks

Attempt ALL questions

1. A car accelerates uniformly from rest. The car travels a distance of 60 m in 6.0 s. The acceleration of the car is

- A 0.83 m s^{-2}
- B 3.3 m s^{-2}
- C 5.0 m s^{-2}
- D 10 m s^{-2}
- E 20 m s^{-2} .

2. A ball is thrown vertically upwards and falls back to Earth.

Neglecting air resistance, which velocity-time graph represents its motion?

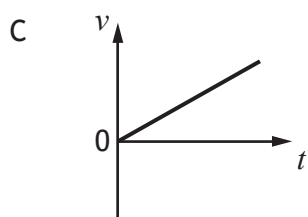
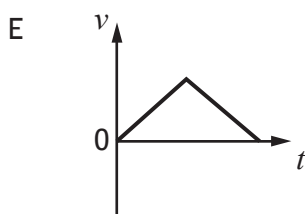
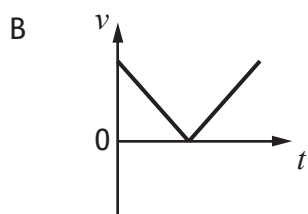
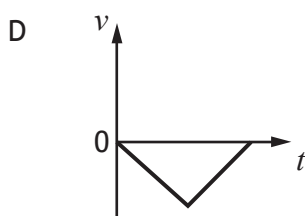
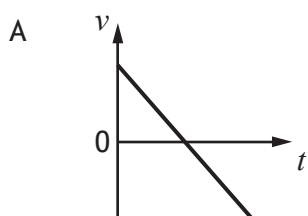

[Turn over

3. A block of wood slides with a constant velocity down a slope. The slope makes an angle of 30° with the horizontal as shown. The mass of the block is 2.0 kg .

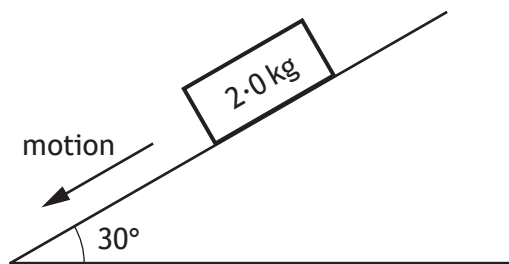

The magnitude of the force of friction acting on the block is

- A 1.0 N
 - B 1.7 N
 - C 9.8 N
 - D 17.0 N
 - E 19.6 N .
4. The graph shows the force which acts on an object over a time interval of 8.0 seconds.

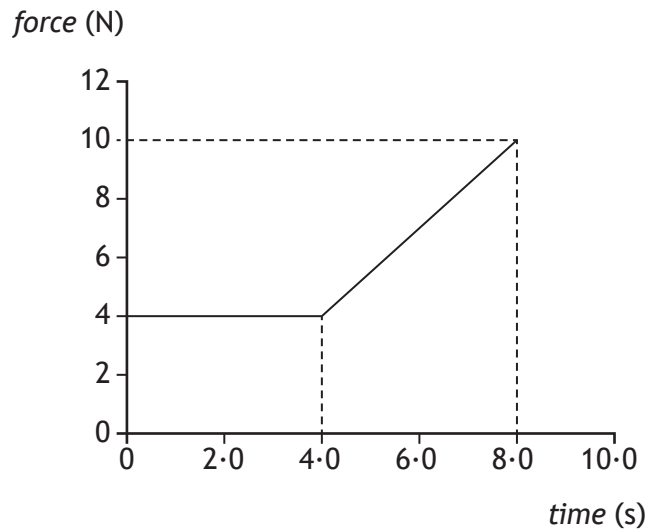

The momentum gained by the object during this 8.0 seconds is

- A 12 kg m s^{-1}
- B 32 kg m s^{-1}
- C 44 kg m s^{-1}
- D 52 kg m s^{-1}
- E 72 kg m s^{-1} .

5. A planet orbits a star at a distance of 3.0×10^9 m.
The star exerts a gravitational force of 1.6×10^{27} N on the planet.
The mass of the star is 6.0×10^{30} kg.
The mass of the planet is
- A 2.4×10^{14} kg
 - B 1.2×10^{16} kg
 - C 3.6×10^{25} kg
 - D 1.6×10^{26} kg
 - E 2.4×10^{37} kg.
6. A car horn emits a sound with a constant frequency of 405 Hz.
The car is travelling away from a student at 28.0 m s^{-1} .
The speed of sound in air is 335 m s^{-1} .
The frequency of the sound from the horn heard by the student is
- A 371 Hz
 - B 374 Hz
 - C 405 Hz
 - D 439 Hz
 - E 442 Hz.

[Turn over

7. The graphs show how the radiation per unit surface area, R , varies with the wavelength, λ , of the emitted radiation for two stars, P and Q.

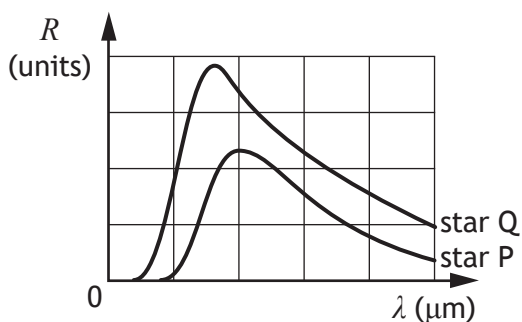

A student makes the following conclusions based on the information in the graph.

- I Star P is hotter than star Q.
- II Star P emits more radiation per unit surface area than star Q.
- III The peak intensity of the radiation from star Q is at a shorter wavelength than that from star P.

Which of these statements is/are correct?

- A I only
 - B II only
 - C III only
 - D I and II only
 - E II and III only
8. One type of hadron consists of two down quarks and one up quark.

The charge on a down quark is $-\frac{1}{3}$.

The charge on an up quark is $+\frac{2}{3}$.

Which row in the table shows the charge and type for this hadron?

	<i>charge</i>	<i>type of hadron</i>
A	0	baryon
B	+1	baryon
C	-1	meson
D	0	meson
E	+1	meson

9. A student makes the following statements about sub-nuclear particles.
- I The force mediating particles are bosons.
 - II Gluons are the mediating particles of the strong force.
 - III Photons are the mediating particles of the electromagnetic force.

Which of these statements is/are correct?

- A I only
 - B II only
 - C I and II only
 - D II and III only
 - E I, II and III
10. The last two changes in a radioactive decay series are shown below.
A Bismuth nucleus emits a beta particle and its product, a Polonium nucleus, emits an alpha particle.

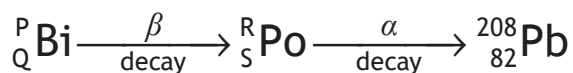

Which numbers are represented by P, Q, R and S?

	P	Q	R	S
A	210	83	208	81
B	210	83	210	84
C	211	85	207	86
D	212	83	212	84
E	212	85	212	84

[Turn over

11. The table below shows the threshold frequency of radiation for photoelectric emission for some metals.

<i>Metal</i>	<i>Threshold frequency (Hz)</i>
sodium	4.4×10^{14}
potassium	5.4×10^{14}
zinc	6.9×10^{14}

Radiation of frequency 6.3×10^{14} Hz is incident on the surface of each of the metals.

Photoelectric emission occurs from

- A sodium only
 - B zinc only
 - C potassium only
 - D sodium and potassium only
 - E zinc and potassium only.
12. Radiation of frequency 9.00×10^{15} Hz is incident on a clean metal surface.
- The maximum kinetic energy of a photoelectron ejected from this surface is 5.70×10^{-18} J.
- The work function of the metal is
- A 2.67×10^{-19} J
 - B 5.97×10^{-18} J
 - C 1.17×10^{-17} J
 - D 2.07×10^{-2} J
 - E 9.60×10^{-1} J.

13. A ray of monochromatic light is incident on a grating as shown.

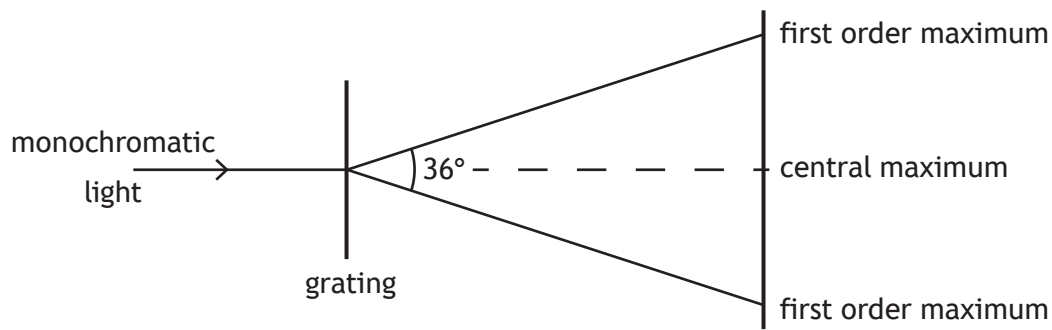

The wavelength of the light is 633 nm.

The separation of the slits on the grating is

- A 1.96×10^{-7} m
 B 1.08×10^{-6} m
 C 2.05×10^{-6} m
 D 2.15×10^{-6} m
 E 4.10×10^{-6} m.
14. Light travels from **glass** into **air**.
 Which row in the table shows what happens to the speed, frequency and wavelength of the light as it travels from glass into air?

	<i>Speed</i>	<i>Frequency</i>	<i>Wavelength</i>
A	decreases	stays constant	decreases
B	decreases	increases	stays constant
C	stays constant	increases	increases
D	increases	increases	stays constant
E	increases	stays constant	increases

15. The irradiance of light from a point source is 32 W m^{-2} at a distance of 4.0 m from the source.
 The irradiance of the light at a distance of 16 m from the source is
- A 0.125 W m^{-2}
 B 0.50 W m^{-2}
 C 2.0 W m^{-2}
 D 8.0 W m^{-2}
 E 128 W m^{-2} .

16. Part of the energy level diagram for an atom is shown

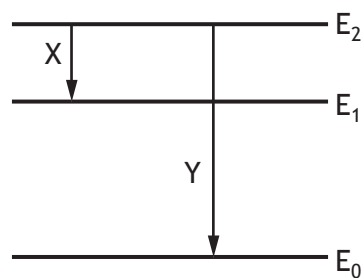

X and Y represent two possible electron transitions.

A student makes the following statements about transitions X and Y.

- I Transition Y produces photons of higher frequency than transition X
- II Transition X produces photons of longer wavelength than transition Y
- III When an electron is in the energy level E_0 , the atom is ionised.

Which of the statements is/are correct?

- A I only
- B I and II only
- C I and III only
- D II and III only
- E I, II and III

17. The output of a signal generator is connected to the input of an oscilloscope. The trace produced on the screen of the oscilloscope is shown.

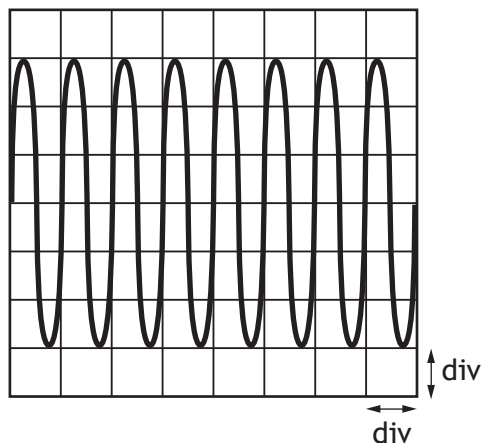

The timebase control of the oscilloscope is set at 2 ms/div.

The Y-gain control of the oscilloscope is set at 4 mV/div.

Which row in the table shows the frequency and peak voltage of the output of the signal generator?

	<i>frequency (Hz)</i>	<i>peak voltage (mV)</i>
A	0.5	12
B	0.5	6
C	250	6
D	500	12
E	500	24

[Turn over

18. A potential divider circuit is set up as shown.

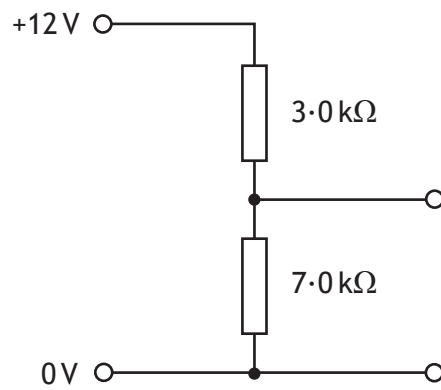

The potential difference across the 7.0 kΩ resistor is

- A 3.6 V
- B 4.0 V
- C 5.1 V
- D 8.4 V
- E 9.0 V.

19. A circuit is set up as shown.

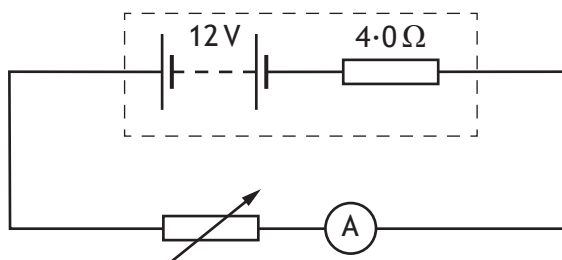

The resistance of the variable resistor is increased and corresponding readings on the ammeter are recorded.

<i>Resistance (Ω)</i>	2.0	4.0	6.0	8.0
<i>Current (A)</i>	2.0	1.5	1.2	1.0

These results show that as the resistance of the variable resistor increases the power dissipated in the variable resistor

- A increases
- B decreases
- C remains constant
- D decreases and then increases
- E increases and then decreases.

20. A $20\ \mu\text{F}$ capacitor is connected to a 12 V d.c. supply.

The maximum charge stored on the capacitor is

- A $1.4 \times 10^{-3}\ \text{C}$
- B $2.4 \times 10^{-4}\ \text{C}$
- C $1.2 \times 10^{-4}\ \text{C}$
- D $1.7 \times 10^{-6}\ \text{C}$
- E $6.0 \times 10^{-7}\ \text{C}$.

[END OF SECTION 1. NOW ATTEMPT THE QUESTIONS IN SECTION 2
OF YOUR QUESTION AND ANSWER BOOKLET]

[BLANK PAGE]

DO NOT WRITE ON THIS PAGE

[BLANK PAGE]

DO NOT WRITE ON THIS PAGE

[BLANK PAGE]

DO NOT WRITE ON THIS PAGE