

FOR OFFICIAL USE



--	--	--	--	--	--

National  
Qualifications  
2017

Mark

--

**X757/76/01**

**Physics  
Section 1 — Answer Grid  
and Section 2**

WEDNESDAY, 17 MAY

9:00 AM – 11:30 AM



\* X 7 5 7 7 6 0 1 \*

Fill in these boxes and read what is printed below.

Full name of centre

--

Town

--

Forename(s)

--

Surname

--

Number of seat

--

Date of birth

Day

--	--

Month

--	--

Year

--	--

Scottish candidate number

--	--	--	--	--	--	--	--	--	--

**Total marks — 130**

**SECTION 1 — 20 marks**

Attempt ALL questions.

Instructions for the completion of Section 1 are given on *Page 02*.

**SECTION 2 — 110 marks**

Attempt ALL questions.

Reference may be made to the Data Sheet on *Page 02* of the question paper X757/76/02 and to the Relationship Sheet X757/76/11.

Care should be taken to give an appropriate number of significant figures in the final answers to calculations.

Write your answers clearly in the spaces provided in this booklet. Additional space for answers and rough work is provided at the end of this booklet. If you use this space you must clearly identify the question number you are attempting. Any rough work must be written in this booklet. You should score through your rough work when you have written your final copy.

Use **blue** or **black** ink.

Before leaving the examination room you must give this booklet to the Invigilator; if you do not, you may lose all the marks for this paper.



\* X 7 5 7 7 6 0 1 0 1 \*

The questions for Section 1 are contained in the question paper X757/76/02.

Read these and record your answers on the answer grid on *Page 03* opposite.

Use **blue** or **black** ink. Do NOT use gel pens or pencil.

1. The answer to each question is **either** A, B, C, D or E. Decide what your answer is, then fill in the appropriate bubble (see sample question below).
2. There is **only one correct** answer to each question.
3. Any rough work must be written in the additional space for answers and rough work at the end of this booklet.

### Sample Question

The energy unit measured by the electricity meter in your home is the:

- A ampere
- B kilowatt-hour
- C watt
- D coulomb
- E volt.

The correct answer is **B** — kilowatt-hour. The answer **B** bubble has been clearly filled in (see below).

<b>A</b>	<b>B</b>	<b>C</b>	<b>D</b>	<b>E</b>
<input type="radio"/>	<input checked="" type="radio"/>	<input type="radio"/>	<input type="radio"/>	<input type="radio"/>

### Changing an answer

If you decide to change your answer, cancel your first answer by putting a cross through it (see below) and fill in the answer you want. The answer below has been changed to **D**.

<b>A</b>	<b>B</b>	<b>C</b>	<b>D</b>	<b>E</b>
<input type="radio"/>	<input checked="" type="radio"/>	<input type="radio"/>	<input checked="" type="radio"/>	<input type="radio"/>

If you then decide to change back to an answer you have already scored out, put a tick (✓) to the **right** of the answer you want, as shown below:

<b>A</b>	<b>B</b>	<b>C</b>	<b>D</b>	<b>E</b>	or	<b>A</b>	<b>B</b>	<b>C</b>	<b>D</b>	<b>E</b>
<input type="radio"/>	<input checked="" type="radio"/>	<input type="radio"/>	<input checked="" type="radio"/>	<input type="radio"/>		<input type="radio"/>	<input checked="" type="radio"/>	<input type="radio"/>	<input type="radio"/>	<input type="radio"/>



SECTION 1 — Answer Grid



	A	B	C	D	E
1	<input type="radio"/>	<input type="radio"/>	<input type="radio"/>	<input type="radio"/>	<input type="radio"/>
2	<input type="radio"/>	<input type="radio"/>	<input type="radio"/>	<input type="radio"/>	<input type="radio"/>
3	<input type="radio"/>	<input type="radio"/>	<input type="radio"/>	<input type="radio"/>	<input type="radio"/>
4	<input type="radio"/>	<input type="radio"/>	<input type="radio"/>	<input type="radio"/>	<input type="radio"/>
5	<input type="radio"/>	<input type="radio"/>	<input type="radio"/>	<input type="radio"/>	<input type="radio"/>
6	<input type="radio"/>	<input type="radio"/>	<input type="radio"/>	<input type="radio"/>	<input type="radio"/>
7	<input type="radio"/>	<input type="radio"/>	<input type="radio"/>	<input type="radio"/>	<input type="radio"/>
8	<input type="radio"/>	<input type="radio"/>	<input type="radio"/>	<input type="radio"/>	<input type="radio"/>
9	<input type="radio"/>	<input type="radio"/>	<input type="radio"/>	<input type="radio"/>	<input type="radio"/>
10	<input type="radio"/>	<input type="radio"/>	<input type="radio"/>	<input type="radio"/>	<input type="radio"/>
11	<input type="radio"/>	<input type="radio"/>	<input type="radio"/>	<input type="radio"/>	<input type="radio"/>
12	<input type="radio"/>	<input type="radio"/>	<input type="radio"/>	<input type="radio"/>	<input type="radio"/>
13	<input type="radio"/>	<input type="radio"/>	<input type="radio"/>	<input type="radio"/>	<input type="radio"/>
14	<input type="radio"/>	<input type="radio"/>	<input type="radio"/>	<input type="radio"/>	<input type="radio"/>
15	<input type="radio"/>	<input type="radio"/>	<input type="radio"/>	<input type="radio"/>	<input type="radio"/>
16	<input type="radio"/>	<input type="radio"/>	<input type="radio"/>	<input type="radio"/>	<input type="radio"/>
17	<input type="radio"/>	<input type="radio"/>	<input type="radio"/>	<input type="radio"/>	<input type="radio"/>
18	<input type="radio"/>	<input type="radio"/>	<input type="radio"/>	<input type="radio"/>	<input type="radio"/>
19	<input type="radio"/>	<input type="radio"/>	<input type="radio"/>	<input type="radio"/>	<input type="radio"/>
20	<input type="radio"/>	<input type="radio"/>	<input type="radio"/>	<input type="radio"/>	<input type="radio"/>



[BLANK PAGE]

DO NOT WRITE ON THIS PAGE



\* X 7 5 7 7 6 0 1 0 4 \*

[Turn over for SECTION 2

DO NOT WRITE ON THIS PAGE



\* X 7 5 7 7 6 0 1 0 5 \*

SECTION 2 — 110 marks  
Attempt ALL questions

1. A student is on a stationary train.  
The train now accelerates along a straight level track.  
The student uses an app on a phone to measure the acceleration of the train.



- (a) The train accelerates uniformly at  $0.32 \text{ m s}^{-2}$  for 25 seconds.
- (i) State what is meant by *an acceleration of  $0.32 \text{ m s}^{-2}$* . 1
- (ii) Calculate the distance travelled by the train in the 25 seconds. 3  
*Space for working and answer*



1. (continued)

MARKS

DO NOT  
WRITE IN  
THIS  
MARGIN

- (b) Later in the journey, the train is travelling at a constant speed as it approaches a bridge.

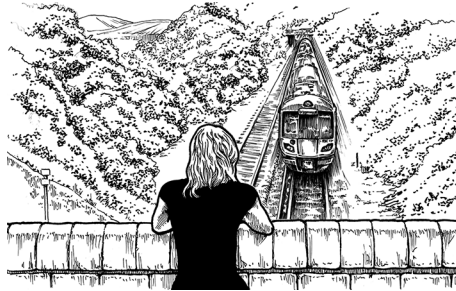

A horn on the train emits sound of frequency 270 Hz.

The frequency of the sound heard by a person standing on the bridge is 290 Hz.

The speed of sound in air is  $340 \text{ m s}^{-1}$ .

- (i) Calculate the speed of the train.

3

*Space for working and answer*

- (ii) The train continues to sound its horn as it passes under the bridge.

Explain why the frequency of the sound heard by the person standing on the bridge decreases as the train passes under the bridge and then moves away.

You may wish to use a diagram.

1



\* X 7 5 7 7 6 0 1 0 7 \*

2. A white snooker ball and a black snooker ball travel towards each other in a straight line.

The white ball and the black ball each have a mass of  $0.180 \text{ kg}$ .

Just before the balls collide head-on, the white ball is travelling at  $2.60 \text{ m s}^{-1}$  to the right and the black ball is travelling at  $1.80 \text{ m s}^{-1}$  to the left.



After the collision, the black ball rebounds with a velocity of  $2.38 \text{ m s}^{-1}$  to the right.

- (a) (i) Determine the velocity of the white ball immediately after the collision. 3

*Space for working and answer*

- (ii) The collision between the balls is inelastic.

State what is meant by an *inelastic collision*. 1



2. (continued)

MARKS  
DO NOT  
WRITE IN  
THIS  
MARGIN

- (b) A student carries out an experiment to measure the average force exerted by a cue on a ball.

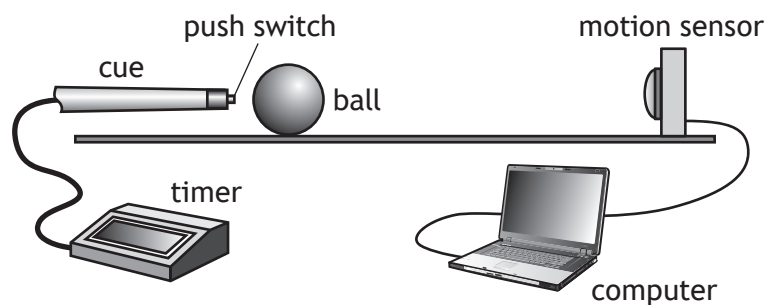

The cue hits the stationary ball.

The timer records the time the cue is in contact with the ball.

The computer displays the speed of the ball.

The results are shown.

Time of contact between the cue and the ball =  $(0.040 \pm 0.001)$  s

Speed of the ball immediately after contact =  $(0.84 \pm 0.01)$  m s<sup>-1</sup>

Mass of the ball =  $(0.180 \pm 0.001)$  kg

- (i) Calculate the average force exerted on the ball by the cue.  
An uncertainty in this value is not required.

3

*Space for working and answer*

- (ii) Determine the percentage uncertainty in the value for the average force on the ball.

2

*Space for working and answer*



3. A ball is thrown vertically upwards.  
The ball is above the ground when released.

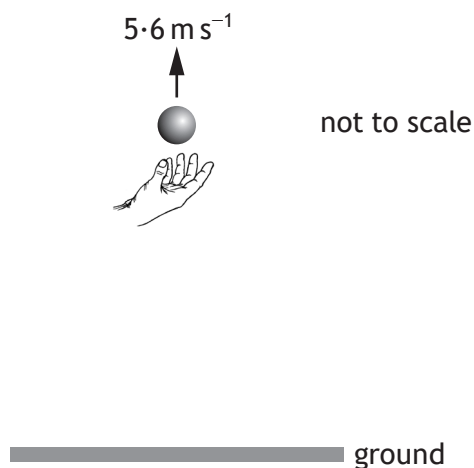

The graph shows how the vertical velocity of the ball varies with time from the instant it is released until just before it hits the ground.

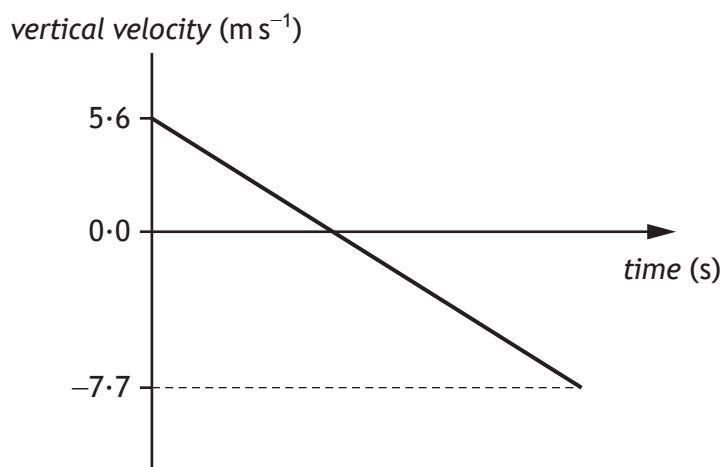

The effects of air resistance can be ignored.

- (a) (i) Calculate the time taken for the ball to reach its maximum height. 3  
*Space for working and answer*



3. (a) (continued)

- (ii) Calculate the distance the ball falls from its maximum height to the ground.

3

*Space for working and answer*

- (b) The ball is now thrown vertically upwards from the same height with a greater initial vertical velocity.

Add a line to the graph below to show how the vertical velocity of the ball varies with time from the instant it is released until just before it hits the ground.

The effects of air resistance can be ignored.

Additional numerical values on the axes are not required.

3

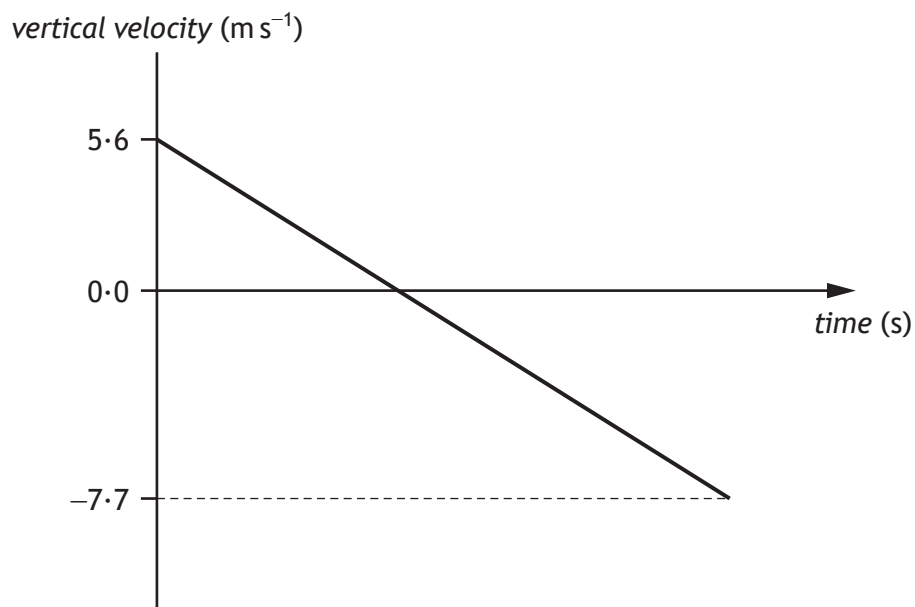

(An additional graph, if required, can be found on Page 39.)



4. Some motorways have variable speed limits, with overhead information boards displaying the maximum speed allowed. This system is designed to keep the traffic flowing and to avoid congestion.



In this system, the flow of traffic is observed and the maximum speed to be displayed is determined using

$$speed = frequency \times wavelength$$

Use your knowledge of physics to comment on this system for determining the maximum speed to be displayed.

3



MARKS

DO NOT  
WRITE IN  
THIS  
MARGIN

4. (continued)



\* X 7 5 7 7 6 0 1 1 3 \*

5. Planets outside our solar system are called exoplanets.  
 An exoplanet of mass  $5.69 \times 10^{27}$  kg orbits a star of mass  $3.83 \times 10^{30}$  kg.

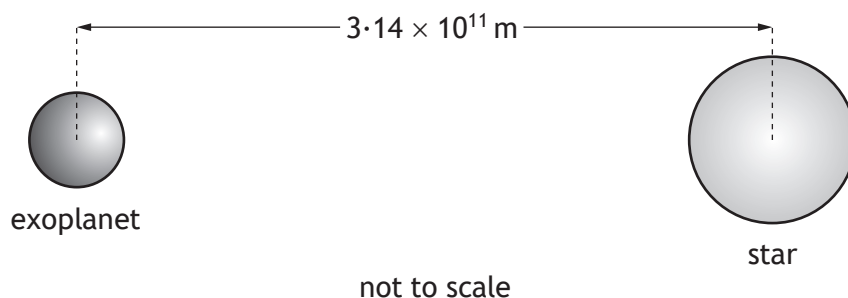

- (a) (i) Compare the mass of the star with the mass of the exoplanet in terms of orders of magnitude.  
*Space for working and answer*

2

- (ii) The distance between the exoplanet and the star is  $3.14 \times 10^{11}$  m.  
 Calculate the gravitational force between the star and the exoplanet.  
*Space for working and answer*

3



5. (continued)

MARKS  
DO NOT  
WRITE IN  
THIS  
MARGIN

- (b) The gravitational force between the star and the exoplanet causes the star to follow a circular path as the exoplanet orbits the star. Small differences in the wavelength of the light from the star are observed on Earth.

Light from the star is redshifted when the star moves away from the Earth and blueshifted when the star moves towards the Earth.

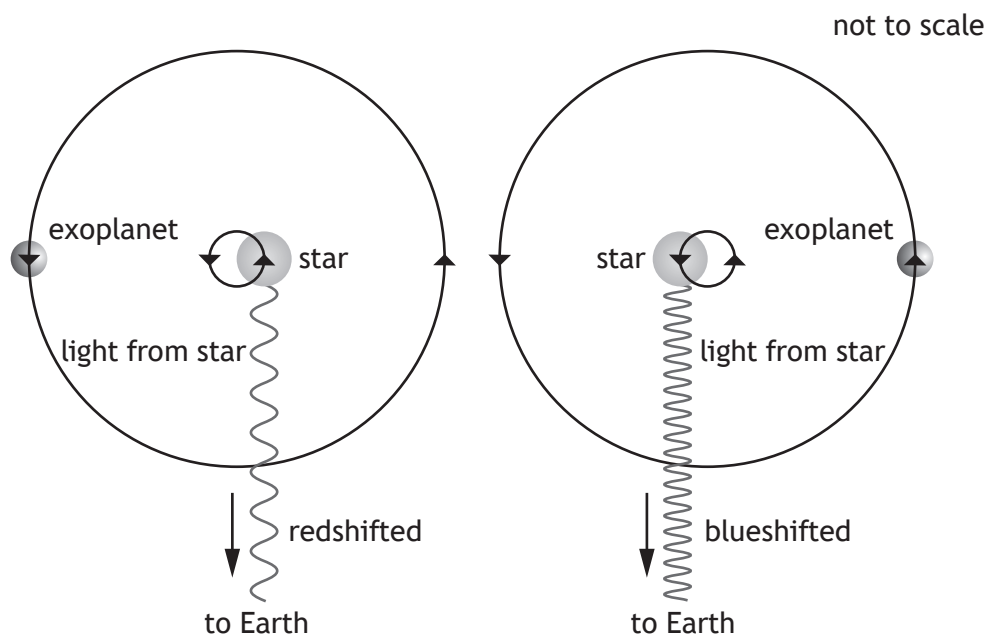

- (i) Calculate the redshift of light from the star observed on Earth when the star is moving away from the Earth at  $6.60 \times 10^3 \text{ m s}^{-1}$ .

3

*Space for working and answer*

- (ii) For an exoplanet of greater mass at the same distance from the star, suggest whether the radius of the circular path followed by the star would be greater than, less than, or the same as that for an exoplanet of smaller mass.

1



\* X 7 5 7 7 6 0 1 1 5 \*

6. The visible spectrum of light emitted by a star is observed to contain a number of dark lines. The dark lines occur because certain wavelengths of light are absorbed when light passes through atoms in the star's outer atmosphere.

The diagram shows some of the energy levels for a hydrogen atom.

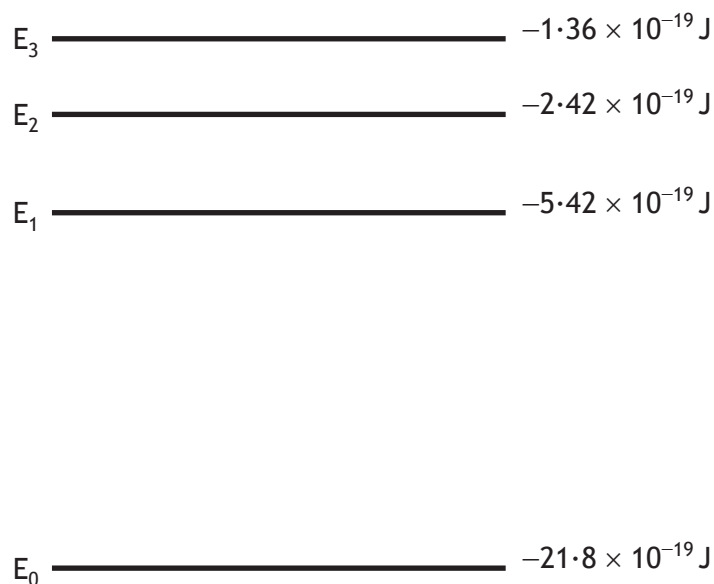

- (a) For the energy levels shown in the diagram, identify the electron transition that would lead to the absorption of a photon with the highest frequency.

1

- (b) An electron makes the transition from energy level E<sub>1</sub> to E<sub>3</sub>. Determine the frequency of the photon absorbed.

3

*Space for working and answer*



\* X 7 5 7 7 6 0 1 1 6 \*

[Turn over for next question

DO NOT WRITE ON THIS PAGE



\* X 7 5 7 7 6 0 1 1 7 \*

7. The following diagram gives information on the Standard Model of fundamental particles.

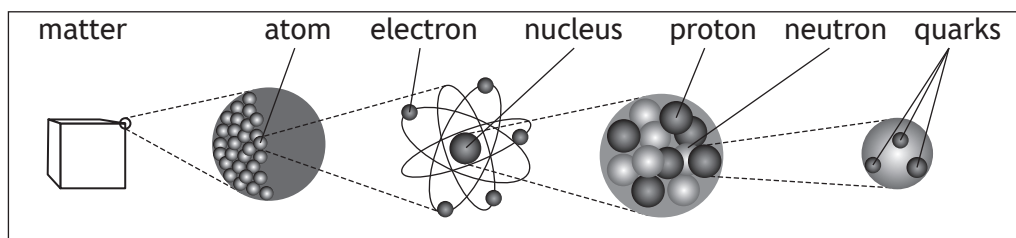

(a) Explain why the proton and the neutron are **not** fundamental particles. 1

(b) An extract from a data book contains the following information about three types of sigma ( $\Sigma$ ) particles. Sigma particles are made up of three quarks.

Particle	Symbol	Quark Content	Charge	Mean lifetime (s)
sigma plus	$\Sigma^+$	up up strange	$+1e$	$8.0 \times 10^{-11}$
neutral sigma	$\Sigma^0$	up down strange	0	$7.4 \times 10^{-20}$
sigma minus	$\Sigma^-$	down down strange	$-1e$	$1.5 \times 10^{-10}$

(i) A student makes the following statement.  
*All baryons are hadrons, but not all hadrons are baryons.*  
 Explain why this statement is correct. 2

(ii) The charge on an up quark is  $+\frac{2}{3}e$ .  
 Determine the charge on a strange quark. 1  
*Space for working and answer*



7. (continued)

(c) (i) State the name of the force that holds the quarks together in the sigma ( $\Sigma$ ) particle. 1

(ii) State the name of the boson associated with this force. 1

(d) Sigma minus ( $\Sigma^-$ ) particles have a mean lifetime of  $1.5 \times 10^{-10}$  s in their frame of reference. 3

$\Sigma^-$  are produced in a particle accelerator and travel at a speed of  $0.9c$  relative to a stationary observer.

Calculate the mean lifetime of the  $\Sigma^-$  particle as measured by this observer.

*Space for working and answer*



8. X-ray machines are used in hospitals.

An X-ray machine contains a linear accelerator that is used to accelerate electrons towards a metal target.

The linear accelerator consists of hollow metal tubes placed in a vacuum.

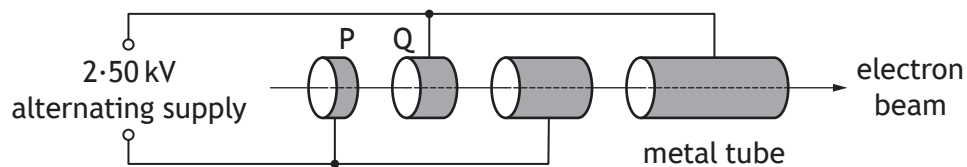

Electrons are accelerated across the gaps between the tubes by an alternating supply.

(a) (i) Calculate the work done on an electron as it accelerates from P to Q. 3  
*Space for working and answer*

(ii) Explain why an alternating supply is used in the linear accelerator. 1



8. (continued)

- (b) The electron beam is then passed into a “slalom magnet” beam guide. The function of the beam guide is to direct the electrons towards a metal target.

Inside the beam guides R and S, two different magnetic fields act on the electrons.

Electrons strike the metal target to produce high energy photons of radiation.

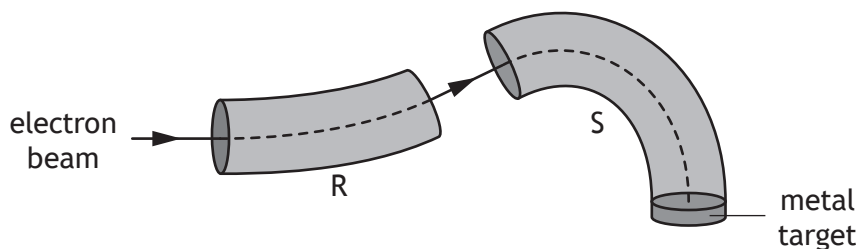

- (i) Determine the direction of the magnetic field inside beam guide R. 1
- (ii) State two differences between the magnetic fields inside beam guides R and S. 2
- (c) Calculate the minimum speed of an electron that will produce a photon of energy  $4.16 \times 10^{-17}$  J. 3
- Space for working and answer*



9. A diagram from a 'How Things Work' website contains information about a nuclear fusion reaction.

Reaction of helium-3 with deuterium

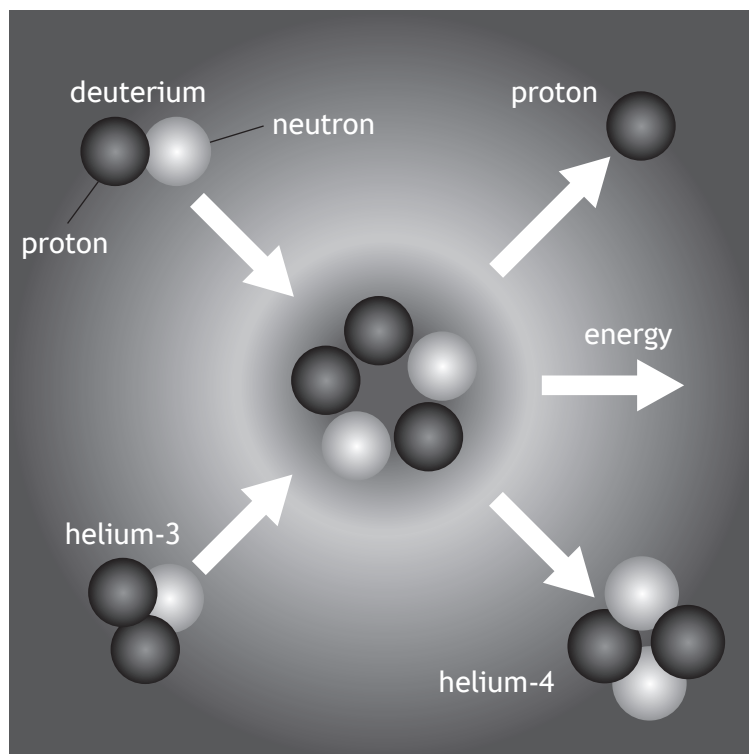

- (a) State what is meant by the term *nuclear fusion*.

1



9. (continued)

(b) The following statement represents this fusion reaction.

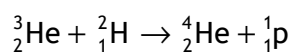

The mass of the particles involved in the reaction are shown in the table.

Particle	Mass (kg)
${}^3_2\text{He}$	$5.008 \times 10^{-27}$
${}^2_1\text{H}$	$3.344 \times 10^{-27}$
${}^4_2\text{He}$	$6.646 \times 10^{-27}$
${}^1_1\text{p}$	$1.673 \times 10^{-27}$

(i) Explain why energy is released in this reaction.

1

(ii) Determine the energy released in this reaction.

4

*Space for working and answer*



10. An experiment is carried out to determine the wavelength of light from a laser.

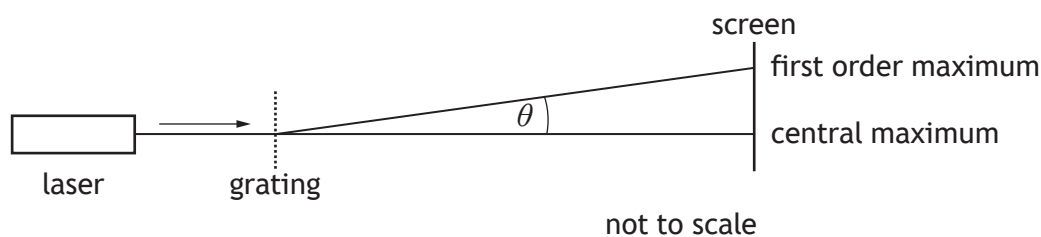

- (a) Explain, in terms of waves, how a maximum is formed.

1

- (b) The experiment is carried out with four gratings.

The separation of the slits  $d$  is different for each grating.

The angle between the central maximum and the first order maximum  $\theta$ , produced by each grating, is measured.

The results are used to produce a graph of  $\sin\theta$  against  $\frac{1}{d}$ .

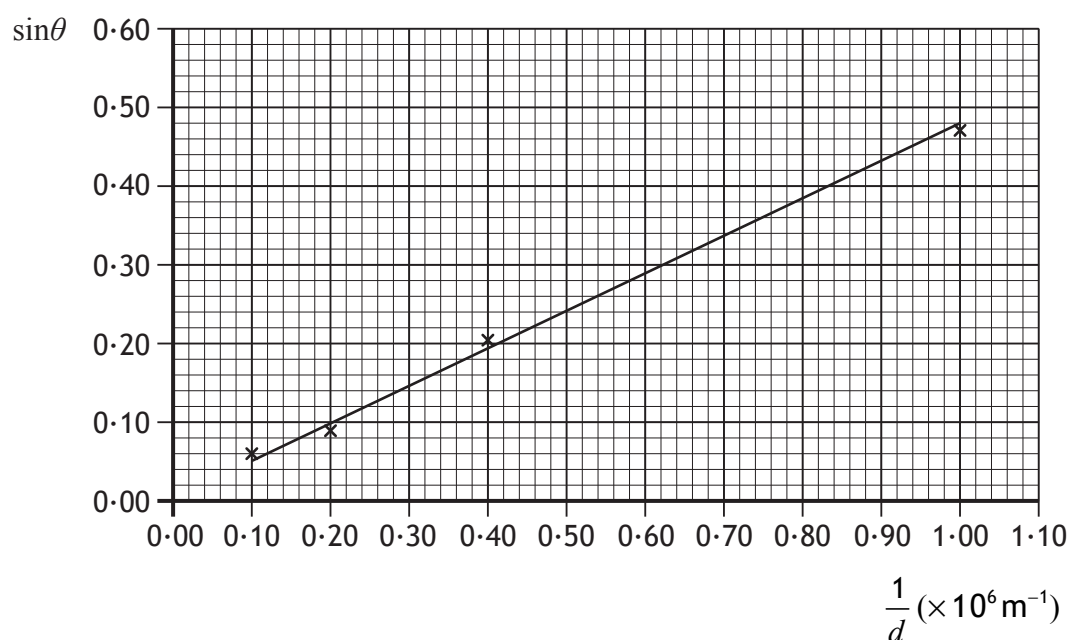

10. (b) (continued)

- (i) Determine the wavelength of the light from the laser used in this experiment.

3

*Space for working and answer*

- (ii) Determine the angle  $\theta$  produced when a grating with a spacing  $d$  of  $2.0 \times 10^{-6}$  m is used with this laser.

3

*Space for working and answer*

- (c) Suggest two improvements that could be made to the experiment to improve reliability.

2



\* X 7 5 7 7 6 0 1 2 5 \*

11. The use of analogies from everyday life can help better understanding of physics concepts. A car moving from a smooth surface to a rough surface, eg from a road to sand, can be used as an analogy for the refraction of light.

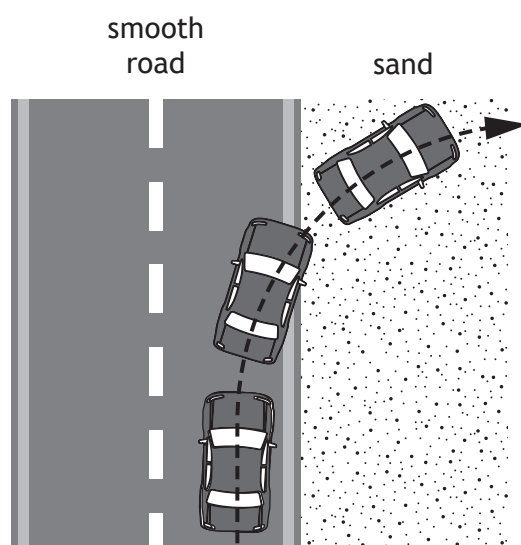

Use your knowledge of physics to comment on this analogy.

3



[Turn over for next question

DO NOT WRITE ON THIS PAGE



\* X 7 5 7 7 6 0 1 2 7 \*

12. A lamp is connected to a battery containing two cells as shown.

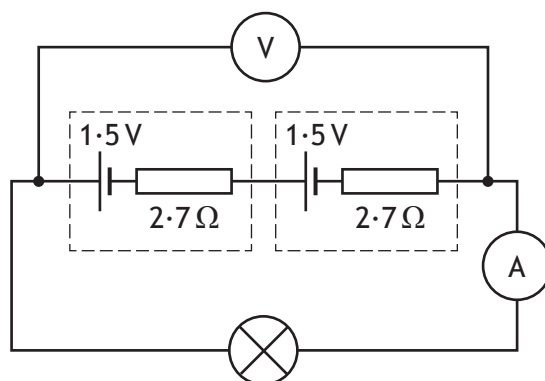

The e.m.f. of each cell is 1.5 V and the internal resistance of each cell is 2.7 Ω.

The reading on the ammeter is 64 mA.

(a) State what is meant by *an e.m.f. of 1.5 V*. 1

(b) (i) Show that the lost volts in the battery is 0.35 V. 2  
*Space for working and answer*

(ii) Determine the reading on the voltmeter. 1  
*Space for working and answer*

(iii) Calculate the power dissipated by the lamp. 3  
*Space for working and answer*



12. (continued)

(c) In a different circuit, an LED is connected to a battery containing four cells.

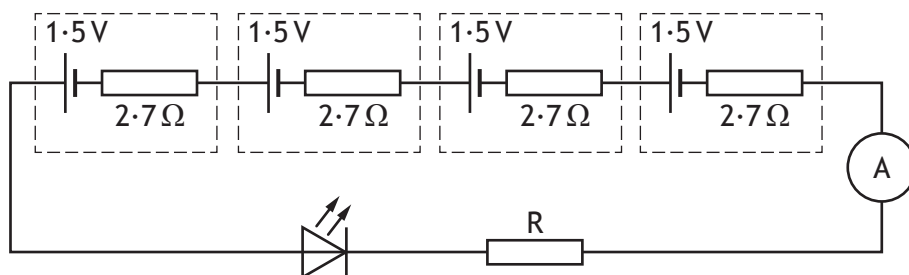

The potential difference across the LED is  $3.6\text{ V}$  when the current is  $26\text{ mA}$ .

Determine the resistance of resistor R.

4

*Space for working and answer*



[BLANK PAGE]

DO NOT WRITE ON THIS PAGE



\* X 7 5 7 7 6 0 1 3 0 \*

13. An uncharged  $220\ \mu\text{F}$  capacitor is connected in a circuit as shown.

MARKS  
DO NOT  
WRITE IN  
THIS  
MARGIN

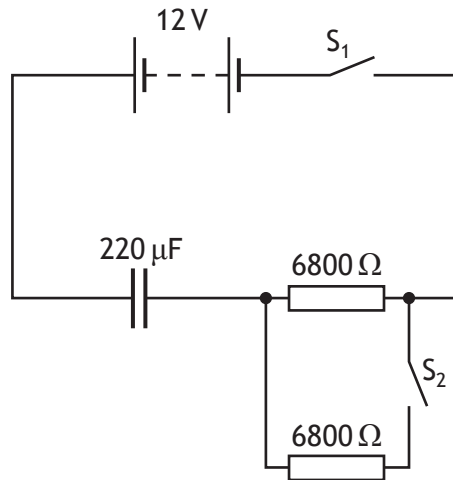

The 12 V battery has negligible internal resistance.

(a) Switch  $S_1$  is closed and the capacitor charges in a time of 7.5 s.

Calculate the initial charging current.

3

*Space for working and answer*

(b) Switch  $S_1$  is opened.

The capacitor is discharged.

Switch  $S_2$  is now closed and then switch  $S_1$  is closed.

Explain why the time for the capacitor to fully charge is less than in part (a).

2



14. Solar cells are made by joining n-type and p-type semiconductor materials. A layer is formed at the junction between the materials.

(a) A potential difference is produced when photons enter the layer between the p-type and n-type materials.

State the name of this effect.

1

(b) A student carries out an experiment using a solar cell connected to a variable resistor R as shown.

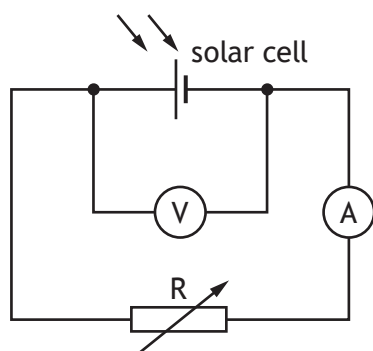

A lamp is placed above the solar cell and switched on.

The variable resistor is altered and readings of current and voltage are taken. These readings are used to produce the following graph.

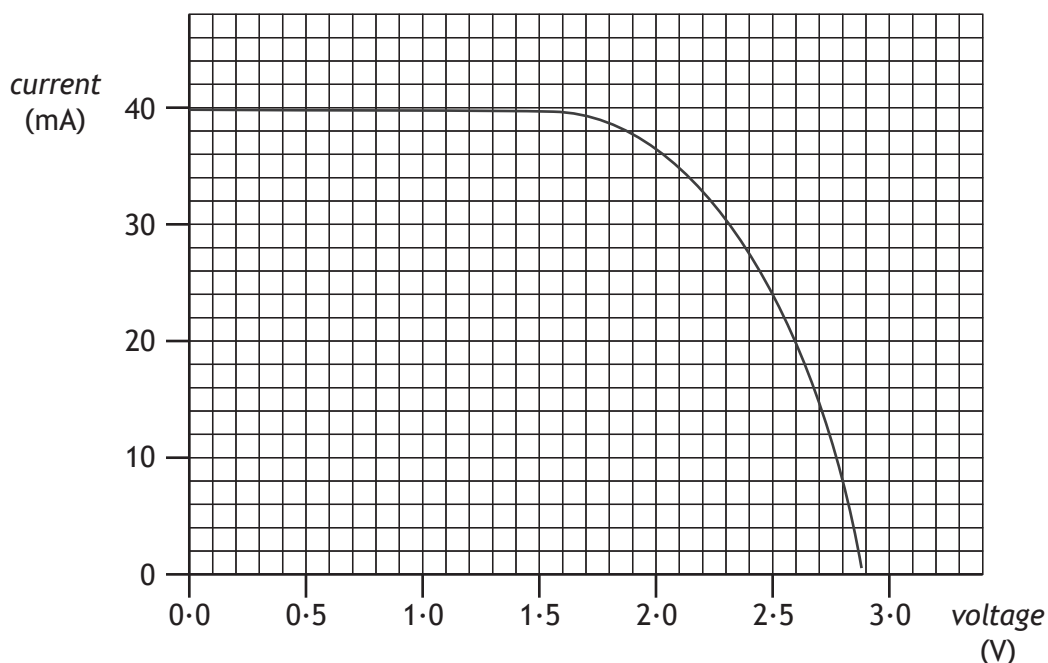

14. (b) (continued)

- (i) Solar cells have a maximum power output for a particular irradiance of light.

In this experiment, the maximum power output occurs when the voltage is 2.1 V.

Use information from the graph to estimate a value for the maximum power output from the solar cell.

3

*Space for working and answer*

- (ii) The lamp is now moved closer to the solar cell.

Explain, in terms of photons, why the maximum output power from the solar cell increases.

1



\* X 7 5 7 7 6 0 1 3 3 \*

15. A wire of length  $L$  and cross-sectional area  $A$  is shown.

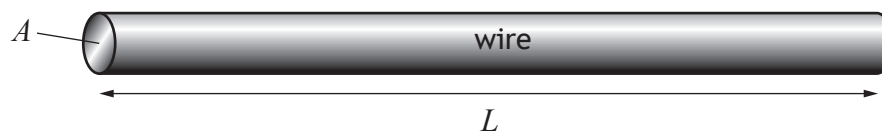

The resistance  $R$  of the wire is given by the relationship

$$R = \frac{\rho L}{A}$$

where  $\rho$  is the resistivity of the wire in  $\Omega \text{ m}$ .

(a) The resistivity of aluminium is  $2.8 \times 10^{-8} \Omega \text{ m}$ .

Calculate the resistance of an aluminium wire of length  $0.82 \text{ m}$  and cross-sectional area  $4.0 \times 10^{-6} \text{ m}^2$ .

2

*Space for working and answer*



15. (continued)

MARKS

DO NOT  
WRITE IN  
THIS  
MARGIN

- (b) A student carries out an investigation to determine the resistivity of a cylindrical metal wire of cross-sectional area  $4.52 \times 10^{-6} \text{ m}^2$ .



The student varies the length  $L$  of the wire and measures the corresponding resistance  $R$  of the wire.

The results are shown in the table.

Length of wire $L$ (m)	Resistance of wire $R$ ( $\times 10^{-3} \Omega$ )
1.5	5.6
2.0	7.5
2.5	9.4
3.0	11.2
3.5	13.2

- (i) Using the square-ruled paper on *Page 36*, draw a graph of  $R$  against  $L$ . 3
- (ii) Calculate the gradient of your graph. 2  
*Space for working and answer*
- (iii) Determine the resistivity of the metal wire. 3  
*Space for working and answer*

[END OF QUESTION PAPER]



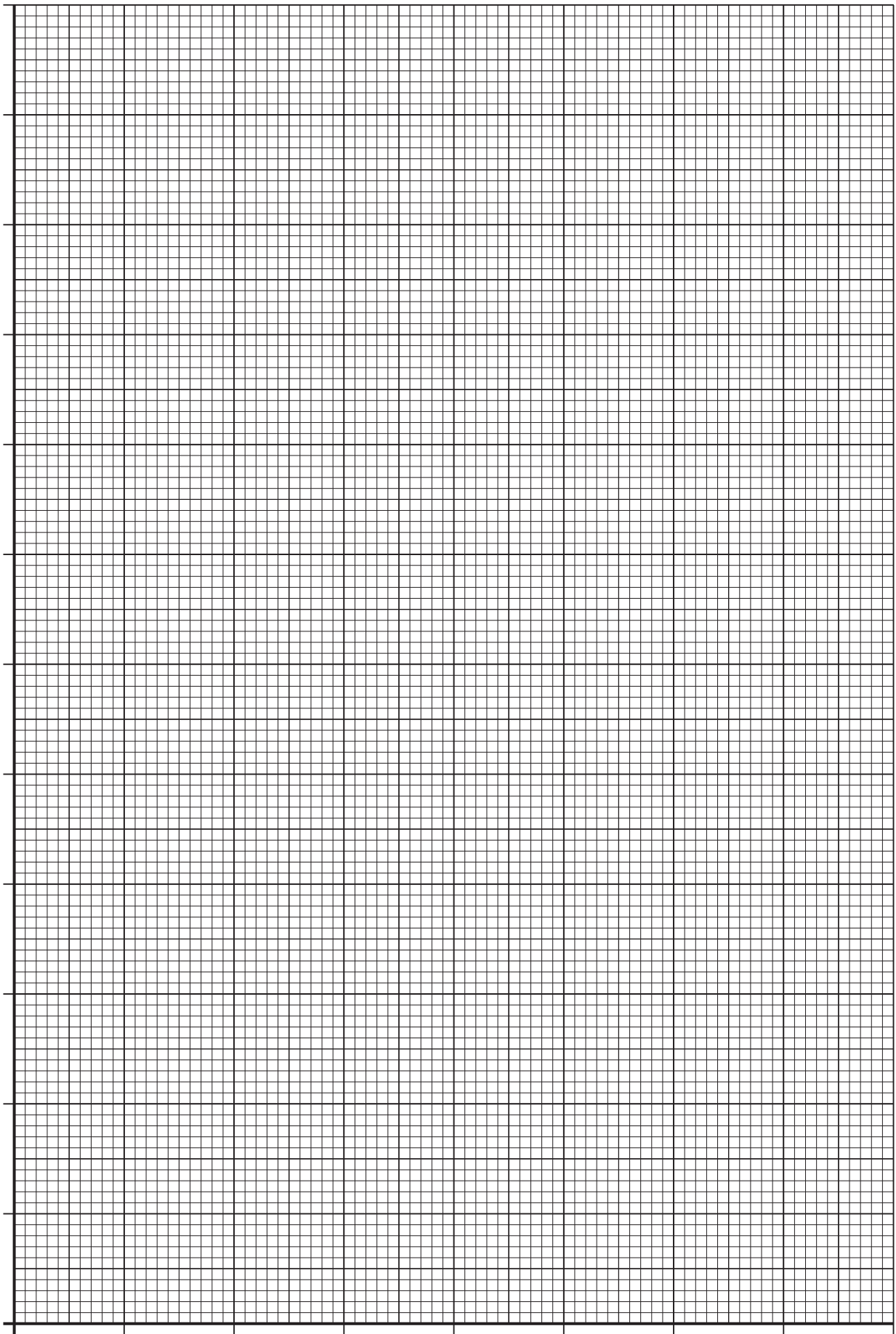

\* X 7 5 7 7 6 0 1 3 6 \*

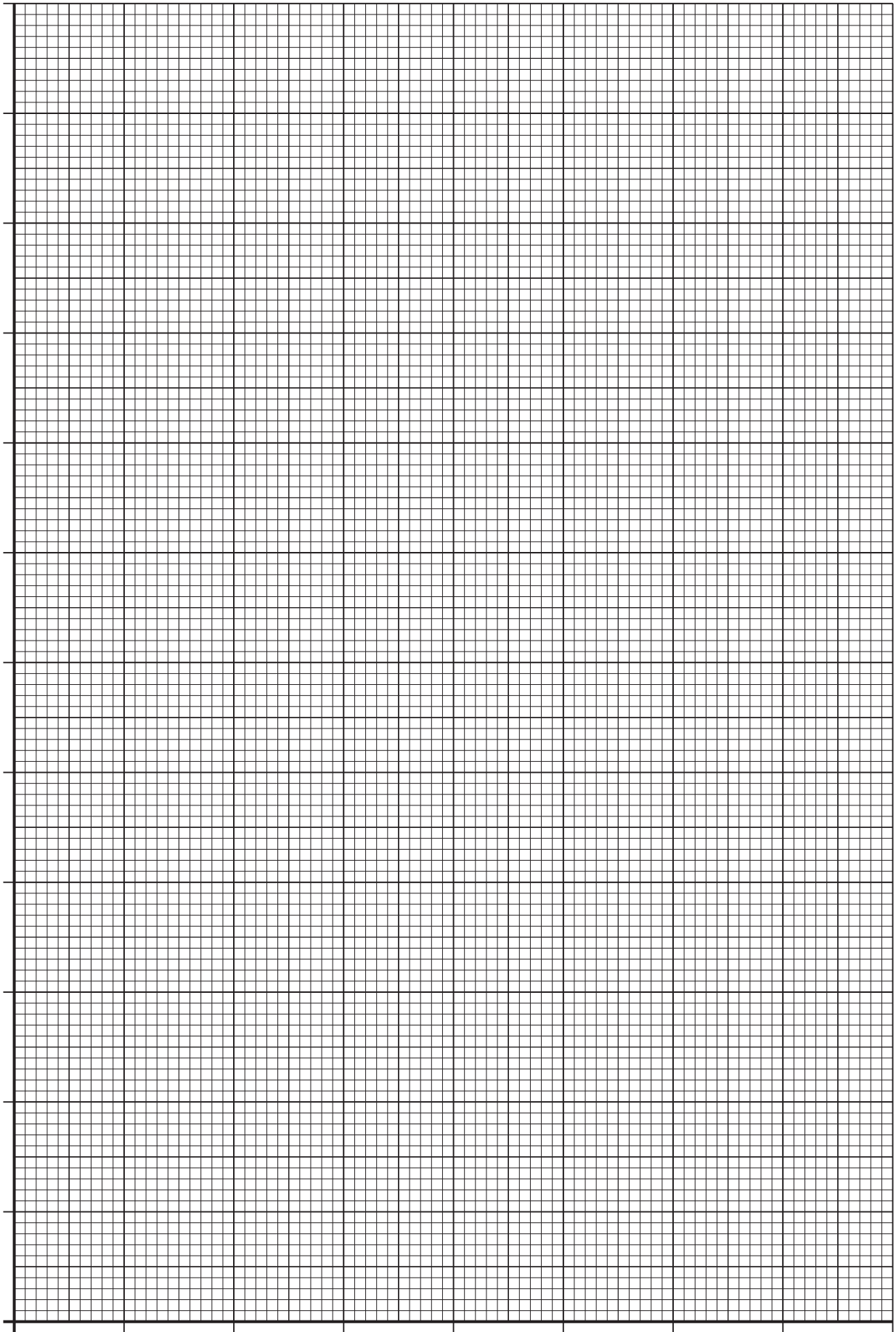

\* X 7 5 7 7 6 0 1 3 7 \*

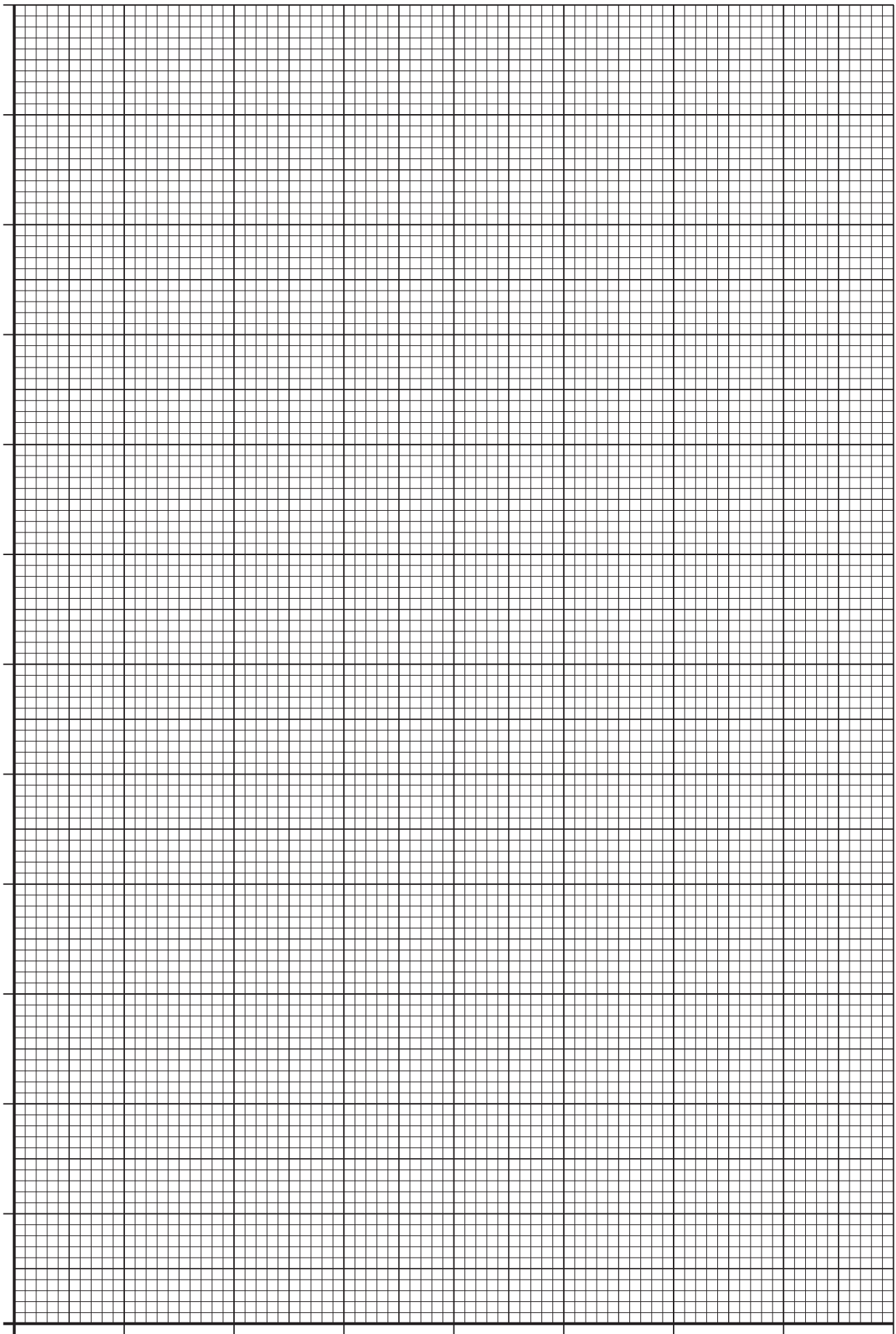

\* X 7 5 7 7 6 0 1 3 8 \*

ADDITIONAL SPACE FOR ANSWERS AND ROUGH WORK

MARKS  
DO NOT  
WRITE IN  
THIS  
MARGIN

Additional graph for use with Question 3 (b)

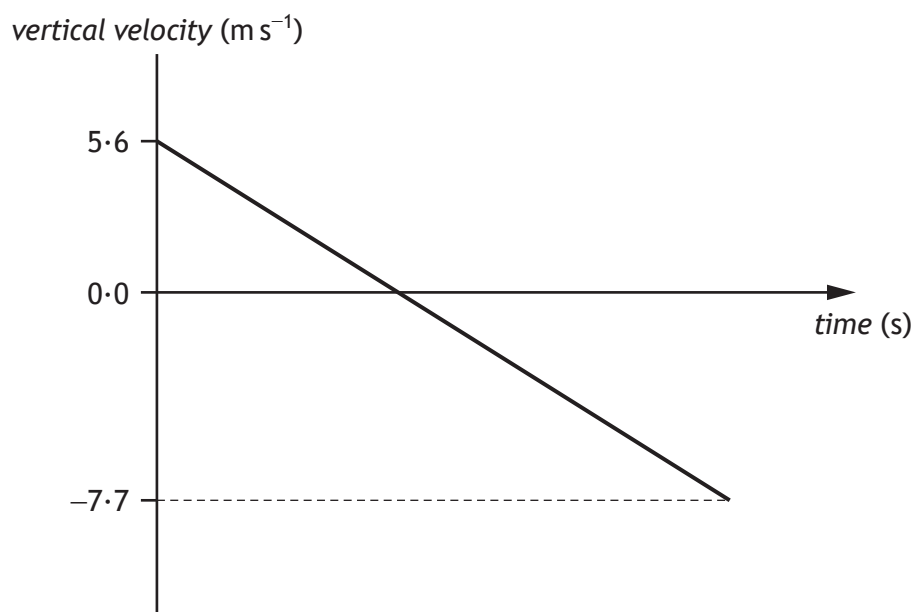

ADDITIONAL SPACE FOR ANSWERS AND ROUGH WORK

MARKS

DO NOT  
WRITE IN  
THIS  
MARGIN



\* X 7 5 7 7 6 0 1 4 0 \*

ADDITIONAL SPACE FOR ANSWERS AND ROUGH WORK

MARKS DO NOT  
WRITE IN  
THIS  
MARGIN



\* X 7 5 7 7 6 0 1 4 1 \*

[BLANK PAGE]

DO NOT WRITE ON THIS PAGE



\* X 7 5 7 7 6 0 1 4 2 \*

[BLANK PAGE]

DO NOT WRITE ON THIS PAGE



\* X 7 5 7 7 6 0 1 4 3 \*

[BLANK PAGE]

DO NOT WRITE ON THIS PAGE

*Acknowledgement of Copyright*

Question 1 KieferPix/shutterstock.com

Question 4 Editorial Credit: Flik47/shutterstock.com



\* X 7 5 7 7 6 0 1 4 4 \*