

FOR OFFICIAL USE



--	--	--	--	--	--

National  
Qualifications  
2019

Mark

--

**X857/76/01**

**Physics  
Paper 2**

WEDNESDAY, 15 MAY

10:15 AM – 12:30 PM



\* X 8 5 7 7 6 0 1 \*

Fill in these boxes and read what is printed below.

Full name of centre

--

Town

--

Forename(s)

--

Surname

--

Number of seat

--

Date of birth

Day

--	--

Month

--	--

Year

--	--

Scottish candidate number

--	--	--	--	--	--	--	--	--	--

**Total marks — 130**

Attempt ALL questions.

**You may use a calculator.**

Reference may be made to the data sheet on *page 02* of this booklet and to the relationships sheet X857/76/11.

Care should be taken to give an appropriate number of significant figures in the final answers to calculations.

Write your answers clearly in the spaces provided in this booklet. Additional space for answers and rough work is provided at the end of this booklet. If you use this space you must clearly identify the question number you are attempting. Any rough work must be written in this booklet. Score through your rough work when you have written your final copy.

Use **blue** or **black** ink.

Before leaving the examination room you must give this booklet to the Invigilator; if you do not, you may lose all the marks for this paper.



\* X 8 5 7 7 6 0 1 0 1 \*

## DATA SHEET

### COMMON PHYSICAL QUANTITIES

Quantity	Symbol	Value	Quantity	Symbol	Value
Speed of light in vacuum	$c$	$3.00 \times 10^8 \text{ m s}^{-1}$	Planck's constant	$h$	$6.63 \times 10^{-34} \text{ J s}$
Magnitude of the charge on an electron	$e$	$1.60 \times 10^{-19} \text{ C}$	Mass of electron	$m_e$	$9.11 \times 10^{-31} \text{ kg}$
Universal Constant of Gravitation	$G$	$6.67 \times 10^{-11} \text{ m}^3 \text{ kg}^{-1} \text{ s}^{-2}$	Mass of neutron	$m_n$	$1.675 \times 10^{-27} \text{ kg}$
Gravitational acceleration on Earth	$g$	$9.8 \text{ m s}^{-2}$	Mass of proton	$m_p$	$1.673 \times 10^{-27} \text{ kg}$
Hubble's constant	$H_0$	$2.3 \times 10^{-18} \text{ s}^{-1}$			

### REFRACTIVE INDICES

The refractive indices refer to sodium light of wavelength 589 nm and to substances at a temperature of 273 K.

Substance	Refractive index	Substance	Refractive index
Diamond	2.42	Water	1.33
Crown glass	1.50	Air	1.00

### SPECTRAL LINES

Element	Wavelength/nm	Colour	Element	Wavelength/nm	Colour
Hydrogen	656	Red	Cadmium	644	Red
	486	Blue-green		509	Green
	434	Blue-violet		480	Blue
	410	Violet	Lasers		
	397	Ultraviolet	<i>Element</i>	<i>Wavelength/nm</i>	<i>Colour</i>
	389	Ultraviolet	Carbon dioxide	9550 } 10590 }	Infrared
Sodium	589	Yellow	Helium-neon	633	Red

### PROPERTIES OF SELECTED MATERIALS

Substance	Density/kg m <sup>-3</sup>	Melting point/K	Boiling point/K
Aluminium	$2.70 \times 10^3$	933	2623
Copper	$8.96 \times 10^3$	1357	2853
Ice	$9.20 \times 10^2$	273	....
Sea Water	$1.02 \times 10^3$	264	377
Water	$1.00 \times 10^3$	273	373
Air	1.29	....	....
Hydrogen	$9.0 \times 10^{-2}$	14	20

The gas densities refer to a temperature of 273 K and a pressure of  $1.01 \times 10^5 \text{ Pa}$ .



\* X 8 5 7 7 6 0 1 0 2 \*

[Turn over for next question

DO NOT WRITE ON THIS PAGE



\* X 8 5 7 7 6 0 1 0 3 \*

Total marks — 130  
Attempt ALL questions

1. A student carries out an experiment with a tennis ball and a motion sensor connected to a laptop.

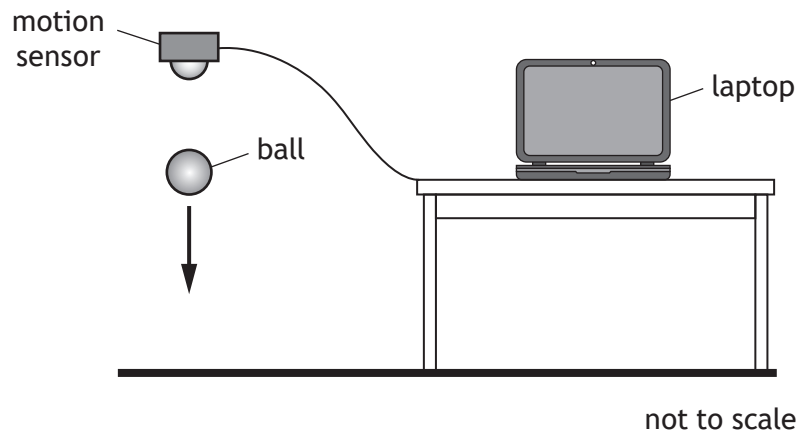

The ball is released from rest below the sensor.

The graph shows how the vertical velocity  $v$  of the ball varies with time  $t$ , from the moment the ball is released until it rebounds to its new maximum height.

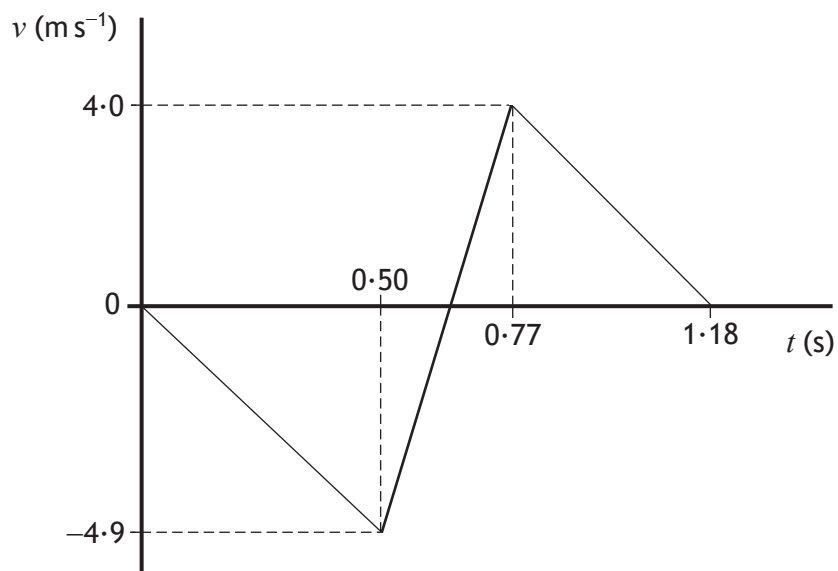

MARKS

DO NOT  
WRITE IN  
THIS  
MARGIN

1. (continued)

(a) Using information from the graph

(i) show that the initial acceleration of the ball is  $-9.8 \text{ m s}^{-2}$

2

*Space for working and answer*

(ii) determine the height from which the ball is released.

3

*Space for working and answer*



\* X 8 5 7 7 6 0 1 0 5 \*

1. (continued)

(b) The mass of the ball is 57.0 g.

- (i) Determine the magnitude of the change in momentum of the ball during the bounce.

3

*Space for working and answer*

- (ii) Determine the magnitude of the average force exerted by the ball on the ground during the bounce.

3

*Space for working and answer*



\* X 8 5 7 7 6 0 1 0 6 \*

1. (continued)

- (c) Complete the sketch graph of acceleration  $a$  against time  $t$  for the ball, between 0 s and 1.18 s after it is released.

Numerical values are **not** required on the acceleration axis.

2

(An additional graph, if required, can be found on *page 44*)

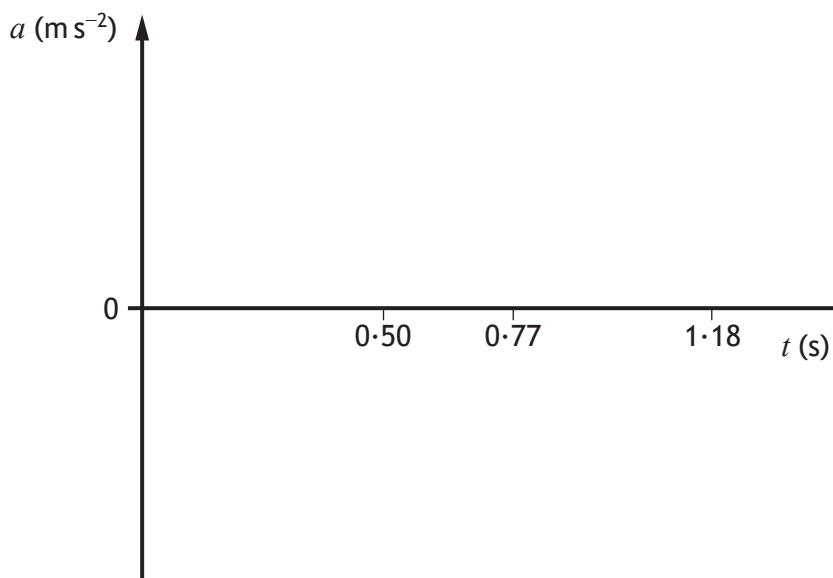

[Turn over



2. A student abseils down the outside of a building using a rope.

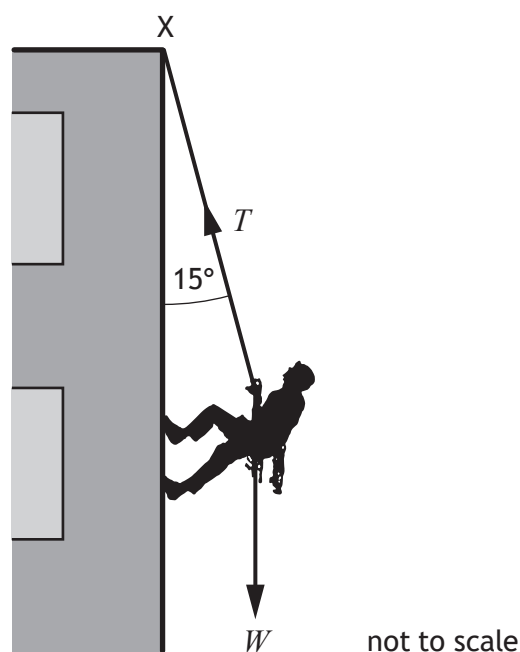

The mass of the student is 55 kg.

The rope, of negligible mass, is attached to a fixed point X at the top of the building.

The rope makes an angle of  $15^\circ$  to the building.

- (a) Calculate the weight  $W$  of the student.

3

*Space for working and answer*



2. (continued)

(b) Determine the tension  $T$  in the rope.

*Space for working and answer*

3

(c) As the student abseils down the building the angle the rope makes with the building decreases.

State whether the tension in the rope increases, decreases or stays the same.

Justify your answer.

2

[Turn over



\* X 8 5 7 7 6 0 1 0 9 \*

3. A footballer tells teammates that a football can be kicked a much greater distance when the ball is initially travelling towards them, compared to kicking a stationary ball.



Use your knowledge of physics to comment on this statement.

3



\* X 8 5 7 7 6 0 1 1 0 \*

DO NOT  
WRITE IN  
THIS  
MARGIN

3. (continued)

[Turn over



\* X 8 5 7 7 6 0 1 1 1 \*

4. A communications satellite orbits the Earth at a height of  $36.0 \times 10^6$  m above the surface of the Earth.

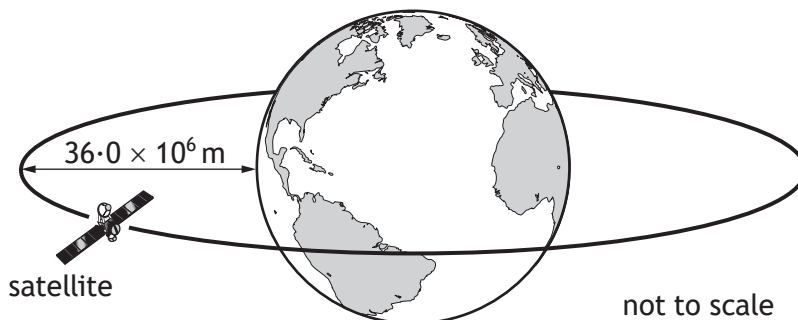

The mass of the Earth is  $6.0 \times 10^{24}$  kg and the radius of the Earth is  $6.4 \times 10^6$  m.

- (a) Determine the distance between the centre of the Earth and the satellite. 1

*Space for working and answer*

- (b) The gravitational force of attraction between the Earth and the satellite is 57 N.

Calculate the mass of the satellite. 3

*Space for working and answer*



\* X 8 5 7 7 6 0 1 1 2 \*

4. (continued)

- (c) Determine the value of the Earth's gravitational field strength  $g$  at the satellite.

3

*Space for working and answer*

- (d) A second satellite has a **quarter** of the mass of the first satellite.

The distance from the centre of the Earth to the second satellite is **half** the distance from the centre of the Earth to the first satellite.

State how the gravitational force of attraction between the second satellite and the Earth compares to the gravitational force of attraction between the first satellite and the Earth.

Justify your answer.

3



\* X 8 5 7 7 6 0 1 1 3 \*

5. (a) A person is standing at the side of a road. A car travels along the road towards the person, at a constant speed of  $12 \text{ m s}^{-1}$ . The car emits a sound of frequency  $510 \text{ Hz}$ .

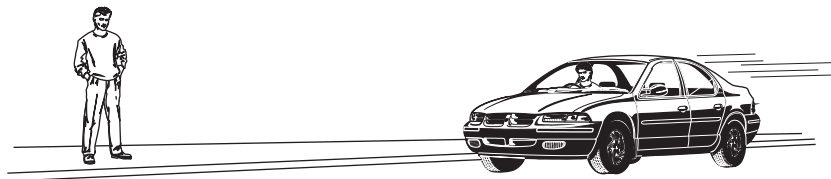

The person observes that the frequency of the sound heard changes as the car passes.

- (i) State the name given to this effect. 1

- (ii) Calculate the frequency of the sound heard by the person as the car approaches.

The speed of sound in air is  $340 \text{ m s}^{-1}$ . 3

*Space for working and answer*



5. (continued)

MARKS  
DO NOT  
WRITE IN  
THIS  
MARGIN

- (b) This same effect is used to determine the speed of red blood cells through blood vessels.

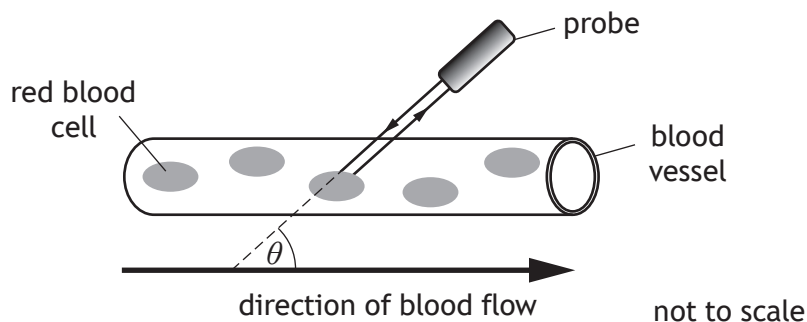

Ultrasound waves are transmitted by a probe. The frequency of the ultrasound waves changes as they reflect from the blood cells. The probe detects the reflected waves.

The velocity of the red blood cells can be determined using the following relationship

$$\Delta f = \frac{2f v_{rbc} \cos\theta}{v}$$

where  $\Delta f$  is the change in frequency

$f$  is the transmitted frequency

$v_{rbc}$  is the velocity of the red blood cells

$v$  is the velocity of the ultrasound

$\theta$  is the angle between the direction of the waves and the direction of the blood flow.

The frequency of the ultrasound transmitted by the probe is 3.70 MHz.

The velocity of the ultrasound is 1540 m s<sup>-1</sup>.

During one test, the angle between the direction of the waves and blood flow is 60.0°. The change in frequency of the ultrasound is 286 Hz.

Calculate the velocity of the red blood cells during this test.

2

*Space for working and answer*



6. Stars emit radiation with a range of wavelengths. The peak wavelength of the radiation depends on the surface temperature of the star.

(a) The graph shows how the energy emitted per second per unit area varies with the wavelength  $\lambda$  of the radiation for a star with a surface temperature of 5000 K.

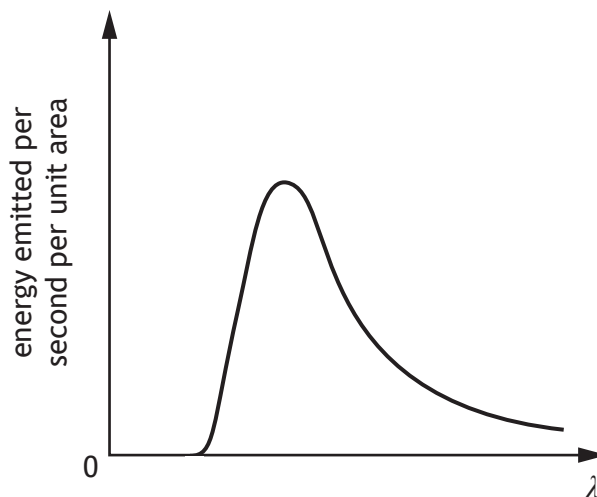

A second star has a surface temperature of 6000 K.

On the graph above, add a line to show how the energy emitted per second per unit area varies with the wavelength  $\lambda$  of the radiation for the second star.

2

(An additional graph, if required, can be found on page 44)



6. (continued)

- (b) The table gives the surface temperature  $T$ , in kelvin, of four different stars and the peak wavelength  $\lambda_{peak}$  of radiation emitted from each star.

$T$ (K)	$\lambda_{peak}$ (m)
7700	$3.76 \times 10^{-7}$
8500	$3.42 \times 10^{-7}$
9600	$3.01 \times 10^{-7}$
12 000	$2.42 \times 10^{-7}$

Use all the data in the table to show that the relationship between the surface temperature  $T$  of a star and the peak wavelength  $\lambda_{peak}$  radiated from the star is

3

$$T = \frac{2.9 \times 10^{-3}}{\lambda_{peak}}$$

Space for working and answer

[Turn over



\* X 8 5 7 7 6 0 1 1 7 \*

7. Scientists have recently discovered a type of particle called a pentaquark. Pentaquarks are very short lived and contain five quarks.

A lambda b ( $\Lambda_b$ ) pentaquark contains the following quarks: 2 up, 1 down, 1 charm, and 1 anticharm quark.

(a) Quarks and leptons are fundamental particles.

(i) Explain what is meant by the term *fundamental particle*.

1

(ii) State the name given to the group of matter particles that contains quarks and leptons.

1

(b) The table contains information about the charge on the quarks that make up the  $\Lambda_b$  pentaquark.

Type of quark	Charge
up	$+\frac{2}{3}e$
down	$-\frac{1}{3}e$
charm	$+\frac{2}{3}e$
anticharm	$-\frac{2}{3}e$

Determine the total charge on the  $\Lambda_b$  pentaquark.

2

Space for working and answer



\* X 8 5 7 7 6 0 1 1 8 \*

7. (continued)

- (c) One theory to explain the structure of the  $\Lambda_b$  pentaquark suggests that three of the quarks group together and one quark and the antiquark group together within the pentaquark.

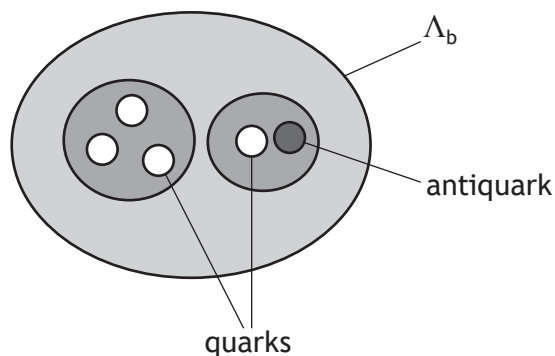

- (i) State the type of particle that is made of a quark-antiquark pair. 1

- (ii) The mean lifetime of another quark-antiquark pair is  $8.0 \times 10^{-21}$  s in its own frame of reference.

During an experiment the quark-antiquark pair is travelling with a velocity of  $0.91c$  relative to a stationary observer.

Calculate the mean lifetime of this quark-antiquark pair relative to the stationary observer. 3

*Space for working and answer*



7. (continued)

(d) The  $\Lambda_b$  pentaquark has a mass-energy equivalence of 4450 MeV.

One eV is equal to  $1.60 \times 10^{-19}$  J.

(i) Determine the energy, in joules, of the  $\Lambda_b$  pentaquark.

1

*Space for working and answer*

(ii) Calculate the mass of the  $\Lambda_b$  pentaquark.

3

*Space for working and answer*



\* X 8 5 7 7 6 0 1 2 0 \*

[Turn over for next question

DO NOT WRITE ON THIS PAGE



\* X 8 5 7 7 6 0 1 2 1 \*

8. The Sun emits energy at an average rate of  $4.1 \times 10^{26} \text{ J s}^{-1}$ . This energy is produced by nuclear reactions taking place inside the Sun.

The following statement shows one reaction that takes place inside the Sun.

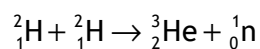

- (a) State the name given to this type of nuclear reaction.

1

- (b) The mass of the particles involved in this reaction are shown in the table.

Particle	Mass (kg)
${}^2_1\text{H}$	$3.3436 \times 10^{-27}$
${}^3_2\text{He}$	$5.0082 \times 10^{-27}$
${}^1_0\text{n}$	$1.6749 \times 10^{-27}$

Determine the energy released in this reaction.

4

*Space for working and answer*



MARKS

DO NOT  
WRITE IN  
THIS  
MARGIN

8. (continued)

- (c) Determine the number of these reactions that would be required per second to produce the Sun's average energy output.

2

*Space for working and answer*

[Turn over



\* X 8 5 7 7 6 0 1 2 3 \*

9. A laser emits light when electrons are stimulated to fall from a high energy level to a lower energy level.

The diagram shows some of the energy levels involved.

In one particular laser, a photon is produced by the electron transition from  $E_5$  to  $E_3$  as shown.

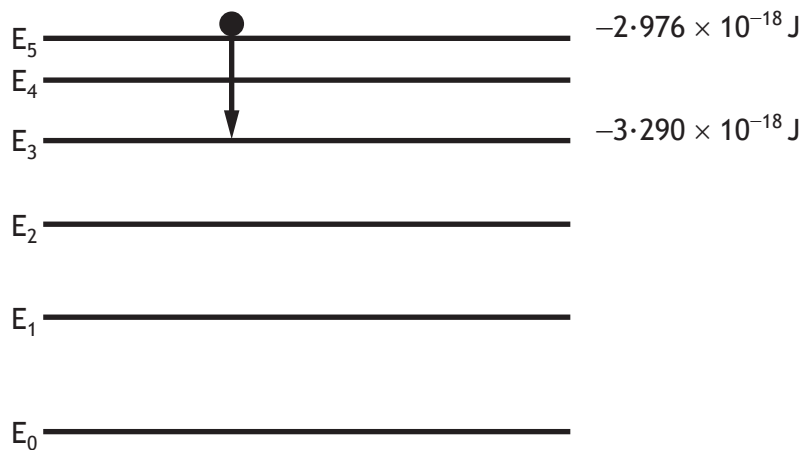

- (a) (i) Determine the wavelength of the photon emitted.  
*Space for working and answer*

4



9. (a) (continued)

- (ii) The laser beam is shone onto a screen. The beam produces a spot of diameter  $8.00 \times 10^{-4}$  m.

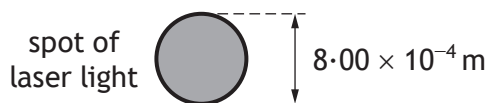

The irradiance of the spot of light on the screen is  $9950 \text{ W m}^{-2}$ .

Determine the power of the laser beam.

4

*Space for working and answer*

- (b) A student investigates how irradiance  $I$  varies with distance  $d$  from a point source of light, using the apparatus shown.

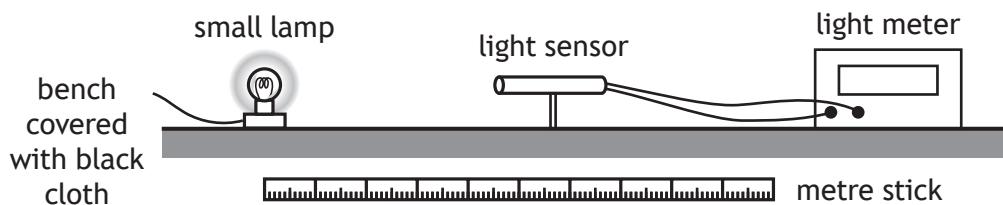

Describe how this apparatus could be used to verify the inverse square law for a point source of light.

3



10. A student carries out an experiment to investigate the effect of a grating on beams of light from three different lasers.

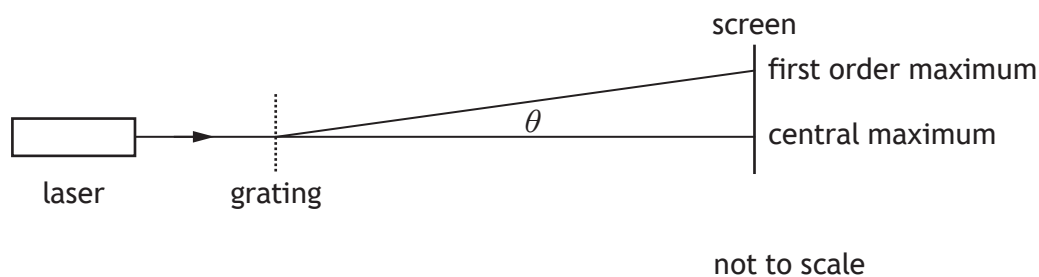

The three different lasers produce red, green and blue light respectively.  
 Each laser beam is directed in turn towards the grating.  
 The grating has a slit separation of  $3.3 \times 10^{-6}$  m.

- (a) State which of these three colours of laser light would produce the smallest angle  $\theta$  between the central maximum and the first order maximum.

Justify your answer.

3



10. (continued)

(b) The angle  $\theta$  between the central maximum and the first order maximum for light from one of the lasers is  $8.9^\circ$ .

(i) Calculate the wavelength of this light.

3

*Space for working and answer*

(ii) Determine the colour of the light from this laser.

1

(iii) Another student suggests that a more accurate value for the wavelength of this laser light can be found if a grating with a slit separation of  $5.0 \times 10^{-6}$  m is used.

Explain why this suggestion is incorrect.

2

[Turn over



\* X 8 5 7 7 6 0 1 2 7 \*

11. Diamonds sparkle because light that enters the diamond is reflected back to an observer.

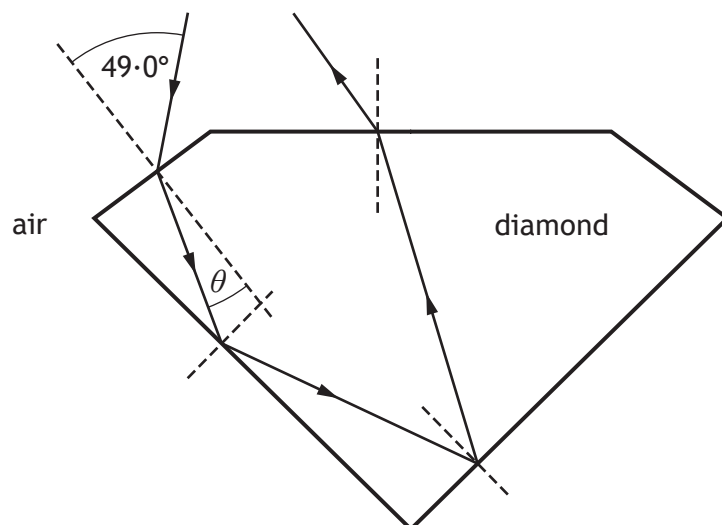

- (a) A ray of monochromatic light is incident on a diamond at an angle of  $49.0^\circ$ . The refractive index of diamond for this light is  $2.42$ . Calculate the angle of refraction  $\theta$ .  
*Space for working and answer*

3

- (b) Calculate the critical angle of the diamond for this light.  
*Space for working and answer*

3



## 11. (continued)

- (c) Moissanite is a transparent material with a greater refractive index than diamond. A sample of moissanite is made into the same shape as the diamond.

State whether the sample of moissanite sparkles more or less than the diamond.

You must justify your answer.

3

[Turn over



\* X 8 5 7 7 6 0 1 2 9 \*

12. (a) A student sets up the circuit shown.

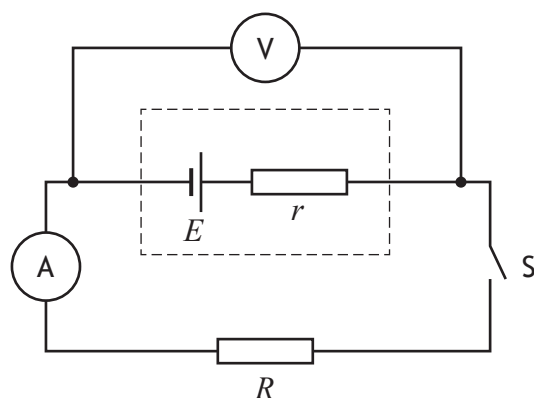

When switch  $S$  is open the reading on the voltmeter is  $1.5\text{ V}$ .

Switch  $S$  is now closed.

The reading on the voltmeter is now  $1.3\text{ V}$  and the reading on the ammeter is  $0.88\text{ A}$ .

(i) State the EMF  $E$  of the cell.

1

(ii) Calculate the internal resistance  $r$  of the cell.

3

*Space for working and answer*

(iii) Explain why the reading on the voltmeter decreases when the switch is closed.

2



\* X 8 5 7 7 6 0 1 3 0 \*

12. (continued)

- (b) A battery of EMF  $9.0\text{ V}$  and internal resistance  $1.2\ \Omega$  is connected in series with a lamp. The lamp has a resistance of  $2.4\ \Omega$ .

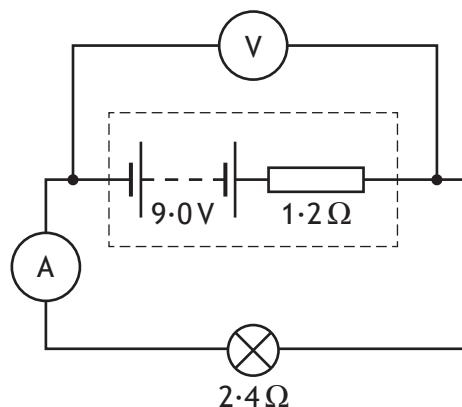

- (i) Determine the current in the lamp.

3

*Space for working and answer*

- (ii) Calculate the power dissipated in the lamp.

3

*Space for working and answer*



13. A student investigates the charging of a capacitor.  
The student sets up the circuit as shown using a  $47\ \mu\text{F}$  capacitor.

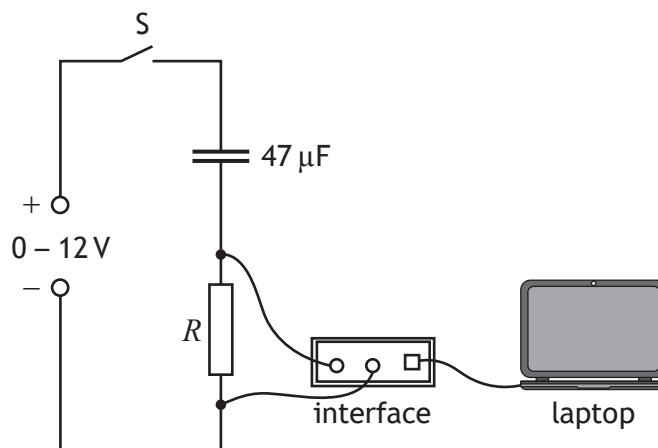

The capacitor is initially uncharged. The switch  $S$  is now closed. A laptop connected to an interface displays a graph of current against time as the capacitor charges.

- (a) The variable voltage supply is set at  $6.0\text{V}$ .  
Calculate the maximum charge stored by the capacitor.  
*Space for working and answer*

3



13. (continued)

- (b) The graph shows how the current  $I$  varies with time  $t$  as the capacitor charges.

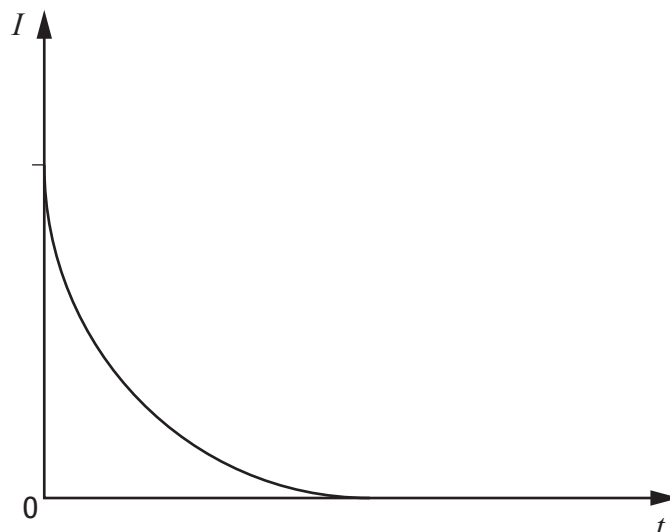

Switch S is opened, and the capacitor is discharged.

The resistor is now replaced with one that has a greater resistance.

Switch S is again closed and the capacitor charges.

Add a line to the graph above to show how the current now varies with time as the capacitor charges.

2

(An additional graph, if required, can be found on page 45.)

- (c) Suggest an alteration the student could make to this circuit to increase the maximum energy stored by the  $47\ \mu\text{F}$  capacitor.

1

[Turn over



\* X 8 5 7 7 6 0 1 3 3 \*

13. (continued)

(d) The use of analogies from everyday life can help improve the understanding of physics concepts.

Vehicles using a car park may be taken as an analogy for the charging of a capacitor.

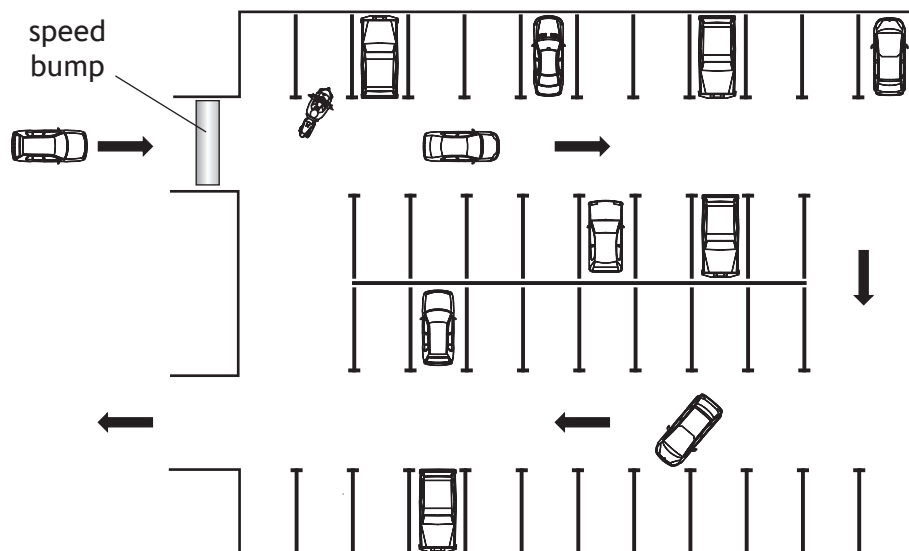

Use your knowledge of physics to comment on this analogy.

3



DO NOT  
WRITE IN  
THIS  
MARGIN

13. (d) (continued)

[Turn over



\* X 8 5 7 7 6 0 1 3 5 \*

14. Solids can be categorised as conductors, insulators or semiconductors depending on their ability to conduct electricity. Their electrical conductivity can be explained using band theory.

The diagrams show the valence and conduction bands of three solids X, Y and Z.

One represents a conductor, one represents an insulator and one represents a semiconductor.

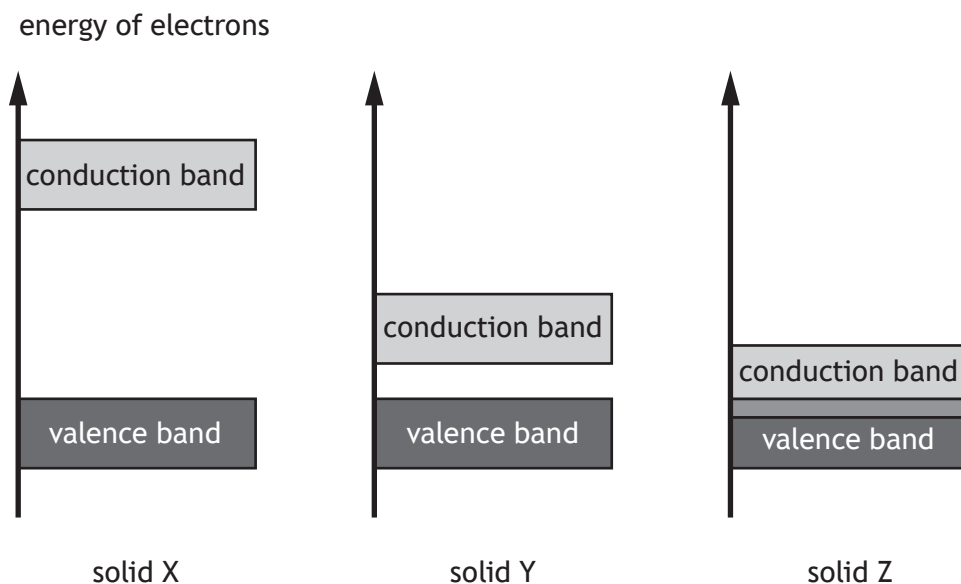

- (a) Complete the table to show which solid represents a conductor, an insulator and a semiconductor.

1

Solid	Category
X	
Y	
Z	



14. (continued)

(b) Using **band theory**, explain why conduction can take place in a semiconductor at room temperature. 2

(c) Silicon can be doped with arsenic to produce an n-type semiconductor. State the effect that doping has on the conductivity of silicon. 1

(d) Resistivity is a measure of a material's property to oppose the flow of charge. 2

The resistivity of silicon is  $2.3 \times 10^3 \Omega \text{ m}$ .

The resistivity of copper is  $1.7 \times 10^{-8} \Omega \text{ m}$ .

Compare the resistivity of silicon to the resistivity of copper in terms of orders of magnitude.

*Space for working and answer*



[BLANK PAGE]

DO NOT WRITE ON THIS PAGE



\* X 8 5 7 7 6 0 1 3 8 \*

15. A 1.00 m long wooden rod has a series of small holes drilled at 10 mm intervals along its length. The rod is hung on a horizontal pin passing through a hole 50 mm from one end.

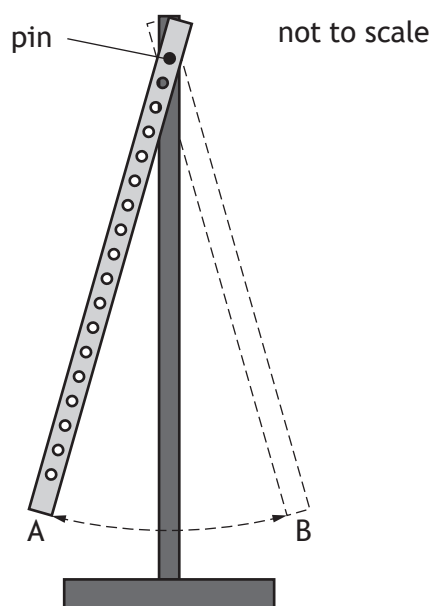

The rod is then raised through a small angle and released.

The period  $T$  is the time for the rod to travel from A to B and back to A.

- (a) Describe a method to obtain an accurate value for the period  $T$  using only a stopwatch.

2



15. (continued)

- (b) The rod is hung from different holes in turn, and the distance  $h$  from the pin to the midpoint of the rod is recorded.

$T$  is determined for each value of  $h$ . The results are shown in the table.

$h$ (m)	$T$ (s)
0.45	1.60
0.40	1.56
0.35	1.54
0.30	1.53
0.25	1.53
0.22	1.55
0.20	1.58

- (i) Using the square-ruled paper on *page 41*, draw a graph of  $T$  against  $h$ . 3
- (ii) Using your graph, state the **two** values of  $h$  that produce a period of 1.57 s. 1
- (iii) (A) Using your graph, estimate the minimum period  $T$ . 1
- (B) Suggest an improvement to the experimental procedure that would allow a more precise value for the minimum period  $T$  to be determined. 1



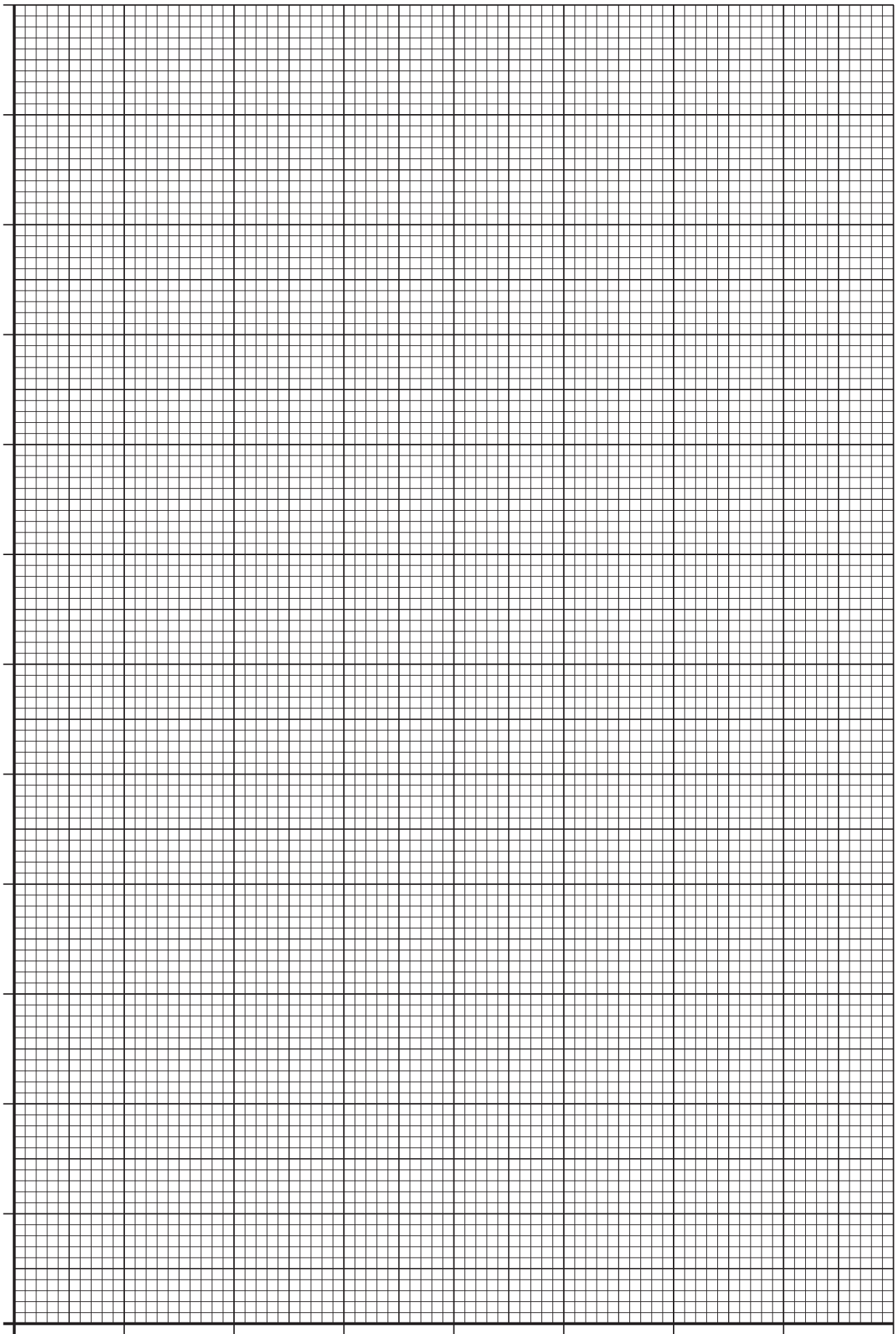

\* X 8 5 7 7 6 0 1 4 1 \*

15. (continued)

(c) The quantities  $T$  and  $h$  are related by the relationship

$$T^2h = \frac{4\pi^2h^2}{g} + C$$

where  $g$  is the gravitational field strength and  $C$  is a constant.

Use data from the table on page 40 to calculate a value for  $C$  when  $h$  is 0.30 m.

A unit is not required.

2

*Space for working and answer*

[END OF QUESTION PAPER]



\* X 8 5 7 7 6 0 1 4 2 \*

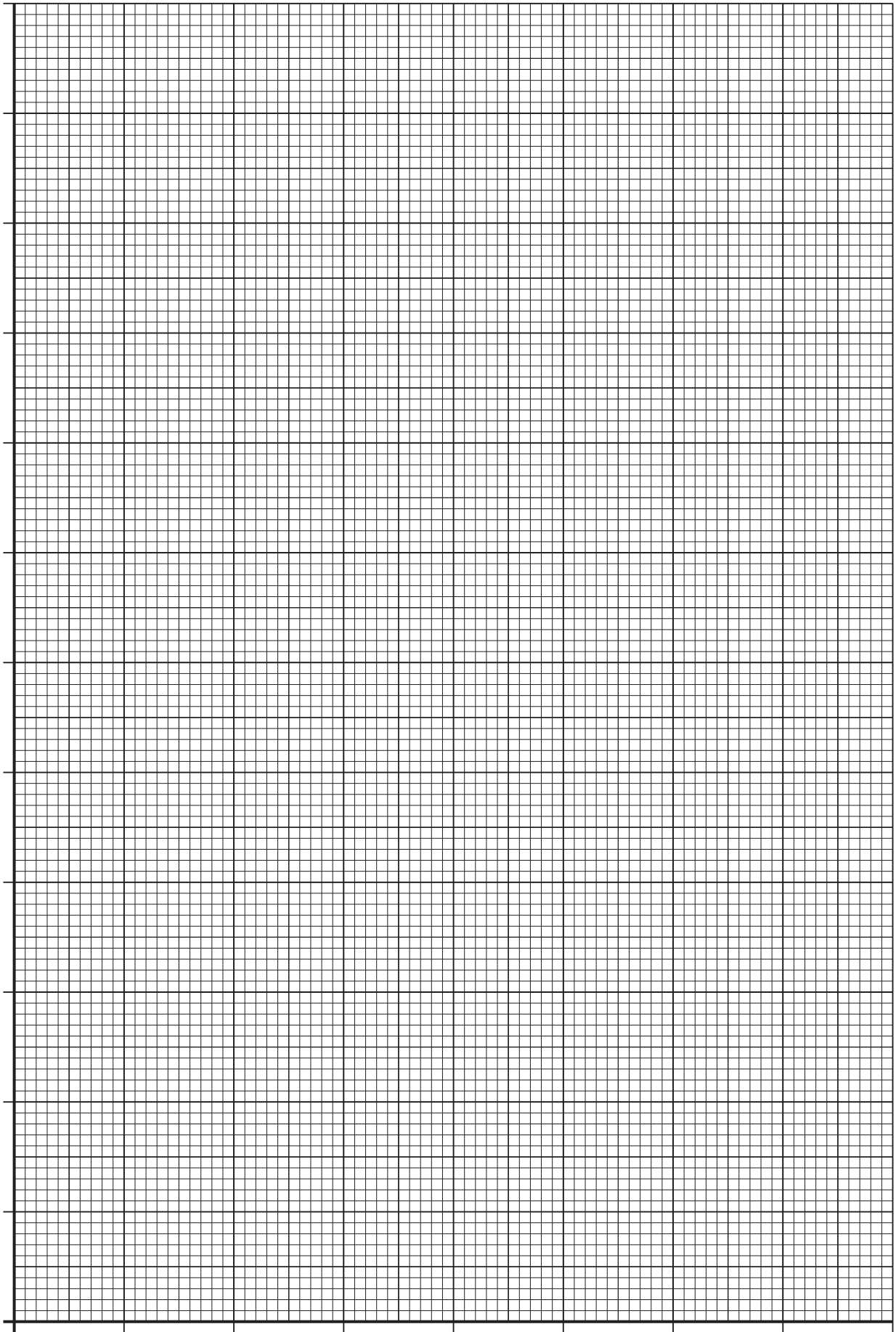

\* X 8 5 7 7 6 0 1 4 3 \*

## ADDITIONAL SPACE FOR ANSWERS AND ROUGH WORK

Additional graph for use with Question 1 (c)

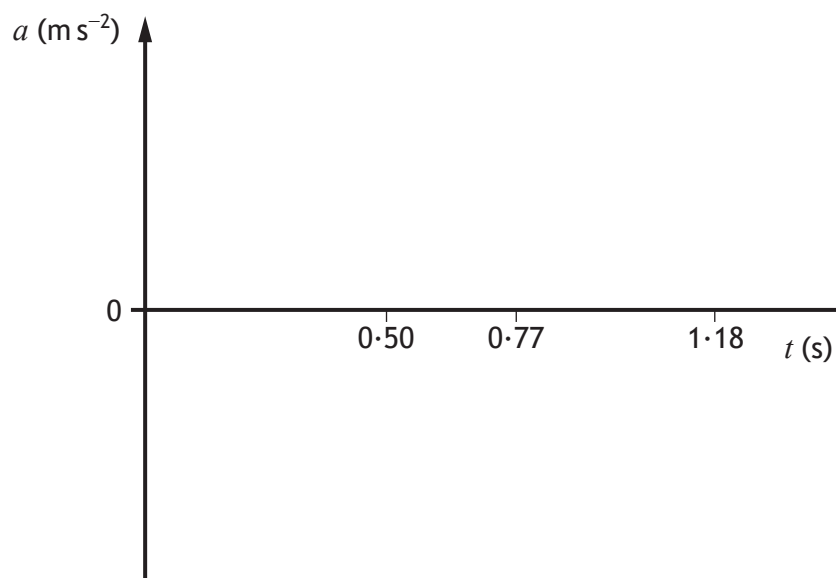

Additional graph for use with Question 6 (a)

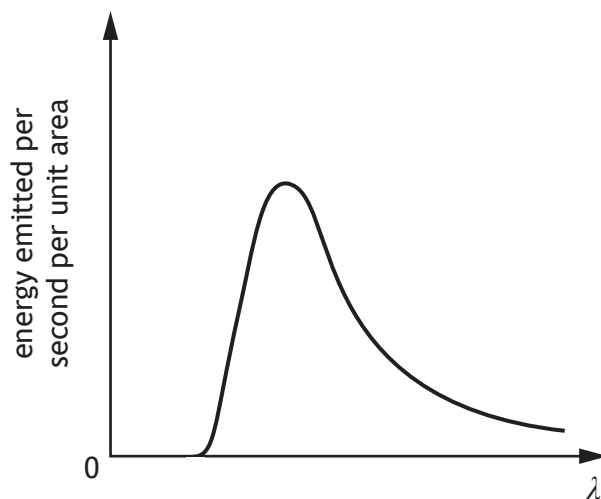

\* X 8 5 7 7 6 0 1 4 4 \*

MARKS

DO NOT  
WRITE IN  
THIS  
MARGIN

ADDITIONAL SPACE FOR ANSWERS AND ROUGH WORK

Additional graph for use with Question 13 (b)

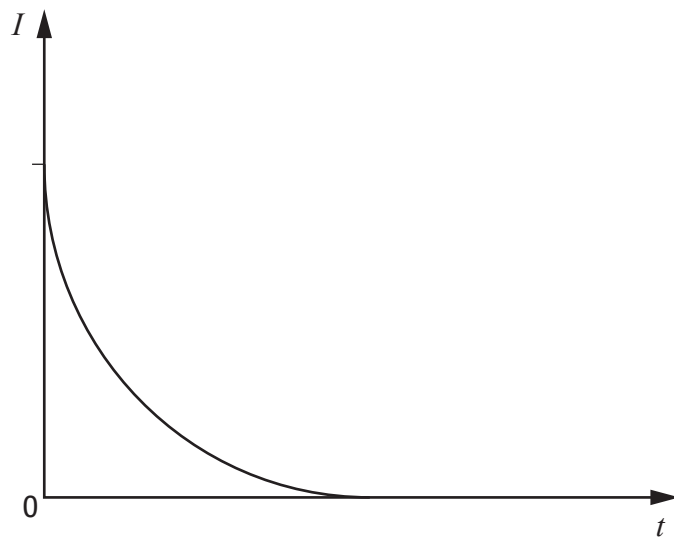

\* X 8 5 7 7 6 0 1 4 5 \*

MARKS

DO NOT  
WRITE IN  
THIS  
MARGIN

ADDITIONAL SPACE FOR ANSWERS AND ROUGH WORK



\* X 8 5 7 7 6 0 1 4 6 \*

MARKS

DO NOT  
WRITE IN  
THIS  
MARGIN

ADDITIONAL SPACE FOR ANSWERS AND ROUGH WORK



\* X 8 5 7 7 6 0 1 4 7 \*

[BLANK PAGE]

DO NOT WRITE ON THIS PAGE



\* X 8 5 7 7 6 0 1 4 8 \*