

FOR OFFICIAL USE



--	--	--	--	--	--

National  
Qualifications  
2022

Mark

--

**X857/76/01**

**Physics  
Paper 2**

FRIDAY, 13 MAY  
10:15 AM – 12:30 PM



Fill in these boxes and read what is printed below.

Full name of centre

--

Town

--

Forename(s)

--

Surname

--

Number of seat

--

Date of birth

Day

--	--

Month

--	--

Year

--	--

Scottish candidate number

--	--	--	--	--	--	--	--	--	--

**Total marks — 130**

Attempt ALL questions.

**You may use a calculator.**

Reference may be made to the Data Sheet on *page 02* of this booklet and to the relationship sheet X857/76/11.

Care should be taken to give an appropriate number of significant figures in the final answers to calculations.

Write your answers clearly in the spaces provided in this booklet. Additional space for answers and rough work is provided at the end of this booklet. If you use this space you must clearly identify the question number you are attempting. Any rough work must be written in this booklet. Score through your rough work when you have written your final copy.

Use **blue** or **black** ink.

Before leaving the examination room you must give this booklet to the Invigilator; if you do not, you may lose all the marks for this paper.



## DATA SHEET

### COMMON PHYSICAL QUANTITIES

Quantity	Symbol	Value	Quantity	Symbol	Value
Speed of light in vacuum	$c$	$3.00 \times 10^8 \text{ m s}^{-1}$	Planck's constant	$h$	$6.63 \times 10^{-34} \text{ J s}$
Magnitude of the charge on an electron	$e$	$1.60 \times 10^{-19} \text{ C}$	Mass of electron	$m_e$	$9.11 \times 10^{-31} \text{ kg}$
Universal Constant of Gravitation	$G$	$6.67 \times 10^{-11} \text{ m}^3 \text{ kg}^{-1} \text{ s}^{-2}$	Mass of neutron	$m_n$	$1.675 \times 10^{-27} \text{ kg}$
Gravitational acceleration on Earth	$g$	$9.8 \text{ m s}^{-2}$	Mass of proton	$m_p$	$1.673 \times 10^{-27} \text{ kg}$
Hubble's constant	$H_0$	$2.3 \times 10^{-18} \text{ s}^{-1}$			

### REFRACTIVE INDICES

The refractive indices refer to sodium light of wavelength 589 nm and to substances at a temperature of 273 K.

Substance	Refractive index	Substance	Refractive index
Diamond	2.42	Water	1.33
Crown glass	1.50	Air	1.00

### SPECTRAL LINES

Element	Wavelength (nm)	Colour	Element	Wavelength (nm)	Colour
Hydrogen	656	Red	Cadmium	644	Red
	486	Blue-green		509	Green
	434	Blue-violet		480	Blue
	410	Violet	Lasers		
	397	Ultraviolet	<b>Element</b>	<b>Wavelength (nm)</b>	<b>Colour</b>
	389	Ultraviolet	Carbon dioxide	9550 } 10590 }	Infrared
Sodium	589	Yellow	Helium-neon	633	Red

### PROPERTIES OF SELECTED MATERIALS

Substance	Density ( $\text{kg m}^{-3}$ )	Melting point (K)	Boiling point (K)
Aluminium	$2.70 \times 10^3$	933	2623
Copper	$8.96 \times 10^3$	1357	2853
Ice	$9.20 \times 10^2$	273	....
Sea Water	$1.02 \times 10^3$	264	377
Water	$1.00 \times 10^3$	273	373
Air	1.29	....	....
Hydrogen	$9.0 \times 10^{-2}$	14	20

The gas densities refer to a temperature of 273 K and a pressure of  $1.01 \times 10^5 \text{ Pa}$ .



\* X 8 5 7 7 6 0 1 0 2 \*

[Turn over for next question

DO NOT WRITE ON THIS PAGE



\* X 8 5 7 7 6 0 1 0 3 \*

Total marks — 130  
Attempt ALL questions

1. The crossbar challenge is a football contest in which competitors try and hit the crossbar of a goal by kicking a football from the penalty spot.
- The horizontal distance between the penalty spot and the crossbar is 11 m.
- One competitor kicks a football with an initial velocity of  $17.0 \text{ m s}^{-1}$  at an angle of  $24.0^\circ$  to the horizontal.

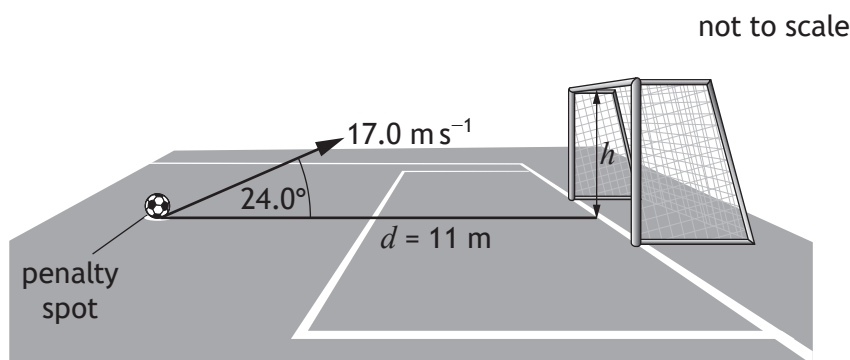

The football hits the crossbar.  
The effects of air resistance can be ignored.

- (a) (i) Calculate:
- (A) the horizontal component of the initial velocity of the football 1  
*Space for working and answer*
- (B) the vertical component of the initial velocity of the football. 1  
*Space for working and answer*



1. (a) (continued)

- (ii) Show that the time taken for the football to travel from the penalty spot to the crossbar is 0.71 s.

2

*Space for working and answer*

- (iii) The football is at the maximum height in its trajectory when it hits the crossbar.

3

Calculate the height  $h$  above the ground at which the football hits the crossbar.

*Space for working and answer*

- (b) The next time the competitor tries the challenge, they kick the football at the same angle with an initial speed less than  $17.0 \text{ m s}^{-1}$ .

State whether the football hits the crossbar, passes over the crossbar, or passes under the crossbar.

Justify your answer.

2



\* X 8 5 7 7 6 0 1 0 5 \*

2. A student carries out an experiment to investigate friction between a puck and the surface of a table.

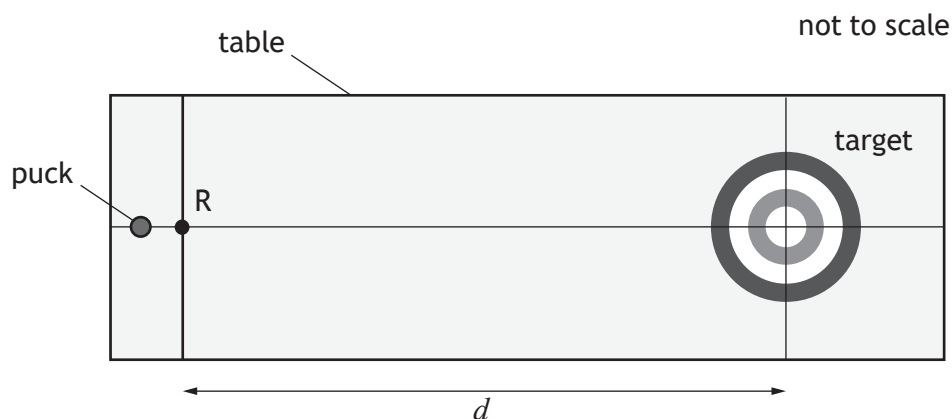

The student measures the mass  $m$  of the puck.

The student pushes the puck and releases it at point R. The student measures the initial speed  $u$  of the puck as it is released at R.

The puck travels distance  $d$  before coming to rest in the centre of the target.

The student records the following measurements:

mass of puck,  $m = 0.350$  kg

initial speed of puck,  $u = 0.78$  m s<sup>-1</sup>

distance travelled by puck,  $d = 2.160$  m.

- (a) (i) Calculate the average acceleration of the puck between point R and the centre of the target.

*Space for working and answer*

3



2. (a) (continued)

- (ii) Calculate the magnitude of the average force of friction between the puck and the table.

*Space for working and answer*

3

- (b) The student determines the absolute and percentage scale reading uncertainties for each measurement.

	Measurement	Absolute uncertainty	Percentage uncertainty
Mass of puck, $m$	0.350 kg	$\pm 0.001$ kg	0.3%
Initial speed of puck, $u$	$0.78 \text{ m s}^{-1}$	$\pm 0.01 \text{ m s}^{-1}$	1.3%
Distance travelled by puck, $d$	2.160 m	$\pm 0.001$ m	0.05%

The student makes the following statement:

‘The best way to reduce the uncertainty in the value calculated for the average force is to use a balance that measures to the nearest 0.0001 kg to measure the mass of the puck.’

Explain why the student’s statement is incorrect.

1

[Turn over



3. A student sets up an experiment to investigate the interaction between two trolleys on a smooth, horizontal track.

The mass of trolley X is 0.50 kg and the mass of trolley Y is 0.25 kg.

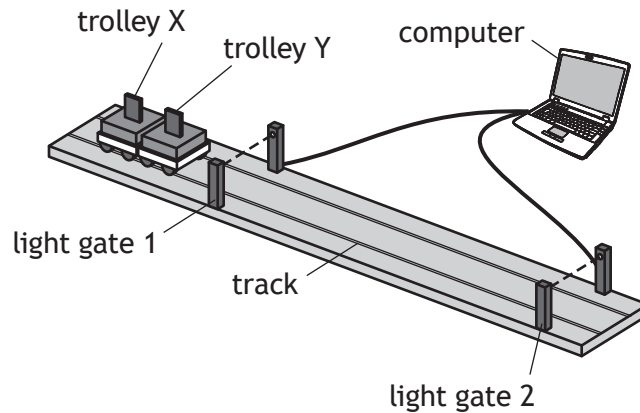

The trolleys X and Y are moving together to the right at  $0.40 \text{ m s}^{-1}$ .

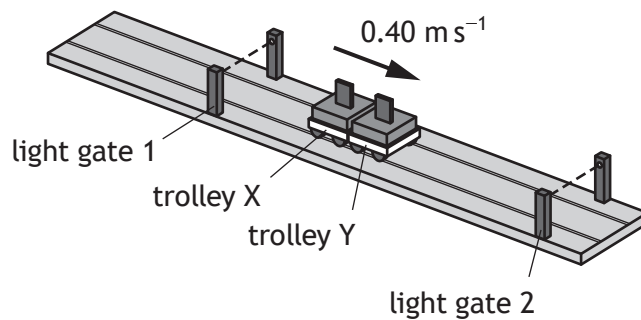

When the trolleys are between the light gates, a plunger in trolley X is activated.

The plunger extends and pushes trolley Y with an average force of 6.25 N for a short time, so that the trolleys separate.

Trolley Y now moves to the right at  $1.80 \text{ m s}^{-1}$ .

The effects of friction are negligible.

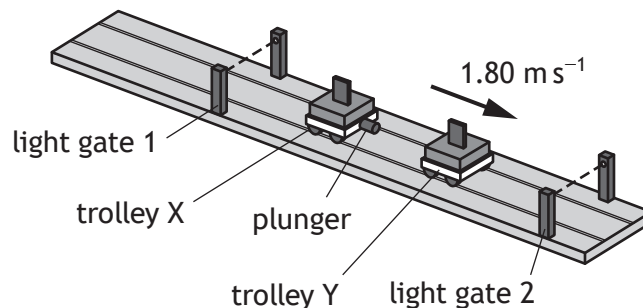

3. (continued)

- (a) (i) Calculate the magnitude of the change in momentum of trolley Y when the plunger is activated.

3

*Space for working and answer*

- (ii) Calculate the time during which the plunger exerts a force on trolley Y.

3

*Space for working and answer*

- (b) Calculate the velocity of trolley X immediately after the trolleys separate.

3

*Space for working and answer*



\* X 8 5 7 7 6 0 1 0 9 \*

3. (continued)

(c) Explain how the student would determine whether this interaction was elastic. 2

(d) The light gates used during the experiment each contain a lamp and a photodiode.

A photodiode is a p-n junction.

(i) A photodiode produces a potential difference when photons of light are incident on it.

State the name of this effect. 1

(ii) Light from the lamp is incident on the photodiode.

Using **band theory**, explain how a potential difference is produced when photons of light are incident on the photodiode. 3



[Turn over for next question

DO NOT WRITE ON THIS PAGE



\* X 8 5 7 7 6 0 1 1 1 \*

4. In 2012, a record was set for a stunt involving the highest skydive without deploying a parachute.

The person jumped from a helicopter at an altitude of 730 m above the ground. They ‘flew’ in a specially designed wing suit, at speeds of up to  $130 \text{ km h}^{-1}$ , for nearly 1.5 km before landing safely on empty cardboard boxes.

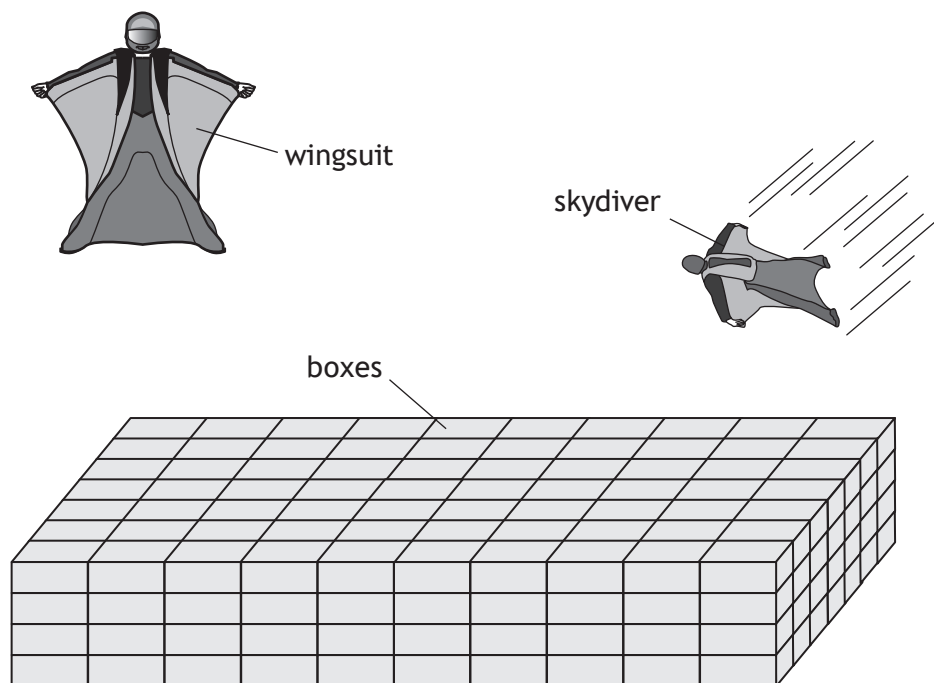

Using your knowledge of physics, comment on the challenges involved in carrying out the stunt successfully.

3



4. (continued)



\* X 8 5 7 7 6 0 1 1 3 \*

[BLANK PAGE]

DO NOT WRITE ON THIS PAGE



\* X 8 5 7 7 6 0 1 1 4 \*

5. A teacher uses a buzzer attached to a string to demonstrate the Doppler effect to a group of students.  
 The buzzer produces a sound of constant frequency.  
 The teacher swings the buzzer at a constant speed in a horizontal circle.

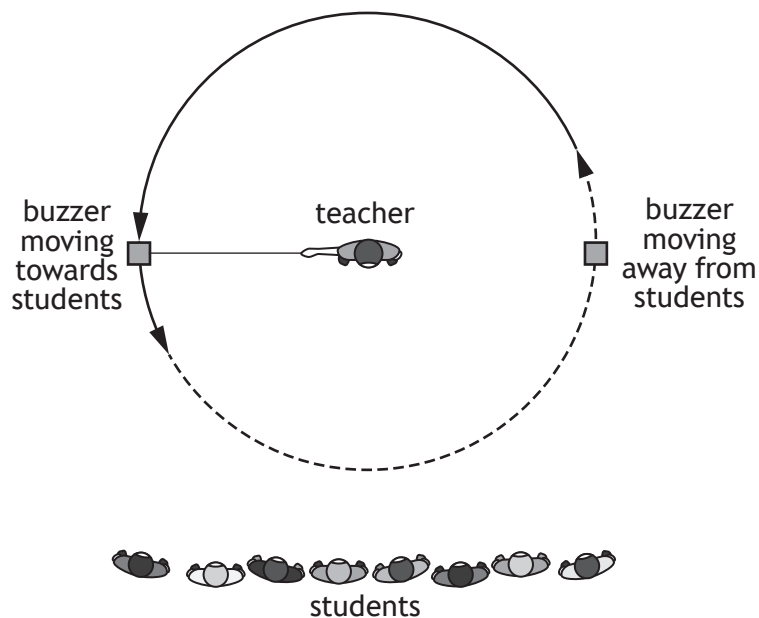

- (a) Explain, in terms of wavefronts, why the frequency of the sound heard by the students is lower as the buzzer moves away from them compared to when the buzzer is moving towards them.

You may wish to use a diagram.

2



5. (continued)

- (b) The teacher uses the Doppler effect model to explain observations of the light emitted by a binary star system.

A binary star system consists of two stars that orbit a common fixed point.

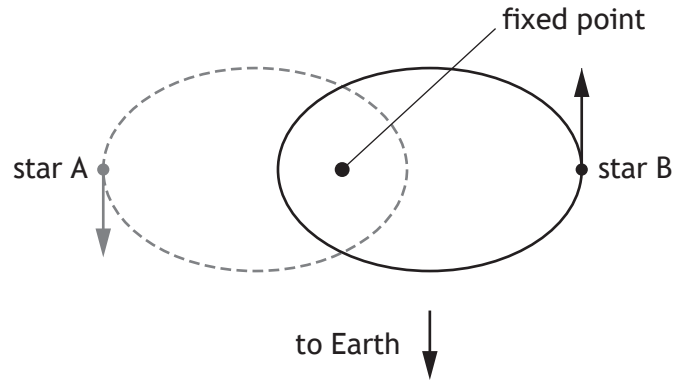

Line spectra are obtained from the stars in the binary system and compared with the line spectrum from the Sun.

Part of the line spectra for star B and the Sun are shown below.

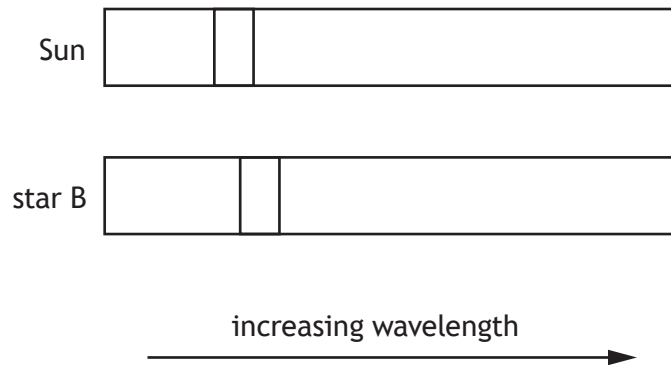

5. (b) (continued)

- (i) One of the lines in the spectrum from the Sun has a wavelength of 580 nm. The wavelength of the corresponding line in the spectrum from star B has a wavelength of 610 nm.

Calculate the redshift of star B.

*Space for working and answer*

3

- (ii) Determine the approximate distance from Earth to the binary star system.

*Space for working and answer*

5



\* X 8 5 7 7 6 0 1 1 7 \*

5. (continued)

- (c) (i) At one instant in their orbits around the fixed point, the stars in the binary system are  $3.44 \times 10^{12}$  m apart.

The mass of star A is  $2.19 \times 10^{30}$  kg and the mass of star B is  $1.80 \times 10^{30}$  kg.

Calculate the gravitational force between star A and star B at this instant. **3**

*Space for working and answer*

- (ii) At another point in their orbits the distance between the stars is half that in (c) (i).

State how many times greater the gravitational force between star A and star B is at this point, compared to that in (c) (i). **1**



[Turn over for next question

DO NOT WRITE ON THIS PAGE



\* X 8 5 7 7 6 0 1 1 9 \*

6. The Standard Model explains how the basic building blocks of matter interact, governed by four fundamental forces.
- (a) Name the type of particle that is composed of a quark–antiquark pair. 1
- (b) A particle known as a positive kaon ( $K^+$ ) is composed of an up quark and an anti-strange quark.
- (i) The negative kaon particle ( $K^-$ ) is the antiparticle of the  $K^+$  particle.  
State the names of the quarks that make up the  $K^-$  particle. 1
- (ii) The W-boson is the force-mediating particle associated with the decay of kaons.  
Name the fundamental force involved in the decay of kaons. 1



6. (continued)

(c) Another particle, known as a pion ( $\pi$ ), is a product of kaon decay.

A beam of pions, travelling in a straight line at a speed of  $0.95c$ , passes between two detectors.

The detectors are 30.0 m apart as measured by a stationary observer.

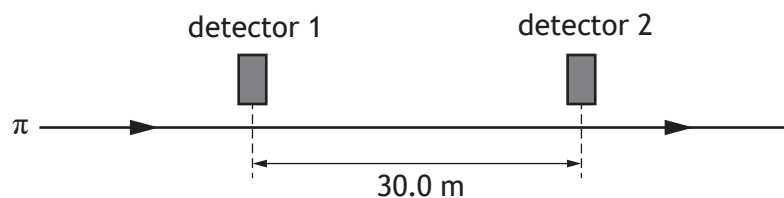

(i) Calculate the time taken for a pion to travel between the two detectors in the frame of reference of the stationary observer.

3

*Space for working and answer*

(ii) Calculate the distance between the two detectors in the frame of reference of the pions.

3

*Space for working and answer*



6. (continued)

- (d) Pions have a mean lifetime of 26 ns in their frame of reference.

Explain why a greater number of pions are detected at the second detector than would be expected if relativistic effects are not taken into account.

1

- (e) The use of analogies from everyday life can help improve the understanding of physics concepts.

A website states that the Standard Model is like a set of children's building blocks with all sorts of different shapes and sizes, and these building blocks make up all matter.

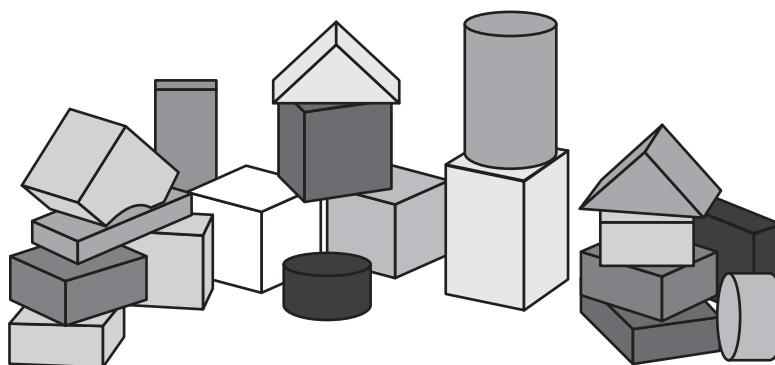

Using your knowledge of physics, comment on this analogy.

3



6. (e) (continued)



\* X 8 5 7 7 6 0 1 2 3 \*

7. Protons are accelerated by an electric field between metal plates A and B, in a vacuum.

Part of the apparatus used is shown.

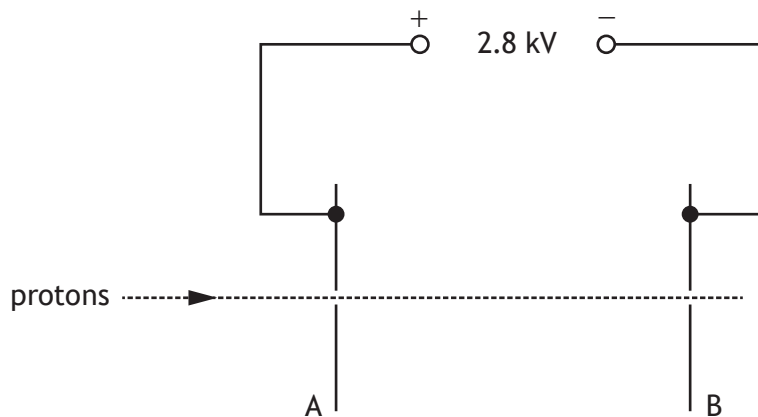

(a) Explain why the protons are accelerated by the electric field.

2

(b) (i) A proton is travelling at a speed of  $3.8 \times 10^5 \text{ m s}^{-1}$  at plate A.

Show that the kinetic energy of the proton at plate A is  $1.2 \times 10^{-16} \text{ J}$ .

2

*Space for working and answer*



7. (b) (continued)

- (ii) The potential difference between plates A and B is 2.8 kV.  
 Calculate the work done on the proton as it accelerates from plate A to plate B.

3

*Space for working and answer*

- (iii) Determine the speed of the proton at plate B.

4

*Space for working and answer*



\* X 8 5 7 7 6 0 1 2 5 \*

7. (continued)

(c) The distance between plates A and B is now doubled.

The potential difference between plates A and B is unchanged.

Another proton, with the same initial speed at plate A, is accelerated between the plates.

State what effect, if any, this has on the speed of the proton at plate B.

You must justify your answer.

2



\* X 8 5 7 7 6 0 1 2 6 \*

[Turn over for next question

DO NOT WRITE ON THIS PAGE



\* X 8 5 7 7 6 0 1 2 7 \*

8. A student investigates light from a sodium vapour lamp. Sodium vapour lamps emit yellow light.

The light from the lamp is passed through a collimator. The collimator is used to produce a parallel beam of light.

The apparatus is set up in a darkened laboratory.

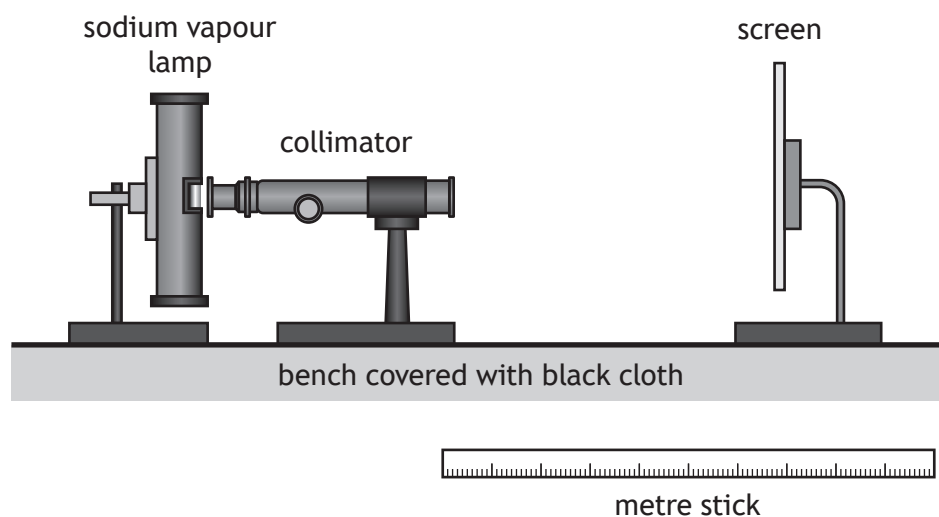

- (a) The parallel beam is shone onto a screen. The distance between the end of the collimator and the screen is 0.40 m.

The beam produces a uniformly lit spot of radius  $15 \times 10^{-3}$  m as shown.

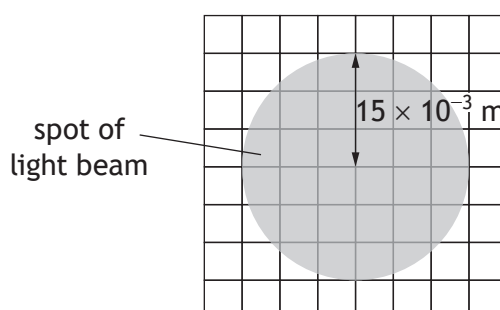

\* X 8 5 7 7 6 0 1 2 8 \*

8. (a) (continued)

(i) The irradiance of the spot of light on the screen is  $17 \text{ W m}^{-2}$ .

Determine the power of the beam of light.

4

*Space for working and answer*

(ii) The distance between the screen and the end of the collimator is now increased.

The spot produced on the screen has the same radius as before.

Explain why this experimental setup is not suitable for investigating the inverse square law.

1

[Turn over



\* X 8 5 7 7 6 0 1 2 9 \*

8. (continued)

- (b) The student now looks at the beam of light through a spectroscope and views a bright yellow spectral line with a wavelength of 589.0 nm.

This light is emitted when electrons make a transition from one energy level to another within sodium atoms.

- (i) State whether electrons are moving to a higher or a lower energy level when this light is emitted.

1

- (ii) Calculate the difference in energy between the two energy levels in the sodium atoms that produce this yellow light.

5

*Space for working and answer*



\* X 8 5 7 7 6 0 1 3 0 \*

## 8. (b) (continued)

(iii) The student observes a second yellow spectral line at a wavelength of 589.6 nm.

The student observes that the line at 589.0 nm is brighter than the line at 589.6 nm.

Explain the student's observation.

2

[Turn over



\* X 8 5 7 7 6 0 1 3 1 \*

9. The apparatus shown is used to investigate photoemission. Electromagnetic radiation is incident on metal X.

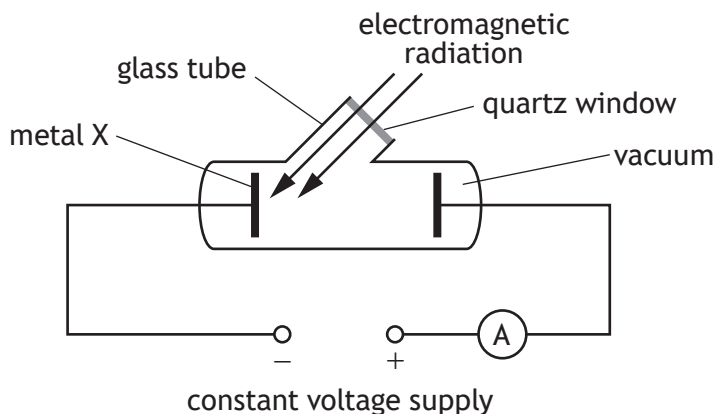

- (a) The frequency of the electromagnetic radiation is varied. The maximum kinetic energy of the photoelectrons emitted from metal X is determined for a range of frequencies.

The graph shows how the maximum kinetic energy  $E_k$  of the photoelectrons varies with frequency  $f$ .

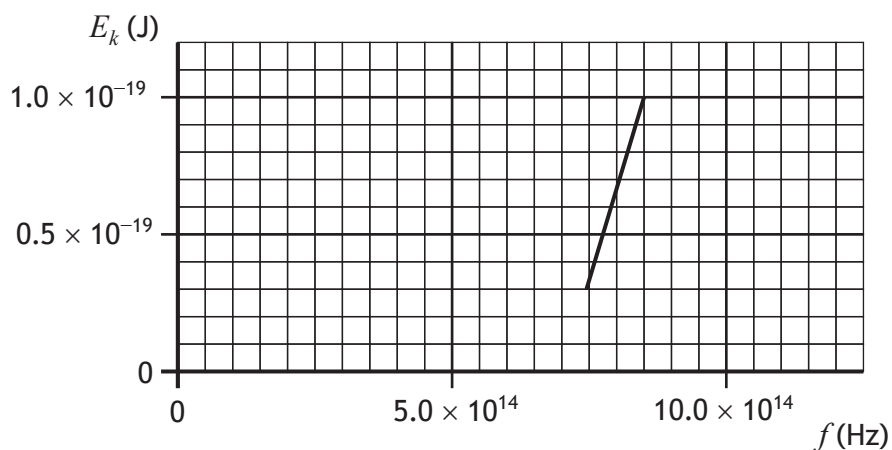

Using the graph, determine the threshold frequency  $f_0$  of metal X.

1



9. (continued)

(b) The work function of different metals is shown in the table.

Metal	Work function (J)
Potassium	$3.7 \times 10^{-19}$
Calcium	$4.6 \times 10^{-19}$
Zinc	$5.8 \times 10^{-19}$
Gold	$8.5 \times 10^{-19}$

Identify which of these metals is metal X.

Justify your answer by calculation.

*Space for working and answer*

4



10. A student is carrying out an experiment to investigate the interference of sound waves.

Two identical loudspeakers,  $L_1$  and  $L_2$ , are connected to a signal generator as shown.

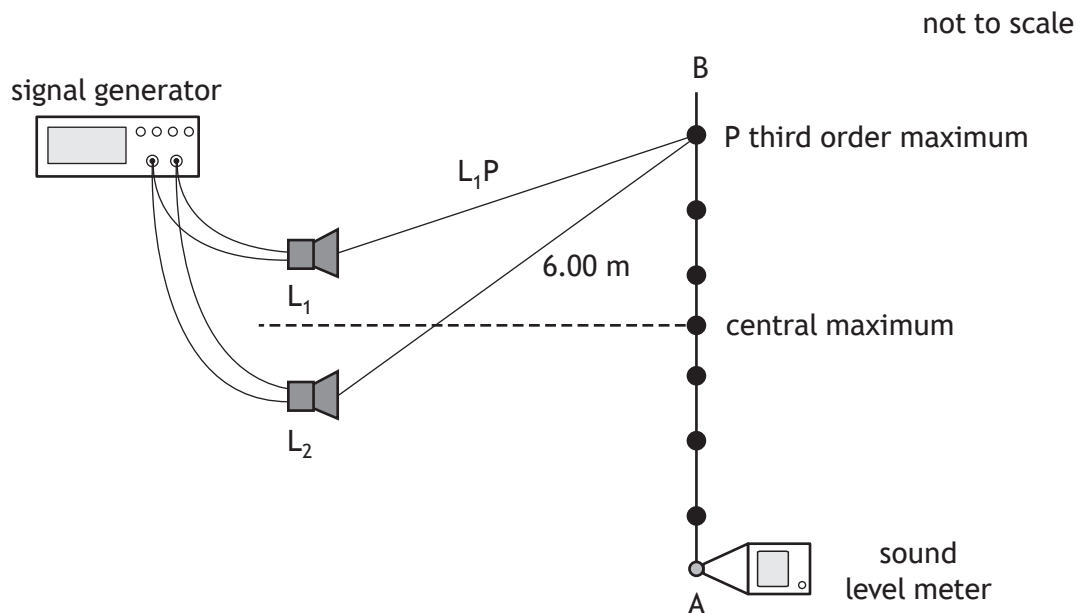

A sound level meter is moved from A to B, and a series of maxima are detected.

(a) The sound waves emitted from the loudspeakers are coherent.

State what is meant by the term *coherent*.

1

(b) Explain, in terms of waves, how a maximum is produced.

1



10. (continued)

- (c) The wavelength of the soundwaves is 0.400 m.  
 The distance from  $L_2$  to the third order maximum at point P is 6.00 m.  
 Determine the distance from  $L_1$  to P.

4

*Space for working and answer*

- (d) A second student in the room is wearing a pair of active noise cancelling (ANC) headphones.



The student switches on the ANC function. The sound level from the loudspeakers, heard by this student, decreases significantly.

Name the type of interference that the headphones use to reduce the sound level.

1



11. A triangular prism of borosilicate glass is placed inside a tank that has clear plastic walls.
- (a) A ray of monochromatic light passes through the glass prism and exits the plastic tank at point R, as shown.

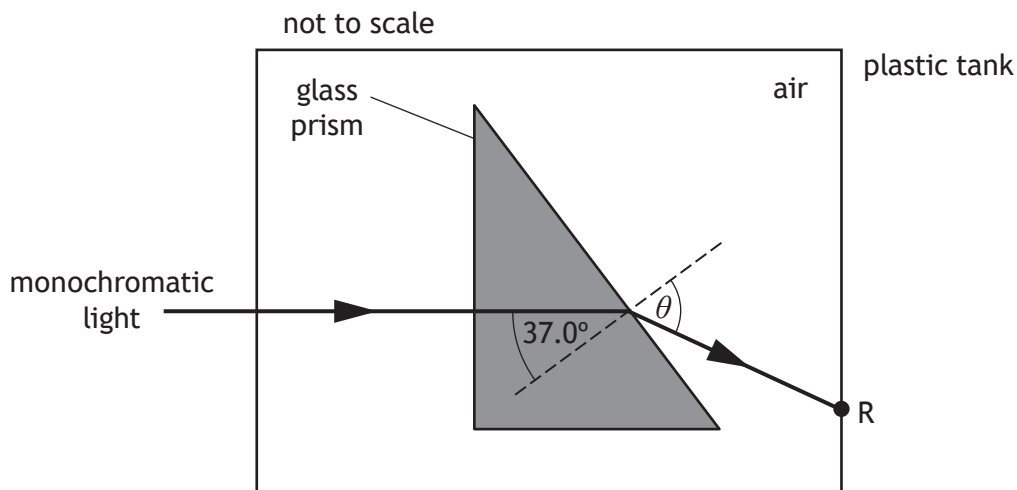

The refractive index of the glass for this light is 1.47.

Calculate angle  $\theta$ .

*Space for working and answer*

3

- (b) Calculate the critical angle of the glass for this light.

*Space for working and answer*

3



11. (continued)

- (c) The plastic tank is now filled with vegetable oil. The refractive index of the vegetable oil for this light is 1.47.

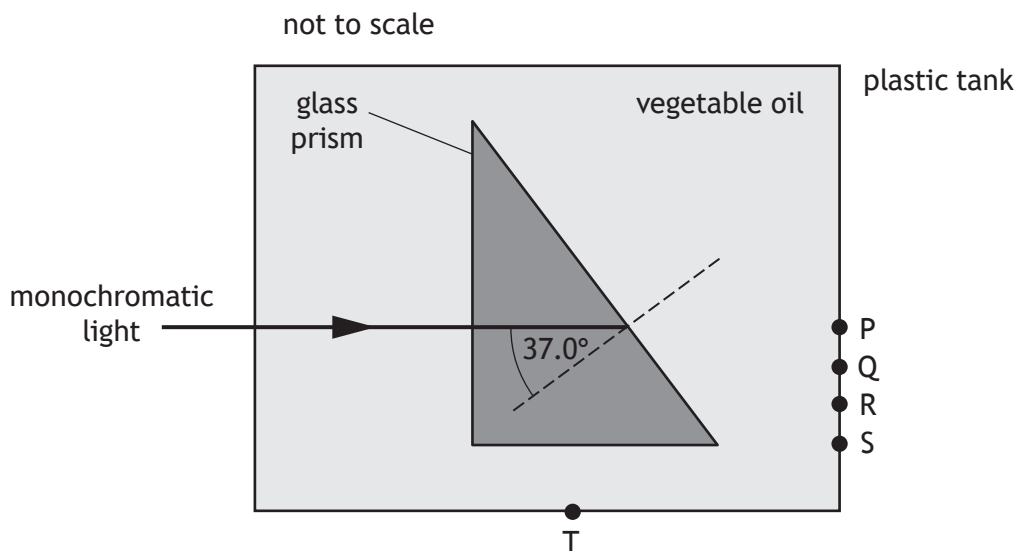

State at which point, P, Q, R, S, or T, the ray of light will now leave the plastic tank.

Justify your answer.

2

[Turn over



12. A student uses the following circuit to investigate the internal resistance  $r$  and EMF  $E$  of a battery.

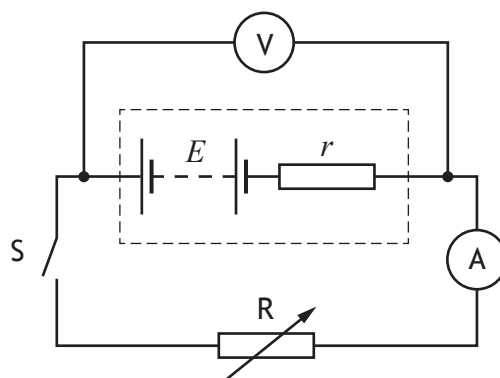

Switch S is closed.

The student uses readings of current  $I$  and terminal potential difference  $V$  from this circuit to produce the graph shown.

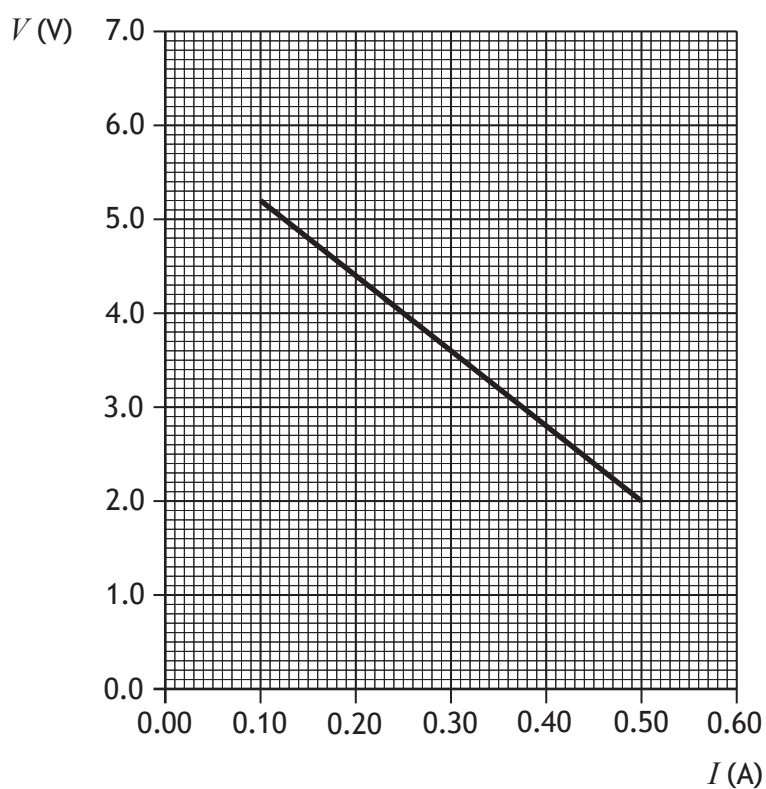

- (a) State what is meant by the term *electromotive force* (EMF).

1



12. (continued)

(b) Using information from the graph, determine:

(i) the EMF  $E$  of the battery

1

(ii) the internal resistance  $r$  of the battery.

3

*Space for working and answer*

(c) Using the circuit shown, describe how the student could measure the value of the EMF.

1

(d) Explain why the terminal potential difference of the battery decreases as the resistance of the variable resistor  $R$  is decreased.

2



\* X 8 5 7 7 6 0 1 3 9 \*

12. (continued)

- (e) The student now repeats the experiment with a different battery that has a smaller EMF and the same internal resistance.

On the graph below, add a line to show how the results of this experiment compare with the original experiment.

(An additional graph, if required, can be found on page 49.)

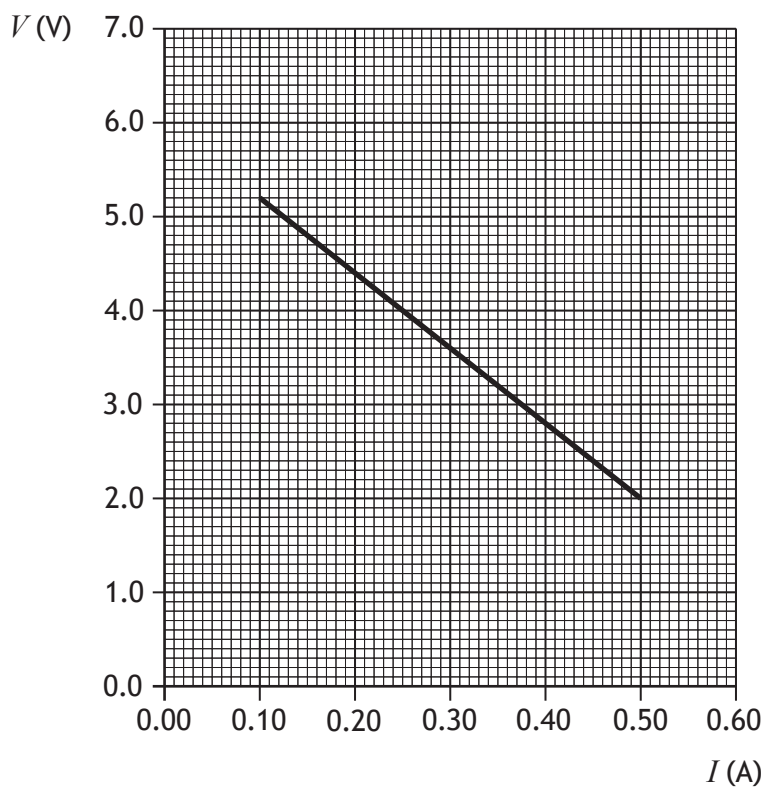

[Turn over for next question

DO NOT WRITE ON THIS PAGE



\* X 8 5 7 7 6 0 1 4 1 \*

13. A student carries out an experiment to investigate the charging of a capacitor, using the circuit shown.

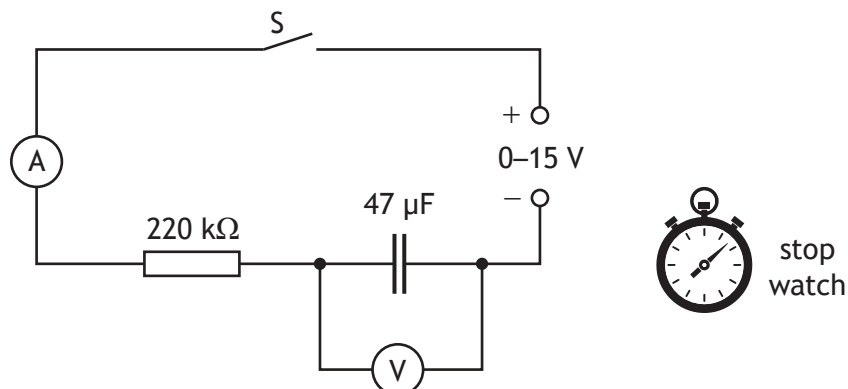

- (a) Describe how the results of this experiment are obtained **and** used to show how the voltage across the capacitor varies with time while the capacitor is charging.

2

- (b) The capacitor is initially uncharged.  
The variable voltage supply is set at 12 V.  
Switch S is closed.  
The capacitor becomes fully charged.

- (i) Calculate the maximum energy stored by the capacitor.

3

*Space for working and answer*



\* X 8 5 7 7 6 0 1 4 2 \*

13. (b) (continued)

(ii) Suggest an alteration the student could make to this circuit to increase the maximum energy stored by the  $47 \mu\text{F}$  capacitor.

1

[Turn over



\* X 8 5 7 7 6 0 1 4 3 \*

14. A student carries out an investigation to determine the gravitational field strength on Earth, using a simple pendulum.

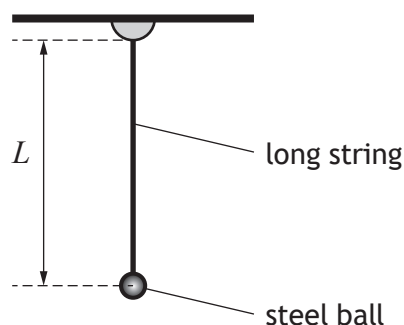

A long string has a steel ball attached to the end of it. The length  $L$  of the pendulum can be adjusted.

The ball is raised through a small angle and then released.

The student records the time for ten complete swings and uses this to determine a value for the period  $T$  of the pendulum. The student then determines the value of  $T^2$ .

The student repeats the experiment for different lengths.

The results are shown in the table.

$L$ (m)	$T^2$ (s <sup>2</sup> )
0.20	0.85
0.40	1.60
0.60	2.50
0.80	3.40
1.10	4.55

The gravitational field strength  $g$  can be determined using

$$\frac{T^2}{L} = \frac{4\pi^2}{g}$$

- (a) Using the square-ruled paper on *page 46*, draw a graph of  $T^2$  against  $L$ .  
(The table of results is also shown on *page 47*, opposite the square-ruled paper.)

3



14. (continued)

(b) Calculate the gradient of your graph.

*Space for working and answer*

2

(c) Using the gradient of your graph, determine the gravitational field strength  $g$ .

2

[END OF QUESTION PAPER]



\* X 8 5 7 7 6 0 1 4 5 \*

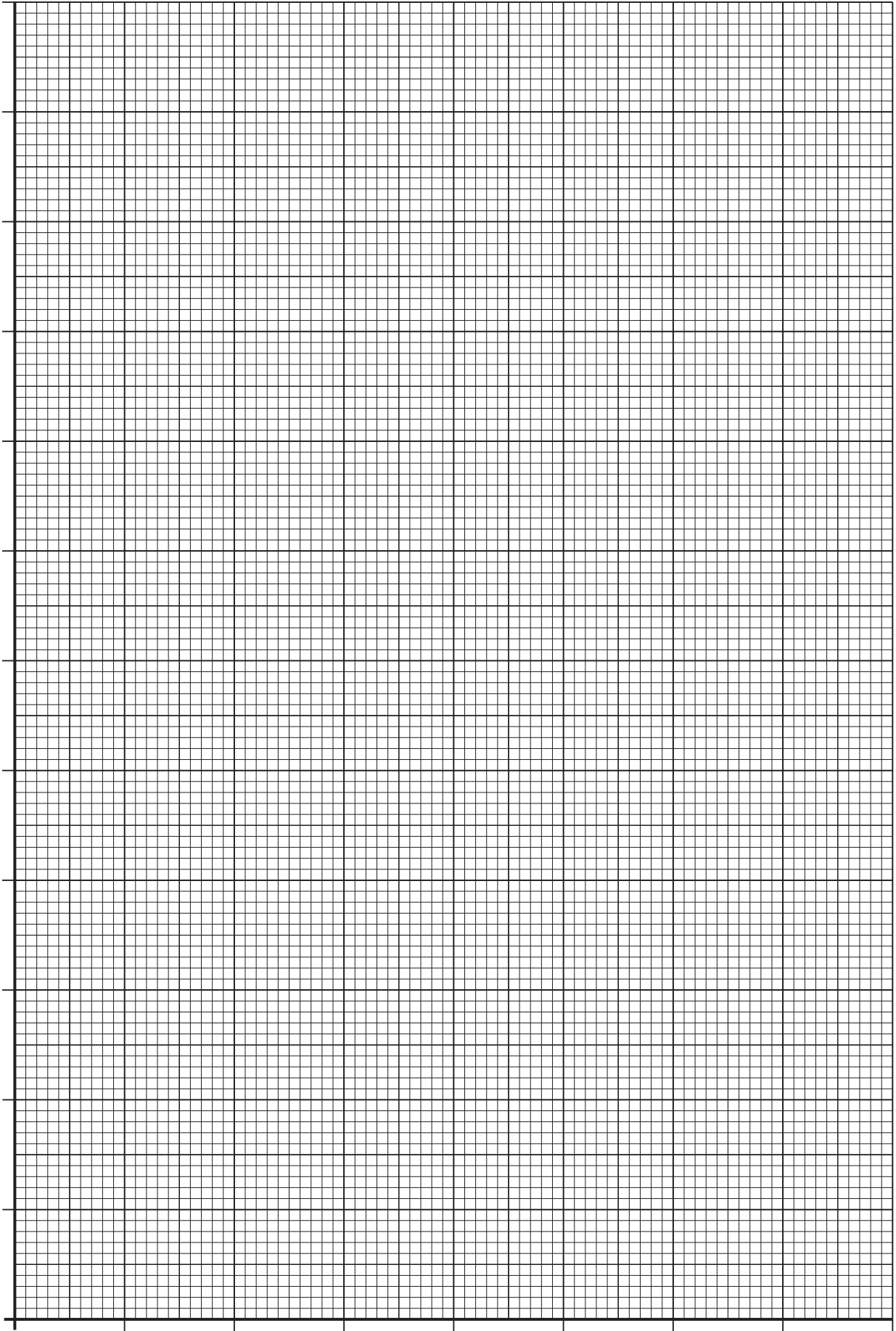

\* X 8 5 7 7 6 0 1 4 6 \*

Table of results for use with question 14 (a)

$L$ (m)	$T^2$ (s <sup>2</sup> )
0.20	0.85
0.40	1.60
0.60	2.50
0.80	3.40
1.10	4.55



\* X 8 5 7 7 6 0 1 4 7 \*

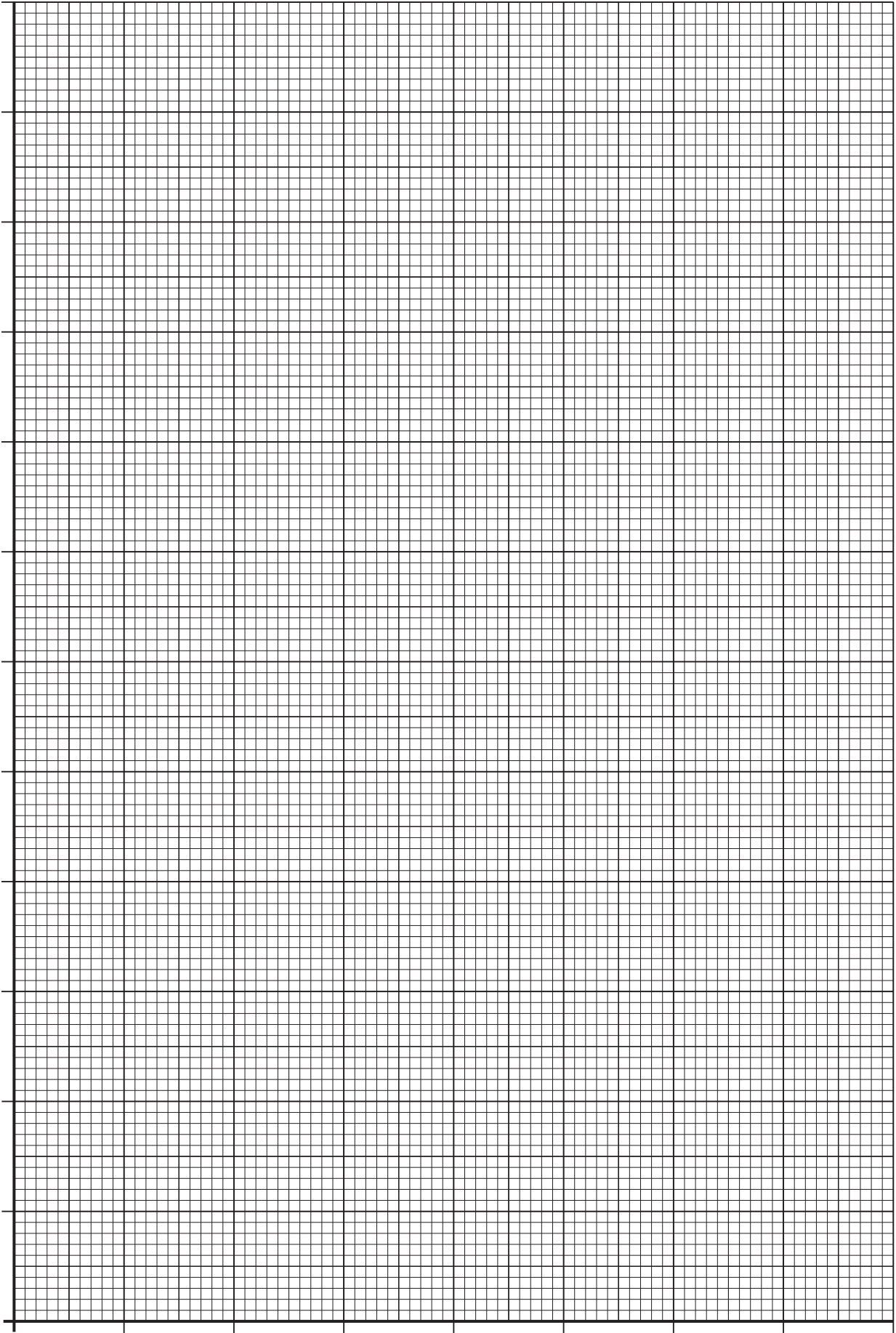

\* X 8 5 7 7 6 0 1 4 8 \*

ADDITIONAL SPACE FOR ANSWERS AND ROUGH WORK

Additional diagram for use with question 12 (e)

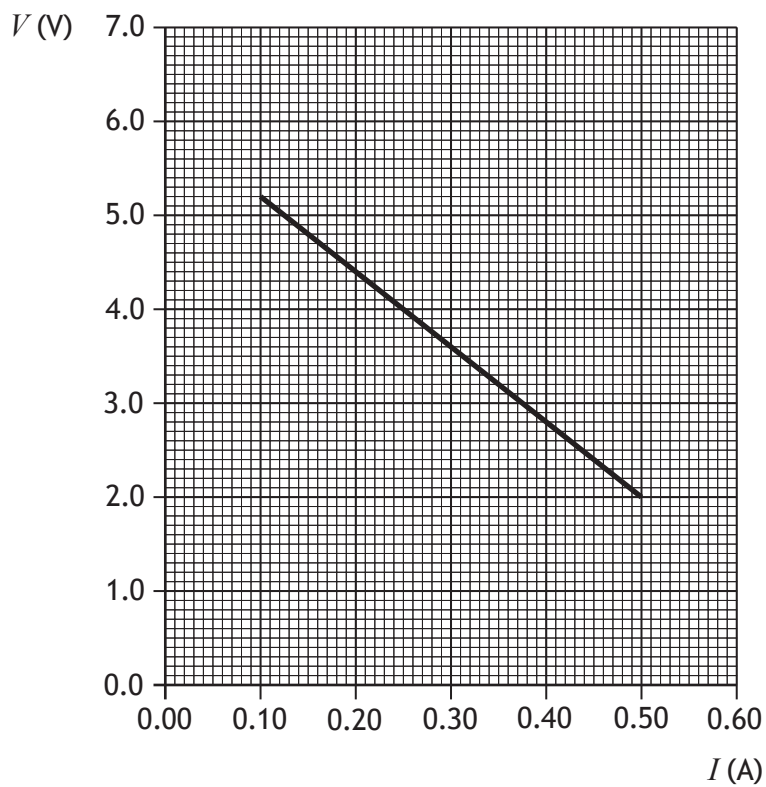

MARKS DO NOT  
WRITE IN  
THIS  
MARGIN

ADDITIONAL SPACE FOR ANSWERS AND ROUGH WORK



\* X 8 5 7 7 6 0 1 5 0 \*

MARKS DO NOT  
WRITE IN  
THIS  
MARGIN

ADDITIONAL SPACE FOR ANSWERS AND ROUGH WORK



\* X 8 5 7 7 6 0 1 5 1 \*

[BLANK PAGE]

DO NOT WRITE ON THIS PAGE

*Acknowledgement of copyright*

Question 10(d) Editorial image: Mohd Syis Zulkipli/shutterstock.com



\* X 8 5 7 7 6 0 1 5 2 \*