

FOR OFFICIAL USE



--	--	--	--	--	--

National
Qualifications
2025

Mark

--

X857/76/01

**Physics
Paper 2**

THURSDAY, 15 MAY
10:15 AM – 12:30 PM



Fill in these boxes and read what is printed below.

Full name of centre

--

Town

--

Forename(s)

--

Surname

--

Number of seat

--

Date of birth

Day

--	--

Month

--	--

Year

--	--

Scottish candidate number

--	--	--	--	--	--	--	--	--	--

Total marks — 130

Attempt ALL questions.

You may use a calculator.

Reference may be made to the data sheet on *page 02* of this booklet and to the relationships sheet X857/76/11.

Care should be taken to give an appropriate number of significant figures in the final answers to calculations.

Write your answers clearly in the spaces provided in this booklet. Additional space for answers and rough work is provided at the end of this booklet. If you use this space you must clearly identify the question number you are attempting. Any rough work must be written in this booklet. Score through your rough work when you have written your final copy.

Use **blue** or **black** ink.

Before leaving the examination room you must give this booklet to the Invigilator; if you do not, you may lose all the marks for this paper.



DATA SHEET

COMMON PHYSICAL QUANTITIES

Quantity	Symbol	Value	Quantity	Symbol	Value
Speed of light in vacuum	c	$3.00 \times 10^8 \text{ m s}^{-1}$	Planck's constant	h	$6.63 \times 10^{-34} \text{ J s}$
Magnitude of the charge on an electron	e	$1.60 \times 10^{-19} \text{ C}$	Mass of electron	m_e	$9.11 \times 10^{-31} \text{ kg}$
Universal Constant of Gravitation	G	$6.67 \times 10^{-11} \text{ m}^3 \text{ kg}^{-1} \text{ s}^{-2}$	Mass of neutron	m_n	$1.675 \times 10^{-27} \text{ kg}$
Gravitational acceleration on Earth	g	9.8 m s^{-2}	Mass of proton	m_p	$1.673 \times 10^{-27} \text{ kg}$
Hubble's constant	H_0	$2.3 \times 10^{-18} \text{ s}^{-1}$	Speed of sound in air	v_{air}	$3.40 \times 10^2 \text{ m s}^{-1}$

REFRACTIVE INDICES

The refractive indices refer to sodium light of wavelength 589 nm and to substances at a temperature of 273 K.

Substance	Refractive index	Substance	Refractive index
Diamond	2.42	Water	1.33
Crown glass	1.50	Air	1.00

SPECTRAL LINES

Element	Wavelength (nm)	Colour	Element	Wavelength (nm)	Colour
Hydrogen	656	Red	Cadmium	644	Red
	486	Blue-green		509	Green
	434	Blue-violet		480	Blue
	410	Violet	Lasers		
	397	Ultraviolet	Element	Wavelength (nm)	Colour
	389	Ultraviolet	Carbon dioxide	9550 } 10590 }	Infrared
Sodium	589	Yellow	Helium-neon	633	Red

PROPERTIES OF SELECTED MATERIALS

Substance	Density (kg m^{-3})	Melting point (K)	Boiling point (K)
Aluminium	2.70×10^3	933	2623
Copper	8.96×10^3	1357	2853
Ice	9.20×10^2	273
Sea Water	1.02×10^3	264	377
Water	1.00×10^3	273	373
Air	1.29
Hydrogen	9.0×10^{-2}	14	20

The gas densities refer to a temperature of 273 K and a pressure of $1.01 \times 10^5 \text{ Pa}$.



* X 8 5 7 7 6 0 1 0 2 *

[Turn over for next question

DO NOT WRITE ON THIS PAGE



* X 8 5 7 7 6 0 1 0 3 *

Total marks — 130
Attempt ALL questions

1. A television company uses a 'spider cam' to film a sporting event. A 'spider cam' is made up of a camera mount that carries a camera.

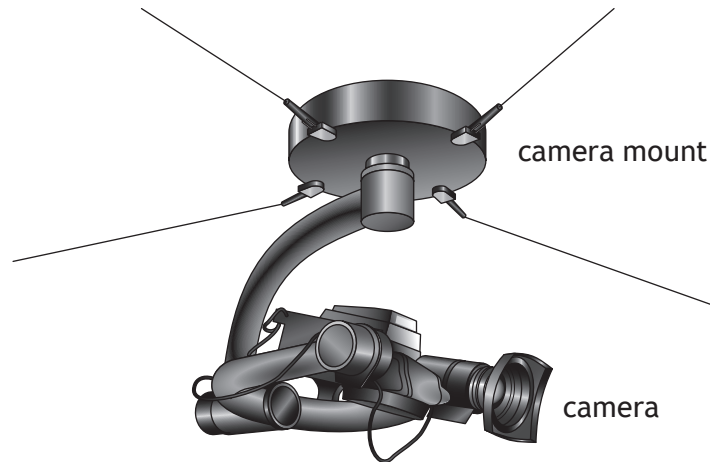

The camera mount is suspended from four cables. The length of the cables can be changed using a motor attached to each cable. This allows the height and position of the camera over the pitch to be changed.

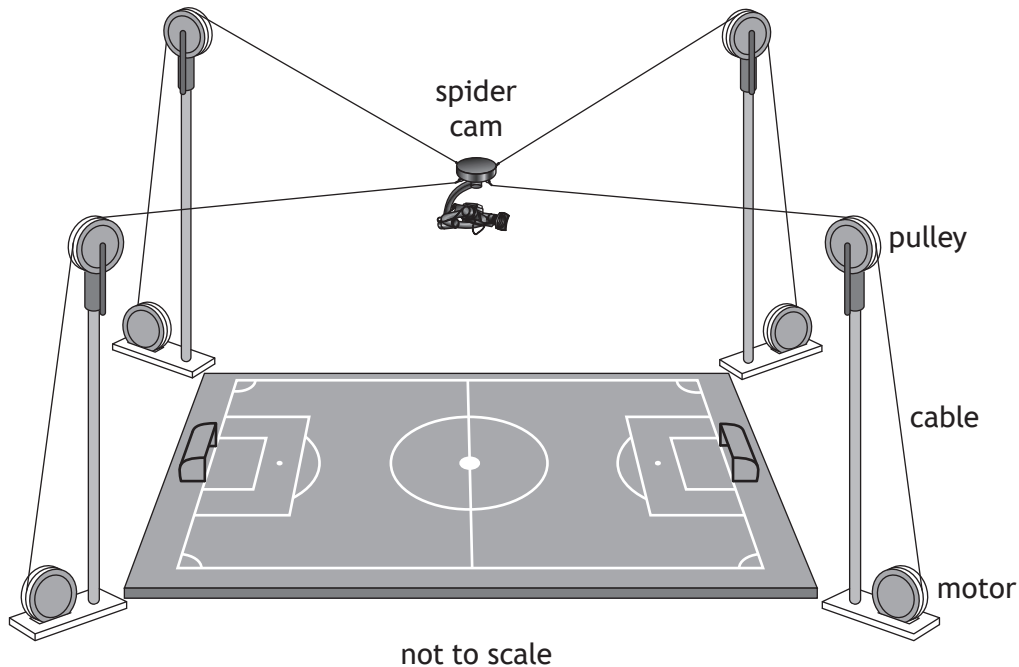

1. (continued)

The camera mount and camera have a maximum acceleration of 1.45 m s^{-2} and a maximum velocity of 8.86 m s^{-1} .

(a) (i) State what is meant by an *acceleration of 1.45 m s^{-2}* .

1

(ii) Calculate the distance travelled by the camera mount and camera as they accelerate at 1.45 m s^{-2} from rest to the maximum velocity.

3

Space for working and answer

[Turn over



* X 8 5 7 7 6 0 1 0 5 *

1. (continued)

- (b) During a test of the system, the camera mount and camera are held stationary at a constant maximum height above the centre of the pitch.

The total mass of the camera mount and camera is 31 kg.

At the maximum height, the angle that each cable makes to the horizontal is 12° .

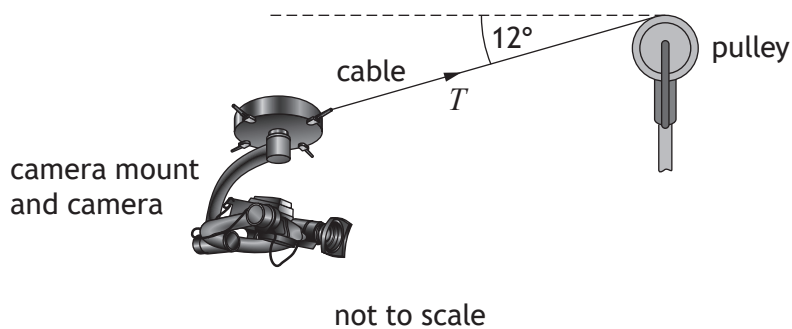

Determine the tension T in each of the four cables.

Space for working and answer

4



[Turn over for next question

DO NOT WRITE ON THIS PAGE



* X 8 5 7 7 6 0 1 0 7 *

2. A technician sets up the apparatus shown to demonstrate the law of conservation of linear momentum.

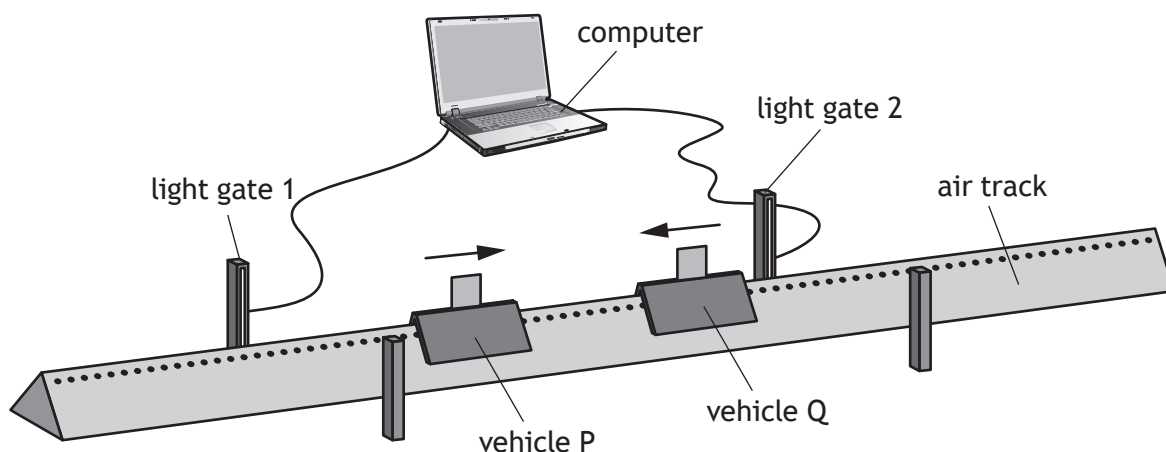

The mass of vehicle P is 0.18 kg and the mass of vehicle Q is 0.24 kg.

The effects of friction are negligible.

In one experiment, vehicle P is moving at 1.20 m s^{-1} to the right and vehicle Q is moving at 0.64 m s^{-1} to the left.

The vehicles collide and move off separately.

Vehicle P rebounds with a velocity of 0.76 m s^{-1} to the left.

- (a) State the law of conservation of linear momentum.

1

- (b) Calculate the velocity of vehicle Q immediately after the collision.

3

Space for working and answer



* X 8 5 7 7 6 0 1 0 8 *

2. (continued)

(c) Show by calculation whether the collision is elastic or inelastic.

4

Space for working and answer

[Turn over



* X 8 5 7 7 6 0 1 0 9 *

2. (continued)

- (d) The technician now sets up the linear air track to demonstrate the Doppler effect.

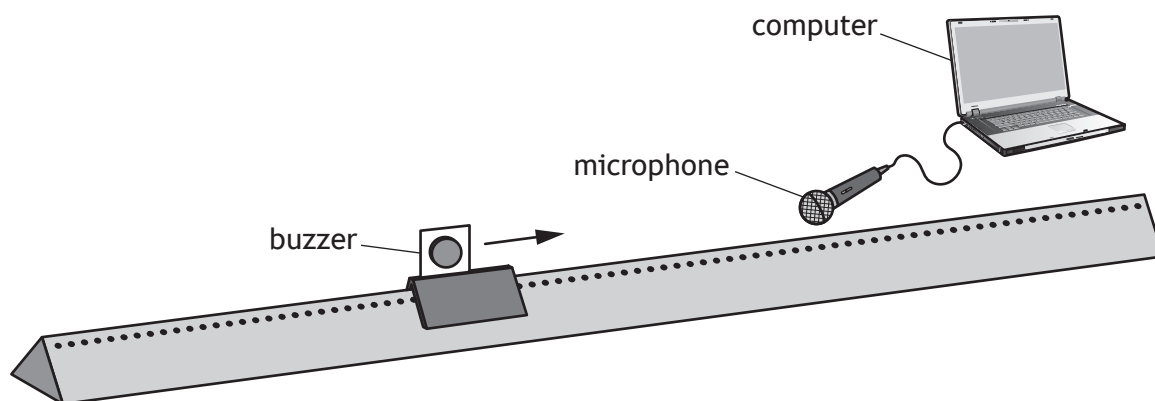

The vehicle is fitted with a buzzer. A microphone is connected to a computer. The vehicle is held stationary and the buzzer is switched on. The buzzer emits sound with a frequency of 845 Hz.

The vehicle now travels at a constant speed towards the microphone. The frequency of sound measured by the computer is 849 Hz.

- (i) Calculate the speed of the vehicle along the linear air track.

Space for working and answer

3



2. (d) (continued)

- (ii) Explain, in terms of wavefronts, why the frequency of the sound detected by the microphone is greater than the frequency of the sound emitted by the buzzer.

You may wish to use a diagram.

1

- (iii) A student standing at the end of the linear air track, near the microphone, states that they did not hear this small change in frequency.

Using the same apparatus, describe one way the Doppler effect could be made more obvious for the student.

1

[Turn over



* X 8 5 7 7 6 0 1 1 1 *

3. An activity at an inflatable park involves a visitor lying on a large air bag. A member of staff jumps down onto the air bag. This causes the visitor to 'fly' through the air and land in a ball pit.

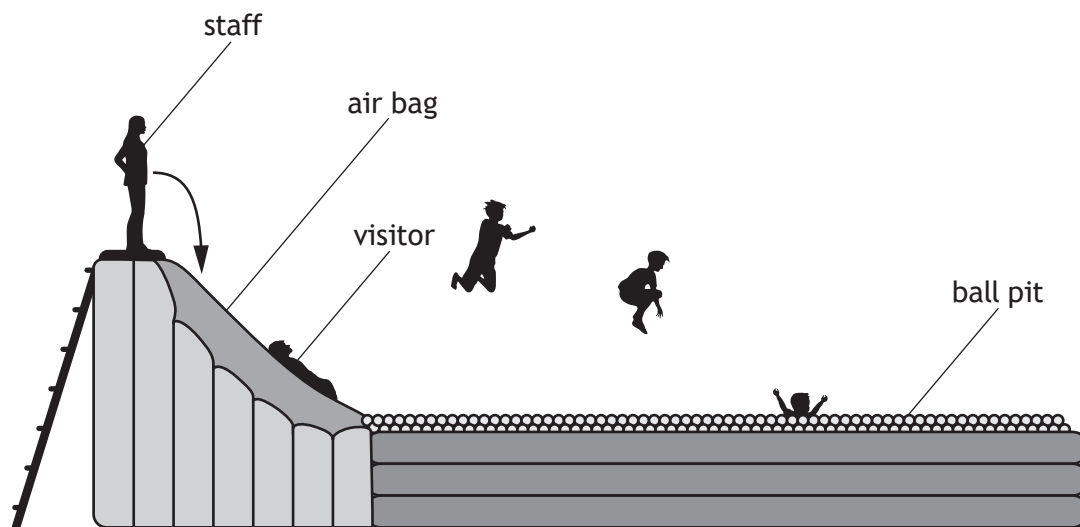

Using your knowledge of physics, comment on the principles of how the activity works.

3



3. (continued)

[Turn over



* X 8 5 7 7 6 0 1 1 3 *

4. The Theory of Special Relativity states that the measurement of time for an observer moving at high speed is changed relative to a stationary observer.

(a) State the name of this effect.

1

(b) A spacecraft is travelling at a constant speed of $2.29 \times 10^8 \text{ m s}^{-1}$ relative to a nearby planet.

A technician on the spacecraft measures a time interval to be 245 s.

Calculate the time interval as measured by an observer on the nearby planet.

3

Space for working and answer



* X 8 5 7 7 6 0 1 1 4 *

4. (continued)

(c) A student makes the following statement regarding special relativity:

‘Train drivers who travel at speeds of 80 m s^{-1} over large distances will have to reset their watches frequently, as they spend so many hours travelling at high speeds.’

State whether the student is correct.

Justify your answer.

2

[Turn over



5. The table contains information about three stars in the Milky Way galaxy.

Star	Surface temperature (K)	Radius (m)	Mass (kg)
star 1	2290	8.14×10^7	1.77×10^{29}
Sun	5800	6.96×10^8	1.99×10^{30}
star 2	210 000	5.57×10^8	5.69×10^{31}

- (a) Compare the surface temperature of star 2 with the surface temperature of star 1 in terms of orders of magnitude.

2

Space for working and answer



5. (continued)

(b) Stars emit radiation with a range of wavelengths.

The graph shows how the energy emitted per second per unit area varies with the wavelength λ of emitted radiation from the Sun.

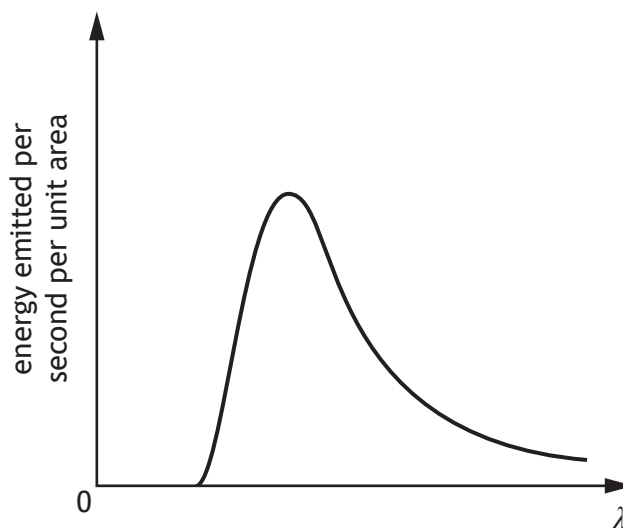

(i) On the graph above, add a line to show how the energy emitted per second per unit area varies with the wavelength of emitted radiation λ from star 2.

2

(An additional graph, if required, can be found on page 51.)

(ii) Explain why star 1 appears more red than the Sun.

1

[Turn over



5. (continued)

- (c) (i) Exoplanets are planets that are outside our Solar System. Star 1 is orbited by a number of exoplanets.

One exoplanet, planet A, has a mean orbital radius of 1.81×10^{11} m and a mass of 6.09×10^{24} kg.

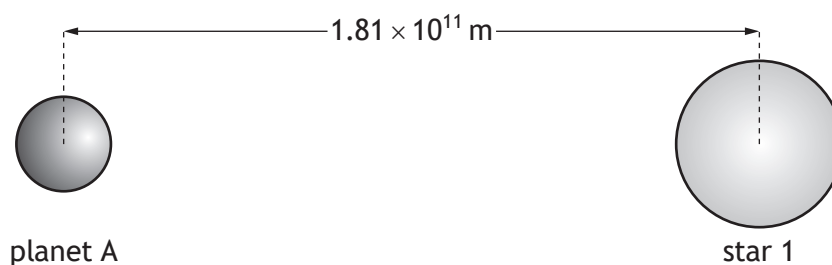

not to scale

The mass of star 1 is 1.77×10^{29} kg.

Calculate the gravitational force between planet A and star 1.

3

Space for working and answer



* X 8 5 7 7 6 0 1 1 8 *

5. (c) (continued)

- (ii) A second exoplanet, planet B, has three times the mass of planet A.
 The mean orbital radius of planet B is double the mean orbital radius of planet A.
 State how the gravitational force of attraction between planet B and star 1 compares to the gravitational force of attraction between planet A and star 1.
 Justify your answer.

3

- (iii) The exoplanets orbiting star 1 were discovered using the ‘transit method’. The brightness of the light from the star is recorded. A dip in brightness is recorded during the time it takes the exoplanet to pass between the star and an observer.

The table gives information about the exoplanets, planet A and planet B.

Exoplanet	Radius of exoplanet (m)	Mean orbital radius (m)	Orbital period (s)
planet A	7.1×10^6	1.81×10^{11}	1.4×10^8
planet B	5.0×10^6	3.62×10^{11}	4.0×10^8

The graph shows how the brightness varies with time as planet B passes between the star and the observer.

Add a line to the graph to show how the brightness varies with time as planet A passes between the star and the observer.

2

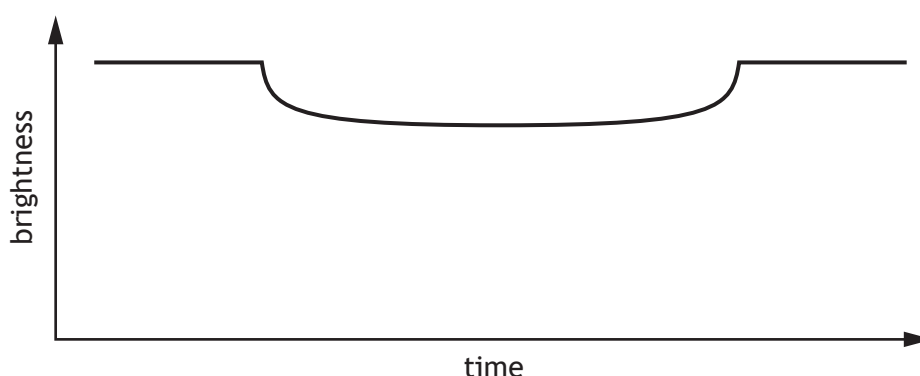

(An additional graph, if required, can be found on page 51.)



6. (a) The following statement represents a nuclear decay in which an alpha particle is emitted.

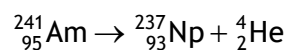

- (i) Explain why energy is released in this decay.

1

- (ii) The mass of the particles involved in this decay are shown in the table.

Particle	Mass (kg)
${}_{95}^{241}\text{Am}$	4.0028×10^{-25}
${}_{93}^{237}\text{Np}$	3.9363×10^{-25}
${}_2^4\text{He}$	6.6447×10^{-27}

Determine the energy released in this decay.

4

Space for working and answer



6. (continued)

- (b) Carbon-14 undergoes nuclear decay by releasing a beta particle ${}_{-1}^0e$.
The following statement represents this decay.

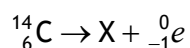

- (i) Identify the element represented by X. 1

- (ii) An explanation for beta decay is that a neutron decays into a proton and an electron. The electron is emitted as a beta particle.

However, studies of beta decay show that the mass-energy equivalence of carbon-14 is greater than the total mass-energy equivalence of element X and the beta particle.

State the conclusion that particle physicists have drawn from this evidence about what happens during beta decay. 1

[Turn over



6. (continued)

- (c) Quarks are fundamental particles that do not exist by themselves but make up other particles called hadrons.

There are six types of quark: up, down, charm, strange, top, and bottom.

- (i) Explain what is meant by the term *fundamental particle*.

1

- (ii) Hadrons can be further classified according to the number of quarks they contain.

State the type of particles that contain three quarks.

1



* X 8 5 7 7 6 0 1 2 2 *

6. (c) (continued)

(iii) Scientists have discovered a type of particle called pentaquarks.

Pentaquarks contain 4 quarks and 1 antiquark.

Recently scientists at CERN reported the discovery of a pentaquark containing 1 up, 1 down, 1 strange, 1 charm, and 1 anticharm quark.

The table contains information about the charge of some of the quarks that make up this pentaquark.

Type of quark	Charge
Up	$+\frac{2}{3}e$
Down	$-\frac{1}{3}e$
Charm	$+\frac{2}{3}e$

The overall charge on the pentaquark is 0.

Determine the charge of a strange quark.

Space for working and answer

2

[Turn over



7. A student sets up an experiment, in a darkened room, to investigate the relationship between irradiance I and distance d from a point source of light. The apparatus used is shown.

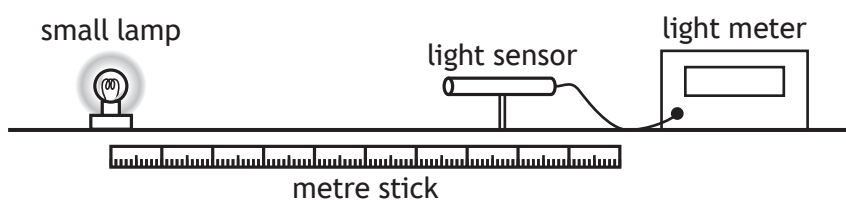

The distance between the lamp and the light sensor is measured with a metre stick. The irradiance is measured with a light meter.

The results obtained are shown in the table.

d (m)	0.200	0.400	0.600	0.800
I (W m^{-2})	198.4	49.6	22.0	12.4

- (a) State what is meant by the term *irradiance*.

1

- (b) Use all the data to establish the relationship between irradiance I and distance d .

3

Space for working and answer



7. (continued)

- (c) Other than repeating each measurement and calculating the mean, suggest **two** improvements that could be made to the student's experimental procedure.

2

- (d) A second student carries out the experiment using a laser instead of a lamp.

- (i) The laser beam is initially shone onto the light sensor from a distance of 0.20 m.

The beam produces a uniformly lit circle of diameter 1.00×10^{-3} m on the light sensor.

The irradiance of the circle of light is $1.51 \times 10^3 \text{ W m}^{-2}$.

Determine the power of the laser beam.

4

Space for working and answer

[Turn over



* X 8 5 7 7 6 0 1 2 5 *

7. (d) (continued)

- (ii) The student moves the laser to a distance of 0.40 m from the sensor. The reading on the light meter does not change. Suggest why the reading does not change.

1



* X 8 5 7 7 6 0 1 2 6 *

[Turn over for next question

DO NOT WRITE ON THIS PAGE



* X 8 5 7 7 6 0 1 2 7 *

8. Radiation of frequency 1.30×10^{15} Hz from an ultraviolet lamp is incident on a clean metal plate.

This causes electrons to be emitted from the surface of the metal plate.

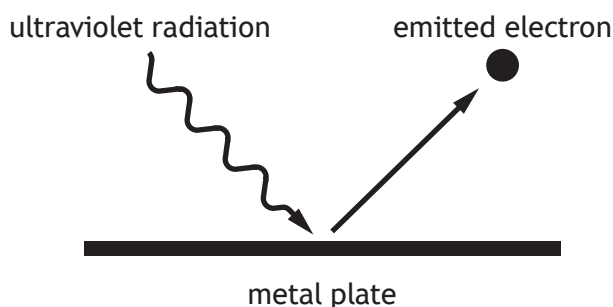

This is an example of the photoelectric effect.

- (a) Explain why the photoelectric effect provides evidence supporting the particle model of light.

1

- (b) The work function of the metal plate is 5.89×10^{-19} J.

(i) State what is meant by the term *work function*.

1

- (ii) Calculate the maximum kinetic energy of an electron emitted from the surface of the metal plate.

3

Space for working and answer



* X 8 5 7 7 6 0 1 2 8 *

8. (b) (continued)

(iii) The ultraviolet lamp is now moved further away from the metal plate. This reduces the irradiance of the ultraviolet radiation incident on the metal plate.

State what effect, if any, this has on the maximum kinetic energy of an electron emitted from the surface of the metal plate.

You must justify your answer.

2

[Turn over



9. A student studies the effect of different wavelengths of light on a sample of chlorophyll.
- Chlorophyll is a green pigment, present in all green plants, which is responsible for the absorption of light to provide energy for photosynthesis.
- The student sets up the apparatus shown, using a grating with 1000 lines per millimetre to produce an interference pattern.
- The interference pattern consists of a central white maximum and a series of spectra on either side of the central maximum.
- The student uses the first order spectrum to study the absorption of different wavelengths of light by chlorophyll. The percentage absorption of the different wavelengths of light is measured using a spectrophotometer.

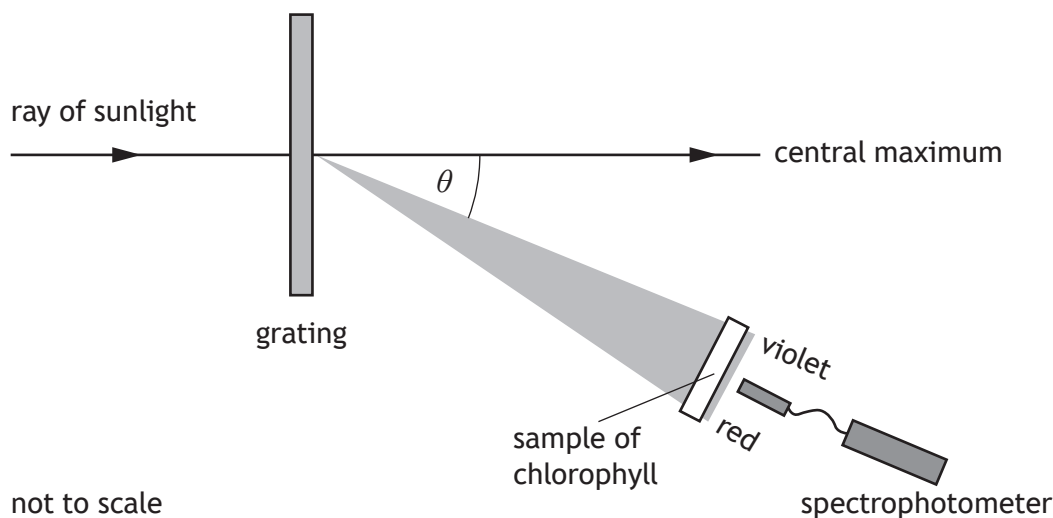

- (a) Explain why the central maximum is white.

2



9. (continued)

- (b) The wavelength of light at the violet end of the first order spectrum is 412 nm. Calculate the angle θ between the central maximum and the violet end of the spectrum.

Space for working and answer

3

[Turn over



* X 8 5 7 7 6 0 1 3 1 *

9. (continued)

- (c) The graph shows how the percentage of light absorbed by the chlorophyll varies with wavelength of light.

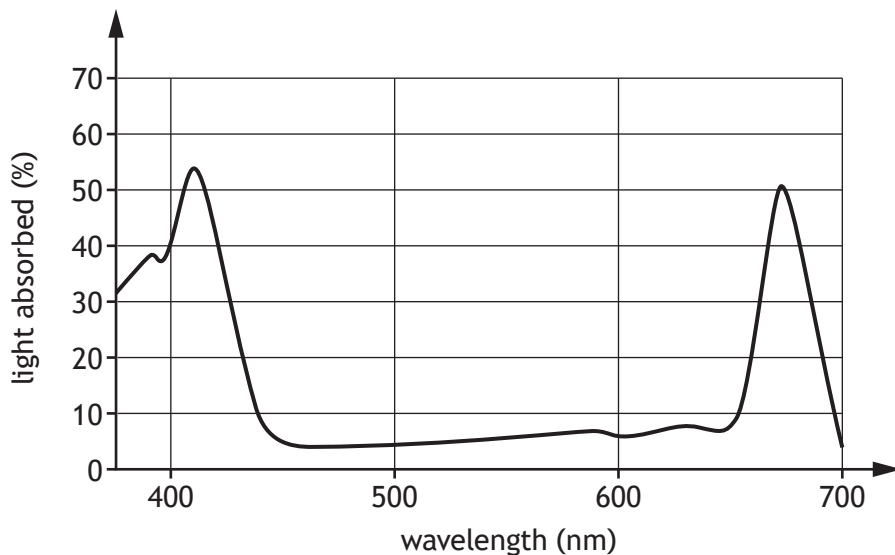

Using information from the graph, suggest why the light passing through the chlorophyll sample appears green.

2



9. (continued)

- (d) Another student suggests using a grating with 250 lines per millimetre. The student claims that this will allow them to more accurately determine which wavelengths of light are absorbed by the chlorophyll.

Explain why the student's suggestion is incorrect.

2

[Turn over



* X 8 5 7 7 6 0 1 3 3 *

10. Light from the Sun is a continuous spectrum containing dark lines as shown.

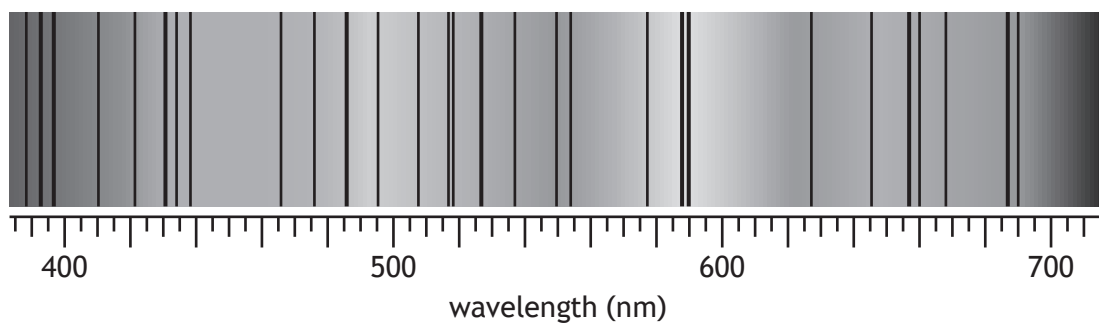

(a) Explain how these dark lines in the spectrum of sunlight are produced.

2

(b) One of the dark lines corresponds to the blue-green line in the hydrogen spectrum.

(i) State the wavelength of this blue-green spectral line.

1

(ii) Calculate the frequency of this spectral line.

3

Space for working and answer



10. (b) (continued)

MARKS DO NOT WRITE IN THIS MARGIN

(iii) Some of the energy levels of the hydrogen atom are shown.

E_4	_____	$-0.871 \times 10^{-19} \text{ J}$
E_3	_____	$-1.36 \times 10^{-19} \text{ J}$
E_2	_____	$-2.42 \times 10^{-19} \text{ J}$
E_1	_____	$-5.45 \times 10^{-19} \text{ J}$
E_0	_____	$-21.8 \times 10^{-19} \text{ J}$

The dark line corresponding to the blue-green line in the hydrogen spectrum is produced due to an electron transition between E_1 and one of the other energy levels.

(A) Calculate the energy of the photon involved in this transition. 3
Space for working and answer

(B) Identify the electron transition that produces this dark line. 1

[Turn over



10. (continued)

- (c) One of the other dark lines in the spectrum of the Sun corresponds to a wavelength of 656 nm in the hydrogen spectrum. In the spectrum of light from a distant galaxy, the corresponding dark line is observed at 672 nm.

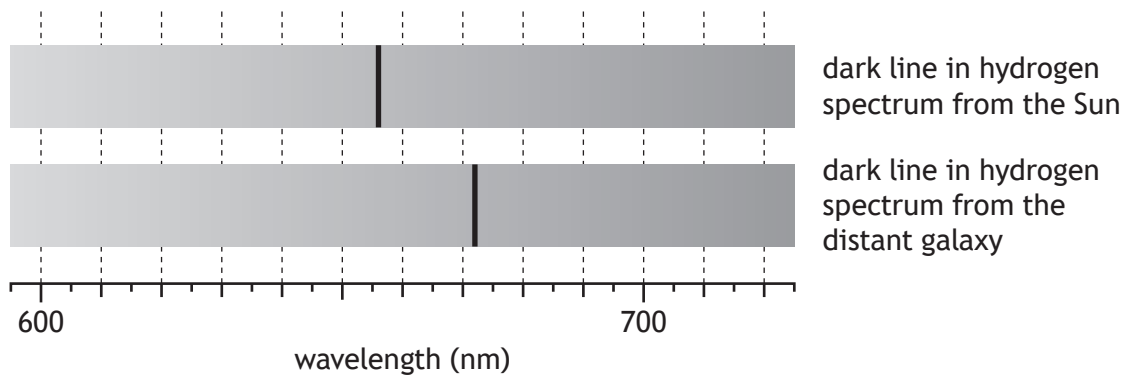

- (i) Determine the recessional velocity of this galaxy.

Space for working and answer

5



10. (c) (continued)

- (ii) A second galaxy produces a spectrum where the corresponding dark line is observed in a different position. This galaxy has a recessional velocity of $4.88 \times 10^6 \text{ m s}^{-1}$.

On the diagram below, add a line to show where this dark line would be observed on the spectrum of the second galaxy.

A numerical value is not required.

(An additional diagram, if required, can be found on *page 52*.)

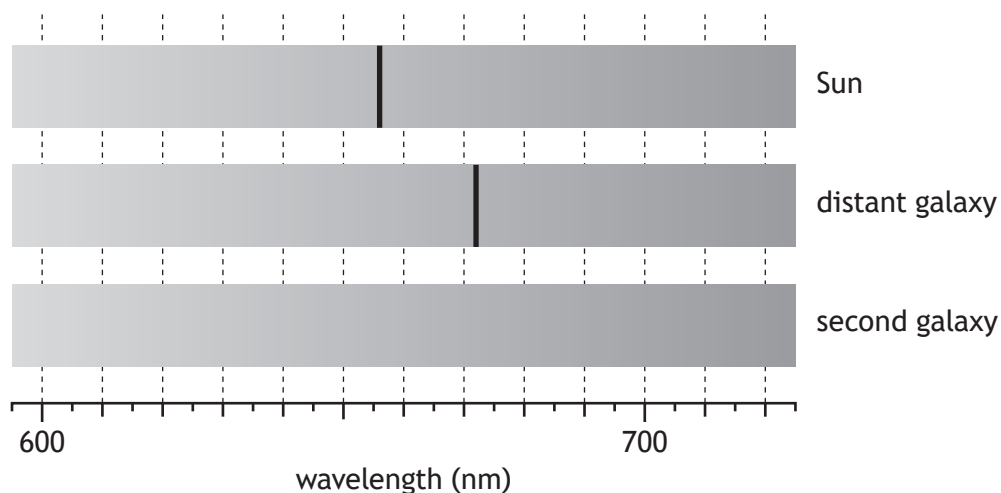

1

- (d) Through observation of distant galaxies, it has been observed that the Universe is expanding at an accelerating rate.

State what physicists think is responsible for this accelerating rate of expansion.

1

[Turn over



11. A student sets up a circuit using an AC supply of negligible internal resistance as shown.

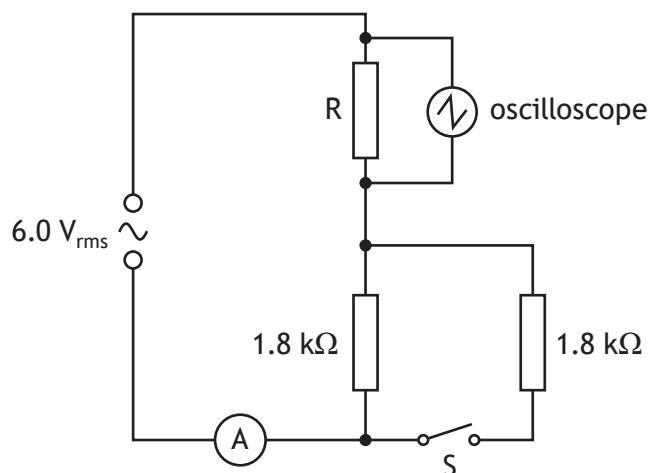

- (a) Switch S is open.
 The ammeter displays the rms current. The reading on the ammeter is 2.0 mA.
 Determine the resistance of resistor R.
Space for working and answer

4



11. (continued)

(b) The oscilloscope screen is shown.

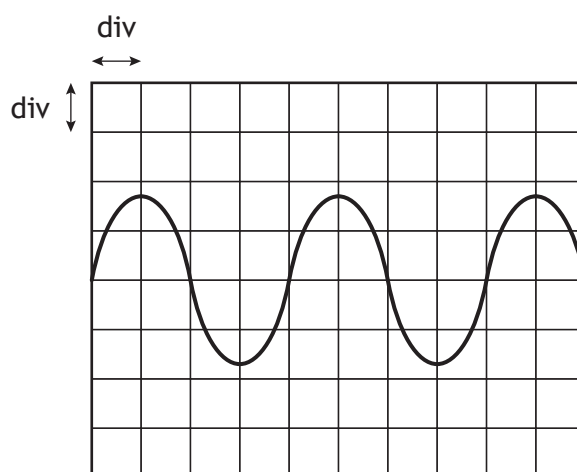

The timebase setting on the oscilloscope is 5.0 ms/div.

Show that the frequency of the AC supply is 50 Hz.

Space for working and answer

3

(c) Switch S is now closed. The settings on the AC supply and the oscilloscope are unchanged.

State whether the amplitude of the trace on the oscilloscope increases, stays the same, or decreases.

You must justify your answer.

3

[Turn over



[BLANK PAGE]

DO NOT WRITE ON THIS PAGE



* X 8 5 7 7 6 0 1 4 0 *

12. (a) A student sets up a circuit to investigate the charging of a capacitor.

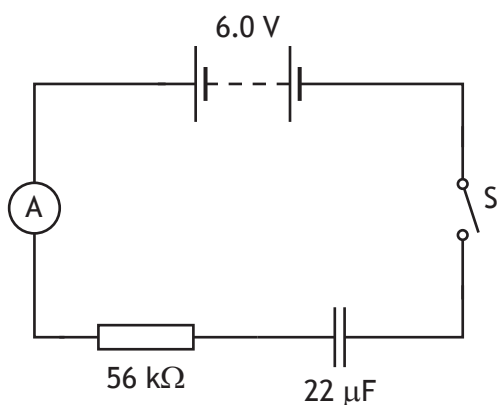

The capacitor is initially uncharged. The student closes the switch and the capacitor takes 6.2 s to fully charge.

On the axes below, sketch a graph of current I against time t for the capacitor to fully charge.

Numerical values are required on both axes.

3

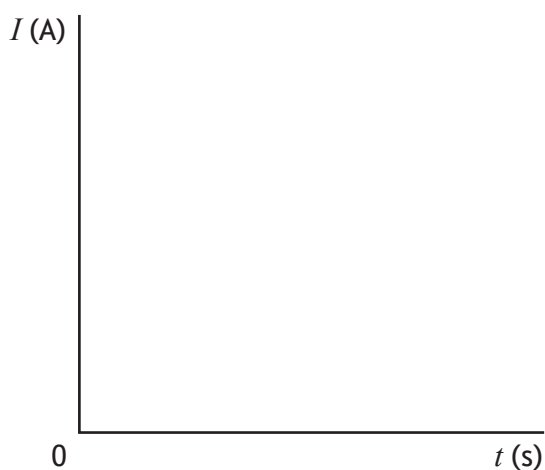

(An additional graph, if required, can be found on page 52.)

[Turn over



12. (continued)

MARKS DO NOT WRITE IN THIS MARGIN

- (b) In a second experiment, the student sets up a circuit to determine the capacitance C of a different capacitor.

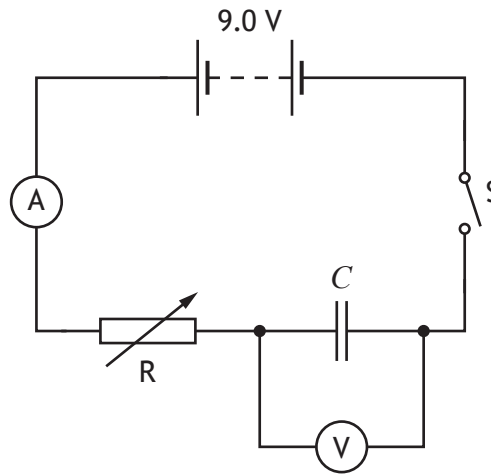

The resistance of the variable resistor can be adjusted to maintain a constant charging current.

Initially, the capacitor is uncharged.

Switch S is closed and the capacitor begins to charge.

- (i) State whether the student should be increasing or decreasing the resistance of the variable resistor R to maintain a constant charging current.

Justify your answer.

2

- (ii) During the experiment, there is a constant charging current of $15 \mu\text{A}$. The capacitor takes 28 s to fully charge.

Calculate the charge stored on the capacitor when it is fully charged.

Space for working and answer

3



12. (b) (continued)

(iii) Calculate the capacitance C of the capacitor.

Space for working and answer

3

[Turn over



* X 8 5 7 7 6 0 1 4 3 *

13. The use of analogies from everyday life can help improve the understanding of physics concepts.

A student describes how an office building with two floors can be used as an analogy for band theory in solid materials.

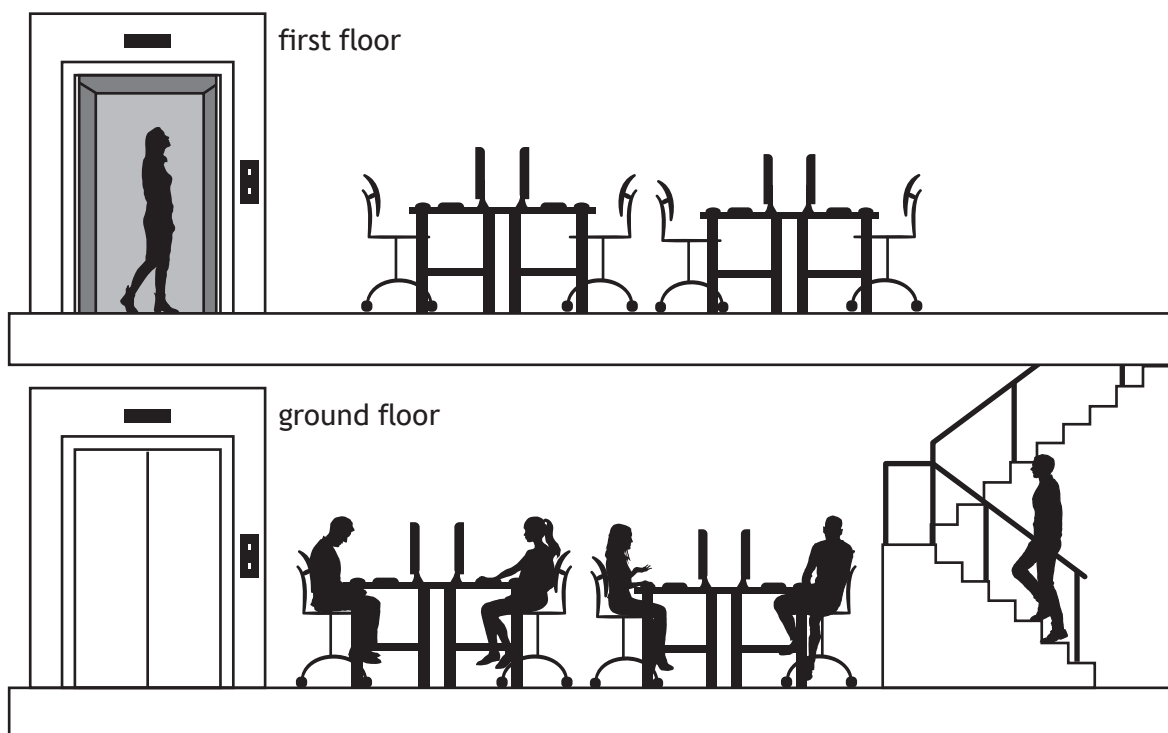

The student states:

‘All the desks on the ground floor of the office must be occupied before workers can occupy a desk on the first floor. This represents an insulator.

‘The first floor is only unlocked when the ground floor is full.

‘When the whole office is full, no worker can change the desk that they are working at. This represents no current.’

Using your knowledge of physics, comment on this analogy.

3



* X 8 5 7 7 6 0 1 4 4 *

13. (continued)

[Turn over



* X 8 5 7 7 6 0 1 4 5 *

14. Young's modulus E of a material is a measure of its stiffness.
A student sets up an experiment to determine Young's modulus of a copper wire.

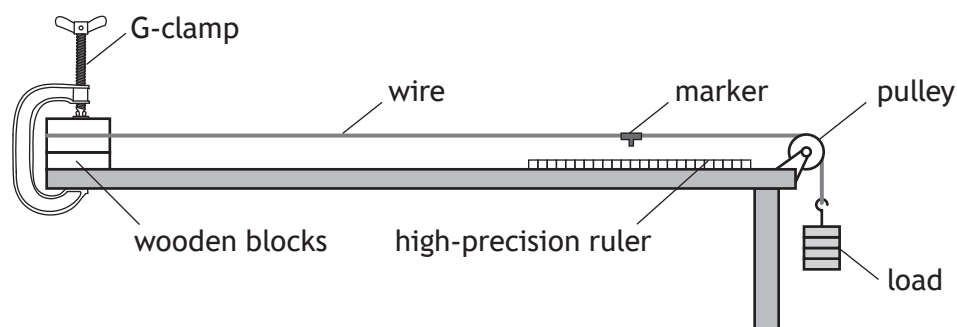

The student applies a force to the wire, which causes the wire to stretch.
The extension of the wire is the difference between its new length and its original length.
The student varies the force F applied to the wire and measures the corresponding extension e of the wire.
The student records the following information.

F (N)	e ($\times 10^{-3}$ m)
2.0	0.5
3.9	1.0
5.9	1.6
7.8	2.1
9.8	2.7
10.8	3.2

- (a) (i) Using the square-ruled paper on *page 48*, draw a graph of F against e . 3
(The table of results is also shown on *page 49*, opposite the square-ruled paper.)
- (ii) Calculate the gradient of the line of best fit on your graph. 2
Space for working and answer



14. (a) (continued)

(iii) Young's modulus can be determined using the relationship

$$F = \frac{EA}{L}e$$

where: E is Young's modulus in Pa

F is the force applied to the wire by the load in N

L is the original length of the wire in m

A is the cross-sectional area of the wire in m^2

e is the extension of the wire in m.

The original length of the copper wire is 1.500 m and the cross-sectional area is $5.9 \times 10^{-8} \text{ m}^2$.

Using the gradient of your line of best fit, determine Young's modulus of the copper wire.

2

Space for working and answer

(b) The student plots a graph of the data and concludes that there is a systematic uncertainty associated with this data.

Suggest why the student reached this conclusion.

1

[END OF QUESTION PAPER]



* X 8 5 7 7 6 0 1 4 7 *

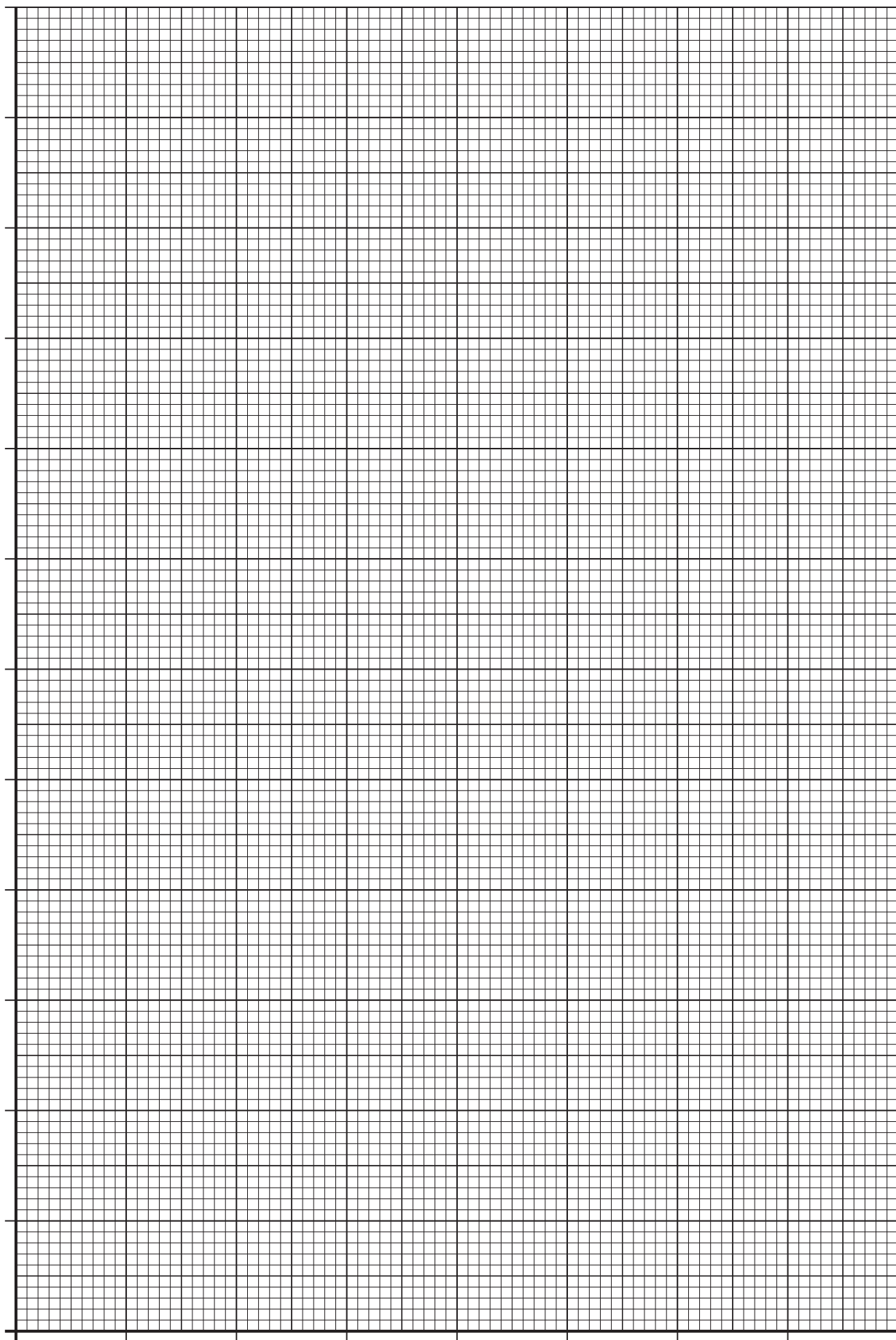

* X 8 5 7 7 6 0 1 4 8 *

ADDITIONAL SPACE FOR ANSWERS AND ROUGH WORK

Additional table for use with question 14 (a) (i)

F (N)	e ($\times 10^{-3}$ m)
2.0	0.5
3.9	1.0
5.9	1.6
7.8	2.1
9.8	2.7
10.8	3.2



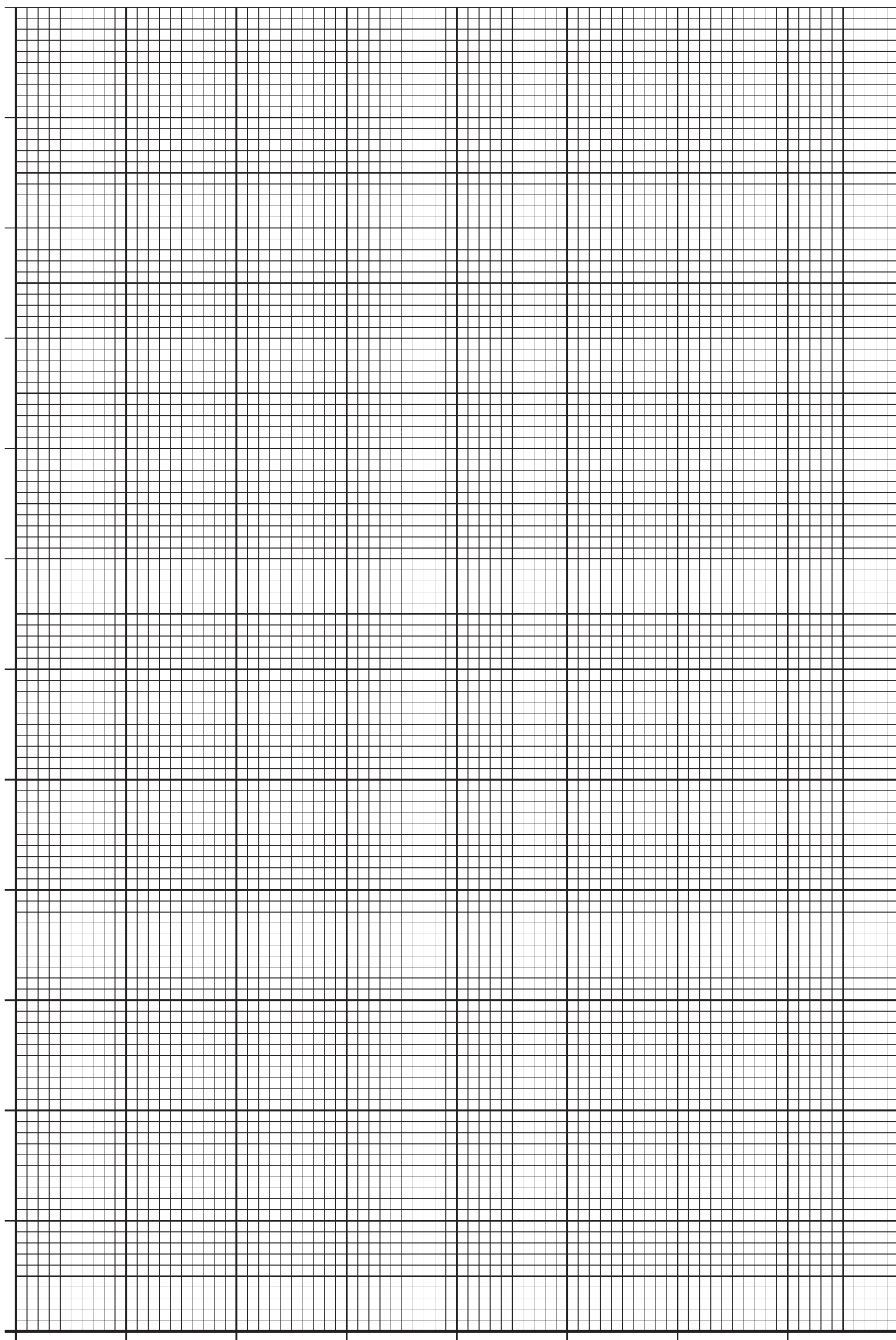

* X 8 5 7 7 6 0 1 5 0 *

ADDITIONAL SPACE FOR ANSWERS AND ROUGH WORK

Additional graph for use with question 5 (b) (i)

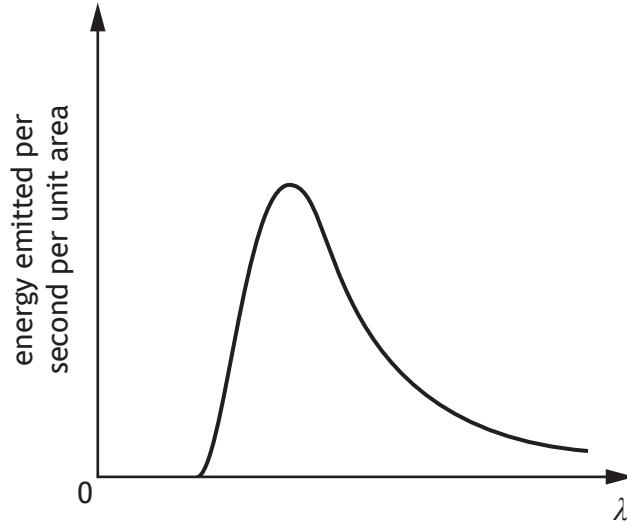

Additional graph for use with question 5 (c) (iii)

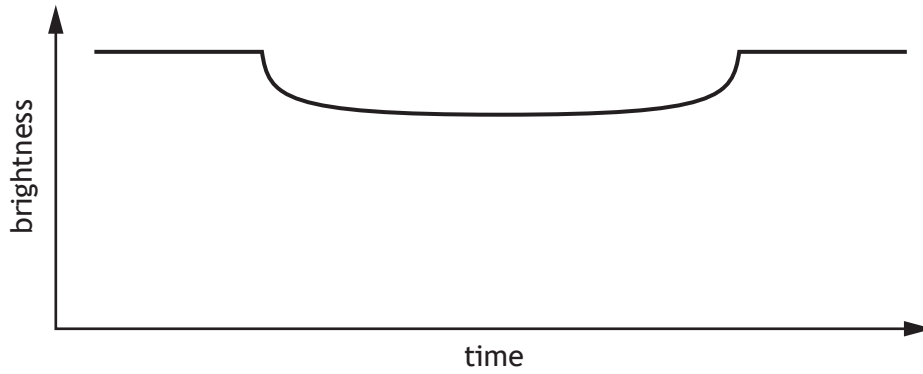

ADDITIONAL SPACE FOR ANSWERS AND ROUGH WORK

Additional diagram for use with question 10 (c) (ii)

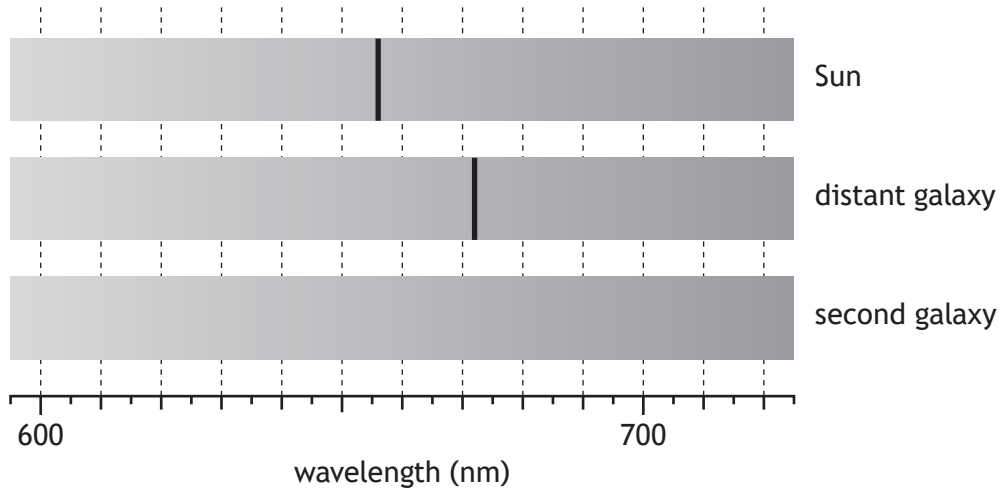

Additional graph for use with question 12 (a)

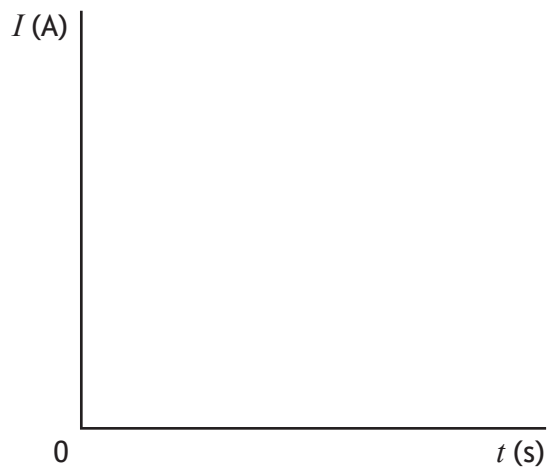

MARKS DO NOT
WRITE IN
THIS
MARGIN

ADDITIONAL SPACE FOR ANSWERS AND ROUGH WORK



* X 8 5 7 7 6 0 1 5 3 *

MARKS DO NOT
WRITE IN
THIS
MARGIN

ADDITIONAL SPACE FOR ANSWERS AND ROUGH WORK



* X 8 5 7 7 6 0 1 5 4 *

[BLANK PAGE]

DO NOT WRITE ON THIS PAGE



* X 8 5 7 7 6 0 1 5 5 *

[BLANK PAGE]

DO NOT WRITE ON THIS PAGE



* X 8 5 7 7 6 0 1 5 6 *